

SG

BLACKZON



BLACKZON
MYTE
RACER

BLACKZON
MYTE
DRIFTER

Startup Guide



548100-006-SG

THANK YOU

Thank you for selecting this Blackzon RC product! HAVE FUN! But please read this first !!

We know you will have great fun with your model, but to get the best from your purchase please read this information BEFORE you operate the model.

SAFETY PRECAUTIONS

This product is an authentic radio controlled vehicle (RC vehicle) and it is not a toy. Read and understand this instruction manual thoroughly before running the model. If you are not familiar with RC vehicles, we recommend that you ask someone familiar with RC vehicles for advice.

Never connect the rechargeable drive battery in the reverse polarity or disassemble the battery. If the drive battery is used in the wrong way, high current can be generated and it is very dangerous.

Never run RC models near people or animals, or on public streets or highways. This could cause serious accidents, personal injuries, and/or property damage.

Make sure the mains power socket when using a charger is readily accessible and never left plugged in when not in use.

If you are using Rechargeable AA's for the Transmitter please make sure you also purchase a suitable charger for this battery type.

GLOSSARY

Below are some common terms used in this manual.

Transmitter	Also called the Radio or Controller.
Receiver	The unit inside the car that receives the signal from the transmitter.
ESC (Electronic Speed Control)	Controls the motor's power and speed.
Servo	The small motor that turns the front wheels for steering.
LiPo Battery	A rechargeable "Lithium Polymer" battery used to power the model.
Trim	A fine-adjustment control that centers steering or throttle.
Dual Rate (D/R)	Adjusts how far the steering can turn left or right.
Binding / Pairing	Creating a communication link between the transmitter and receiver.
Neutral Position	The middle position of the throttle or steering where no movement occurs.

ABOUT US

BlackZon is dedicated to creating fun, durable, and affordable RC vehicles that anyone can enjoy — whether you're brand new to radio-controlled cars or already an experienced hobbyist. Our models are designed to be easy to use, easy to maintain, and ready for adventure straight out of the box.

We are part of the HPI Racing family, bringing together years of RC experience, product development, and support to deliver a great driving experience at every level.

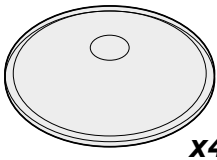
COMPONENTS**x4****Tip**

You can use the provided obstacle markers (x4) to make a course to practice driving

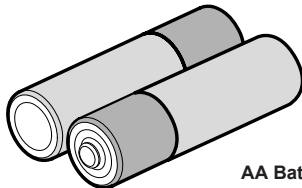
EQUIPMENT NEEDED**x2**

AA Batteries for Transmitter

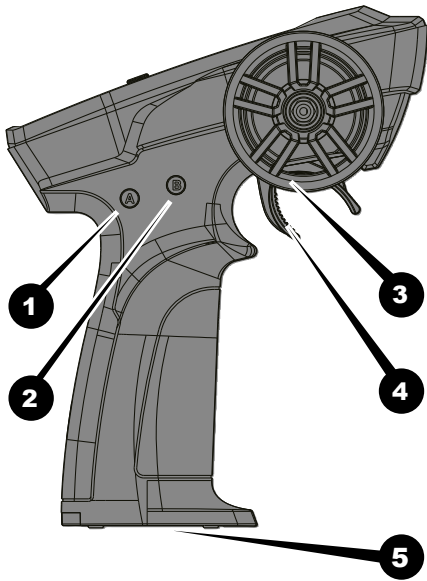
TRANSMITTER INFORMATION

1. Button A: Gyroscope Settings
2. Button B: Car Lights
3. Steering Wheel
4. Throttle Trigger
5. Battery Compartment

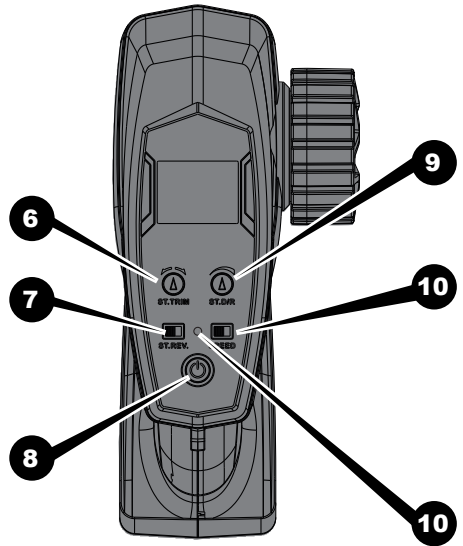

6. Steering Trim
7. Steering Direction Reverse
8. ON/OFF Power Switch
9. Steering D/R
10. Throttle Reverse
11. Indicator LED

1 GETTING STARTED

Battery Information



Caution

Failure to follow the instructions below could result in damage to the product, personal injury, damage to property, and possibly fire.

ONLY USE THE INCLUDED CHARGER TO CHARGE THE BATTERY PACK.

Failure to use a proper charger may result in damage to the battery and possible fire.

LiPo batteries should always be charged in an open area away from flammable materials to reduce the chance of fire and property damage.

DO NOT LEAVE THE BATTERY PACK UNATTENDED WHILST CHARGING.

When charging the battery you should remain in constant observation to monitor the charging process and react to potential problems that could occur.

THE BATTERY SHOULD NEVER BE CHARGED INSIDE THE R/C VEHICLE OR INSIDE A FULL-SIZE VEHICLE.

It is recommended to charge and store the battery in a fireproof LiPo bag to reduce the risk of short circuit and property damage due to fire.

DO NOT USE DAMAGED OR LEAKING BATTERIES.

LiPo batteries should always be handled with care to prevent them from being punctured, dented, scraped or otherwise damaged.

If the battery begins to balloon or swell at any time, quickly and safely disconnect the battery and place it in a safe area away from flammable materials and observe it for at least 15 minutes.

Continuing to charge or discharge a battery that has begun to balloon or swell could result in a fire.

A battery that has ballooned or swollen should be discarded in a safe manner according to your local disposal regulations.

STORE THE BATTERY AT ROOM TEMPERATURE AND APPROXIMATELY 1/2 CHARGE.

Avoid storing the battery in environments that can reach high temperatures, like an automobile in direct sunlight. Storing the battery at minimum or maximum voltage will decrease the usable lifespan of the battery and may lead to cell damage, deterioration and swelling.

Do not allow the battery to come in contact with water or liquids. Submersing the battery could cause dangerous short-circuits and damage the battery.

Never place LiPo batteries in your pocket or any other area where they could come into contact with objects that could cause shorting, puncturing or other forms of damage.

1 GETTING STARTED

1.1 Install Transmitter Batteries



1. Open the battery holding tray to expose the empty battery slots.
2. Insert 2 AA batteries into the marked spaces.
3. Please note the correct direction of the batteries

Incorrect battery insertion could damage the transmitter.

1.2 Charge Car Battery

1. Connect the Type-C USB charger to the charging port located at the bottom of the vehicle.
2. Then, insert the USB charger into the USB charging port on the wall adapter.
3. During charging, the red LED on the PCB will be illuminated.
4. Once the battery is fully charged, the red LED will turn off.
5. The typical charging time is approximately 50 to 60 minutes.

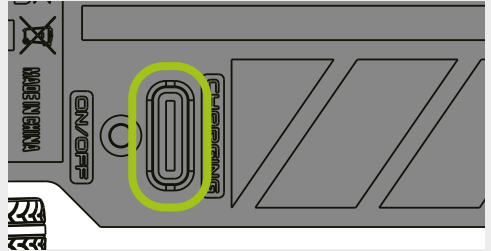



6. When storing the car for an extended period, the battery should be kept above 70% charge to maximize its lifespan.
7. Charge the battery once every 1-2 months to prevent damage.
8. It is recommended to fully charge the battery before use.

Do not use a wet USB charger.

Charge in a clean, dry, well-ventilated area, away from heat and moisture.

Never leave the vehicle unattended while charging.

LED Status

-  Solid Red: Charging
-  LED off: Fully Charged

2 SWITCHING ON

To get running,, the first step is to bind the receiver to the car.

Binding (also called pairing) is the process of creating a secure connection between the transmitter and the ESC/Receiver, allowing the model to respond only to that specific transmitter. In most cases, the binding process will happen automatically when both the transmitter and the ESC/Receiver are switched ON and within range.



Caution

Turn on transmitter first and then turn on receiver.

2.1 Switch on Transmitter

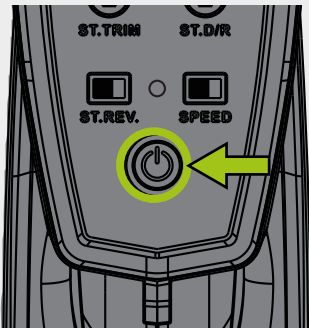

Press the power switch to turn on. The LED will flash rapidly in red.

2.2 Switch on Receiver (Car)

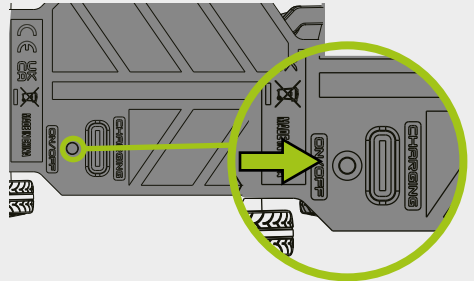

Press and hold for 2-3 sec. to switch on The vehicle lights will flash rapidly, the turn solid once binding is complete.

2.3 Binding/Pairing Successful

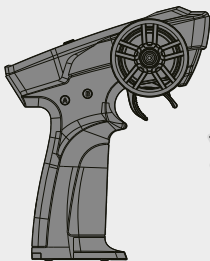

When the Transmitter LED is solid green and the car lights are on solid, then binding is complete - your car is ready to drive!



Attention

The car and transmitter should bind automatically so that the car operates using the transmitter after switching on.

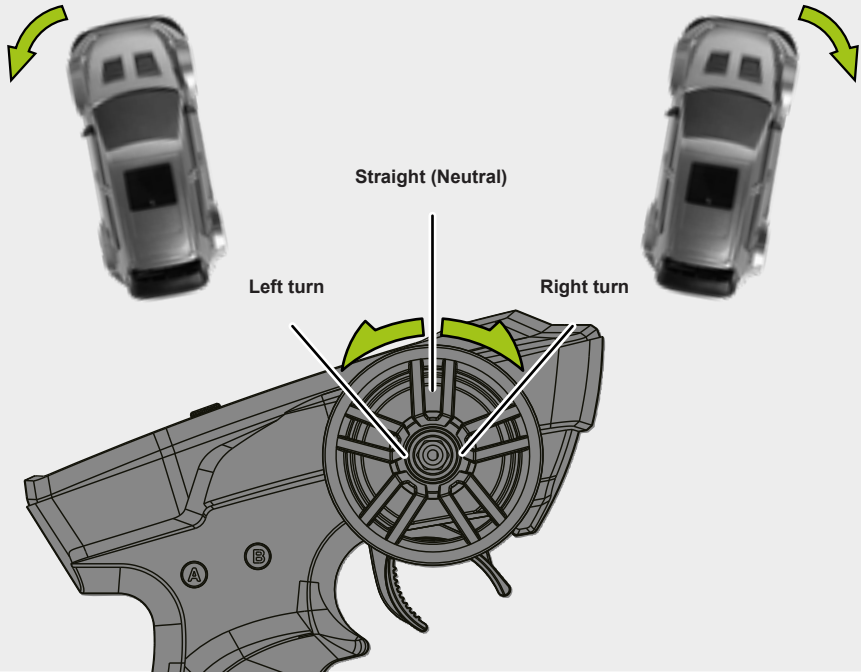
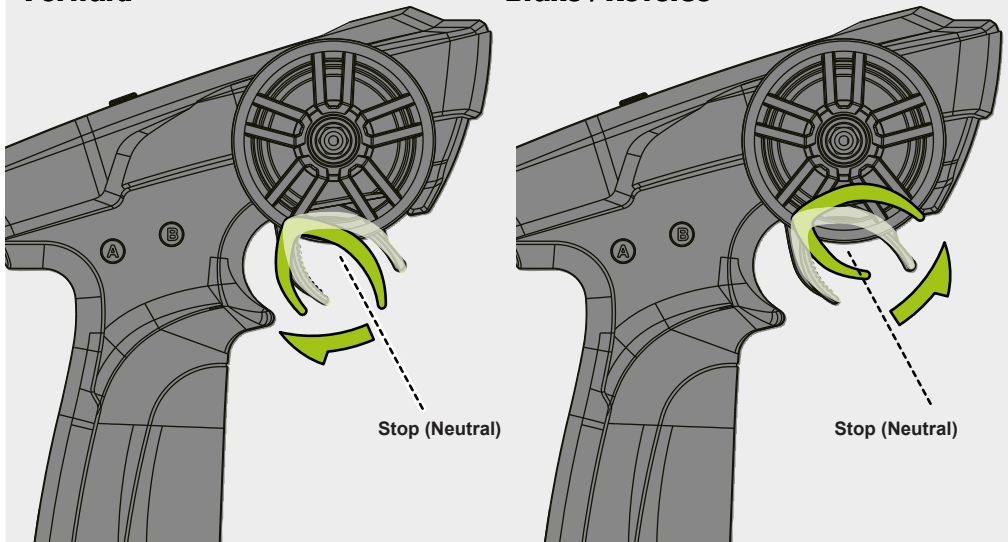
3 USING THE TRANSMITTER**3.1 Steering****3.2 Acceleration/Braking****Forward****Brake / Reverse**

3 USING THE TRANSMITTER

3-3 Function Button A

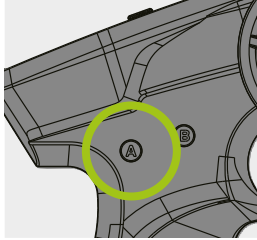

Use this button for Gyroscope Settings - see Section 7-5

3-4 Function Button B

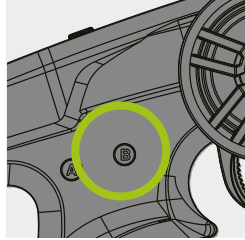

Car Lights On/Off
Press and hold the button B for 2-3 seconds to turn the car lights on or off.

4 MAINTENANCE AFTER DRIVING

After running it is necessary to perform routine maintenance. Failure to do this can result in increased wear and damage to the motors and chassis.

Use Tweezers to remove the drive shaft and tire of debris.

After each run, clean the chassis and check all moving parts for any damage or wear.

If any parts are broken or worn out, repair or replace them before your next run.

Use the schedule below as a general maintenance guide.

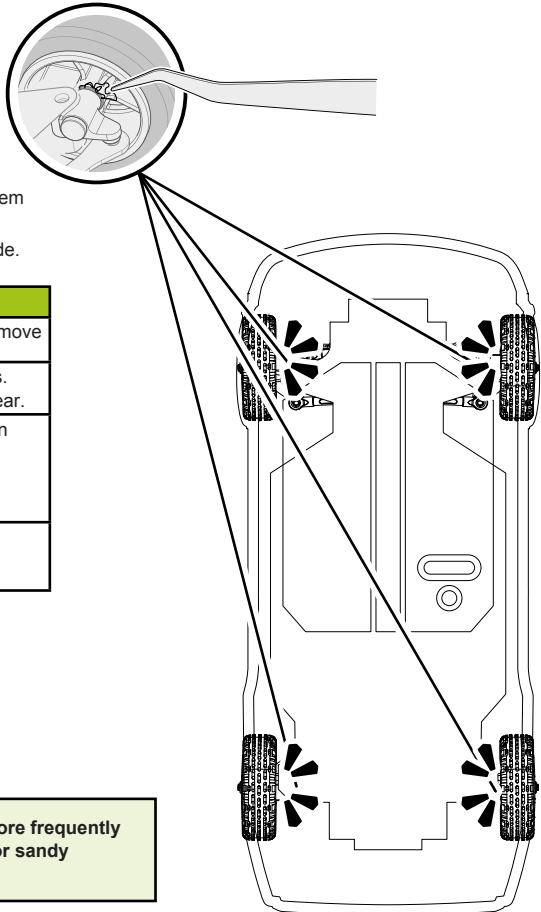

Interval	Maintenance Item
After every run	Clean chassis and suspension, remove dirt and debris.
Every 10 runs	Check wheels, tyres, and bearings. Inspect gears and drivetrain for wear.
Every 20 runs	Inspect and clean motor and pinion gears. Check differential and shock absorbers. Lubricate moving parts.
Occasionally	Check radio system, wiring, and connectors. Replace batteries if needed.



Tip

Perform maintenance more frequently if driving in dusty, wet, or sandy conditions.

5 FAIL SAFE SYSTEM

This car has a built-in fail safe system that will stop the car if the radio glitches, either because of interference or if the car goes out of range.

The fail safe system has been setup at the factory, but you should become familiar with the function of the fail safe and check the operation before running.

To check the failsafe:

1. Set the car so that the wheels can turn, but it will not move, either by putting on a stand or turning upside down.
2. Turn on the transmitter, and then the car.
3. Move the throttle trigger to turn the car wheels (accelerate).
4. Whilst the car is running, turn off the transmitter.

If the failsafe is working, the car's wheels should stop turning.

6 CHECK RADIO RANGE

To check the radio range safely:

Ask a friend to hold the model securely while you walk to the farthest distance you plan to operate it. Use the transmitter controls to confirm that the model responds correctly.

If you notice any delay, loss of signal, or unusual behavior, do not operate the model until the issue is resolved.

Always switch on the transmitter first, then the model.

If the model is powered on before the transmitter, you may lose control.

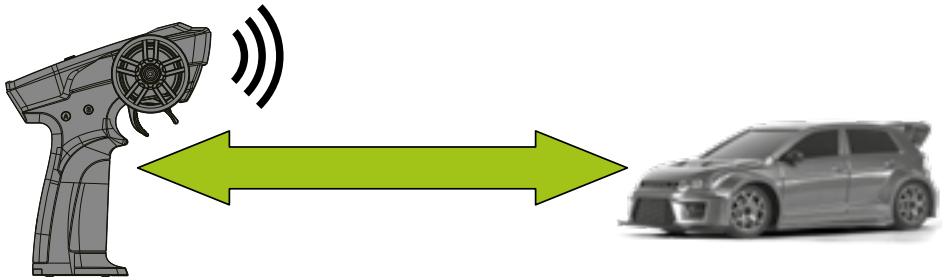

Cautions

2.4GHz radio frequency only functions by line of sight, if you drive behind a solid object or around a corner and lose sight of the vehicle you may lose control of the RC car.

7 BASIC TROUBLESHOOTING

Your car should be ready to go out the box, but some functions can be fine-tuned or changed to customise handling and performance.

7-1 Steering Trim Setup (ST TRIM)

The wheels should be central so that the car goes in a straight line if no steering is applied. The steering trim allows the tires to be set in a completely centered position.

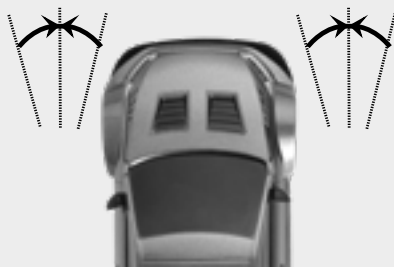
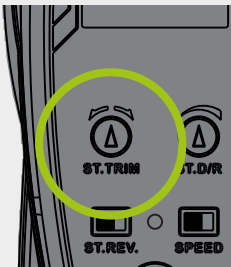

7-2 Steering Reverse Switch (ST REV)



If the vehicle turns right when you steer left and turns left when you steer right, flip the "Steering Reverse" switch.

7-3 Steering Dual Rate (ST D/R)

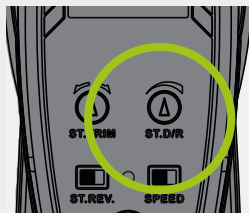

Steering Dual Rate:

The Steering Dual Rate (ST D/R) knob adjusts how far the front wheels turn when you steer.

1. Turn the knob clockwise to increase steering throw (tighter turning).
2. Turn the knob anticlockwise to reduce steering throw (smoother control).

For best handling, it's recommended to keep the steering throw within 75%.

This helps avoid excessive turning that can cause the front tyres to rub against the body shell and ensures smoother, more precise steering control.



Tip

Adjust the steering dual rate while driving to fine-tune handling — increase it for tight corners or decrease it for better stability at high speeds.

7-4 Speed Switch

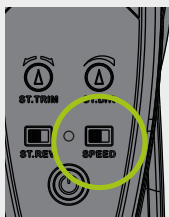

The speed switch is a throttle limiter. Turning the switch all the way down reduces the top speed to 40% of maximum speed. Turning the switch up increases the speed up to 100%.

7 BASIC TROUBLESHOOTING

7-5 Gyroscope

An RC car gyroscope is an electronic stability aid that automatically applies counter-steering to reduce spinning and sliding while improving straight-line control—particularly at high speeds or in rear-wheel-drive drift setups. Installed between the receiver and the steering servo, it detects unintended movement and makes real-time corrections to help the car handle more smoothly and predictably.

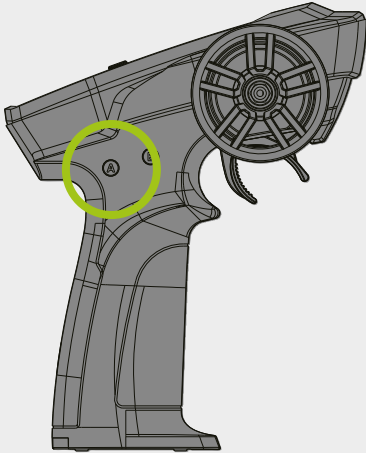

When the transmitter is powered on, the gyroscope function is off.

1. Press Button A once to activate Gyro Sensitivity Level 1 (The LED blinks once, then returns to green).
2. Press Button A again to activate Gyro Sensitivity Level 2 (The LED blinks twice, then returns to green).
3. Press Button A a third time to activate Gyro Sensitivity Level 3 (The LED blinks three times, then returns to green).
4. Press Button A a fourth time to deactivate the gyro function (The LED is off first and then returns to solid green)

Press Button A again to cycle through these settings repeatedly.

The transmitter will retain its last settings when powered on again, unless the batteries are replaced.

7-6 Track Steering Mode

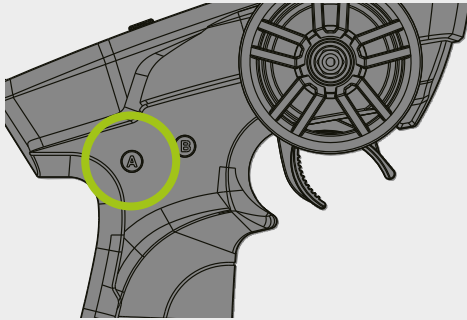

This mode enhances small-angle steering for better control

Press and hold the button A for 2–3 seconds to activate Track Steering Mode.

When enabled, the LED will flash red and then turn solid green during high-speed cornering.

To deactivate, press and hold the button again for 2–3 seconds.

When disabled, the LED will flash green and then turn solid green. (The factory default setting is off.)

7-7 Transmitter LED (during normal operation)

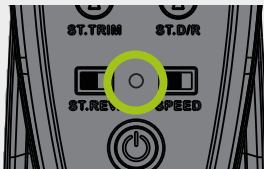

The LED on the transmitter will flash red twice continuously when the batteries are low. Please replace them with new batteries.

8 AFTER USE

8.1 Switch off Receiver

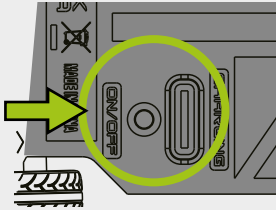

Press and hold for 2-3 sec. to switch off

8.2 Switch off Transmitter

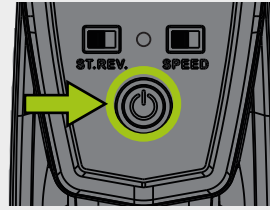

Press the power switch

**Caution**

If you switch off the transmitter first before the R/C car, you may lose control of the R/C car.

TROUBLESHOOTING

A. The vehicle does not work at all:

1. Check to ensure that radio controller and car are switched on.
2. Check if there are damaged parts/wires/connectors, repair or replace if necessary.
3. Car battery is flat. Charge the battery pack.

B. The vehicle runs slowly:

1. Car battery is flat. Charge the battery pack.
2. The throttle limiter is turned in too much (see page 7 of the instructions).
3. Check if the vehicle is properly geared and no dirty or stripped gears are found. Check the gear mesh for the motor pinion and spur gear.
4. Check if the moving parts have any problems and clean them immediately.

C. The throttle works but not the steering:

1. Check if the servo feels jammed, and try centering it gently if it does.
2. Check if the servo link is loose or if the servo is defective. Repair or replace if possible.

D. The vehicle steers, but there is no throttle control:

1. Check if there are damaged parts in the overall drive train.
2. Check the battery power both for radio controller and the car.

E. The vehicle drives noisily:

1. Check gear mesh between spur gear and motor pinion.
2. Check if there are stripped and/or dirty gears.
3. Check for any damage to any part throughout the drivetrain.

F. The vehicle does not steer the same amount in both directions.

1. Please adjust the steering trim until the steering center point is fixed.

G. Batteries cannot be charged:

1. Check if either the charger or the battery is damaged, or batteries are over-discharged.

FCC COMPLIANCE STATEMENT

This device transmits in the range 2.4 to 2.4835 GHz and has been tested to comply with the limits for a Part 15 Class B device of the FCC rules. These limits are designed to provide reasonable protection against harmful interference in a residential installation. This equipment generates, uses and can radiate radio frequency energy and, if not installed and used in accordance with the instructions, may cause harmful interference to radio communications. Any change or modification to the device not expressly approved by the manufacturer may void the user's authority to operate the equipment. Operation is subject to the following two conditions:

(1) This device may not cause harmful interference, and (2) This device must accept any interference received, including interference that may cause undesired operation.

Canada Compliance Statement:

This Class B digital apparatus complies with Canadian ICES-003. (Cet appareil numérique de la classe B est conforme à la norme NMB-003 du Canada.) This equipment complies with the FCC/IC radiation exposure limits set forth for FCC and Industry Canada portable transmitting devices operation in an uncontrolled environment. The equipment should only be used or installed at locations where there is normally at least a 20cm separation between the antenna and all persons. This transmitter must not be co-located or operated in conjunction with any other antenna or transmitter.

CE Compliance statement

The radio equipment type in this product transmits in the frequency range 2.4 to 2.4835 GHz with a maximum power of 18dBm and is in compliance with EU Directive 2014/53/EU. The full text of the Declaration of Conformity is available at www.hpiracing.com/ce

BLACKZON

HPI RACING A/S

Jegindoevej 21

8800 Viborg, Denmark

WWW.BLACKZON.COM