

1/8 LUXURY ELECTRIC OFF-ROAD BUGGY

XRAY XB8E

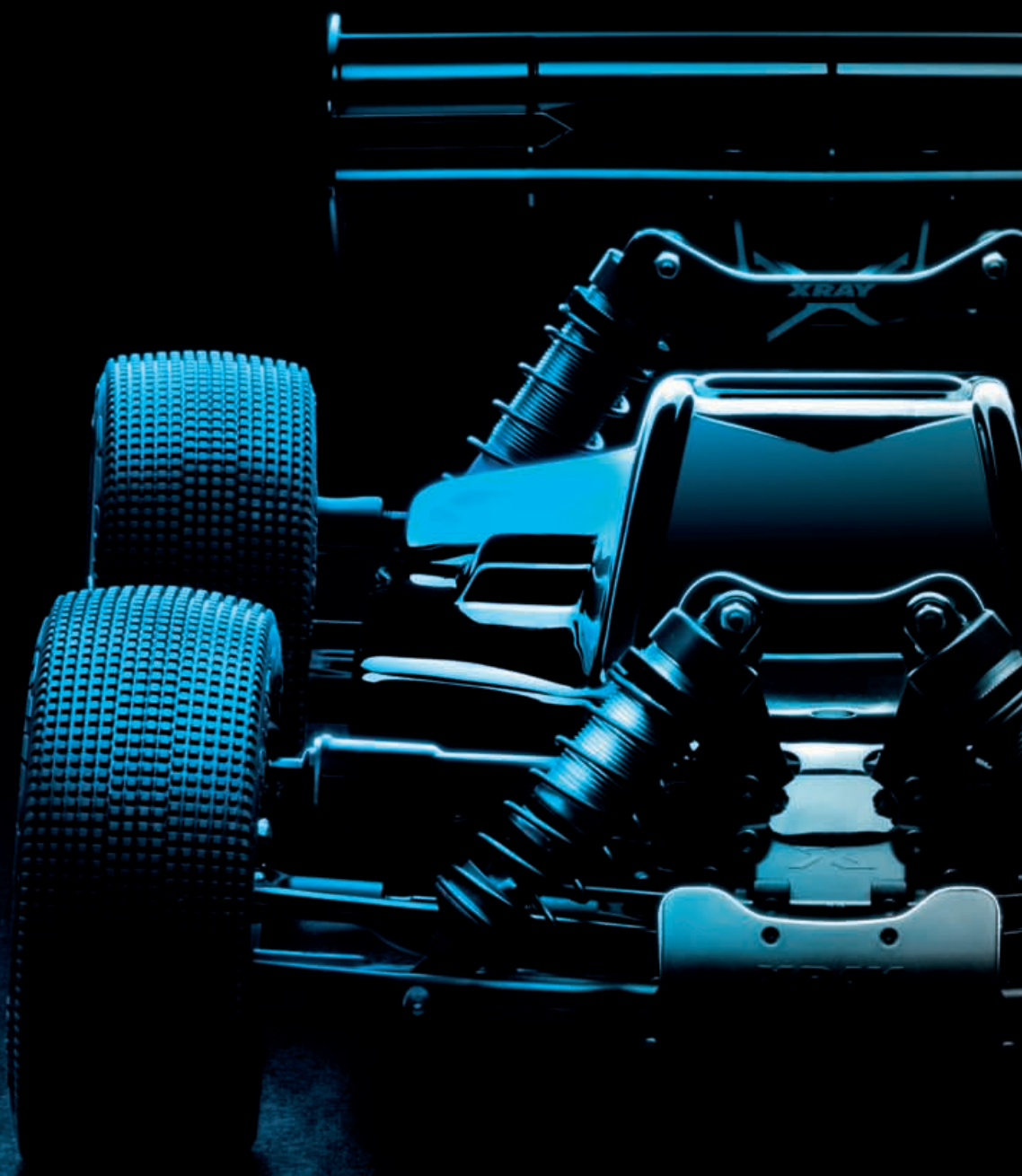

INSTRUCTION MANUAL

XRAY XB8E'22

BEFORE YOU START

This is a high-competition, high-quality RC car intended for persons aged 16 years and older with previous experience building and operating RC model racing cars. This is not a toy; it is a precision racing model. This model racing car is not intended for use by beginners, inexperienced customers, or by children without direct supervision of a responsible, knowledgeable adult. If you do not fulfill these requirements, please return the kit in unused and unassembled form back to the shop where you have purchased it.

Before building and operating your XRAY, **YOU MUST** read through all of the operating instructions and instruction manual and fully understand them to get the maximum enjoyment and prevent unnecessary damage.

CUSTOMER SUPPORT

We have made every effort to make these instructions as easy to understand as possible. However, if you have any difficulties, problems, or questions, please do not hesitate to contact the XRAY support team at info@teamxray.com. Also, please visit our Web site at www.teamxray.com to find the latest updates, set-up information, option parts, and many other goodies. We pride ourselves on taking excellent care of our customers.

You can join thousands of XRAY fans and enthusiasts in our online community at: www.teamxray.com

Read carefully and fully understand the instructions before beginning assembly.

Make sure you review this entire manual, download and use set-up book from the web, and examine all details carefully. If for some reason you decide this is not what you wanted or expected, **do not continue any further**. Your hobby dealer can not accept your kit for return or exchange after it has been partially or fully assembled.

Contents of the box may differ from pictures. In line with our policy of continuous product development, the exact specifications of the kit may vary without prior notice.

XRAY Europe

K Vystavisku 6992
91101 Trenčín
Slovakia, EUROPE
Phone: 421-32-7401100
Fax: 421-32-7401109
E-mail: info@teamxray.com

XRAY USA

RC America, 2030 Century Center Blvd #15
Irving, TX 75062
USA
Phone: (214) 744-2400
Fax: (214) 744-2401
E-mail: xray@rcamerica.com

FAILURE TO FOLLOW THESE INSTRUCTIONS WILL BE CONSIDERED AS ABUSE AND/OR NEGLIGENCE.

SAFETY PRECAUTIONS

Contains:

LEAD (CAS 7439-92-1) ANTIMONY (CAS 7440-36-0)

WARNING: This product contains a chemical known to the state of California to cause cancer and birth defects or other reproductive harm.

CAUTION: CANCER HAZARD

Contains lead, a listed carcinogen. Lead is harmful if ingested. Wash thoroughly after using. DO NOT use product while eating, drinking or using tobacco products. May cause chronic effects to gastrointestinal tract, CNS, kidneys, and blood. MAY CAUSE BIRTH DEFECTS.

When building, using and/or operating this model always wear protective glasses and gloves.

Take appropriate safety precautions prior to operating this model. You are responsible for this model's assembly and safe operation! Please read the instruction manual before building and operating this model and follow all safety precautions. Always keep the instruction manual at hand for quick

reference, even after completing the assembly. Use only genuine and original authentic XRAY parts for maximum performance. Using any third party parts on this model will void guaranty immediately.

Improper operation may cause personal and/or property damage. XRAY and its distributors have no control over damage resulting from shipping, improper construction, or improper usage. XRAY assumes and accepts no responsibility for personal and/or property damages resulting from the use of improper building materials, equipment and operations. By purchasing any item produced by XRAY, the buyer expressly warrants that he/she is in compliance with all applicable federal, state and local laws and regulation regarding the purchase, ownership and use of the item. The buyer expressly agrees to indemnify and hold harmless XRAY for all claims resulting directly or indirectly from the purchase, ownership or use of the product. By the act of assembling or operating this product, the user accepts all resulting liability. If the buyer is not prepared to accept this liability, then he/she should return this kit in new, unassembled, and unused condition to the place of purchase.



IMPORTANT NOTES - GENERAL

- This product is not suitable for children under 16 years of age without the direct supervision of a responsible and knowledgeable adult.
- Carefully read all manufacturers warnings and cautions for any parts used in the construction and use of your model.
- Assemble this kit only in places away from the reach of very small children.
- First-time builders and users should seek advice from people who have building experience in order to assemble the model correctly and to allow the model to reach its performance potential.
- Exercise care when using tools and sharp instruments.
- Take care when building, as some parts may have sharp edges.
- Keep small parts out of reach of small children. Children must not be allowed to put any parts in their mouth, or pull vinyl bag over their head.
- Read and follow instructions supplied with paints and/or cement, if used (not included in kit).
- Immediately after using your model, do NOT touch equipment on the model such as the motor and speed controller, because they generate high temperatures. You may seriously burn yourself seriously touching them.
- Follow the operating instructions for the radio equipment at all times.
- Do not put fingers or any objects inside rotating and moving parts, as this may cause damage or serious injury as your finger, hair, clothes, etc. may get caught.
- Be sure that your operating frequency is clear before turning on or running your model, and never share the same frequency with somebody else at the same time. Ensure that others are aware of the operating frequency you are using and when you are using it.
- Use a transmitter designed for ground use with RC cars. Make sure that no one else is using the same frequency as yours in your operating area. Using the same frequency at the same time, whether it is driving, flying or sailing, can cause loss of control of the RC model, resulting in a serious accident.
- Always turn on your transmitter before you turn on the receiver in the car. Always turn off the receiver before turning your transmitter off.
- Keep the wheels of the model off the ground when checking the operation of the radio equipment.
- Disconnect the battery pack before storing your model.
- When learning to operate your model, go to an area that has no obstacles that can damage your model if your model suffers a collision.
- Remove any sand, mud, dirt, grass or water before putting your model away.
- If the model behaves strangely, immediately stop the model, check and clear the problem.
- To prevent any serious personal injury and/or damage to property, be responsible when operating all remote controlled models.
- The model car is not intended for use on public places and roads or areas where its operation can conflict with or disrupt pedestrian or vehicular traffic.
- Because the model car is controlled by radio, it is subject to radio interference from many sources that are beyond your control. Since radio interference can cause momentary loss of control, always allow a safety margin in all directions around the model in order to prevent collisions.
- Do not use your model:
 - Near real cars, animals, or people that are unaware that an RC car is being driven.
 - In places where children and people gather
 - In residential districts and parks
 - In limited indoor spaces
 - In wet conditions
 - In the street
 - In areas where loud noises can disturb others, such as hospitals and residential areas.
 - At night or anytime your line of sight to the model may be obstructed or impaired in any way.

To prevent any serious personal injury and/or damage to property, please be responsible when operating all remote controlled models.

IMPORTANT NOTES - ELECTRICAL

- Insulate any exposed electrical wiring (using heat shrink tubing or electrical tape) to prevent dangerous short circuits. Take maximum care in wiring, connecting and insulating cables. Make sure cables are always connected securely. Check connectors for if they become loose. And if so, reconnect them securely. Never use RC models with damaged wires. A damaged wire is extremely dangerous, and can cause short-circuits resulting in fire. Please have wires repaired at your local hobby shop.
- Low battery power will result in loss of control. Loss of control can occur due to a weak battery in either the transmitter or the receiver. Weak running battery may also result in an out of control car if your car's receiver power is supplied by the running battery. Stop operation immediately if the car starts to slow down.
- When not using RC model, always disconnect and remove battery.
- Do not disassemble battery or cut battery cables. If the running battery short-circuits, approximately 300W of electricity can be discharged, leading to fire or burns. Never disassemble battery or cut battery cables.
- Use a recommended charger for the receiver and transmitter batteries and follow the instructions correctly. Over-charging, incorrect charging,

- or using inferior chargers can cause the batteries to become dangerously hot. Recharge battery when necessary. Continual recharging may damage battery and, in the worst case, could build up heat leading to fire. If battery becomes extremely hot during recharging, please ask your local hobby shop for check and/or repair and/or replacement.
- Regularly check the charger for potential hazards such as damage to the cable, plug, casing or other defects. Ensure that any damage is rectified before using the charger again. Modifying the charger may cause short-circuit or overcharging leading to a serious accident. Therefore do not modify the charger.
- Always unplug charger when recharging is finished.
- Do not recharge battery while battery is still warm. After use, battery retains heat. Wait until it cools down before charging.
- Do not allow any metal part to short circuit the receiver batteries or other electrical/electronic device on the model.
- Immediately stop running if your RC model gets wet as may cause short circuit.
- Please dispose of batteries responsibly. Never put batteries into fire.

R/C & BUILDING TIPS

- Make sure all fasteners are properly tightened. Check them periodically.
- Make sure that chassis screws do not protrude from the chassis.
- For the best performance, it is very important that great care is taken to ensure the free movement of all parts.
- Clean all ball-bearings so they move very easily and freely.
- Tap or pre-thread the plastic parts when threading screws.
- Self-tapping screws cut threads into the parts when being tightened. Do not use excessive force when tightening the self-tapping screws because you may strip out the thread in the plastic. We recommended you stop tightening a screw when you feel some resistance.
- Ask your local hobby shop for any advice.

Please support your local hobby shop. We at XRAY Model Racing Cars support all local hobby dealers. Therefore we ask you, if at all possible, to purchase XRAY products at your hobby dealer and give them your support like we do. If you have difficulty finding XRAY products, please check out www.teamxray.com to get advice, or contact us via email at info@teamxray.com, or contact the XRAY distributor in your country.

WARRANTY

XRAY guarantees this model kit to be free from defects in both material and workmanship within 30 days of purchase. The total monetary value under warranty will in no case exceed the cost of the original kit purchased. This warranty does not cover any components damaged by use or modification or as a result of wear. Part or parts missing from this kit must be reported within 30 days of purchase. No part or parts will be sent under warranty without proof of purchase. Should you find a defective or missing part, contact the local distributor. Service and customer support will be provided through local hobby store where you have purchased the kit, therefore make sure to purchase any XRAY products at your local hobby store. This model racing car is considered to be a high-performance racing vehicle. As such this vehicle will be used in an extreme range of conditions and situations, all which may cause premature wear or failure of any component. XRAY has no control over usage of vehicles once they leave the dealer, therefore XRAY can only offer warranty against all manufacturer's defects in materials, workmanship, and assembly at point of sale and before use. No warranties are expressed or implied that cover damage caused by what is considered normal use, or cover or imply how long any model cars' components or electronic components will last before requiring replacement.

Due to the high performance level of this model car you will need to periodically maintain and replace consumable components. Any and all warranty coverage will not cover replacement of any part or component damaged by neglect, abuse, or improper or unreasonable use. This includes

but is not limited to damage from crashing, chemical and/or water damage, excessive moisture, improper or no maintenance, or user modifications which compromise the integrity of components. Warranty will not cover components that are considered consumable on RC vehicles. XRAY does not pay nor refund shipping on any component sent to XRAY or its distributors for warranty. XRAY reserves the right to make the final determination of the warranty status of any component or part.

Limitations of Liability

XRAY makes no other warranties expressed or implied. XRAY shall not be liable for any loss, injury or damages, whether direct, indirect, special, incidental, or consequential, arising from the use, misuse, or abuse of this product and/or any product or accessory required to operate this product. In no case shall XRAY's liability exceed the monetary value of this product.

Take adequate safety precautions prior to operating this model. You are responsible for this model's assembly and safe operation.

Disregard of the any of the above cautions may lead to accidents, personal injury, or property damage. XRAY MODEL RACING CARS assumes no responsibility for any injury, damage, or misuse of this product during assembly or operation, nor any additions that may arise from the use of this product.

All rights reserved.

QUALITY CERTIFICATE

XRAY MODEL RACING CARS uses only the highest quality materials, the best compounds for molded parts and the most sophisticated manufacturing processes of TQM (Total Quality Management). We guarantee that all parts of a newly-purchased kit are manufactured with the highest regard to quality. However, due to the many factors inherent in model racecar competition, we

cannot guarantee any parts once you start racing the car. Products which have been worn out, abused, neglected or improperly operated will not be covered under warranty.

We wish you enjoyment of this high-quality and high-performance RC car and wish you best success on the track!

In line with our policy of continuous product development, the exact specifications of the kit may vary. In the unlikely event of any problems with your new kit, you should contact the model shop where you purchased it, quoting the part number.

We do reserve all rights to change any specification without prior notice. All rights reserved.



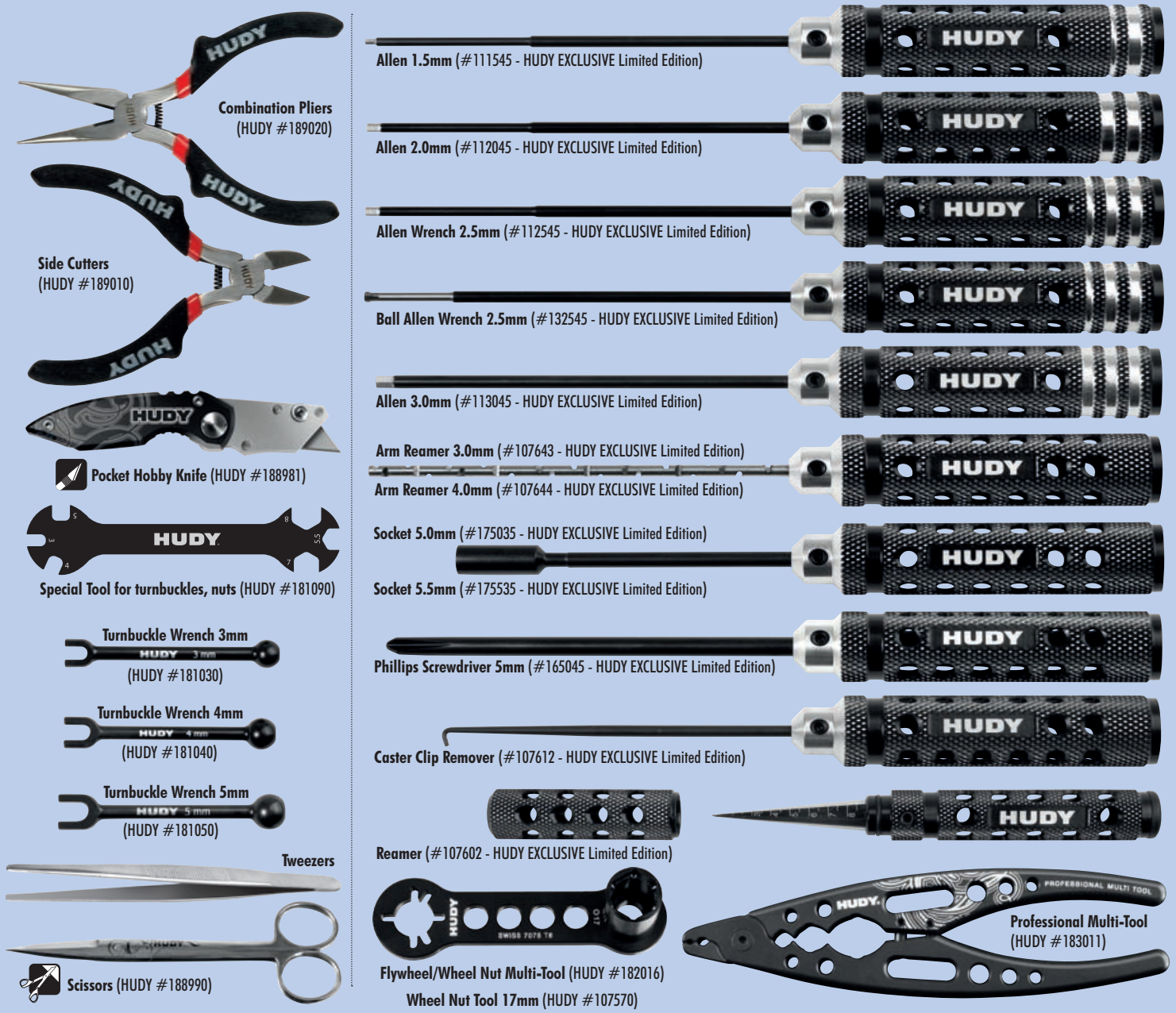

TOOLS REQUIRED



EQUIPMENT REQUIRED

Transmitter 	Receiver 	Speed Controller 	Steering Servo 	Battery Charger
Electric Motor 	Pinion Gear 	Lexan™ Paint 	LiPo Battery Saddle Pack (Short) 	
Double-sided Tape (HUDY #107875) 	Tires & Wheels 	Bearing Oil (HUDY #106230) 	Threadlock 	CA glue

EQUIPMENT INCLUDED * Kit includes smaller but sufficient amount of oil and grease to build the car.

<p>550cSt (#106356) HUDY Premium Silicone Oils</p>  <p>OIL</p>	<p>600cSt (#106361) HUDY Premium Silicone Oils</p>  <p>OIL</p>	<p>3.000cSt (#106431) HUDY Premium Silicone Oils</p>  <p>OIL</p>	<p>7.000cSt (#106471) HUDY Premium Silicone Oils</p>  <p>OIL</p>	<p>(HUDY #106210) Premium Graphite Grease</p>  <p>GR</p>
--	--	--	--	--

At the beginning of each section is an exploded view of the parts to be assembled. There is also a list of all the parts and part numbers that are related to the assembly of that section. The part descriptions are color-coded to make it easier for you to identify the source of a part. Here are what the different colors mean:

STYLE A - indicates parts that are included in the bag marked for the section.
STYLE B - indicates parts that are included in the box.
STYLE C - indicates parts that are already assembled from previous steps.

XB8 TECH TIPS

TIP FRONT & REAR DIFF GEAR MESH ADJUSTMENT

If there is too much or too little diff side play, this may create non-optimal gear mesh between the diff gear and the pinion drive gear. This is easily resolved by inserting 1 or 2 of the included thin shims behind a diff outdrive ball-bearing, depending on how much play there is.

THE LOCATION OF THE SHIM(S) DEPENDS ON WHETHER YOU ARE TRYING TO CLOSE OR OPEN THE GAP.

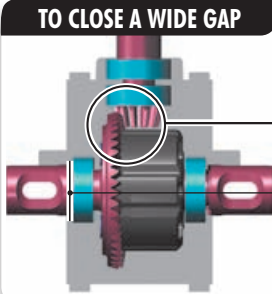
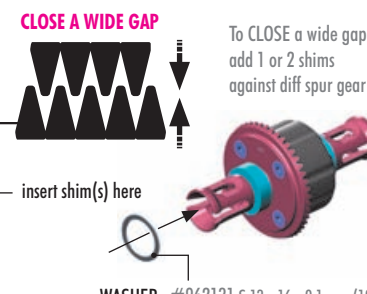
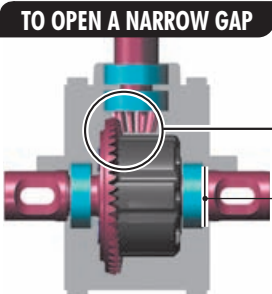
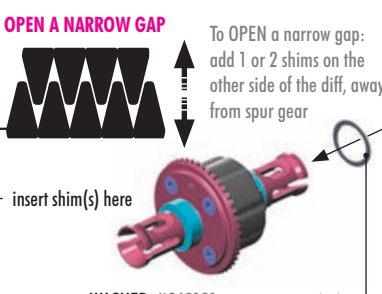
<p>TO CLOSE A WIDE GAP</p>  <p>insert shim(s) here</p>	<p>CLOSE A WIDE GAP</p>  <p>To CLOSE a wide gap: add 1 or 2 shims against diff spur gear</p> <p>WASHER #962131 S 13 x 16 x 0.1 mm (10) #962130 S 13 x 16 x 0.2 mm (10)</p>	<p>TO OPEN A NARROW GAP</p>  <p>insert shim(s) here</p>	<p>OPEN A NARROW GAP</p>  <p>To OPEN a narrow gap: add 1 or 2 shims on the other side of the diff, away from spur gear</p> <p>WASHER #962131 S 13x16x0.1mm (10) #962130 S 13x16x0.2mm (10)</p>
--	---	---	---

CHECK GEAR MESH AND DIFF PLAY ONLY AFTER THE ENTIRE GEARBOX IS MOUNTED TOGETHER WITH THE SUSPENSION HOLDERS ON THE CHASSIS. ALL PARTS ARE DESIGNED TO HAVE CERTAIN PLAY AND IT IS ALL DESIGNED BY PURPOSE.

SUSPENSION & DRIVETRAIN MAINTENANCE





- Check suspension for free movement during building and operation, and especially after running and if you have crashed the car. If the suspension does not move freely, use the appropriate HUDY Arm Reamer to clean and resize the holes of the suspension arms.
- Regularly check the drive shaft pins (both side and center) and if they show any wear must be immediately replaced by new pins. If the car is run with worn pins, excessive wear on the diff outdrives will result. The 106000 HUDY Drive Pin Replacement Tool (for 3mm Pins) is a compact, rugged multi-use tool set for replacing 3mm drive pins in drive shafts. Use the HUDY replacement drive shaft pins 3x14 (#106050).
- Regularly inspect and replace the connecting pins which connect the center drive shafts with the pinion gear, and also the pins that connect the wheel drive shafts with wheel axles. Use HUDY Graphite Grease to lubricate the drive shaft connecting joints and the diff gears.
- Pivot balls and ball-joints will naturally wear for some time and will generate play. If there is too much play the pivot balls and ball joints need to be replaced.
- If the car is run in wet conditions, apply WD-40® on all drivetrain parts before the run. After the run, clean and dry the parts again.

HUDY SPRING STEEL™

The HUDY Spring Steel™ used in the car is the strongest and most durable steel material on the RC market. While items made from HUDY Spring Steel™ are still subject to wear, the lifespan is considerably longer than any other material. As parts made from HUDY Spring Steel™ wear, the brown color will after some time "go down" but it will not affect the strength of the material. The brown color is only a surface treatment and if the brown color will wear the durability of the part will be still strong.

TIP DRIVE SHAFT PIN SERVICING

To enjoy the longest possible lifespan of the drive shafts and diff outdrives, it is extremely important to properly service the drive shaft pins. Inspect the pins after every 3 hours of runtime. If the pins show any wear, replace them with new pins.

<p>1</p>  <p>Do not use drive shafts when the pins are worn.</p>	<p>2</p>  <p>Press out the worn pins.</p>	<p>3</p>  <p>Press in new pins and regularly inspect for wear.</p>	 <p>For easy drive pin replacements use #106000 HUDY Drive Pin Replacement Tool.</p>	 <p>To replace the worn pins use only premium HUDY drive pins #106050.</p>
---	---	--	--	---

1. FRONT & REAR DIFFERENTIALS



XRAY BALL-BEARINGS

OPTION	Part #	Size	Lubricant	Material	Status
	#930816	8x16x5	GREASE	STEEL	OPTION
	#930817	8x16x5	OIL	STEEL	OPTION
	#940816	8x16x5	GREASE	RUBBER	INCLUDED
	#940817	8x16x5	OIL	RUBBER	OPTION

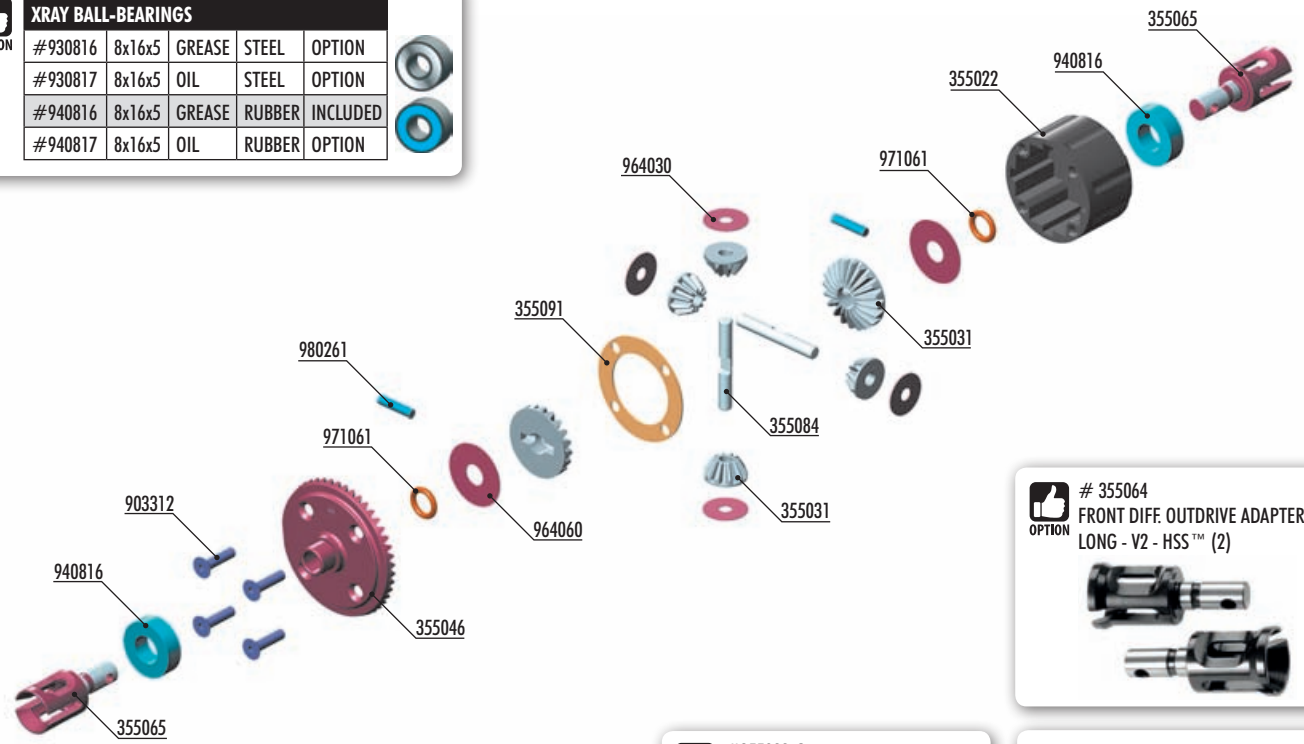

355064
OPTION FRONT DIFF. OUTDRIVE ADAPTER LONG - V2 - HSS™ (2)

#355022-G
OPTION DIFFERENTIAL CASE - V2 - GRAPHITE

#355086
OPTION HEAT-RESISTANT F/R ALU DIFF PINS + INSERTS (SET)

BAGS



2x

- 355005 DIFFERENTIAL 46T - V2 - SET
- 355022 DIFFERENTIAL CASE - V2
- 355031 STEEL DIFF BEVEL & SATELLITE GEARS - V2 (2+4)
- 355046 FRONT/REAR DIFF LARGE BEVEL GEAR 46T - HUDY STEEL
- 355065 DIFF OUTDRIVE ADAPTER - V2 - HUDY SPRING STEEL™ (2)
- 355084 F/R DIFF PIN (2)
- 355091 F/R DIFF GASKET (4)

- 903312 HEX SCREW SFH M3x12 (10)
- 940816 BALL-BEARING 8x16x5 RUBBER SEALED - GREASE (2)
- 964030 WASHER S 3.5x12x0.2 (10)
- 964060 WASHER S 6x18x0.2 (10)
- 971061 SILICONE O-RING 6x1.55 (10)
- 980261 PIN 2.5x11.5 (10)

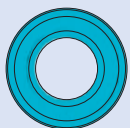

940816
BB 8x16x5



964060
S 6x18x0.2



971061
O 6x1.55



980261
P 2.5x11.5

2x F=R

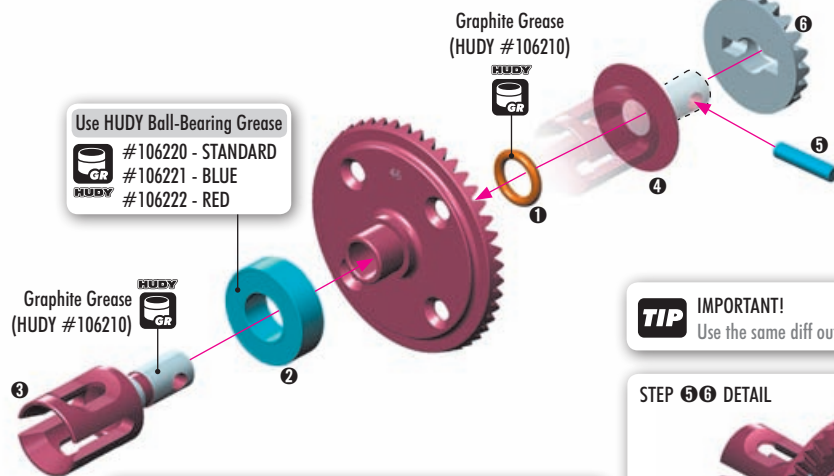

Use HUDY Ball-Bearing Grease
 #106220 - STANDARD
 #106221 - BLUE
 #106222 - RED

Graphite Grease (HUDY #106210)

Graphite Grease (HUDY #106210)

TIP IMPORTANT!
 Use the same diff outdrives on both ends of a diff.

STEP 5 6 DETAIL

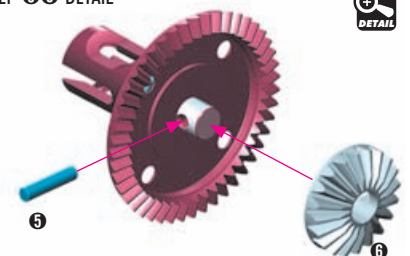

XRAY BALL-BEARINGS

OPTION	Part #	Size	Lubricant	Material	Status
	#930816	8x16x5	GREASE	STEEL	OPTION
	#930817	8x16x5	OIL	STEEL	OPTION
	#940816	8x16x5	GREASE	RUBBER	INCLUDED
	#940817	8x16x5	OIL	RUBBER	OPTION



SET-UP BOOK
 DIFFERENTIAL GEARS

1. FRONT & REAR DIFFERENTIALS



940816
BB 8x16x5

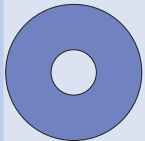

964060
S 6x18x0.2



971061
O 6x1.55

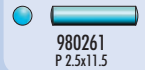

980261
P 2.5x11.5

2x F=R

TIP IMPORTANT!
Use the same diff outrides on both ends of a diff.

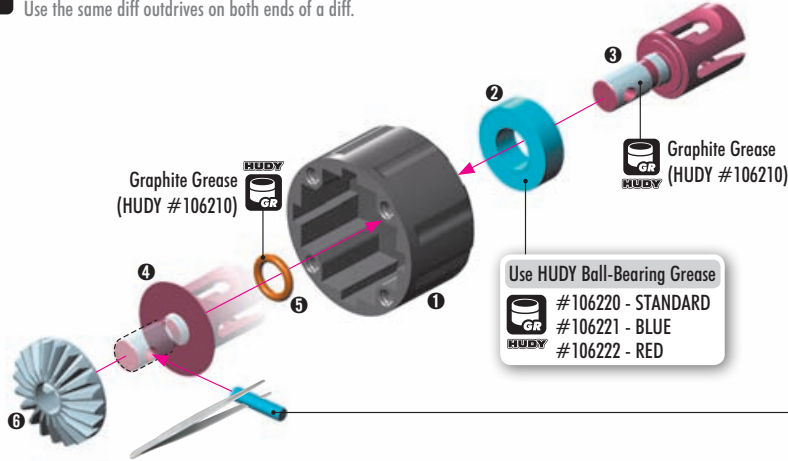

VERY IMPORTANT!

Use the following silicone oils included in the kit for initial settings:
FRONT diff: 7.000cSt / REAR diff: 3.000cSt

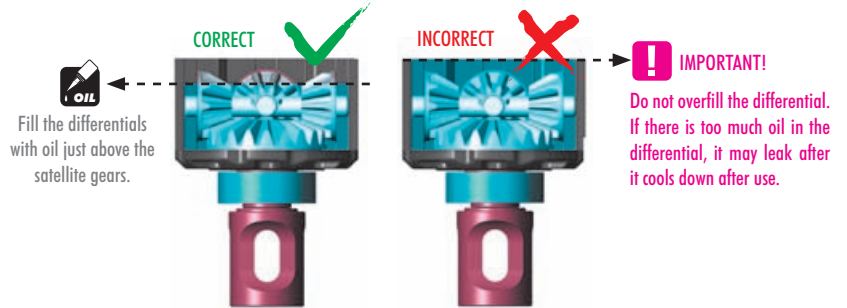

Fill the differentials with oil just above the satellite gears.

IMPORTANT!
Do not overfill the differential. If there is too much oil in the differential, it may leak after it cools down after use.

To ensure you have the same amount of oil from rebuild to rebuild, do the following:

#107865 HUDY Ultimate Digital Pocket Scale 300g ± 0.01g



- Put the diff (without oil) on the scale and check the weight:
 - REAR DIFF approx. 39.30g
 - FRONT DIFF approx. 39.30g

- Slowly pour oil into the diff and watch the weight. Add 2.60g of oil into the diff. The approximate weight of the diff+oil is approx. 41.90g.

$$\text{REAR DIFF } 39.30\text{g} + 2.60\text{g} = 41.90\text{g}$$

$$\text{FRONT DIFF } 39.30\text{g} + 2.60\text{g} = 41.90\text{g}$$

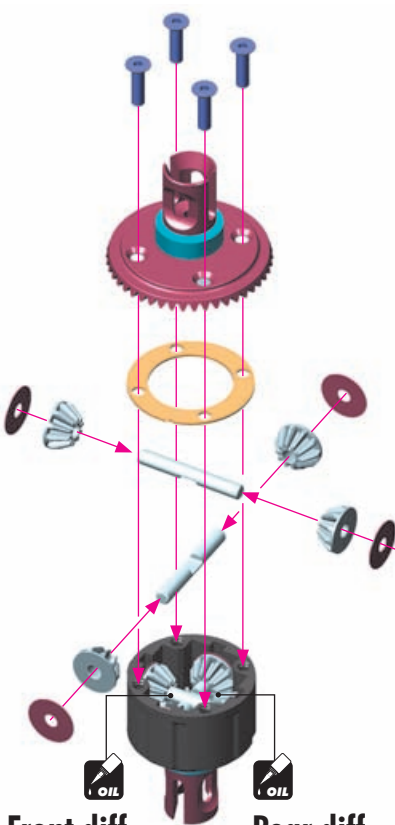

Front diff:

Silicone oil 7.000cSt
Fill just above the satellite gears.

Rear diff:

Silicone oil 3.000cSt
Fill just above the satellite gears.

SET-UP BOOK
DIFFERENTIAL OIL

Tighten the screws equally.



Finish tightening in this order:

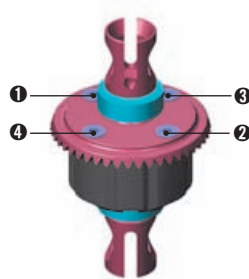

After assembly the differentials should have a length of 32.3~32.5 mm measured from the ends of the installed ball-bearings. If differentials are longer, retighten the 4 screws holding the crown gears.

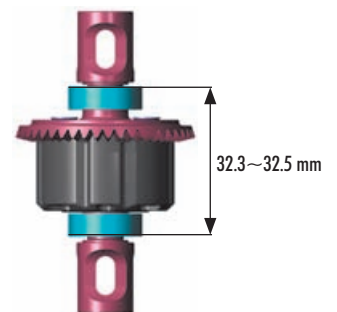

1. CENTER DIFFERENTIAL



XRAY BALL-BEARINGS

OPTION	Part #	Size	Lubricant	Material	Status
	#930816	8x16x5	GREASE	STEEL	OPTION
	#930817	8x16x5	OIL	STEEL	OPTION
	#940816	8x16x5	GREASE	RUBBER	INCLUDED
	#940817	8x16x5	OIL	RUBBER	OPTION



CENTER DIFF SPUR GEARS - LARGE

OPTION	Part #	Teeth	Status
	#355056	46T	INCLUDED
	#355057	47T	OPTION
	#355058	48T	OPTION

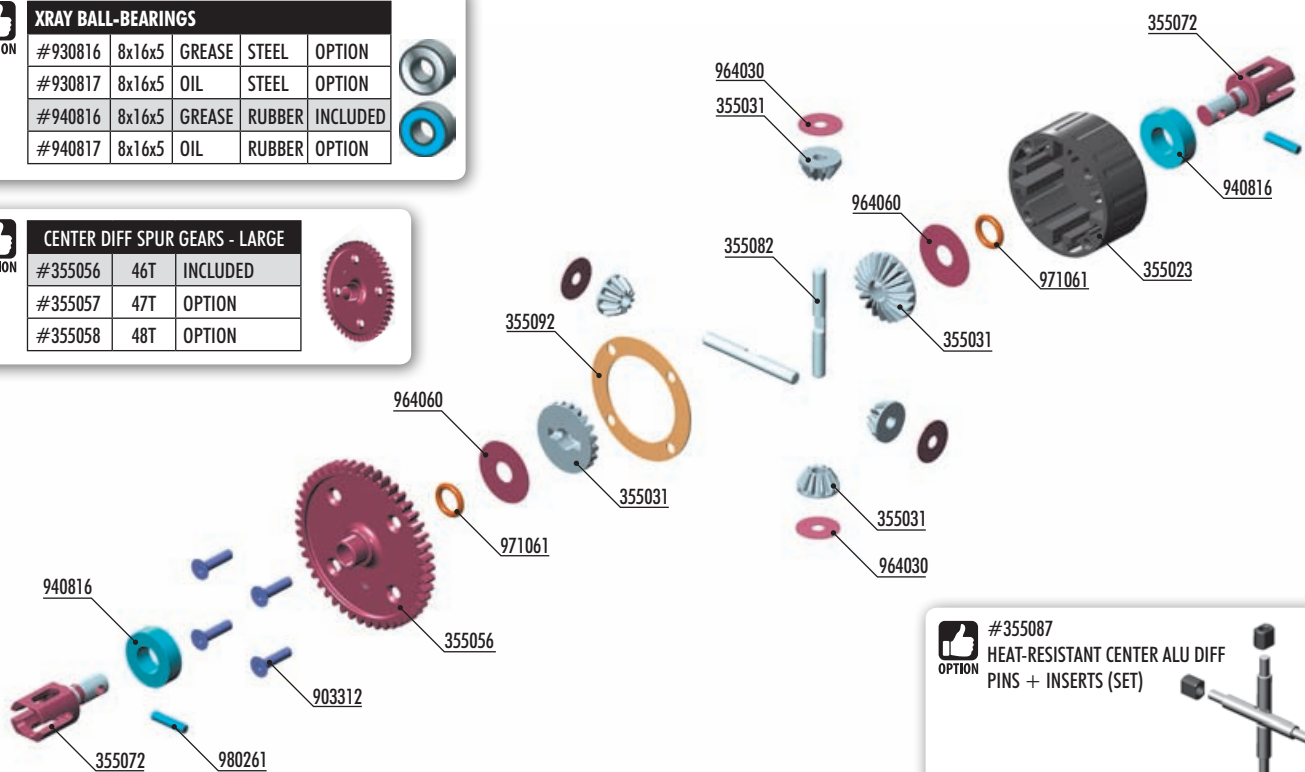

#355012
CENTER DIFFERENTIAL - V1 - SET



#355023-G
CENTER DIFFERENTIAL CASE - V2 - GRAPHITE



#355087
HEAT-RESISTANT CENTER ALU DIFF PINS + INSERTS (SET)

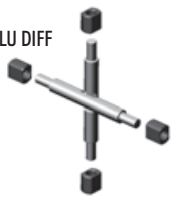

#355083
HEAT-RESISTANT CENTER STEEL DIFF PIN + INSERTS (SET)

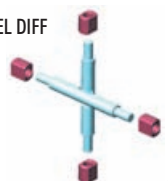

BAG

01.3

- 355013 CENTER DIFFERENTIAL - LARGE - SET - V2
- 355023 CENTER DIFFERENTIAL CASE - V2
- 355031 STEEL DIFF BEVEL & SATELLITE GEARS - V2 (2+4)
- 355056 CENTER DIFF SPUR GEAR 46T - LARGE
- 355072 LARGE CENTER DIFF OUTDRIVE ADAPTER - HUDY STEEL (2)
- 355082 CENTER DIFF PIN (2)
- 355092 CENTER DIFF GASKET (2)

- 903312 HEX SCREW SFH M3x12 (10)
- 940816 BALL-BEARING 8x16x5 RUBBER SEALED - GREASE (2)
- 964030 WASHER S 3.5x12x0.2 (10)
- 964060 WASHER S 6x18x0.2 (10)
- 971061 SILICONE O-RING 6x1.55 (10)
- 980261 PIN 2.5x11.5 (10)

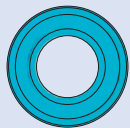

940816
BB 8x16x5



964060
S 6x18x0.2



971061
O 6x1.55



980261
P 2.5x11.5

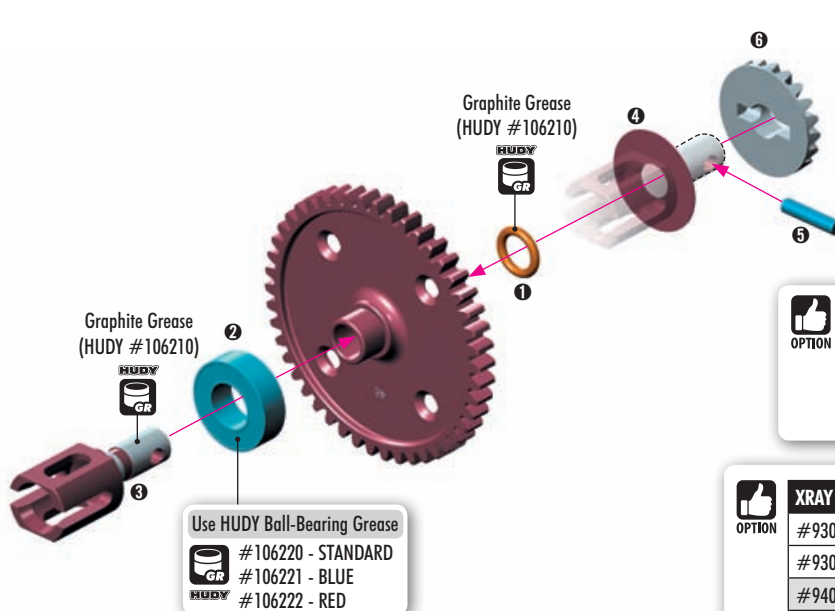

STEP 5 6 DETAIL

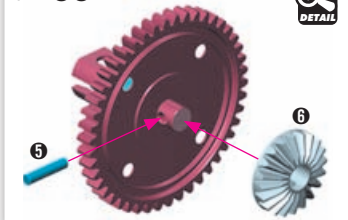

Graphite Grease
(HUDY #106210)

Use HUDY Ball-Bearing Grease

- #106220 - STANDARD
- #106221 - BLUE
- #106222 - RED



CENTER DIFF SPUR GEARS - LARGE

OPTION	Part #	Teeth	Status
	#355056	46T	INCLUDED
	#355057	47T	OPTION
	#355058	48T	OPTION



XRAY BALL-BEARINGS

OPTION	Part #	Size	Lubricant	Material	Status
	#930816	8x16x5	GREASE	STEEL	OPTION
	#930817	8x16x5	OIL	STEEL	OPTION
	#940816	8x16x5	GREASE	RUBBER	INCLUDED
	#940817	8x16x5	OIL	RUBBER	OPTION



1. CENTER DIFFERENTIAL



940816
BB 8x16x5



964060
S 6x18x0.2



971061
O 6x1.55



980261
P 2.5x11.5

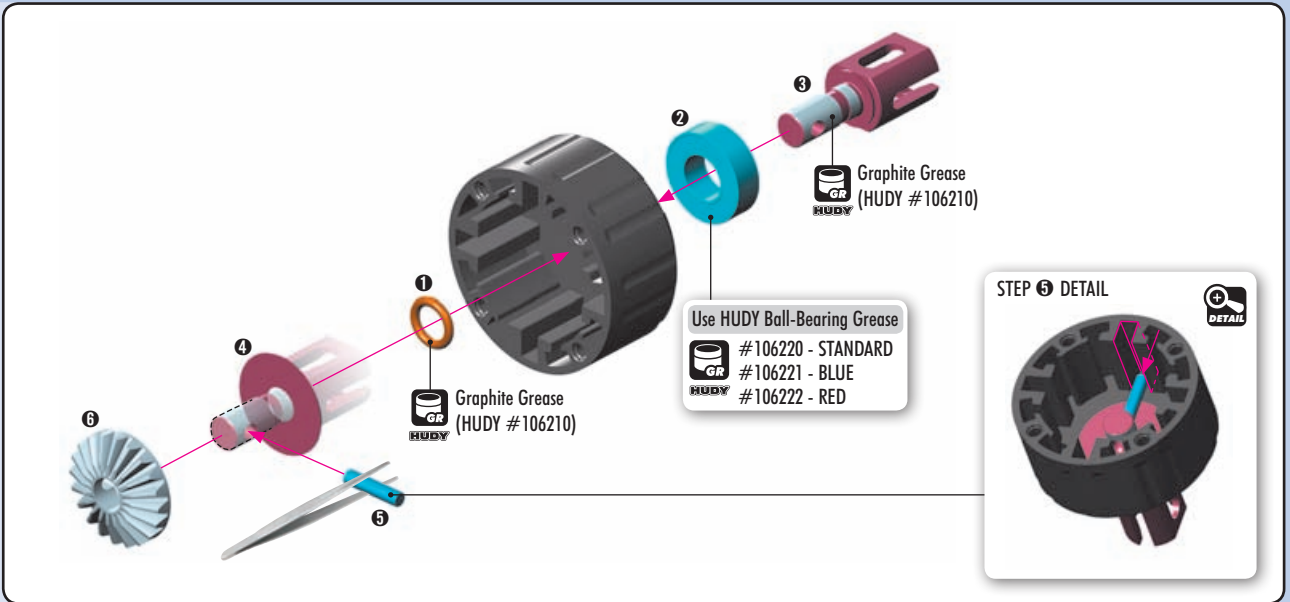

903312
SFH M3x12



964030
S 3.5x12x0.2

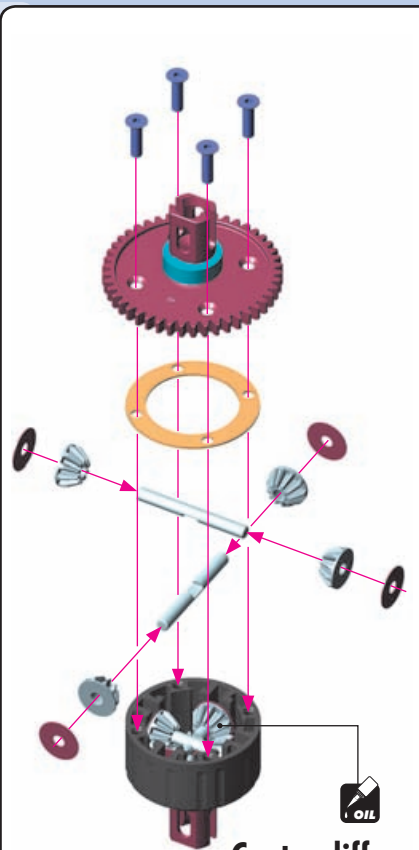

Center diff:

Silicone oil 7.000cSt

Fill to just above the satellite gears.

VERY IMPORTANT!

Use the following silicone oil included in the kit for initial setting:
Center diff: 7.000cSt

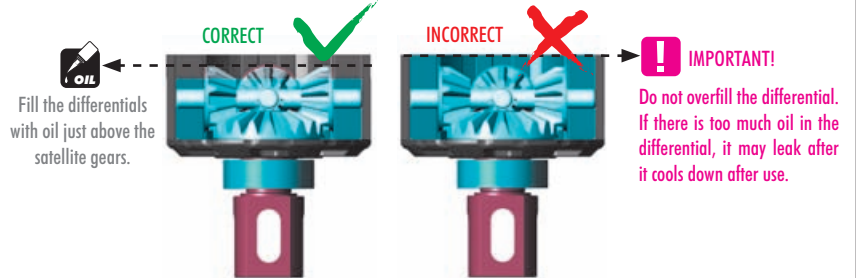

To ensure you have the same amount of oil from rebuild to rebuild, do the following:

#107865 HUDY Ultimate Digital Pocket Scale 300g ± 0.01g

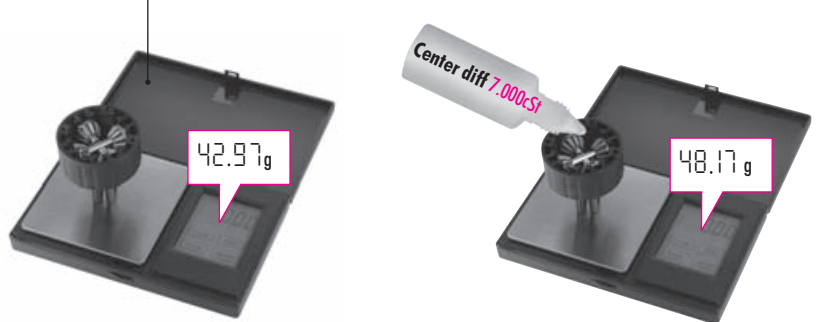

1. Put the diff (without oil) on the scale and check the weight (approximately 42.97g).

2. Slowly pour oil into the diff and watch the weight. Add 5.20g of oil into the diff. The approximate weight of the diff+oil is 48.17g.

$$\text{CENTER DIFF } 42.97\text{g} + 5.20\text{g} = 48.17\text{g}$$

SET-UP BOOK
DIFFERENTIAL OIL

Tighten the screws equally.



Finish tightening in this order:

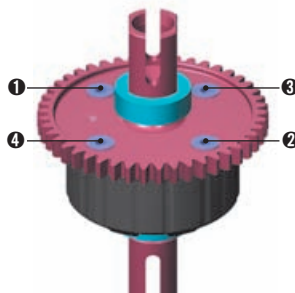

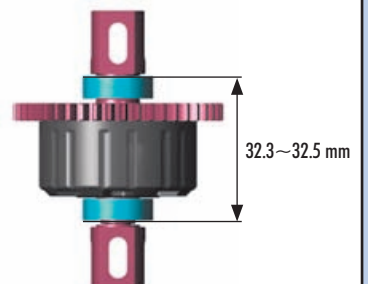

After assembly the differential should have a length of 32.3~32.5 mm measured from the ends of the installed ball-bearings. If differential is longer, retighten the 4 screws holding the spur gear.

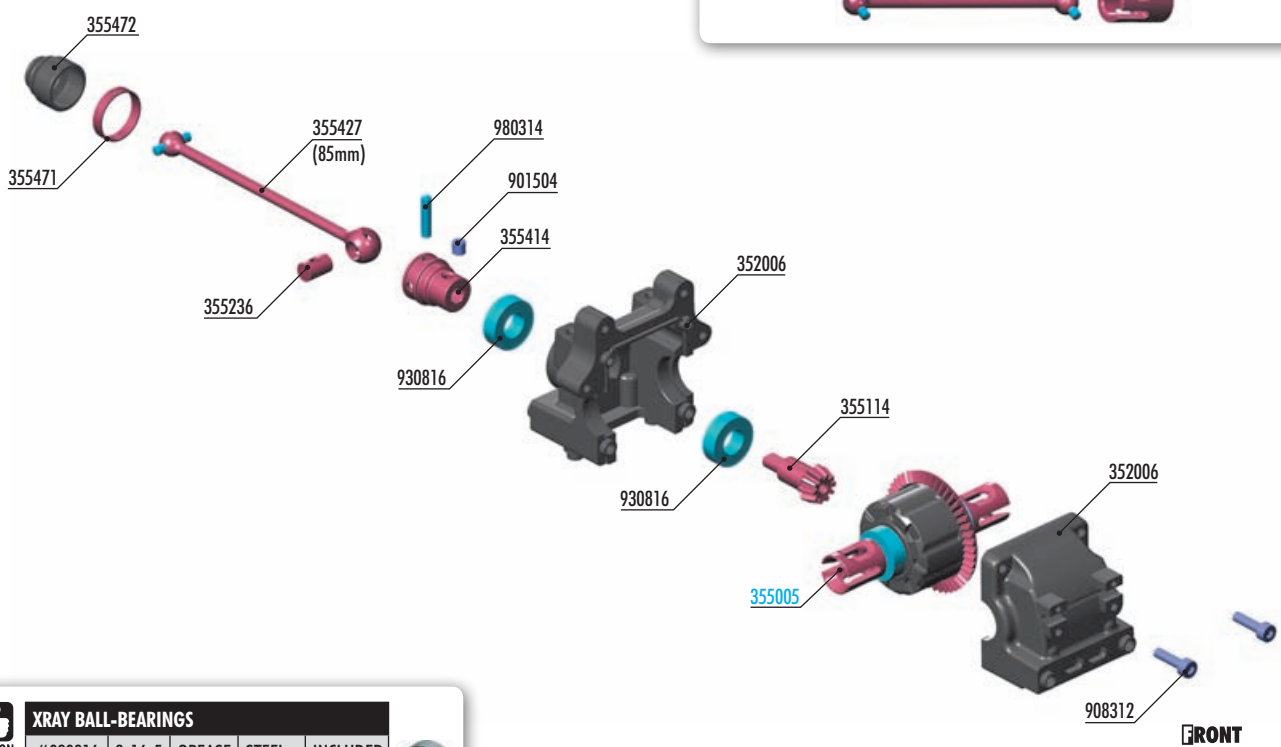

2. FRONT TRANSMISSION

OPTION  #355415 CENTRAL DOGBONE SHAFT UNIVERSAL JOINT - HUDY SPRING STEEL™
#355432 FRONT CENTRAL DOGBONE DRIVE SHAFT 85MM - HUDY SPRING STEEL™

OPTION  **XRAY BALL-BEARINGS**

#	Size	Lubricant	Material	Status
#930816	8x16x5	GREASE	STEEL	INCLUDED
#930817	8x16x5	OIL	STEEL	OPTION



BAG
02

- | | | | |
|--------|---|--------|---|
| 352006 | DIFF BULKHEAD BLOCK SET FRONT/REAR | 901504 | HEX SCREW SB M5x4 (10) |
| 355114 | BEVEL DRIVE GEAR 14T | 908312 | HEX SCREW SOCKET HEAD CAP SCH M3x12 (10) |
| 355236 | CVD DRIVE SHAFT COUPLING - HUDY SPRING STEEL™ | 930816 | BALL-BEARING 8x16x5 STEEL SEALED - GREASE (2) |
| 355414 | CENTRAL CVD SHAFT UNIVERSAL JOINT - HUDY SPRING STEEL™ | 980314 | PIN 3x14 (10) |
| 355427 | FRONT CENTRAL CVD DRIVE SHAFT 85MM - HUDY SPRING STEEL™ | 355005 | DIFFERENTIAL 46T - V2 - SET |
| 355471 | DRIVE SHAFT LOCKING RING (2) | | |
| 355472 | DRIVE SHAFT BOOT (2) | | |

980314
P 3x14

5  **OIL**
Apply oil from inside to prevent breakage of the rubber boot.

85mm - SHORT CVD DRIVE SHAFT

Graphite Grease (HUDY #106210) 

NOTE ORIENTATION 

The ring can be assembled by hand, but for easy disassembly we recommend using snap ring pliers (HUDY #189040).

STEP 4 DETAIL

TL 

PIN 

DETAIL 

TOP 

BEFORE inserting the clip on the central CVD shaft joint, apply a small amount of threadlock on the area where the clip goes.

AFTER inserting the clip on the central CVD shaft joint, turn the clip so that the slot is 90° from the pin. This will prevent the pin from opening the clip.

2. FRONT TRANSMISSION



901504
SB M5x4

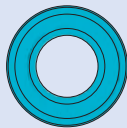

930816
BB 8x16x5



TIP
Follow the TECH TIP on page 5 for drive shaft pin servicing.

Push joint against gear to remove gap. Tighten setscrew onto gear flat spot.

STEP 5 DETAIL

XRAY BALL-BEARINGS				
OPTION	#930816	8x16x5	GREASE	STEEL INCLUDED
	#930817	8x16x5	OIL	STEEL OPTION

Use HUDY Ball-Bearing Grease

- #106220 - STANDARD
- #106221 - BLUE
- #106222 - RED



908312
SCH M3x12

! During assembly, there is no need to check gear mesh or diff play. In particular, do not check gear mesh and diff play when the differential is installed only in the gear box without the suspension holders and without being mounted to the chassis. All parts have specifically designed play, and only when the car is fully assembled will it have the proper amount of play where necessary. Only once you build the entire car, then you can check for free movement of all rotational parts and drivetrain as well as a free non-binding operation of suspension parts.

FRONT DIFF
7.000cSi

Graphite Grease (HUDY #106210)

FRONT

NOTE DIFF ORIENTATION

! NOTE DIFF ORIENTATION

Cut on both front and rear bulkhead blocks.

2. REAR TRANSMISSION

OPTION #355415 CENTRAL DOGBONE SHAFT UNIVERSAL JOINT - HUDY SPRING STEEL™ +
#355632 FRONT CENTRAL DOGBONE DRIVE SHAFT 116MM - HUDY SPRING STEEL™

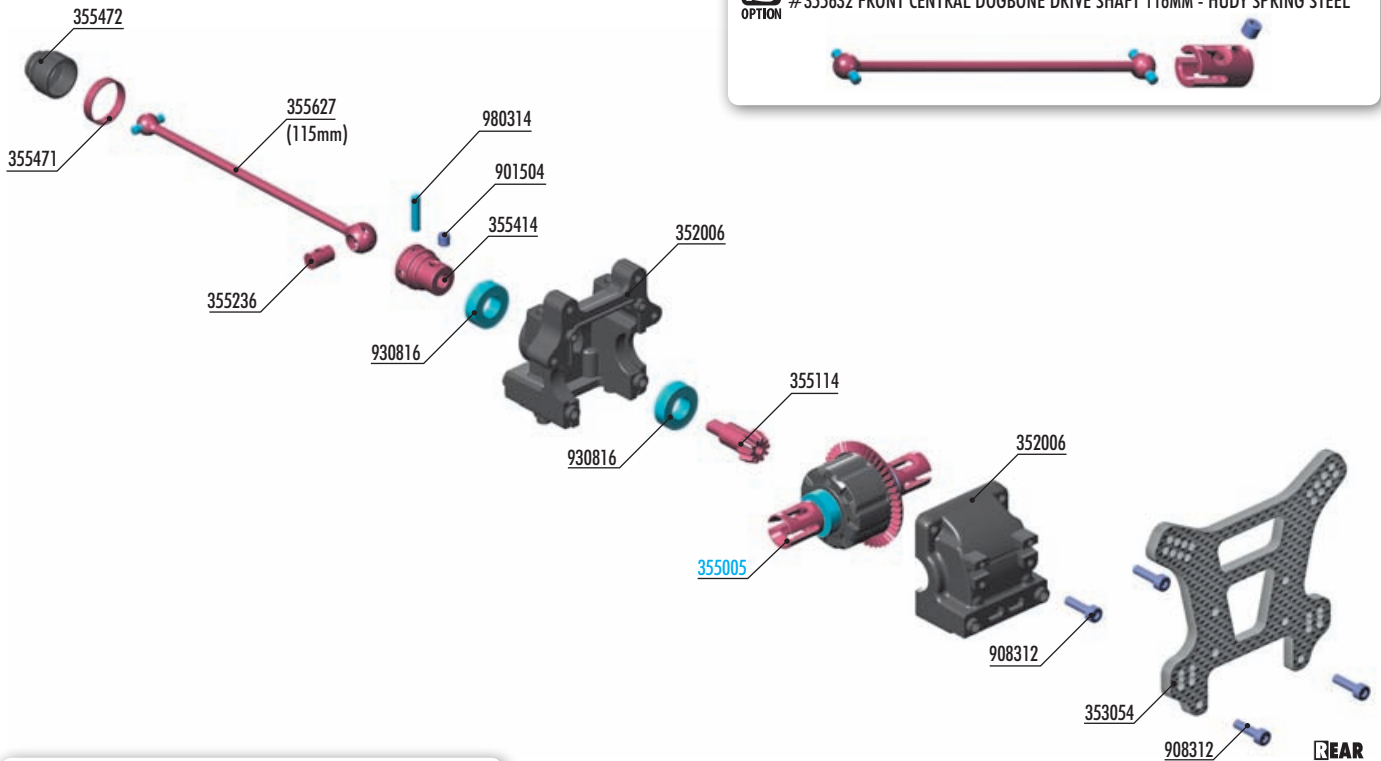

XRAY BALL-BEARINGS

OPTION	Part No.	Size	Lubricant	Material	Status
	#930816	8x16x5	GREASE	STEEL	INCLUDED
	#930817	8x16x5	OIL	STEEL	OPTION



BAG

02

- | | | | |
|--------|---|--------|--|
| 352006 | DIFF BULKHEAD BLOCK SET FRONT/REAR | 355472 | DRIVE SHAFT BOOT (2) |
| 353054 | GRAPHITE REAR SHOCK TOWER 4MM | 901504 | HEX SCREW SB M5x4 (10) |
| 355114 | BEVEL DRIVE GEAR 14T | 908312 | HEX SCREW SOCKET HEAD CAP SCH M3x12 (10) |
| 355236 | CVD DRIVE SHAFT COUPLING - HUDY SPRING STEEL™ | 930816 | BALL-BEARING 8x16x5 RUBBER SEALED - GREASE (2) |
| 355414 | CENTRAL CVD SHAFT UNIVERSAL JOINT - HUDY SPRING STEEL™ | 980314 | PIN 3x14 (10) |
| 355627 | REAR CENTRAL CVD DRIVE SHAFT 115MM - HUDY SPRING STEEL™ | 355005 | DIFFERENTIAL 46T - V2 - SET |
| 355471 | DRIVE SHAFT LOCKING RING (2) | | |

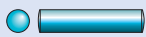

980314
P 3x14

The ring can be assembled by hand, but for easy disassembly we recommend using snap ring pliers (HUDY #189040).

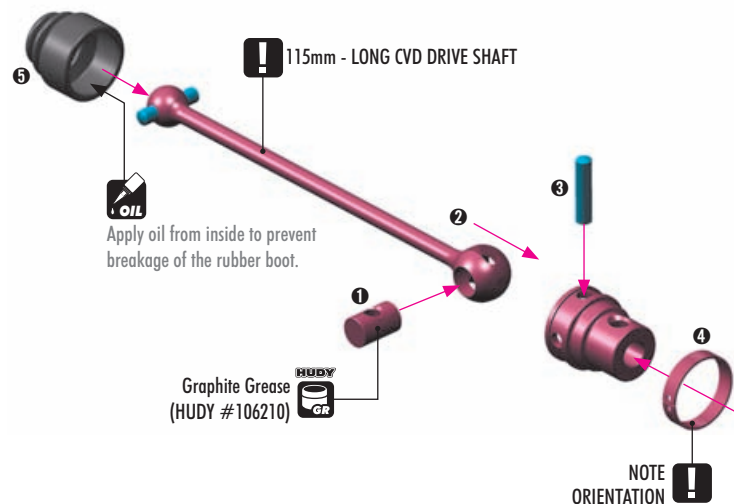
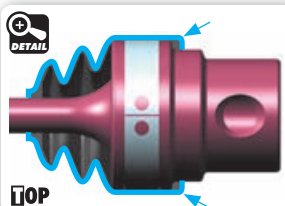
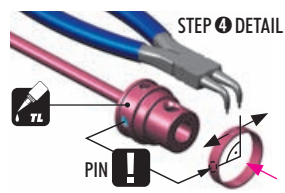

BEFORE inserting the clip on the central CVD shaft joint, apply a small amount of threadlock on the area where the clip goes.

AFTER inserting the clip on the central CVD shaft joint, turn the clip so that the slot is 90° from the pin. This will prevent the pin from opening the clip.

2. REAR TRANSMISSION



901504
SB M5x4

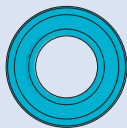

930816
BB 8x16x5



XRAY BALL-BEARINGS

OPTION	Part #	Size	Grease	Material	Included
	#930816	8x16x5	GREASE	STEEL	INCLUDED
	#930817	8x16x5	OIL	STEEL	OPTION



Use HUDY Ball-Bearing Grease

	#106220 - STANDARD
	#106221 - BLUE
	#106222 - RED

TIP
Follow the TECH TIP on page 5 for drive shaft pin servicing.

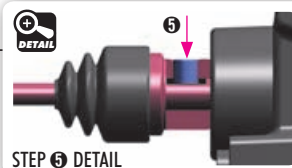

Push joint against gear to remove gap. Tighten setscrew onto gear flat spot.

STEP 6 DETAIL

! During assembly, there is no need to check gear mesh or diff play. In particular, do not check gear mesh and diff play when the differential is installed only in the gear box without the suspension holders and without being mounted to the chassis. All parts have specifically designed play, and only when the car is fully assembled will it have the proper amount of play where necessary. Only once you build the entire car, then you can check for free movement of all rotational parts and drivetrain as well as a free non-binding operation of suspension parts.



908312
SCH M3x12

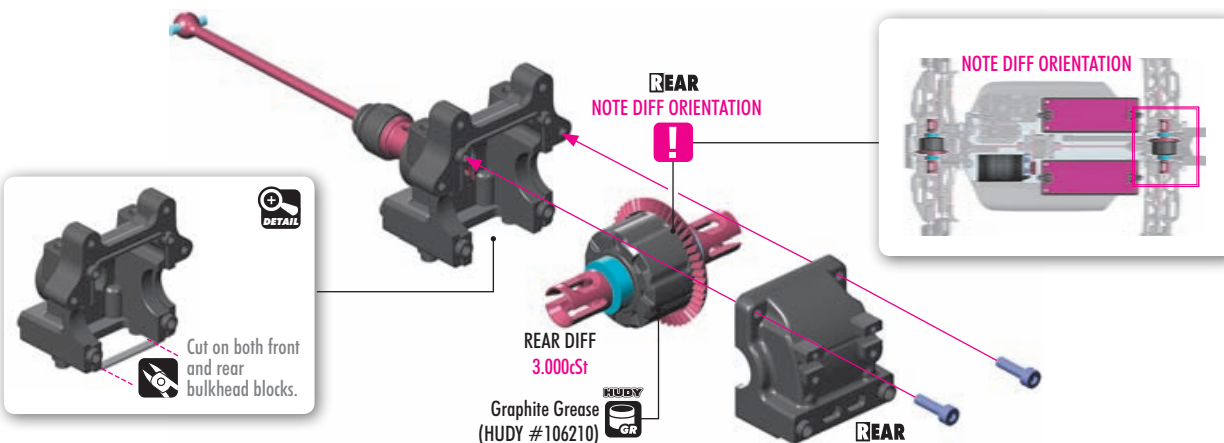

908312
SCH M3x12

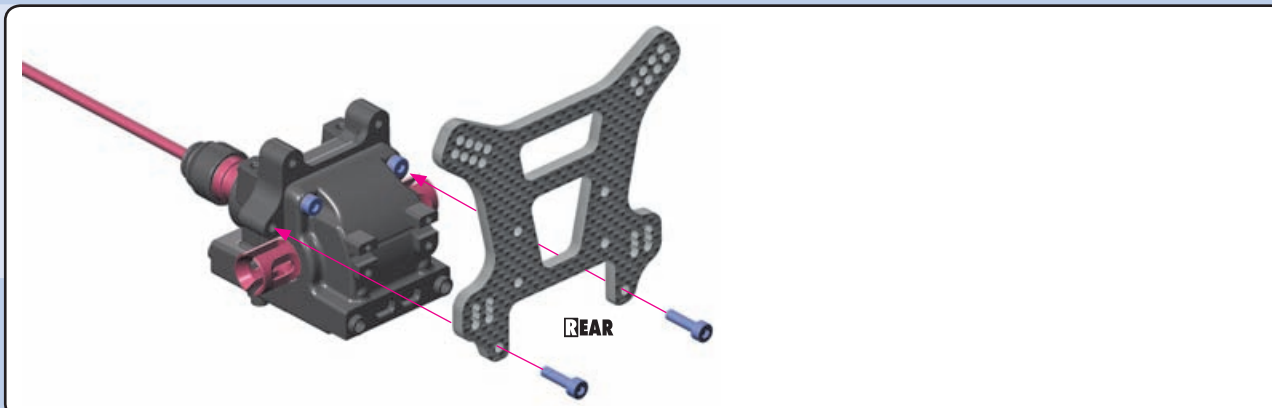

3. REAR SUSPENSION

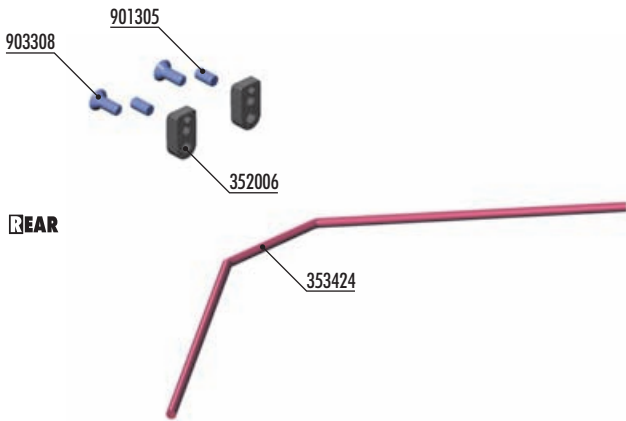

REAR

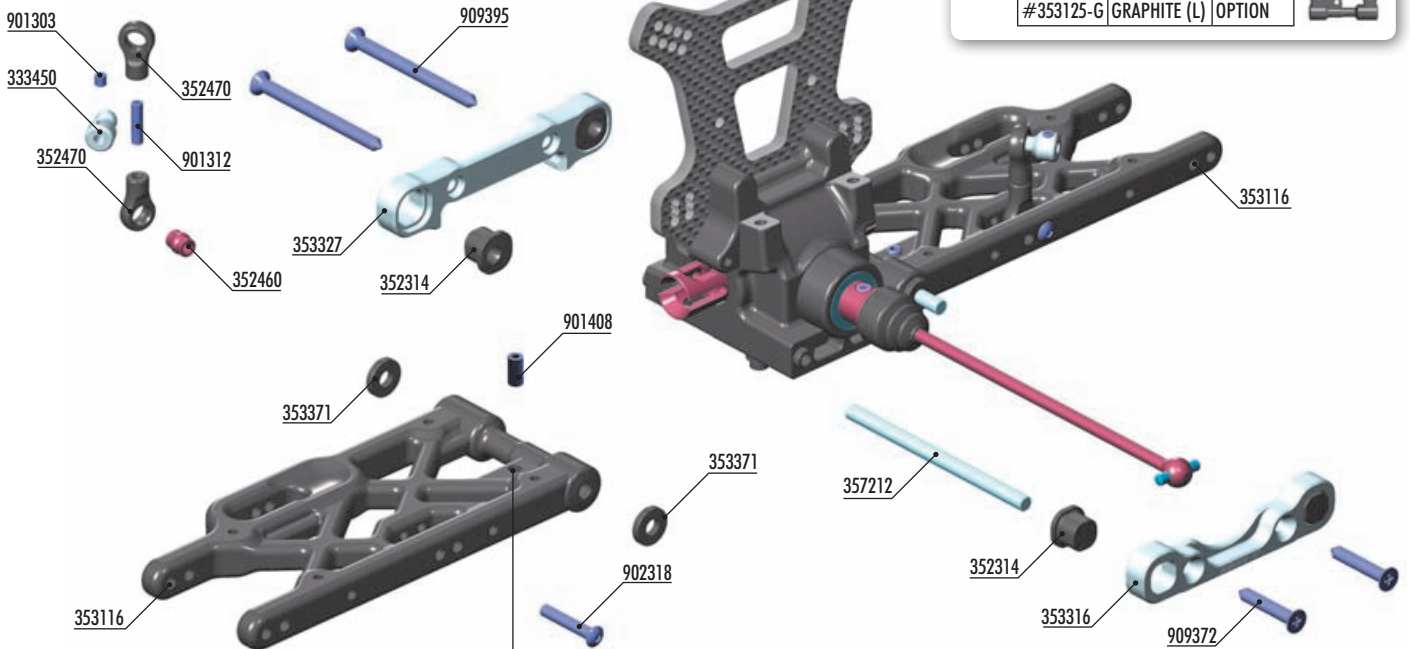

#902407
HEX SCREW SH M4x7 WITH HEX FROM BOTTOM (4)



#333451
ALU ANTI-ROLL BAR PIVOT BALL 5.8 MM - SWISS 7075 T6 - HARDCOATED (2)



SHORT - REAR SUSPENSION ARMS

#353113	RIGHT	OPTION
#353123	LEFT	OPTION
+ SUSPENSION HOLDERS		
#353317	FRONT (RF)	OPTION
#353325	REAR (RR)	OPTION



FLAT - REAR SUSPENSION ARMS

#353115	MEDIUM	OPTION
#353116	HARD	INCLUDED
#353116-XH	X-HARD	OPTION
#353116-G	GRAPHITE	OPTION



LSM - REAR SUSPENSION ARMS

#353124-H	HARD (R)	OPTION
#353125-H	HARD (L)	OPTION
#353124-G	GRAPHITE (R)	OPTION
#353125-G	GRAPHITE (L)	OPTION



REAR ANTI-ROLL BARS

#353418	ø1.8mm	OPTION
#353420	ø2.0mm	OPTION
#353422	ø2.2mm	OPTION
#353424	ø2.4mm	INCLUDED
#353425	ø2.5mm	OPTION
#353426	ø2.6mm	OPTION
#353428	ø2.8mm	OPTION
#353430	ø3.0mm	OPTION
#353432	ø3.2mm	OPTION

BAG

03

- 333450 ANTI-ROLL BAR BALL JOINT 5.8 MM (2)
- 352006 DIFF BULKHEAD BLOCK SET FRONT/REAR
- 352314 COMPOSITE ECCENTRIC BUSHINGS - V2 (2)
- 352460 PIVOT BALL 5.8 (10)
- 352470 BALL JOINT 5.8 (8)
- 353116 COMPOSITE REAR LOWER SUSPENSION ARM - HARD
- 353316 ALU REAR LOWER SUSP. HOLDER - FRONT - SQUARE ADJ. ROLL CENTER
- 353327 ALU REAR LOWER SUSP. HOLDER - REAR - SQUARE ADJ. ROLL CENTER
- 353371 SET OF COMPOSITE LOWER ARM SHIMS
- 353424 REAR ANTI-ROLL BAR 2.4MM
- 357212 LOWER INNER PIVOT PIN F+R (2)

- 901303 HEX SCREW SB M3x3 (10)
- 901305 HEX SCREW SB M3x5 (10)
- 901312 HEX SCREW SB M3x12 (10)
- 901408 HEX SCREW SB M4x8 (10)
- 902318 HEX SCREW SH M3x18 (10)
- 903308 HEX SCREW SFH M3x8 (10)
- 909372 SCREW PHILLIPS SS 3.5x22 (10)
- 909395 SCREW PHILLIPS SS 3.5x45 (10)

3. REAR SUSPENSION



353371
SHIM 4x10x2



901408
SB M4x8



909372
SS 3.5x22



909395
SS 3.5x45

**MEDIUM
SUSPENSION ARMS**

RR
1° 0.5°

RF
1° 0.5°

Do not use INNER positions.

**HARD
SUSPENSION ARMS**

RR
1° 0.5°

RF
1° 0.5°

All positions are available.

**X-HARD / GRAPHITE
SUSPENSION ARMS**

RR
1° 0.5°

RF
1° 0.5°

Do not use OUTER positions.

ECCENTRIC BUSHINGS HAVE TWO DIFFERENT OFFSETS FROM THE CENTER.



All possible mounting alternatives of eccentric bushings.

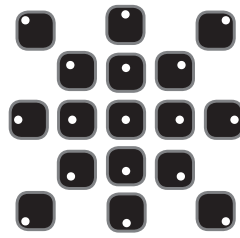

SET-UP BOOK
TOE-IN
ANTI-SQUAT
ROLL CENTER
DOWNSTOP
WHEELBASE
TRACK WIDTH

The XRAY rear alu lower suspension holders provide even greater range of adjustment for the rear suspension. Using different combinations of eccentric bushings, fine adjustment of rear anti-squat, rear toe-in, rear roll center, and rear track-width can be obtained. For more information about the influence of rear anti-squat, rear toe-in, rear roll center and rear track width on car handling, please refer to HUDY Off-Road Set-up Book (#209099).

ANTI-SQUAT		
RR	RF	(°)
0	0	= 3°
0	0.5	= 4°
0	1	= 2°
0.5	0	= 4°
0.5	0.5	= 3°
0.5	1	= 5°
1	0	= 2°
1	0.5	= 3°
1	1	= 1°

ROLL CENTER		
RR	RF	(mm)
0	0	= 0mm
0	1	= 1mm
0	-1	= -1mm

TRACK-WIDTH		
RR	RF	(mm)
0	0	= 308
0	1	= 306
0	-1	= 310

TOE-IN		
RR	RF	(°)
0	0	= 3°
0	1	= 4°
0	-1	= 2°
1	0	= 2°
1	1	= 3°
1	-1	= 1°
-1	0	= 4°
-1	1	= 5°
-1	-1	= 3°

The tables describe the amounts of rear anti-squat, rear toe-in, rear track-width change depending on the combinations of eccentric bushings used with 0 and 1mm, 1° offset. The 0.5mm, 0.5° represents the half change.

Anti-Squat Example:

0(RR) - 0 (RF) = 3°

0(RR) - 0.5 (RF) = 3.5°

0(RR) - 1 (RF) = 4°

3. REAR SUSPENSION



2x
L=R

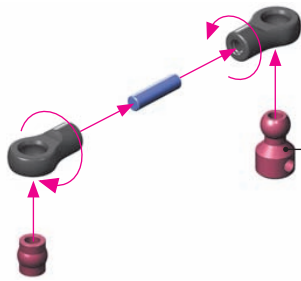

TIP Install the pivot balls with Professional Multi-Tool (HUDY #183011).

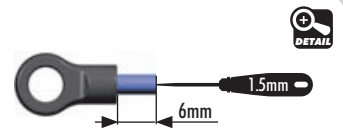

L=R

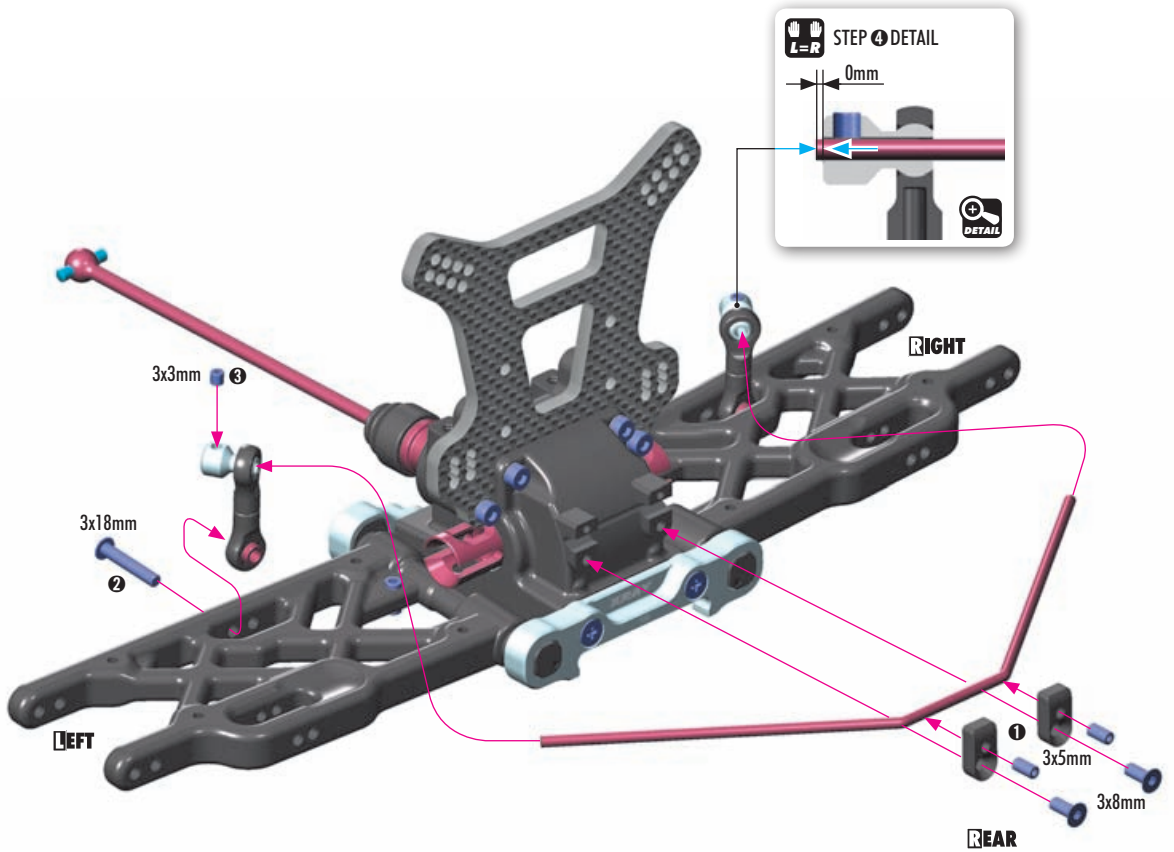

SET-UP BOOK
ANTI-ROLL BAR

INITIAL SETTING

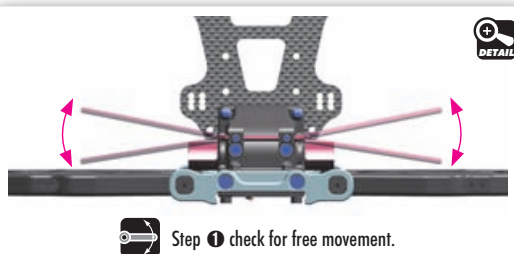

Loosen the 3x5 setscrew if the anti-roll bar does not turn freely.

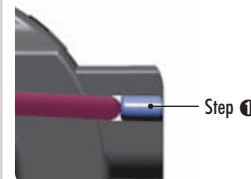

OPTION	REAR ANTI-ROLL BARS	
#353418	ø1.8mm	OPTION
#353420	ø2.0mm	OPTION
#353422	ø2.2mm	OPTION
#353424	ø2.4mm	INCLUDED
#353425	ø2.5mm	OPTION
#353426	ø2.6mm	OPTION
#353428	ø2.8mm	OPTION
#353430	ø3.0mm	OPTION
#353432	ø3.2mm	OPTION

4. REAR SUSPENSION

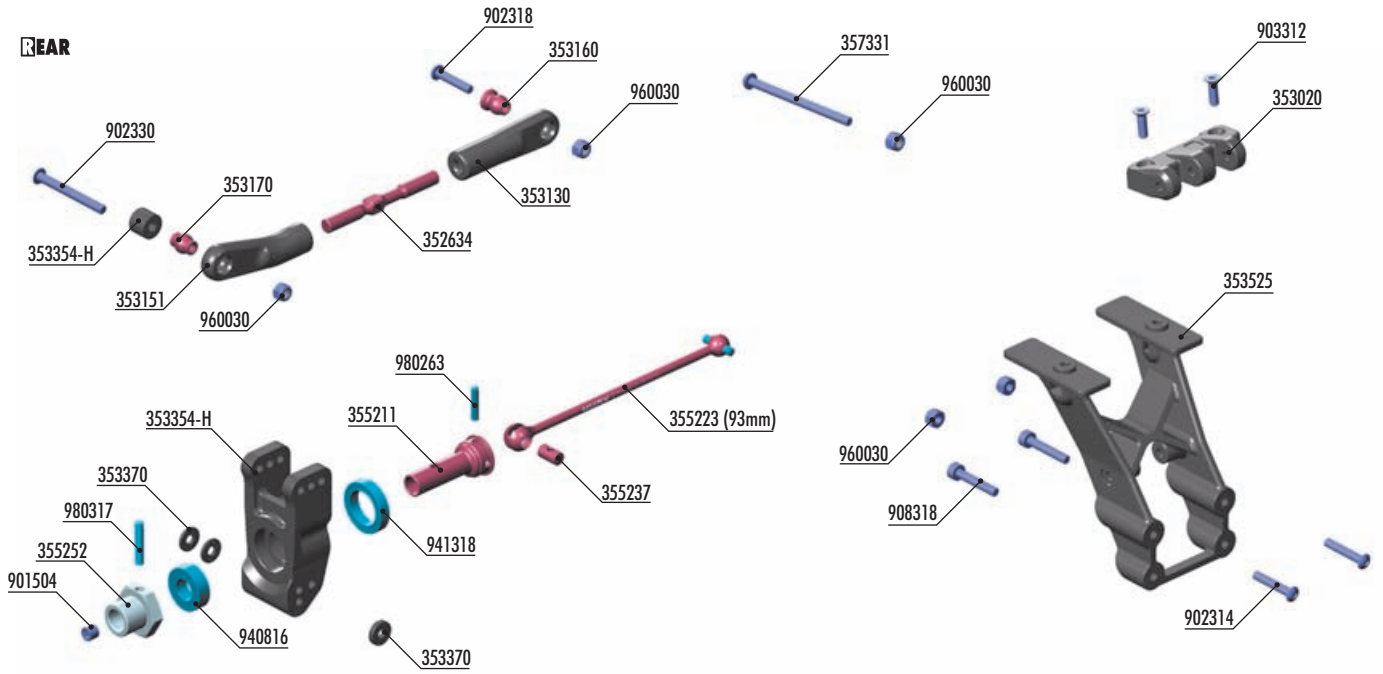

#355215
OPTION CVD ADJUSTABLE DRIVE AXLE - HUDY SPRING STEEL™

#355215
OPTION CVD ADJUSTABLE DRIVE AXLE - HUDY SPRING STEEL™

REAR UPRIGHTS		
#353354	MEDIUM	OPTION
#353354-H	HARD	INCLUDED
#353354-G	GRAPHITE	OPTION
#350908	ALU - SET	OPTION

#355215
OPTION CVD ADJUSTABLE DRIVE AXLE - HUDY SPRING STEEL™

XRAY BALL-BEARINGS				
#930816	8x16x5	GREASE	STEEL	OPTION
#940816	8x16x5	GREASE	RUBBER	INCLUDED
#931318	13x19x4	GREASE	STEEL	OPTION
#941318	13x19x4	GREASE	RUBBER	INCLUDED
#930817	8x16x5	OIL	STEEL	OPTION
#940817	8x16x5	OIL	RUBBER	OPTION
#931319	13x19x4	OIL	STEEL	OPTION
#941319	13x19x4	OIL	RUBBER	OPTION

#350908
OPTION XRAY XB8 ALU REAR UPRIGHTS - SET

BAG
04

- 352634 ADJ. TURNBUCKLE M5 L/R 50 MM - HUDY SPRING STEEL™ (2)
- 353020 COMPOSITE REAR BRACE HOLDER
- 353130 REAR UPPER INNER CAMBER LINK BALL JOINT (2)
- 353151 RELIEF REAR UPPER OUTER CAMBER LINK BALL JOINT (2)
- 353160 MOUNTING BALL 6.8 (4)
- 353170 PIVOT BALL 6.8 (4)
- 353354-H COMPOSITE REAR UPRIGHT - HARD
- 353370 SET OF COMPOSITE REAR HUB CARRIER SHIMS
- 353525 COMPOSITE REAR WING HOLDER FOR FRONTWARD WING POSITION
- 355211 CVD DRIVE AXLE - HUDY SPRING STEEL™
- 355223 CVD UNIVERSAL DRIVE SHAFT 93MM - HUDY SPRING STEEL™
- 355237 CVD DRIVE SHAFT COUPLING - HUDY SPRING STEEL™
- 355252 ALU WHEEL AXLE OFFSET "+2MM"- BLACK COATED (2)

- 357331 REAR LOWER OUTER PIVOT PIN SCREW 3MM (2)
- 901504 HEX SCREW SB M5x4 (10)
- 902314 HEX SCREW SH M3x14 (10)
- 902318 HEX SCREW SH M3x18 (10)
- 902330 HEX SCREW SH M3x30 (10)
- 903312 HEX SCREW SFH M3x12 (10)
- 908318 HEX SCREW SOCKET HEAD CAP SCH M3x18 (10)
- 940816 BALL-BEARING 8x16x5 RUBBER SEALED - GREASE (2)
- 941318 BALL-BEARING 13x19x4 RUBBER SEALED - GREASE (2)
- 960030 NUT M3 (10)
- 980263 PIN 2.5x13 (10)
- 980317 PIN 3x17 (10)

4. REAR SUSPENSION

901504
SB M5x4

940816
BB 8x16x5

941318
BB 13x19x4

980263
P 2.5x13

980317
P 3x17

2x **L=R**

NOTE ORIENTATION

93mm
- SHORT CVD DRIVE SHAFT

TIP To tighten the setscrew you can also use the HUDY 17mm Wheel Nut Tool #107570.

TIP Follow the TECH TIP on page 5 for drive shaft pin servicing.

Graphite Grease
(HUDY #106210)

Use HUDY Ball-Bearing Grease
 #106220 - STANDARD
 #106221 - BLUE
 #106222 - RED

REAR UPRIGHTS

#353354	MEDIUM	OPTION
#353354-H	HARD	INCLUDED
#353354-G	GRAPHITE	OPTION
#350908	ALU - SET	OPTION

OFFSET WHEEL AXLES

#355250	0mm	OPTION
#355251	+1mm	OPTION
#355252	+2mm	INCLUDED

#352515
CVD ADJUSTABLE DRIVE AXLE - HUDY SPRING STEEL™

Drive shaft position
4 | 3 | 2 | 1

353370
SHIM 3x9x1

353370
SHIM 3x9x2

960030
N M3

2x **L=R**

TIP Ensure that the rear upright moves freely. If it does not move freely, use sandpaper to thin both wheelbase adjustment shims.

REAR **LEFT**

Shims for wheelbase adjustment
2 + 1 + 1mm

RIGHT Do not overtighten the self-locking nut. Overtightening may result in suspension binding.

TIP **L=R** **ARM REAMER** (HUDY #107643)
If the rear upright does not move freely, use a HUDY Arm Reamer to resize the hole.

INITIAL SETTING

Check for free movement.

2x **L=R**

TIP Install the pivot balls with Professional Multi-Tool (HUDY #183011).

NOTE ORIENTATION

NOTE ORIENTATION

LEFT THREAD **RIGHT THREAD**

LEFT THREAD **RIGHT THREAD**

LEFT **RIGHT**

Oil **RIGHT THREAD**

Oil **LEFT THREAD**

26.5mm

26.5mm

RIGHT THREAD **LEFT THREAD**

LEFT **RIGHT**

DETAIL Use tools to tighten as shown.

Special Tool for all turnbuckles & nuts (HUDY #181090) or Turnbuckle Wrench 5mm (HUDY #181050).

SET-UP BOOK
CAMBER

4. REAR SUSPENSION

2x **L=R**

353354-H
SHIM 3x9x7

902318
SH M3x18

902330
SH M3x30

960030
N M3

NOTE ORIENTATION

7mm

3x18mm

3x30mm

REAR

LEFT

RIGHT

L=R

INITIAL SETTING

DETAIL

INITIAL SETTING

DETAIL

903312
SFH M3x12

REAR

902314
SH M3x14

908318
SCH M3x18

960030
N M3

REAR

5. FRONT SUSPENSION

FRONT LOWER SUSP. ARMS			
#352120	SOFT	OPTION	
#352120-M	MEDIUM	INCLUDED	
#352120-G	GRAPHITE	OPTION	

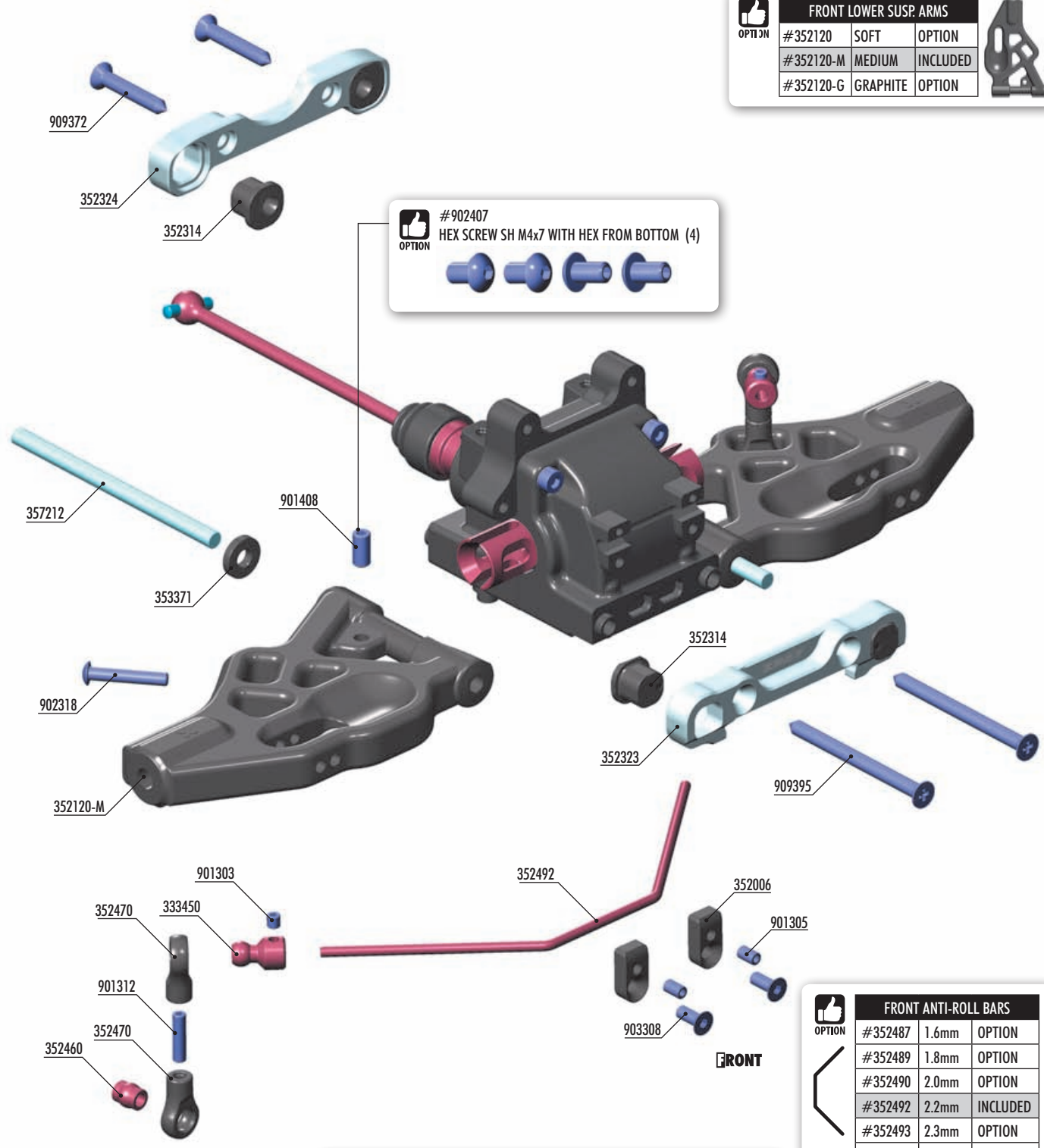

#902407
HEX SCREW SH M4x7 WITH HEX FROM BOTTOM (4)

OPTION



FRONT ANTI-ROLL BARS		
#352487	1.6mm	OPTION
#352489	1.8mm	OPTION
#352490	2.0mm	OPTION
#352492	2.2mm	INCLUDED
#352493	2.3mm	OPTION
#352494	2.4mm	OPTION
#352495	2.5mm	OPTION
#352496	2.6mm	OPTION
#352498	2.8mm	OPTION

#333451
ALU ANTI-ROLL BAR PIVOT BALL 5.8 MM - SWISS 7075 T6 - HARDCOATED (2)

OPTION



BAG
05

- | | | | |
|----------|---|--------|-------------------------------|
| 333450 | ANTI-ROLL BAR BALL JOINT 5.8 MM (2) | 357212 | LOWER INNER PIVOT PIN F+R (2) |
| 352006 | DIFF BULKHEAD BLOCK SET FRONT/REAR | 901303 | HEX SCREW SB M3x3 (10) |
| 352120-M | COMPOSITE FRONT LOWER SUSPENSION ARM - MEDIUM | 901305 | HEX SCREW SB M3x5 (10) |
| 352314 | COMPOSITE SQUARE ADJ. ROLL CENTER BUSHINGS - V2 (2) | 901312 | HEX SCREW SB M3x12 (10) |
| 352323 | ALU FRONT LOWER SUSP. HOLDER - FRONT - SQUARE ADJ. ROLL CENTER - V2 | 901408 | HEX SCREW SB M4x8 (10) |
| 352324 | ALU FRONT LOWER SUSP. HOLDER - REAR - SQUARE ADJ. ROLL CENTER - V2 | 902318 | HEX SCREW SH M3x18 (10) |
| 352460 | PIVOT BALL 5.8 (10) | 903308 | HEX SCREW SFH M3x8 (10) |
| 352470 | BALL JOINT 5.8 (8) | 909372 | SCREW PHILLIPS SS 3.5x22 (10) |
| 352492 | FRONT ANTI-ROLL BAR 2.4MM | 909395 | SCREW PHILLIPS SS 3.5x45 (10) |
| 353371 | SET OF COMPOSITE LOWER ARM SHIMS | | |

5. FRONT SUSPENSION

10

353371
SHIM 4x10x2



901408
SB M4x8



909372
SS 3.5x22



909395
SS 3.5x45

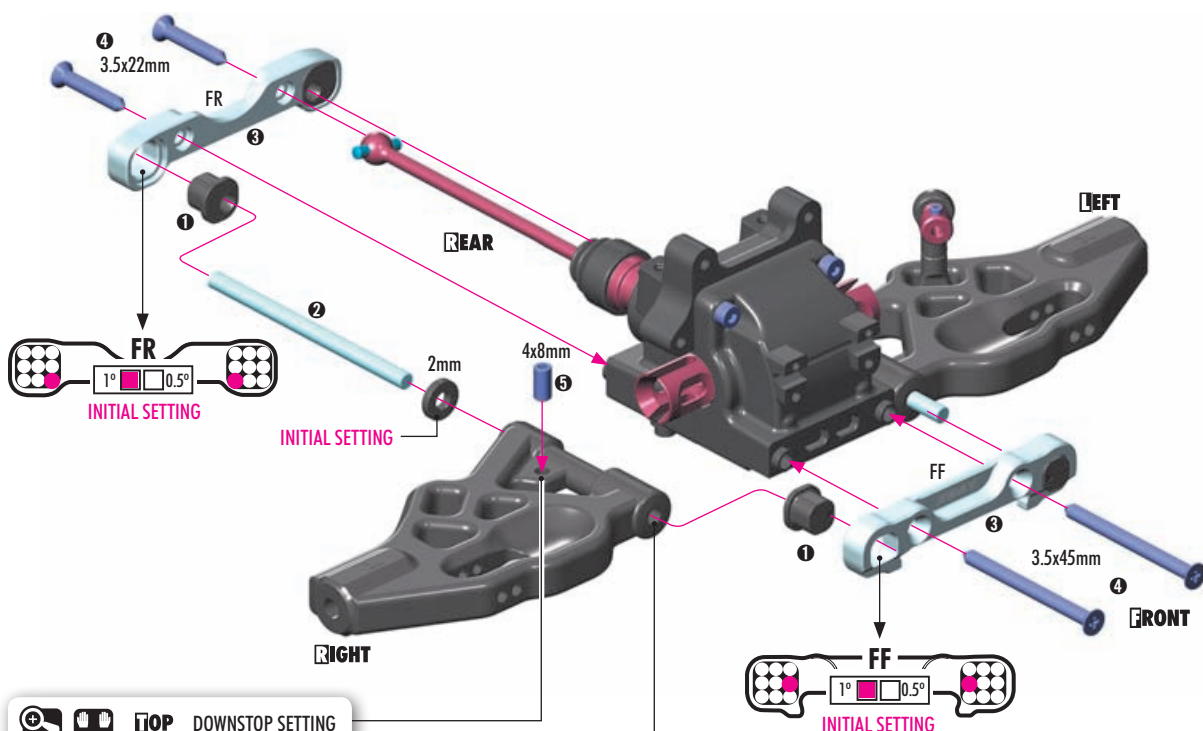

TOP DOWNSTOP SETTING
DETAIL **L=R**

BOTTOM 0.0mm

#902407
OPTION

Downstop screw for fine tuning.

TIP **L=R** **DETAIL**

If the suspension arms do not move freely, use a HUDY Arm Reamer to resize the holes.

(HUDY #107644)
ARM REAMER

All possible mounting alternatives of eccentric bushings.

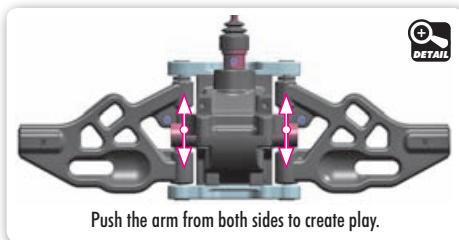
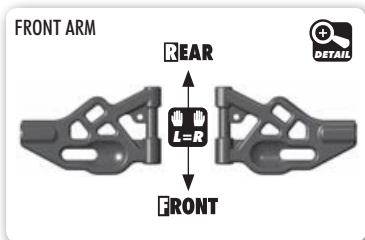

Eccentric bushings have two different offsets from the center.

- Middle position = 0.5 mm or 0.5° from center.
- Outer position = 1 mm or 1° from center.

The XRAY alu front lower suspension holders provide even greater range of adjustment for the front suspension. Using different combinations of eccentric bushings, fine adjustment of front kick-up, roll center, and front track-width can be obtained. For more information about the influence of kick-up, front track-width, and roll centers on car handling, please refer to HUDY Off-Road Set-up Book (#209099).

TRACK-WIDTH		
FF	FR	(mm)
0	0	=308
0.5	0.5	=306
1	1	=310*

ROLL CENTER		
FF	FR	(mm)
0	0	=1
0.5	0.5	=0
1	1	=-1

The tables below describe the amounts of kick-up, front track-width change depending on the combinations of eccentric bushings used with 0 and 1mm, 1° offset. The 0.5mm, 0.5° represents the half change.

* Not recommended to use this setting.

SET-UP BOOK
KICK UP
ROLL CENTER DOWNSTOP
WHEELBASE
TRACK WIDTH

5. FRONT SUSPENSION



901312
SB M3x12

2x L=R

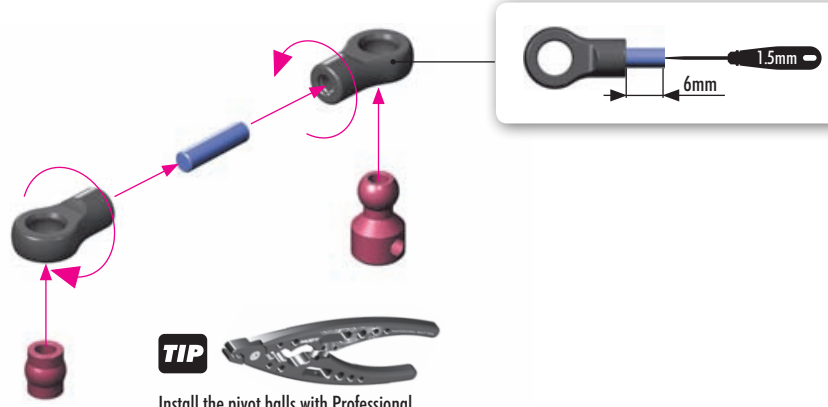

TIP Install the pivot balls with Professional Multi Tool (HUDY #183011).



901303
SB M3x3



901305
SB M3x5



902318
SH M3x18



903308
SFH M3x8

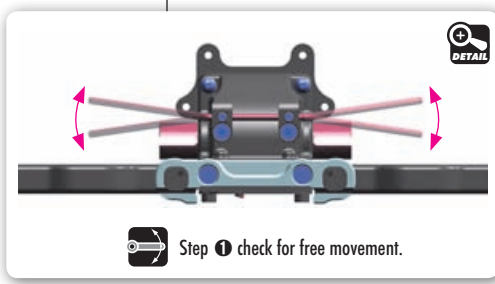
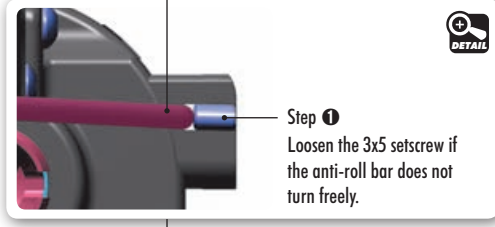
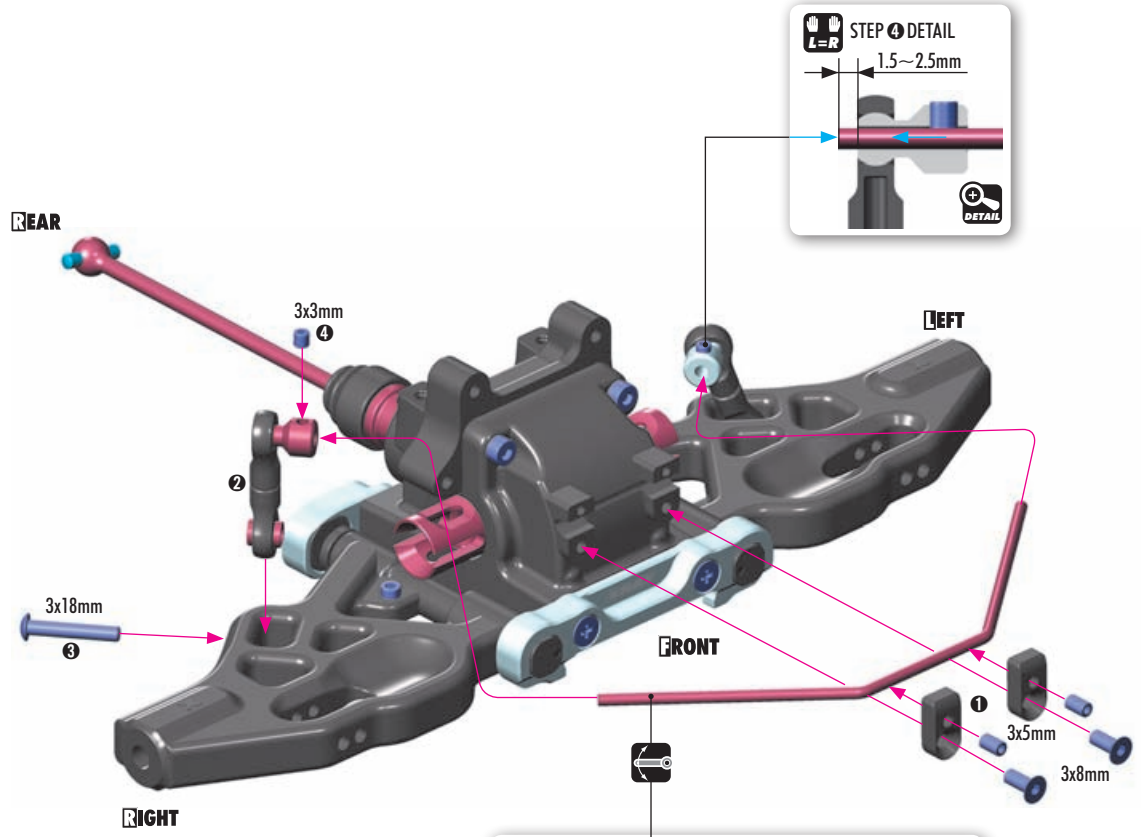

FRONT ANTI-ROLL BARS			
OPTION	#352487	1.6mm	OPTION
	#352489	1.8mm	OPTION
	#352490	2.0mm	OPTION
	#352492	2.2mm	INCLUDED
	#352493	2.3mm	OPTION
	#352494	2.4mm	OPTION
	#352495	2.5mm	OPTION
	#352496	2.6mm	OPTION
	#352498	2.8mm	OPTION

SET-UP BOOK
ANTI-ROLL BAR

6. FRONT SUSPENSION

#350907
C-HUB FRONT SUSPENSION CONVERSION SET



#357253
BRASS ADJUSTING NUT M15x1



FRONT UPPER SUSP. ARMS

#352133	SOFT	OPTION
#352133-M	MEDIUM	INCLUDED
#352133-G	GRAPHITE	OPTION



OFFSET WHEEL AXLES

#35250	0mm	OPTION
#35251	+1mm	INCLUDED
#35252	+2mm	OPTION



STEERING BLOCKS

#352244	MEDIUM	OPTION
#352244-H	HARD	INCLUDED
#352244-G	GRAPHITE	OPTION

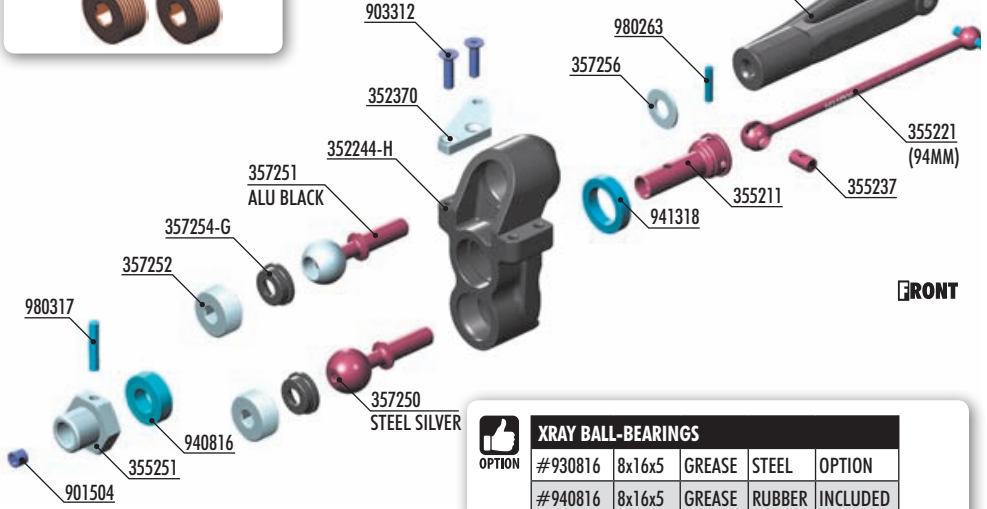
ALU STEERING PLATE

#352372	1 DOTS	OPTION
#352370	2 DOTS	INCLUDED



XRAY BALL-BEARINGS

#930816	8x16x5	GREASE	STEEL	OPTION
#940816	8x16x5	GREASE	RUBBER	INCLUDED
#931318	13x19x4	GREASE	STEEL	OPTION
#941318	13x19x4	GREASE	RUBBER	INCLUDED
#930817	8x16x5	OIL	STEEL	OPTION
#940817	8x16x5	OIL	RUBBER	OPTION
#931319	13x19x4	OIL	STEEL	OPTION
#941319	13x19x4	OIL	RUBBER	OPTION



- 352133-M FRONT UPPER ARM
- 352244-H PB STEERING BLOCK LB - HARD
- 352370 ALU STEERING PLATE - SWISS 7075 T6 (L+R)
- 355211 CVD DRIVE AXLE - HUDY SPRING STEEL™
- 355221 CVD UNIVERSAL DRIVE SHAFT 94MM - HUDY SPRING STEEL™
- 355237 CVD DRIVE SHAFT COUPLING - HUDY SPRING STEEL™
- 355251 ALU WHEEL AXLE OFFSET "+1MM" - HARD COATED (2)
- 357250 STEEL PIVOT BALL 13.7 MM (2)
- 357251 ALU PIVOT BALL 13.7 MM WITH STEEL SCREW (2)
- 357252 ALU ADJUSTING NUT M15x1 (2)
- 357254-G COMPOSITE BALL CUP 13.9 MM - GRAPHITE (2)
- 357256 ALU SHIM 6x13x1 (2)
- 901504 HEX SCREW SB M5x4 (10)
- 903312 HEX SCREW SFH M3x12 (10)
- 940816 BALL-BEARING 8x16x5 RUBBER SEALED - GREASE (2)
- 941318 BALL-BEARING 13x19x4 RUBBER SEALED - GREASE (2)
- 980263 PIN 2.5x13 (10)
- 980317 PIN 3x17 (10)

- 901504 SB M5x4
- 940816 BB 8x16x5
- 941318 BB 13x19x4
- 980263 P 2.5x13
- 980317 P 3x17

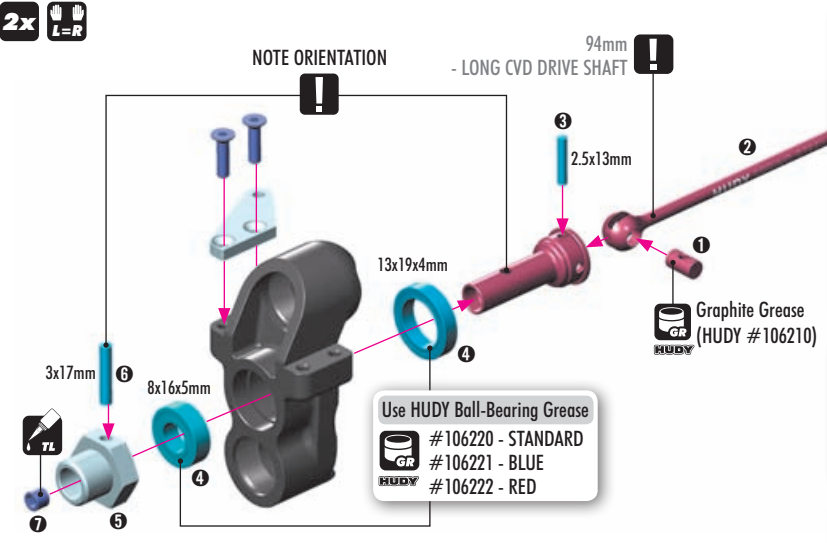

#355222
UNIVERSAL DRIVE SHAFT - HUDY SPRING STEEL™



OFFSET WHEEL AXLES

#355250	0mm	OPTION
#355251	+1mm	INCLUDED
#355252	+2mm	OPTION



STEERING BLOCKS

#352244	MEDIUM	OPTION
#352244-H	HARD	INCLUDED
#352244-G	GRAPHITE	OPTION



ALU STEERING PLATE

#352372	1 DOTS	OPTION
#352370	2 DOTS	INCLUDED

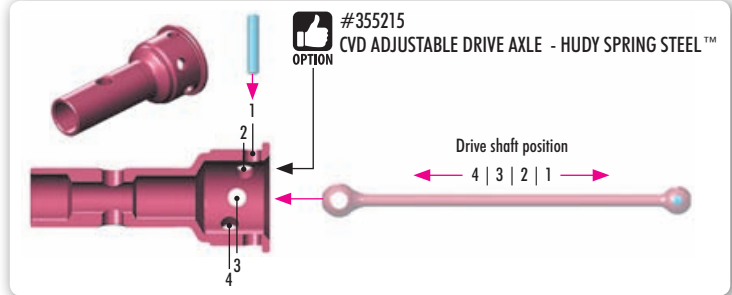
TIP To tighten the setscrew you can also use the (HUDY 17mm Wheel Nut Tool #107570).



6. FRONT SUSPENSION

2x **L=R**

! ALU pivot ball
BLACK color

! STEEL pivot ball
SILVER color

TIP Tighten hex nuts using HUDY tool #107581.

OPTION **#357253** Brass Adjusting Nut M15x1

DETAIL

PIVOT BALLS MUST MOVE FREELY
During initial assembly, tighten each hex nut until the pivot ball starts to bind, then loosen slightly. Verify that the pivot balls move freely.

357256
SHIM 6x13x1

2x **L=R**

TIP 2.5mm
HUDY Tool Allen 2.5mm

1mm

OPTION

FRONT UPPER SUSP. ARMS		
#352133	SOFT	OPTION
#352133-M	MEDIUM	INCLUDED
#352133-G	GRAPHITE	OPTION

SET-UP BOOK
CAMBER
TRACK-WIDTH

2x **L=R**

TIP 2.5mm
HUDY Tool Allen 2.5mm

RIGHT

FRONT

LEFT

SET-UP BOOK
ROLL CENTER

6. FRONT & REAR ASSEMBLY

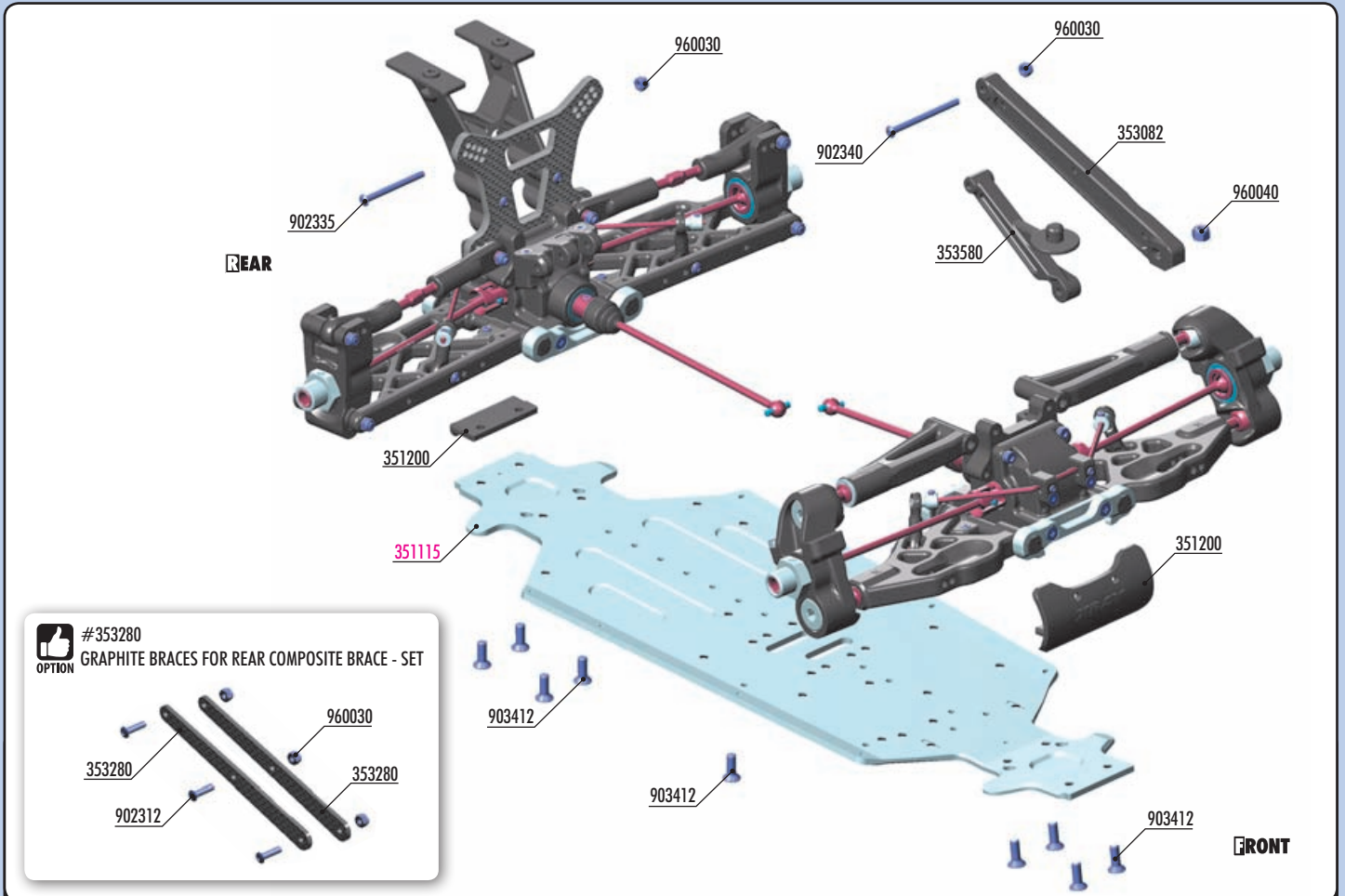

- 351200 FRONT & REAR BUMPER - V2
- 353082 COMPOSITE REAR BRACE - MEDIUM - M
- 353580 COMPOSITE WING HOLDER BRACE WITH REAR BODY POST
- 902335 HEX SCREW SH M3x35 (10)
- 902340 HEX SCREW SH M3x40 (10)

- 903412 HEX SCREW SFH M4x12 (10)
- 960030 NUT M3 (10)
- 960040 NUT M4 (10)

35115 XB8E ALU CHASSIS - SWISS 7075 T6 (3MM)



903412 SFH M4x12

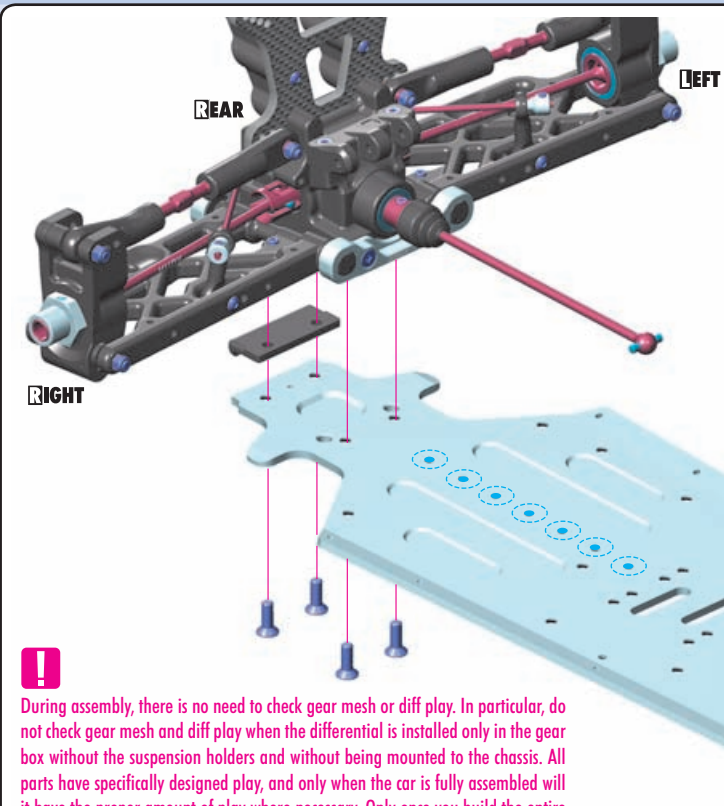

#293084 PRECISION BALANCING CHASSIS WEIGHT 10G (4)



903308 SFH M3x8

Locations for weights



During assembly, there is no need to check gear mesh or diff play. In particular, do not check gear mesh and diff play when the differential is installed only in the gear box without the suspension holders and without being mounted to the chassis. All parts have specifically designed play, and only when the car is fully assembled will it have the proper amount of play where necessary. Only once you build the entire car, then you can check for free movement of all rotational parts and drivetrain as well a free non-binding operation of suspension parts.

6. FRONT & REAR ASSEMBLY



902335
SH M3x35



960030
N M3

Push the top of the holder ① with fingers together to insert the brace with body post.

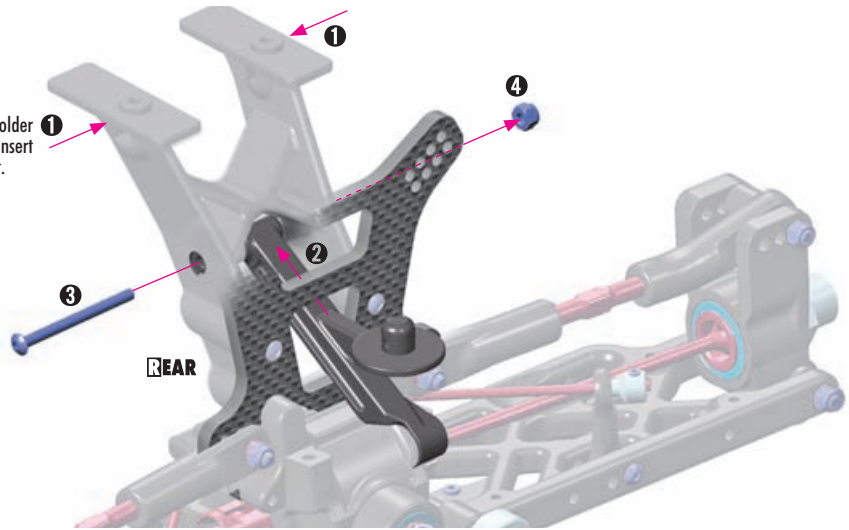

902340
SH M3x40



903412
SFH M4x12



960030
N M3



960040
N M4

REAR

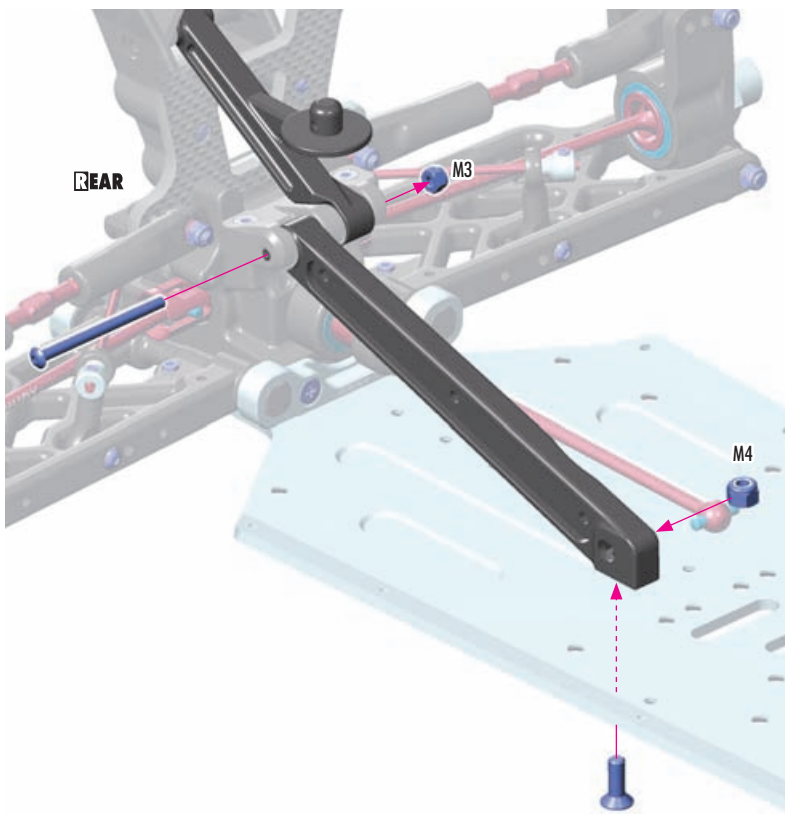

#353280
GRAPHITE BRACE SET for extra stiffness adjustment.

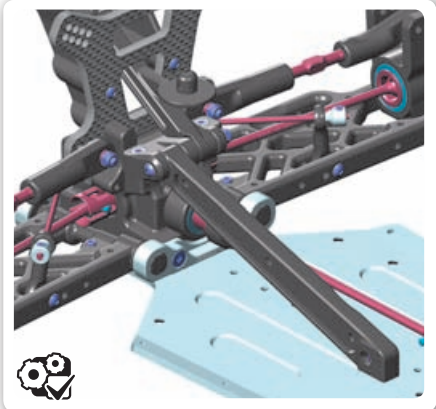

903412
SFH M4x12

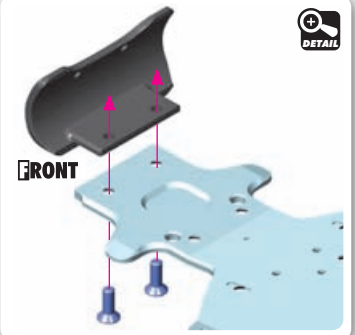
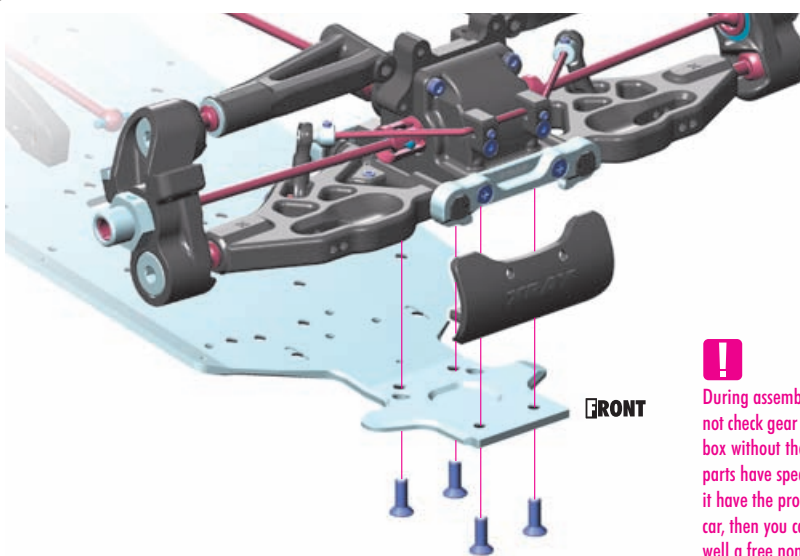

During assembly, there is no need to check gear mesh or diff play. In particular, do not check gear mesh and diff play when the differential is installed only in the gear box without the suspension holders and without being mounted to the chassis. All parts have specifically designed play, and only when the car is fully assembled will it have the proper amount of play where necessary. Only once you build the entire car, then you can check for free movement of all rotational parts and drivetrain as well as a free non-binding operation of suspension parts.

7. STEERING

#352658
OPTION BALL STUD 6.8mm WITH BACKSTOP L=6mm - M3x8 (2)

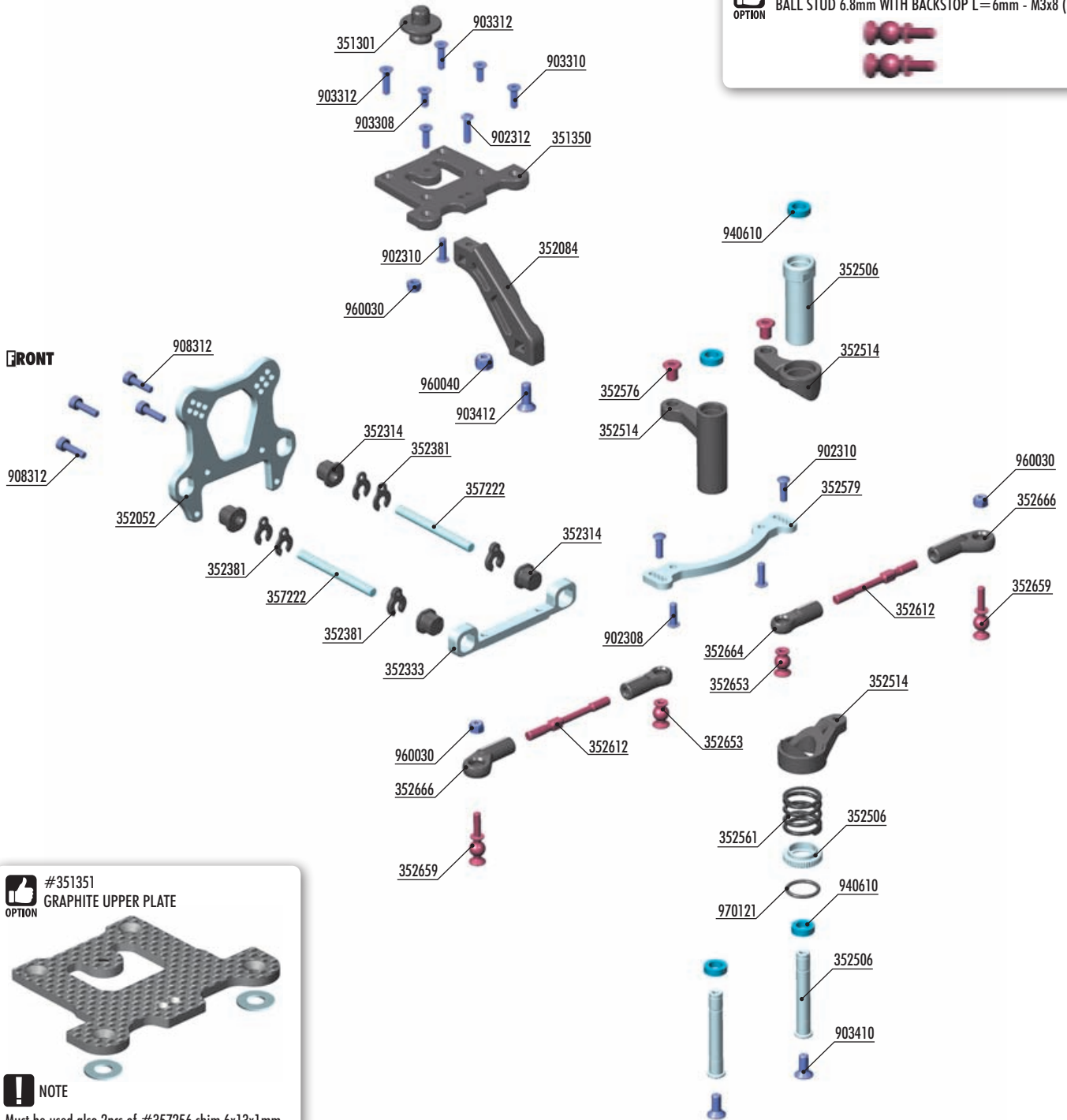
#351351
OPTION GRAPHITE UPPER PLATE

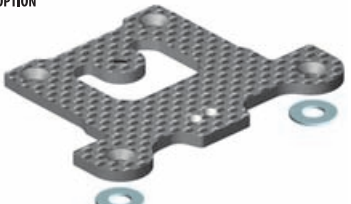

NOTE
 Must be used also 2pcs of #357256 shim 6x13x1mm.

BAG

07

- | | | | |
|--------|--|--------|---|
| 351301 | BODY POSTS | 902308 | HEX SCREW SH M3x8 (10) |
| 351350 | COMPOSITE UPPER PLATE WITH TWO BRACE POSITIONS | 902310 | HEX SCREW SH M3x10 (10) |
| 352084 | COMPOSITE FRONT BRACE | 902312 | HEX SCREW SH M3x12 (10) |
| 352052 | ALU FRONT SHOCK TOWER - CNC MACHINED 7075 T6 (4MM) | 903308 | HEX SCREW SFH M3x8 (10) |
| 352314 | COMPOSITE SQUARE ADJ. ROLL CENTER BUSHINGS - V2 (2) | 903310 | HEX SCREW SFH M3x10 (10) |
| 352333 | ALU FRONT UPPER ARM HOLDER - SWISS 7075 T6 (6MM) | 903312 | HEX SCREW SFH M3x12 (10) |
| 352381 | CASTER CLIPS (2) | 903410 | HEX SCREW SFH M4x10 (10) |
| 352506 | SERVO SAVER WITH CHASSIS LOCK & HARD SPRING - GRAPHITE - SET | 903412 | HEX SCREW SFH M4x12 (10) |
| 352514 | COMPOSITE SERVO SAVER - GRAPHITE | 908312 | HEX SCREW SOCKET HEAD CAP SCH M3x12 (10) |
| 352561 | SERVO SAVER SPRING PROGRESSIVE | 940610 | BALL-BEARING 6x10x3 RUBBER SEALED - OIL (2) |
| 352576 | STEERING PLATE BUSHING (2) | 960030 | NUT M3 (10) |
| 352579 | ALU STEERING PLATE - SWISS 7075 T6 | 960040 | NUT M4 (10) |
| 352612 | ADJ. TURNBUCKLE M4 L/R 45 MM - HUDY SPRING STEEL™ (2) | 970121 | O-RING 12.1 x 1.6 (10) |
| 352653 | BALL STUD 6.8MM WITH BACKSTOP - M3 (2) | | |
| 352659 | BALL STUD 6.8MM WITH BACKSTOP L=6MM - M3x11 (2) | | |
| 352664 | COMPOSITE STEERING BALL JOINT 6.8MM - V3 (2) | | |
| 352666 | COMPOSITE RELIEF STEERING BALL JOINT 6.8MM (2) | | |
| 357222 | FRONT UPPER PIVOT PIN 4x45 (2) | | |

7. STEERING



970121
O 12.1x1.6

SET-UP BOOK
SERVO SAVER

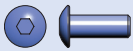
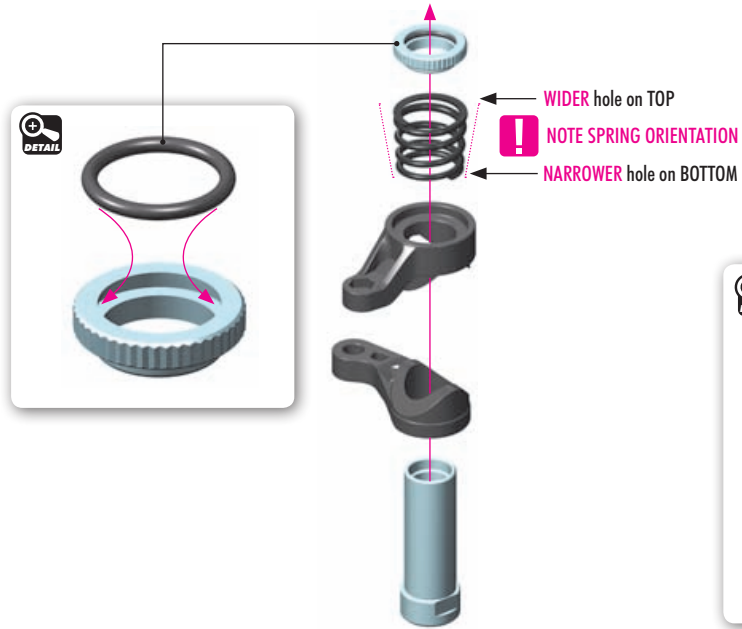

902308
SH M3x8

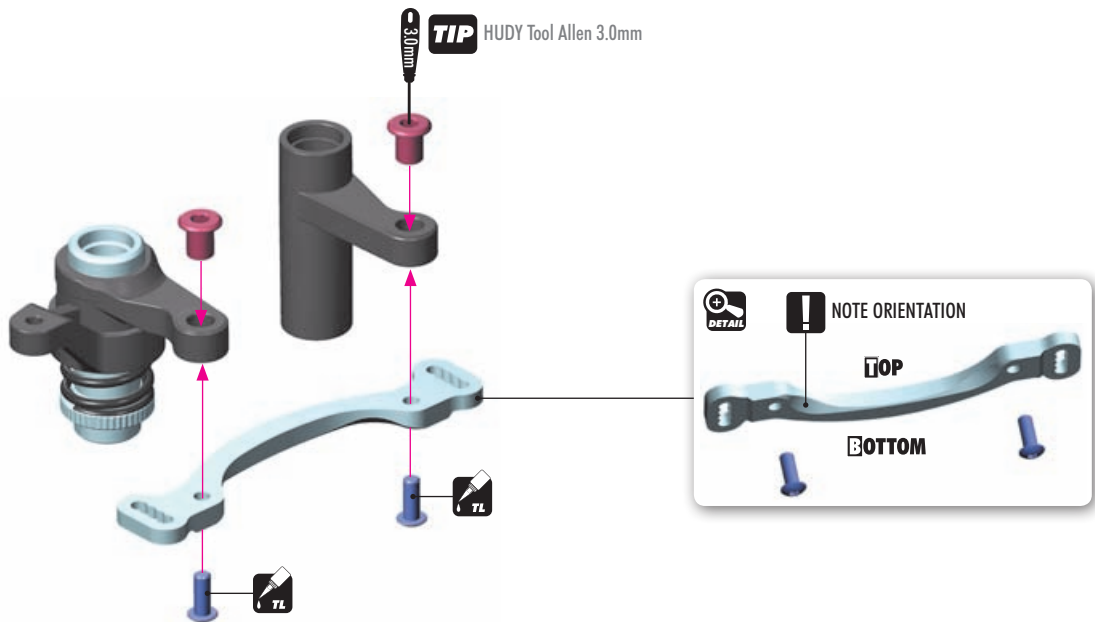

903410
SFH M4x10



940610
BB 6x10x3

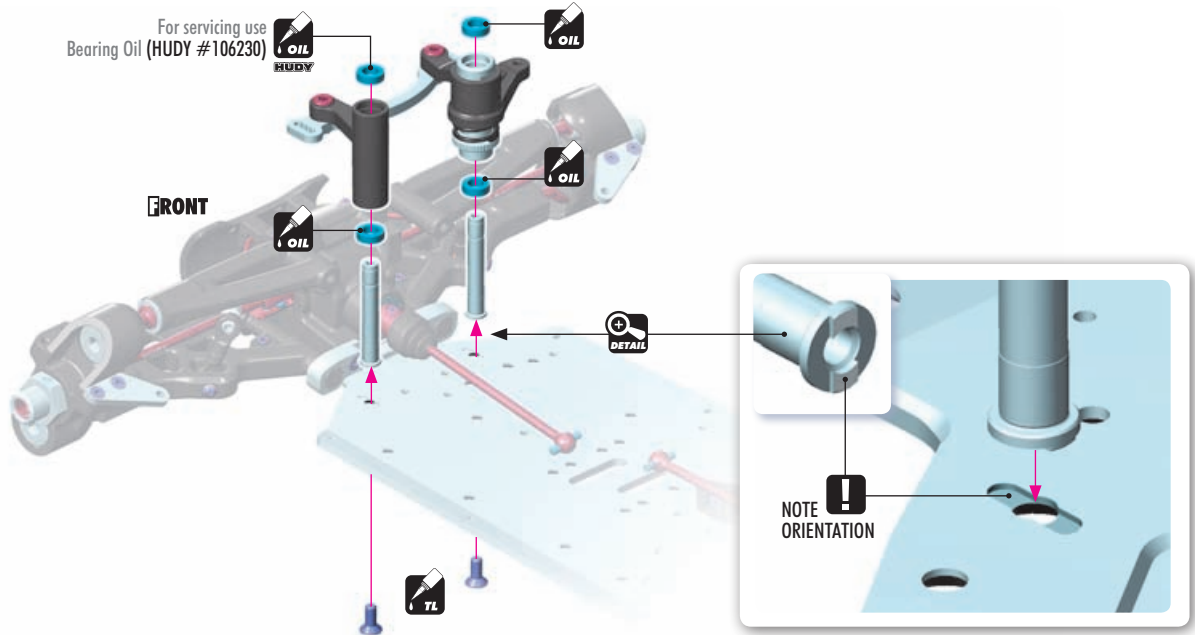



308019
SHIM 3x6x3

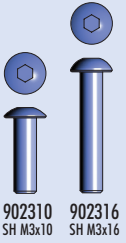

902310 SH M3x10
902316 SH M3x16



903308
SFH M3x8

SET-UP BOOK
ROLL CENTER

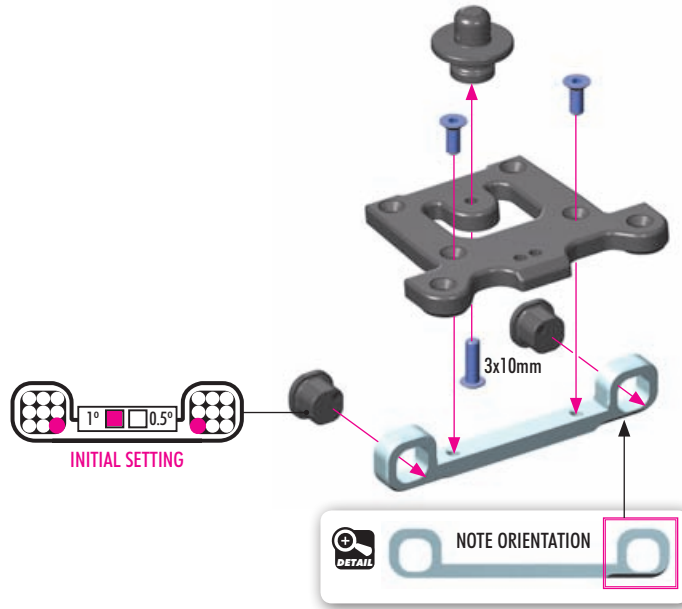

902312
SH M3x12



903310
SFH M3x10

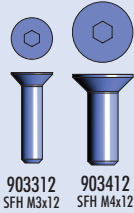

903312 SFH M3x12
903412 SFH M4x12



960030 N M3
960040 N M4

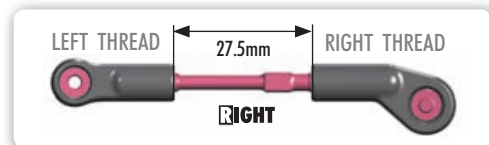
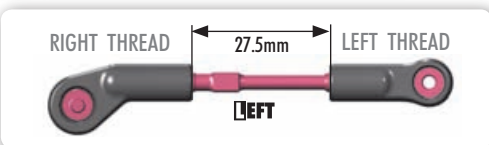
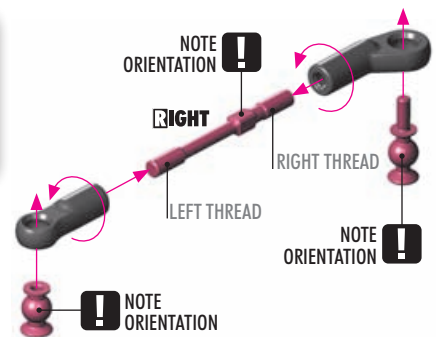
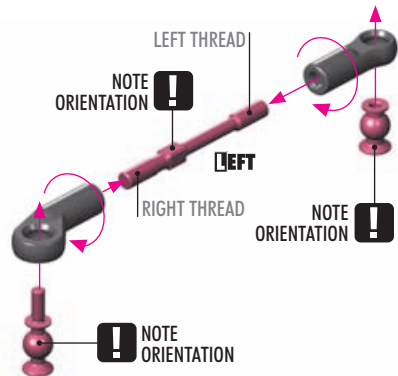
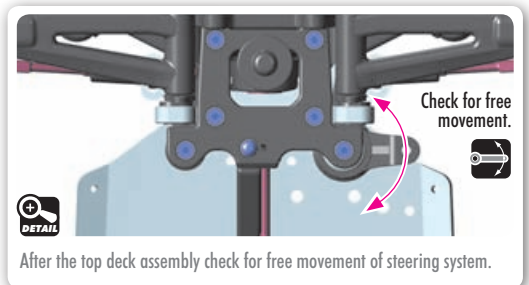
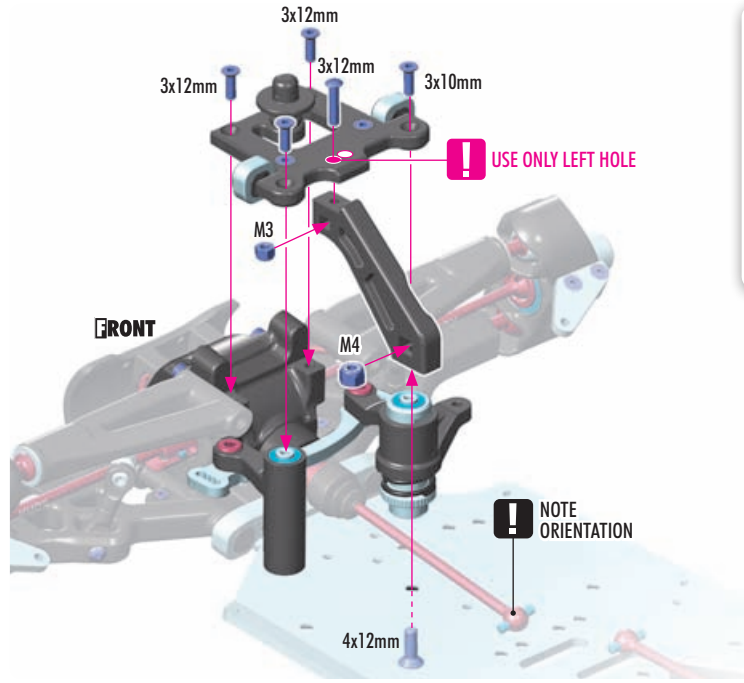

7. STEERING



908312
SCH M3x12

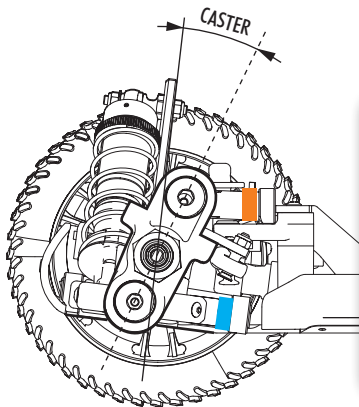
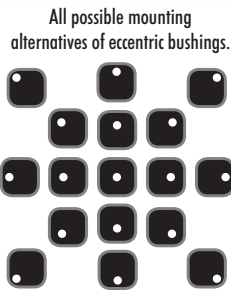
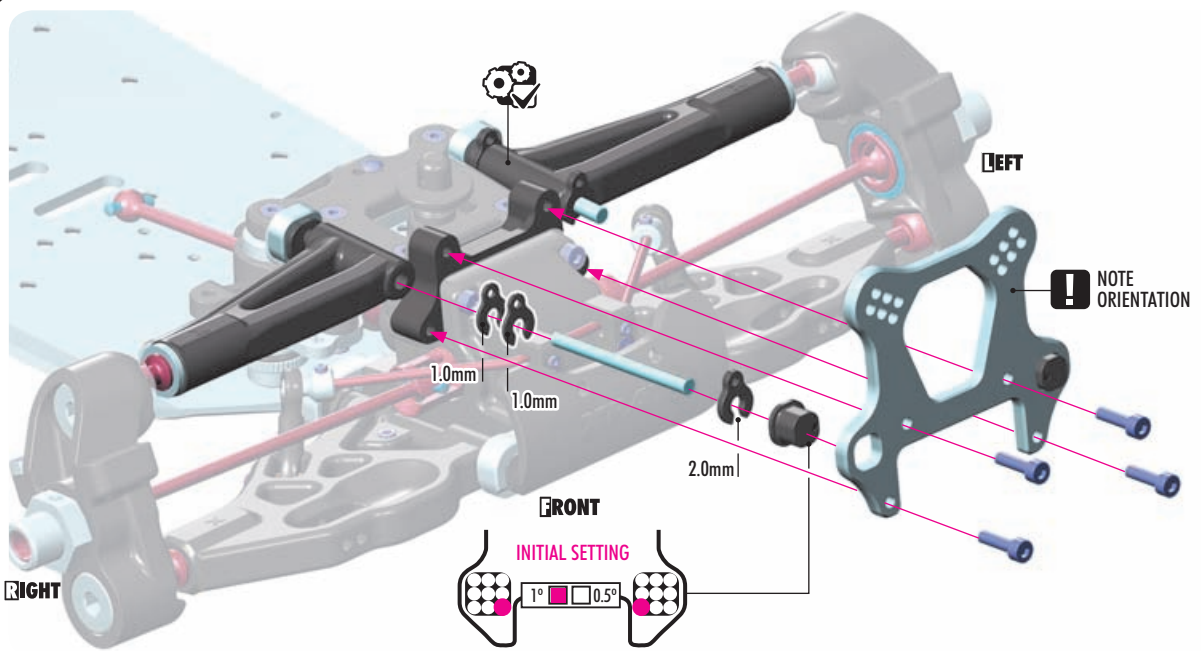

CASTER	
UPPER CLIP (Behind arm)	LOWER SHIM (Behind arm)
	2mm
4mm	21°
3mm	22.5°
2mm	24°
1mm	25.5°
0	27°

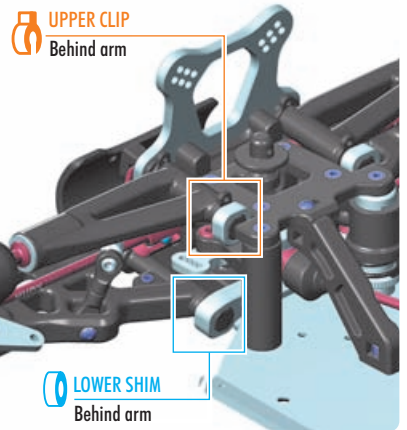

SET-UP BOOK
ROLL CENTER
CASTER



902310
SH M3x10



960030
N M3

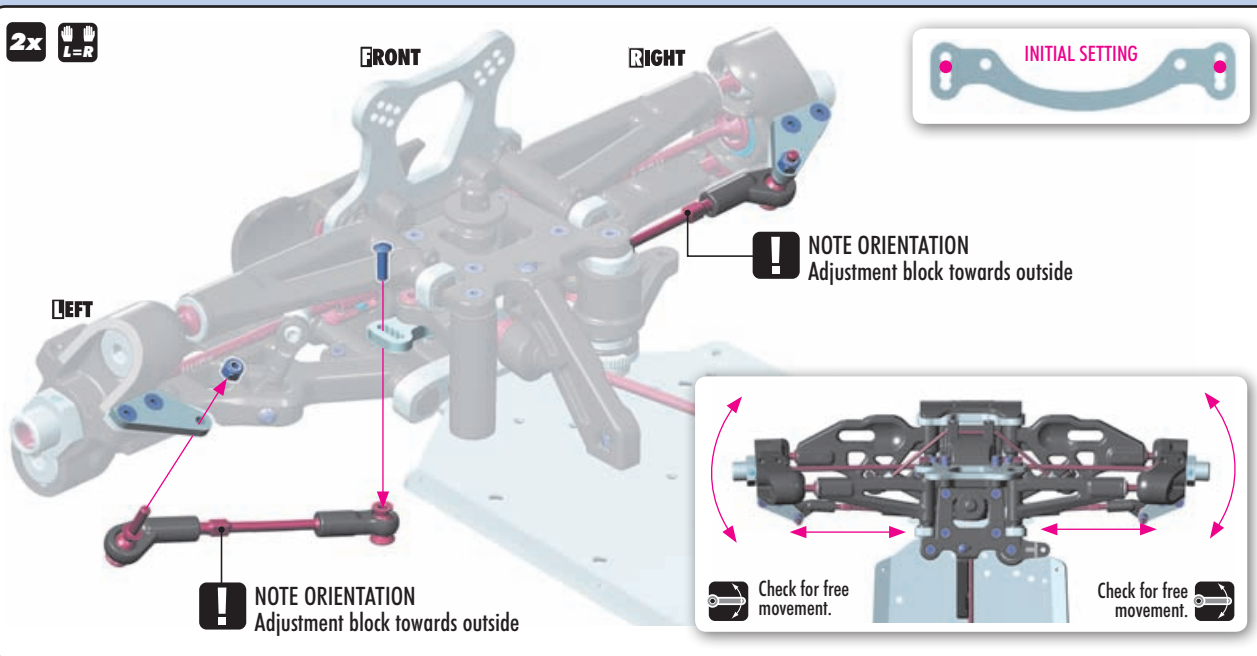

SET-UP BOOK
ACKERMANN
BUMPS STEER
TOE-IN

8. CENTER DIFF & MOTOR

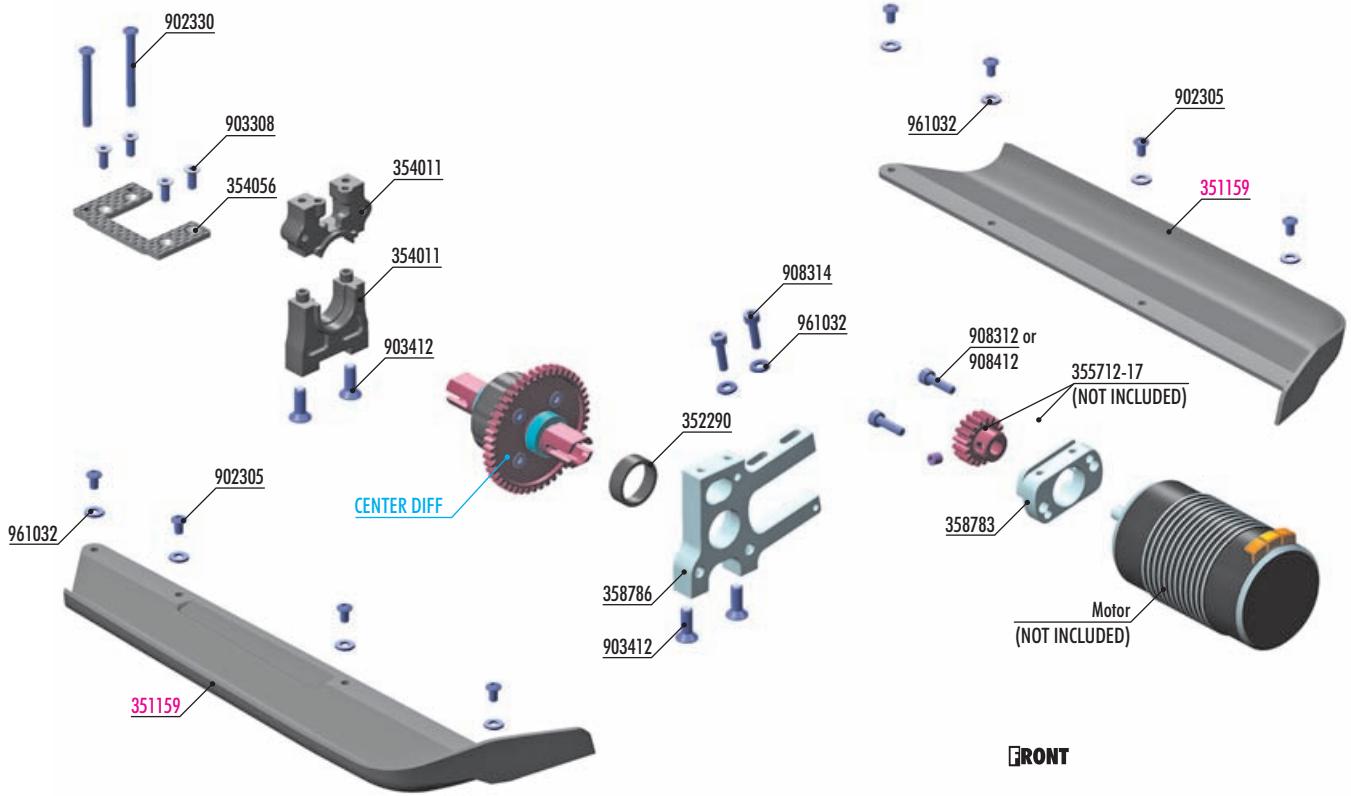

FRONT



XRAY PINION GEAR

#355712	12T	OPTION
#355713	13T	OPTION
#355714	14T	OPTION
#355715	15T	OPTION
#355716	16T	OPTION
#355717	17T	OPTION



#351159-S
COMPOSITE CHASSIS SIDE GUARD L+R - SOFT

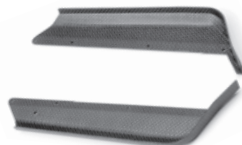

#351160
CARBON FIBER CHASSIS SIDE GUARD L+R



#353250
XB8 GRAPHITE BRACE FOR CHASSIS SIDE GUARDS - SET



BAG

08

352290 COMPOSITE BUSHING FOR ALU STEERING BLOCK (4)
354011 CENTER DIFF MOUNTING PLATE SET - HIGHER
354056 GRAPHITE CENTER DIFF MOUNTING PLATE
355712~17 XRAY 12~17T PINION GEAR (OPTION)
358783 ALU MOTOR MOUNT PLATE - V2
358786 XB8E/XT8E ALU MOTOR MOUNT
902305 HEX SCREW SH M3x5 (10)
902330 HEX SCREW SH M3x30 (10)

903308 HEX SCREW SFH M3x8 (10)
903412 HEX SCREW SFH M4x12 (10)
908312 HEX SCREW SOCKET HEAD CAP M3x12 (10)
908314 HEX SCREW SOCKET HEAD CAP M3x14 (10)
908412 HEX SCREW SOCKET HEAD CAP M4x12 (10)
961032 WASHER S 3.2 (10)

351159 CHASSIS SIDE GUARDS L+R



902305
SH M3x5



961032
S 3.2

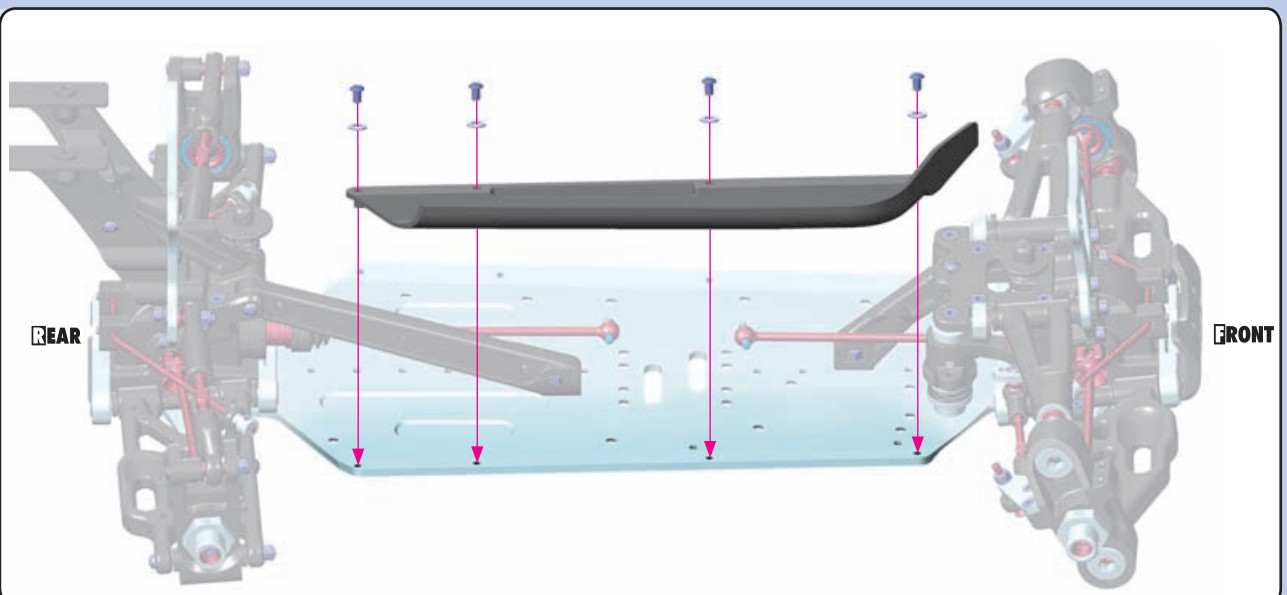

8. CENTER DIFF & BRAKE



902305
SH M3x5



961032
S 3.2

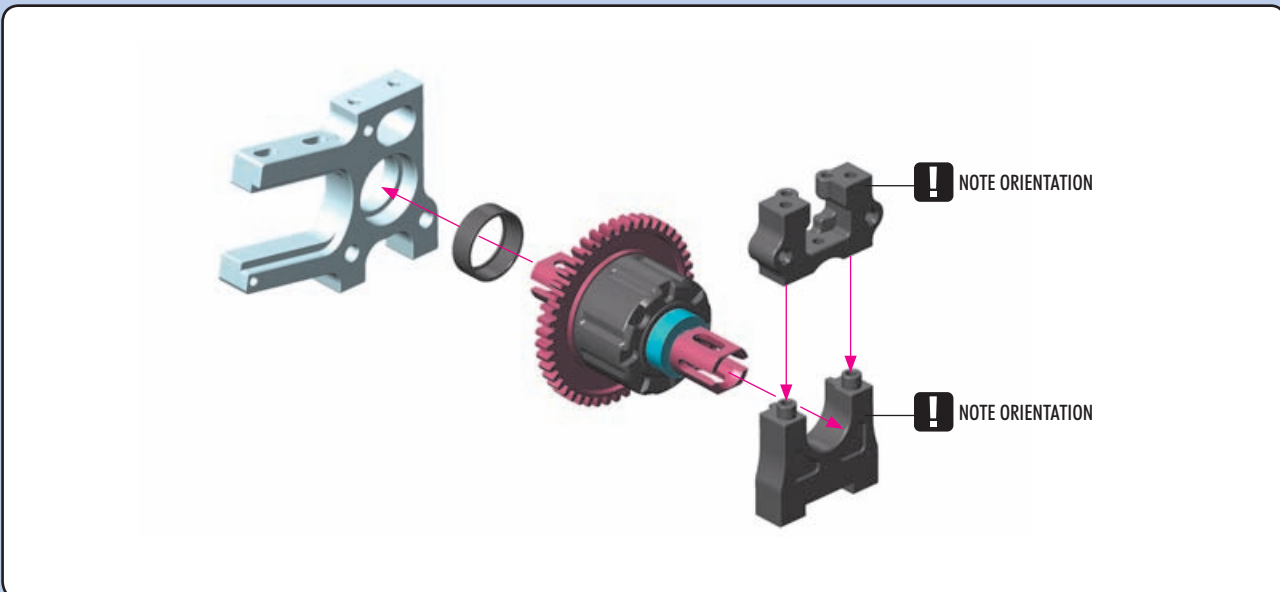
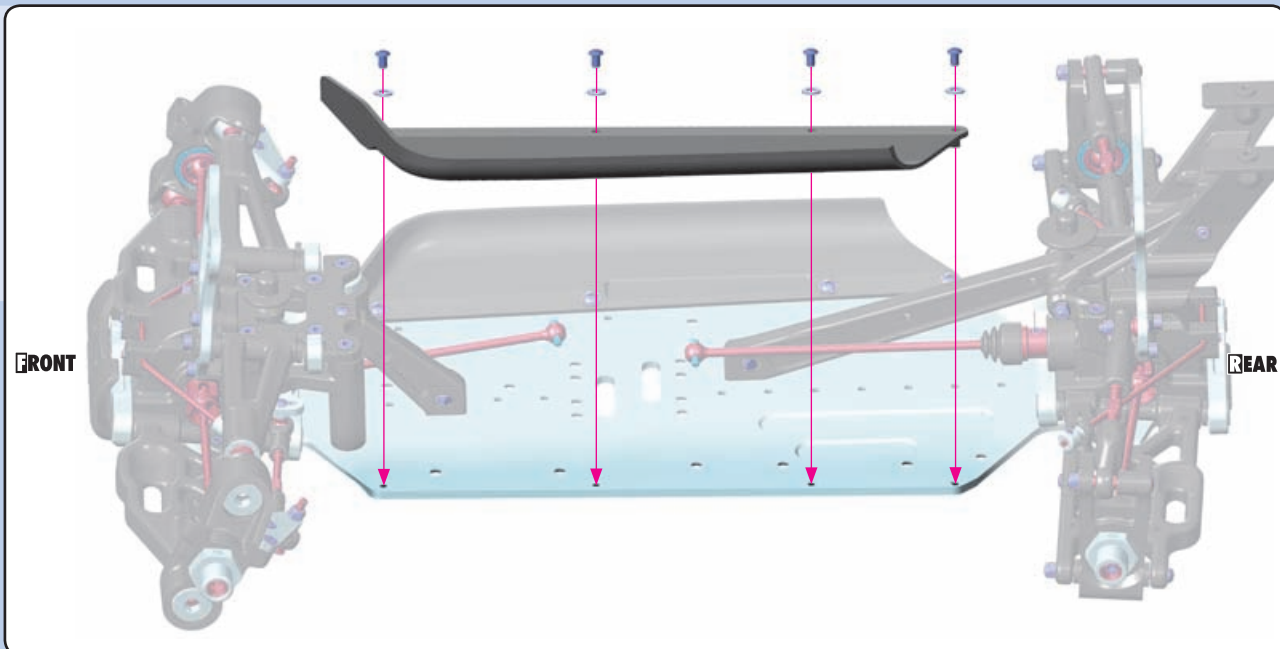

902330
SH M3x30



903308
SFH M3x8

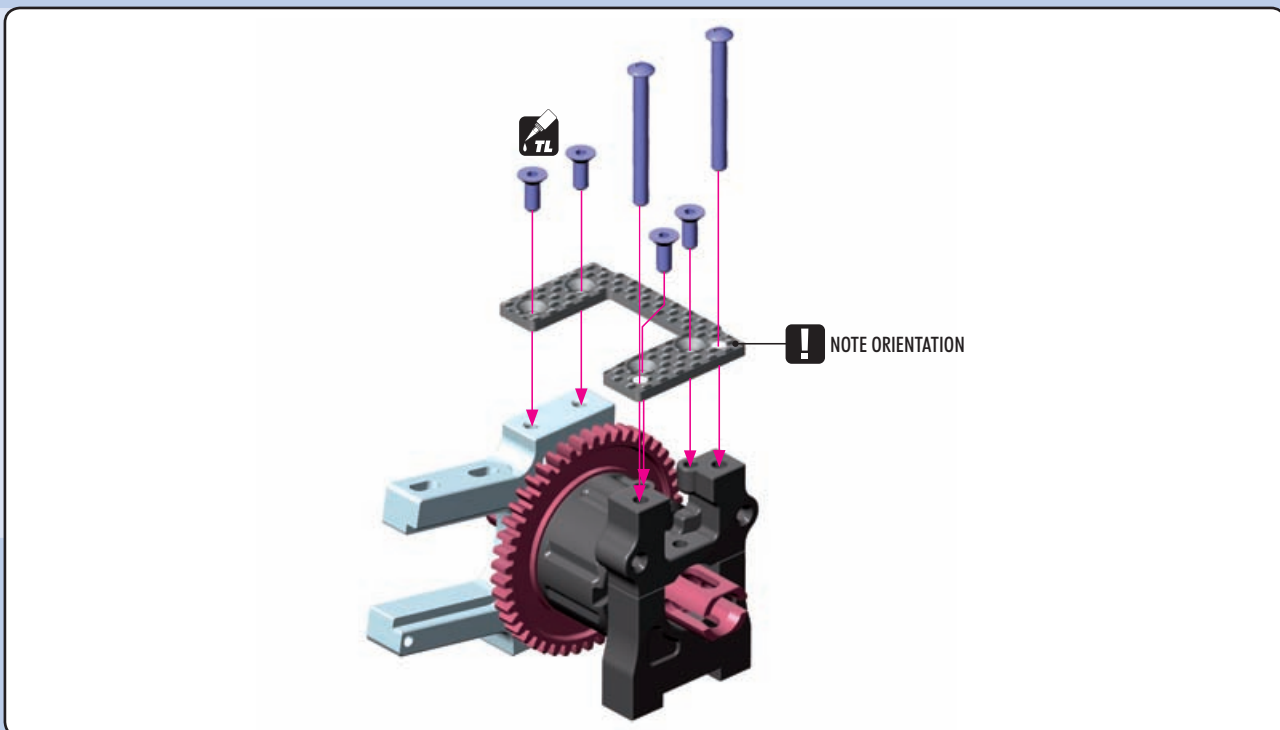

8. CENTER DIFF & BRAKE



903412
SFH M4x12

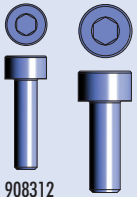
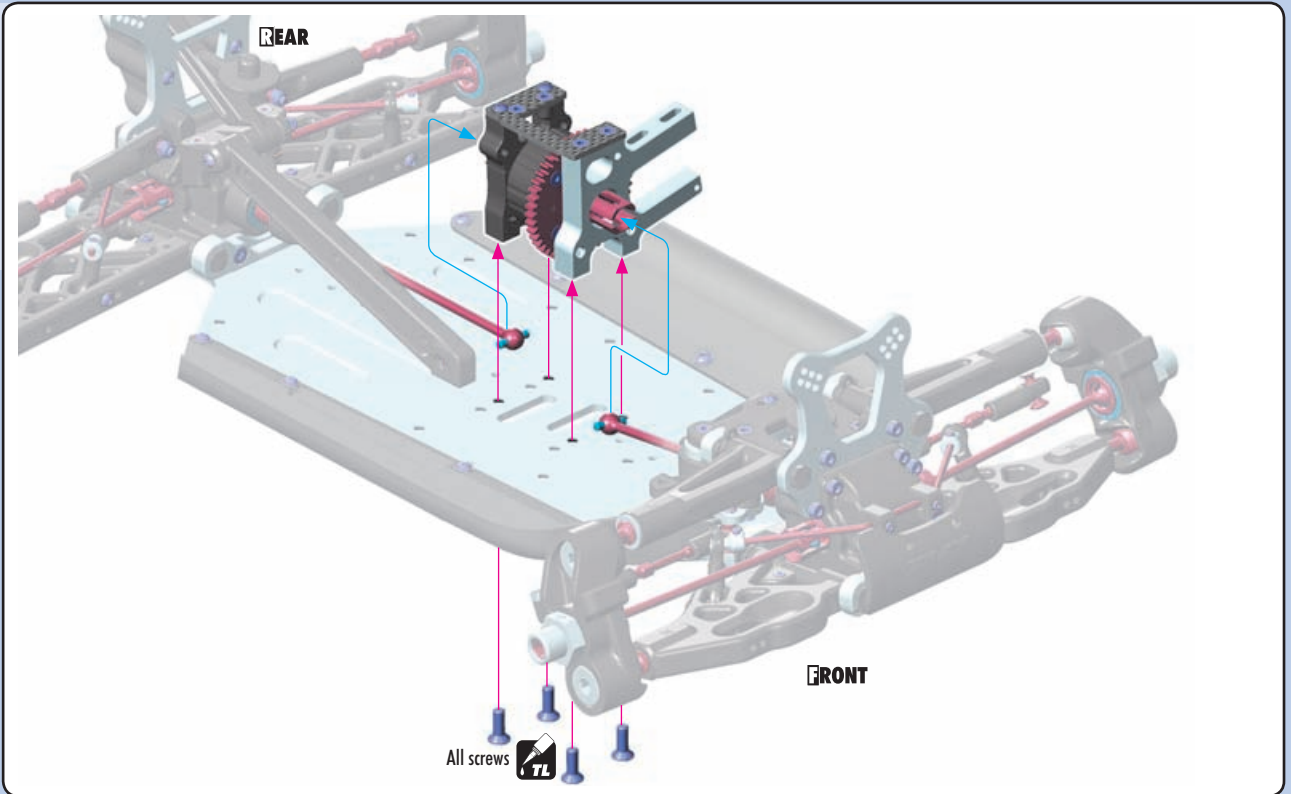

908312
SCH M3x12

908412
SCH M4x12

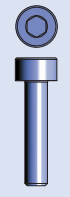
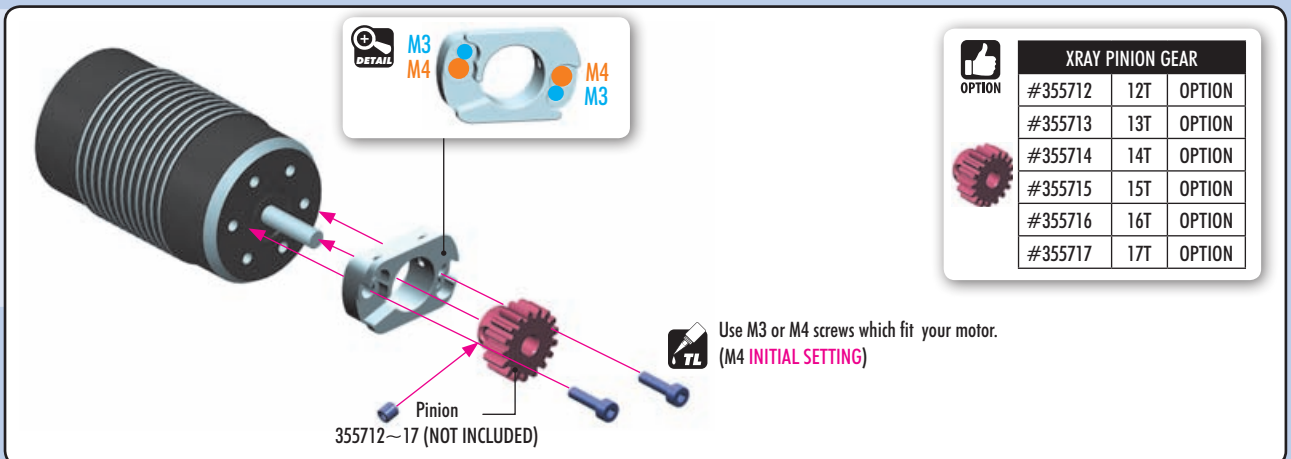

908314
SCH M3x14



961032
S3.2

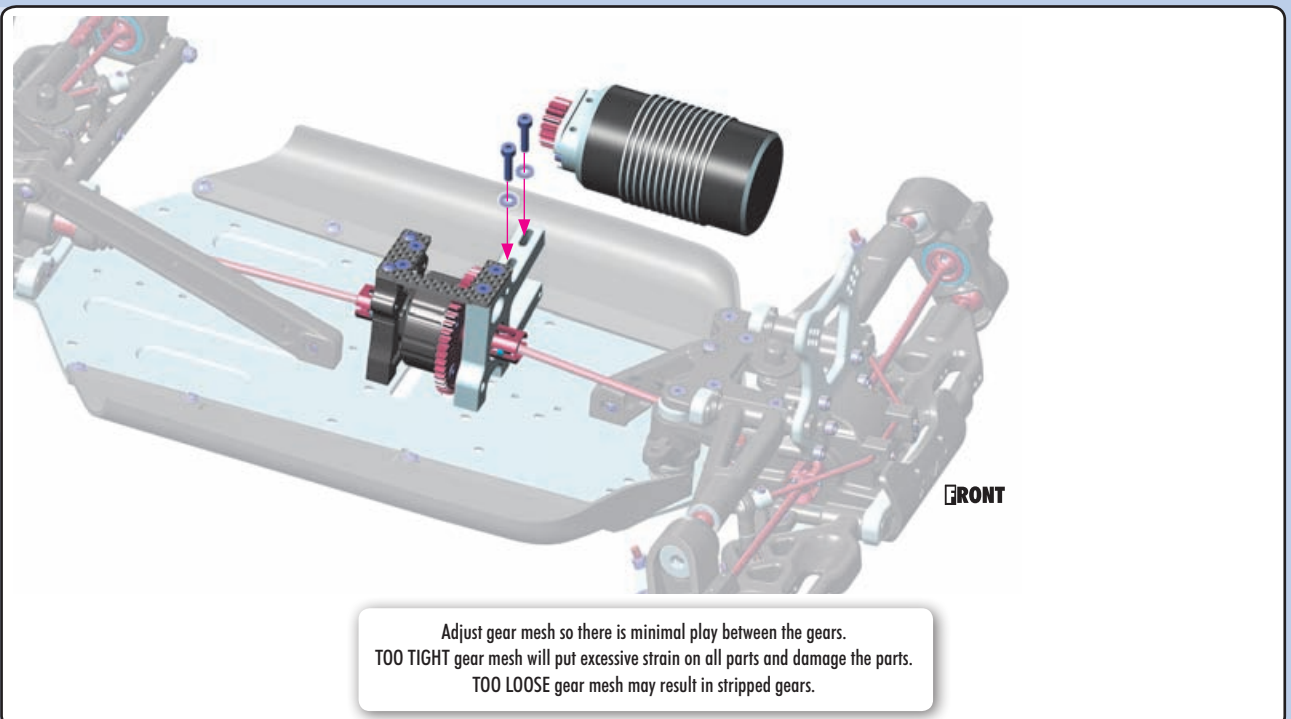

10. RADIO CASE

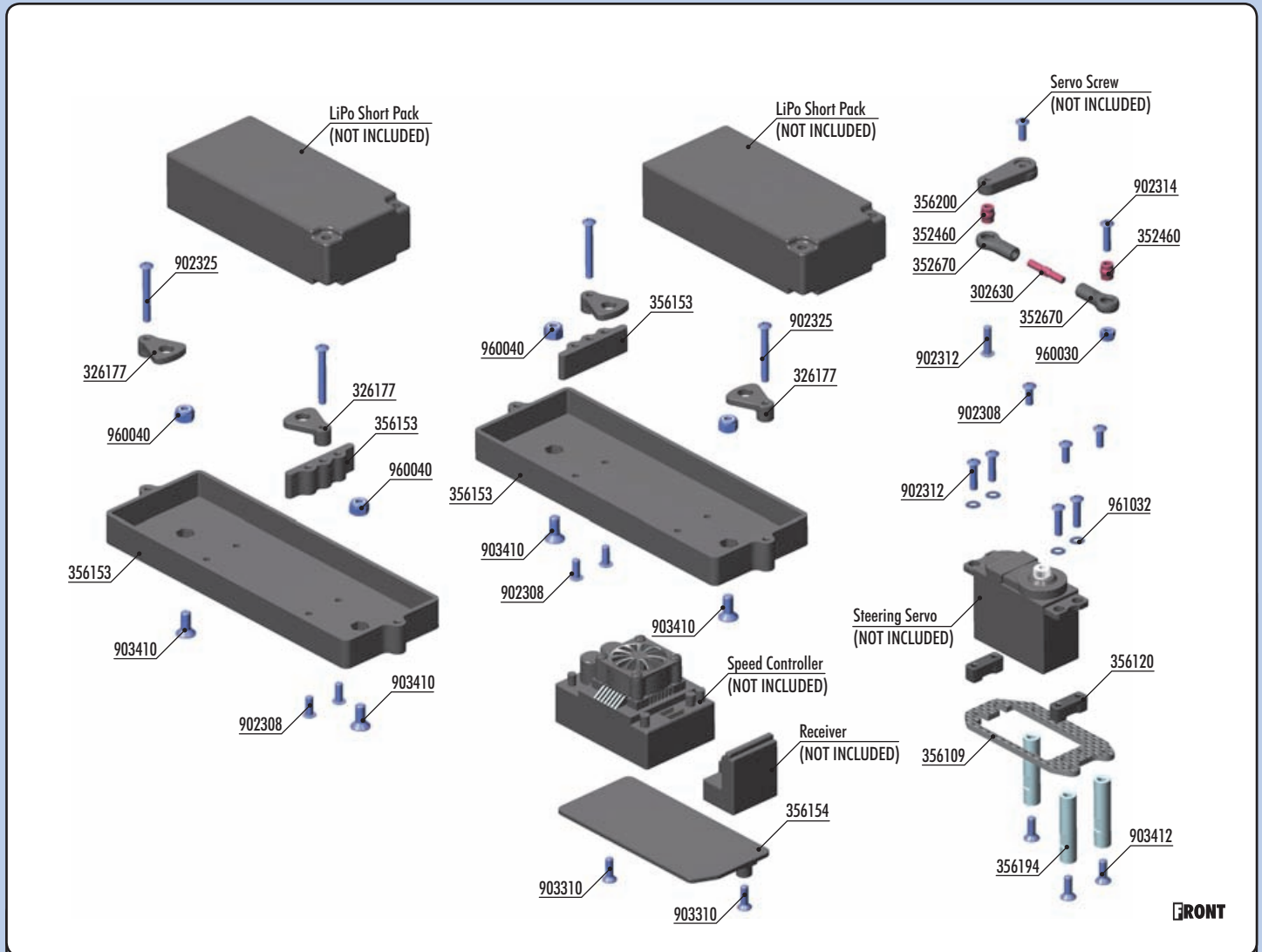

FRONT

BAG 10.1	302630	ADJ. TURNBUCKLE L/R 20 MM - HUDY SPRING STEEL™ (2)	902308	HEX SCREW SH M3x8 (10)
	352460	PIVOT BALL 5.8 (10)	902312	HEX SCREW SH M3x12 (10)
BAG 10.2	352670	SERVO BALL JOINT 5.8MM (4)	902314	HEX SCREW SH M3x14 (10)
	356120	STEERING SERVO MOUNT - SET	903412	HEX SCREW SFH M4x12 (10)
	356194	ALU MOUNT FOR RECEIVER BOX	960030	NUT M3 (10)
	356200	BRAKE/THROTTLE ARMS & STEERING SERVO ARMS - SET	961032	WASHER S 3.2 (10)
	326177	COMPOSITE BATTERY CLAMP (2)	902308	HEX SCREW SH M3x8 (10)
	356109	XB8E/GTXE/XT8E SADDLE PACK GRAPHITE SERVO HOLDER	902325	HEX SCREW SH M3x25 (10)
	356153	XB8E/GTXE/XT8E BATTERY BOX FOR STANDARD & SHORT BATTERY PACK (2)	903310	HEX SCREW SFH M3x10 (10)
	356154	COMPOSITE SPEEDO PLATE	903410	HEX SCREW SFH M4x10 (10)
			960040	NUT M4 (10)

TIP Install the pivot balls with Professional Multi-Tool (HUDY #183011).

Use appropriate servo arm:
K - (23T) H - (24T) F - (25T)

NOTE ORIENTATION

approx. 7mm

The length of the linkages varies according to the type of servo.

ALU SERVO HORNS		
#293501	23T	OPTION
#293502	24T	OPTION
#293503	25T	OPTION

CLAMP ALU SERVO HORNS		
#293407	23T	OPTION
#293408	24T	OPTION
#293409	25T	OPTION

10. RADIO CASE



902312
SH M3x12



961032
S3.2

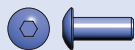
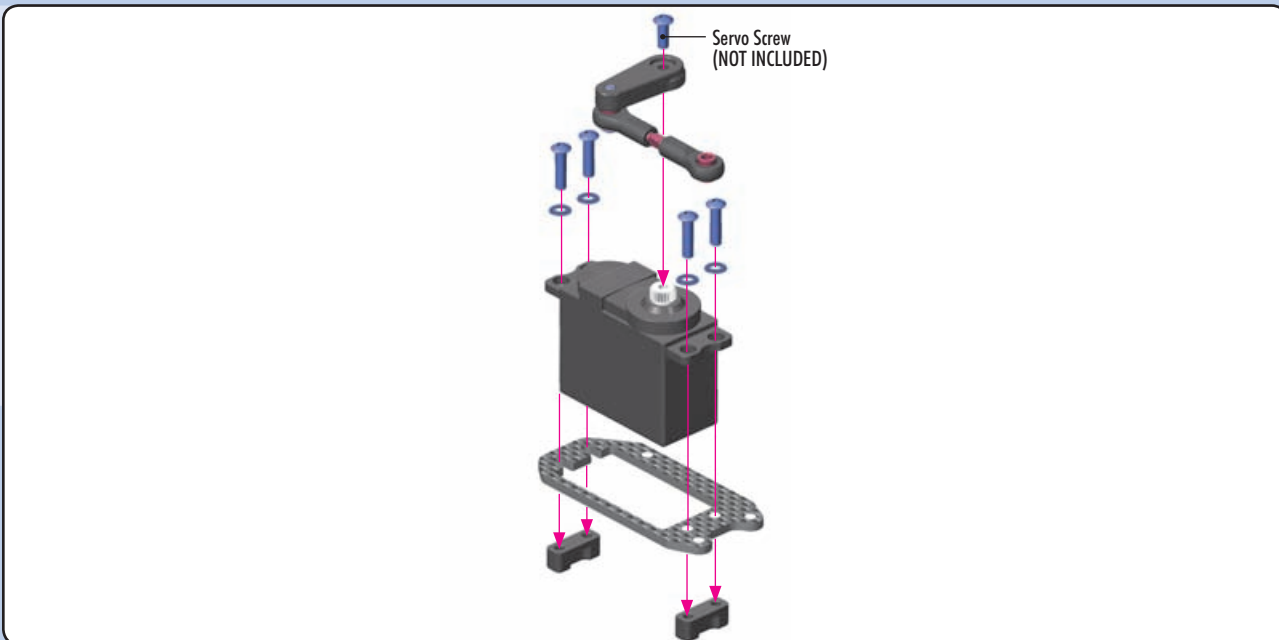

902308
SH M3x8

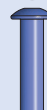
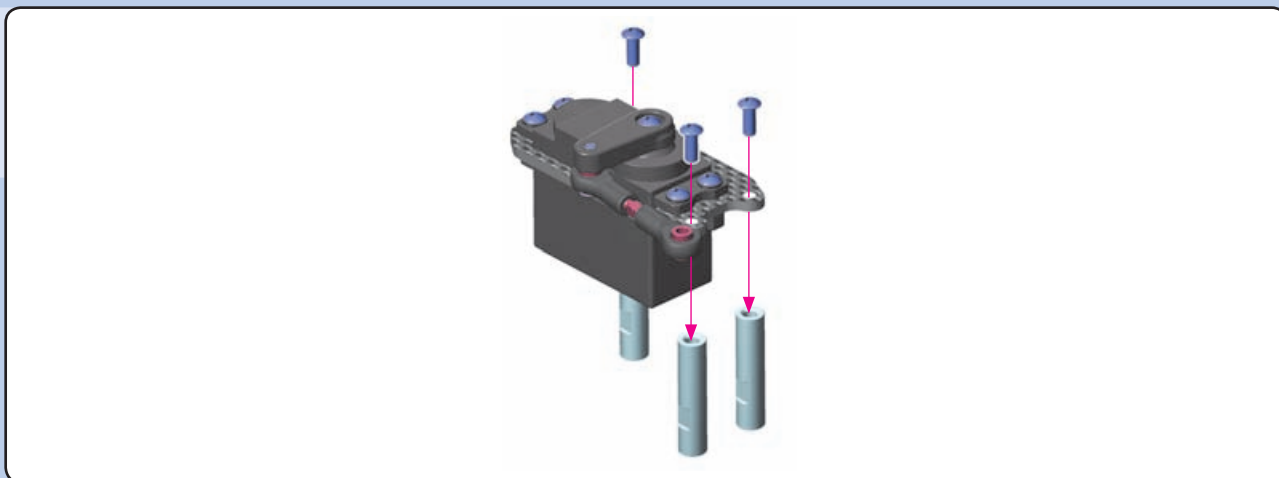

902314
SH M3x14

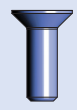

903412
SFH M4x12



960030
N M3

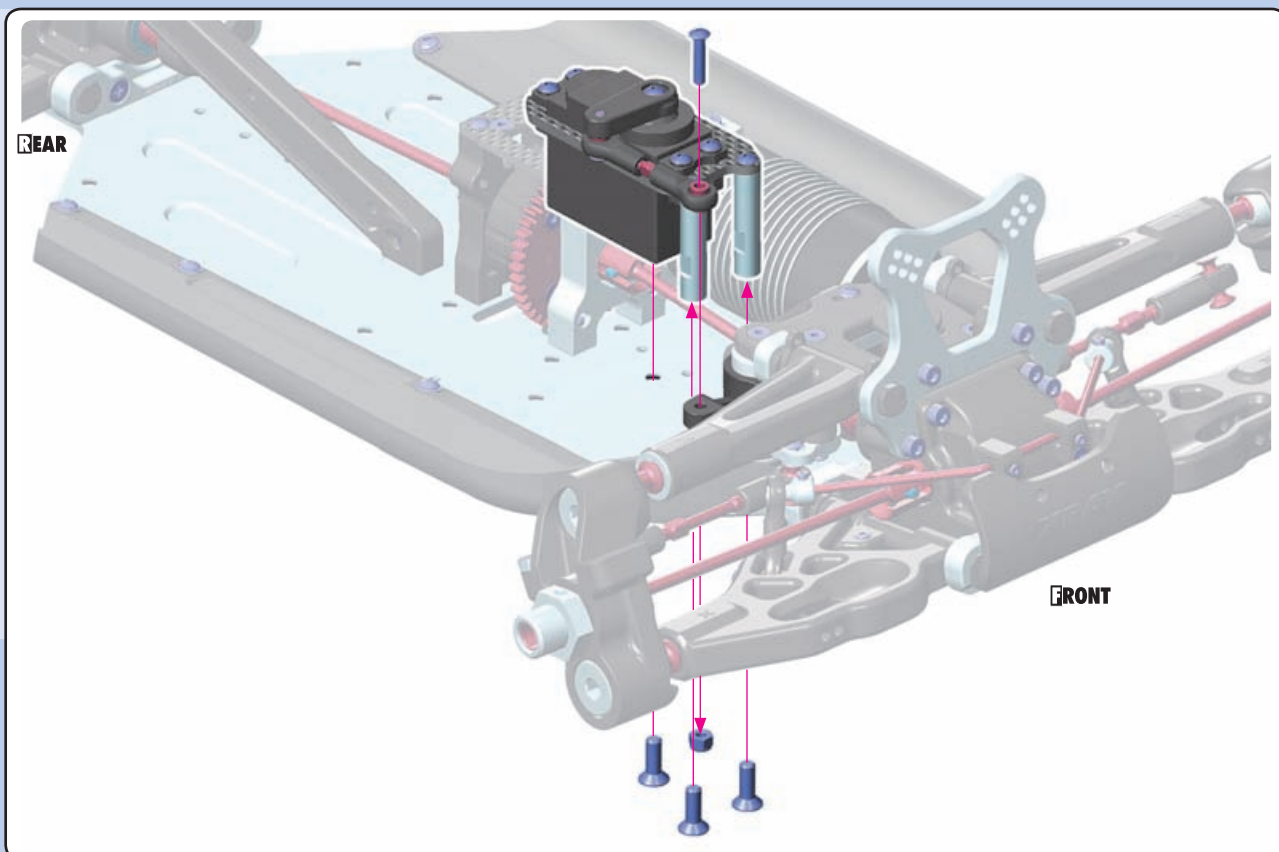

10. RADIO CASE



903310
SFH M3x10

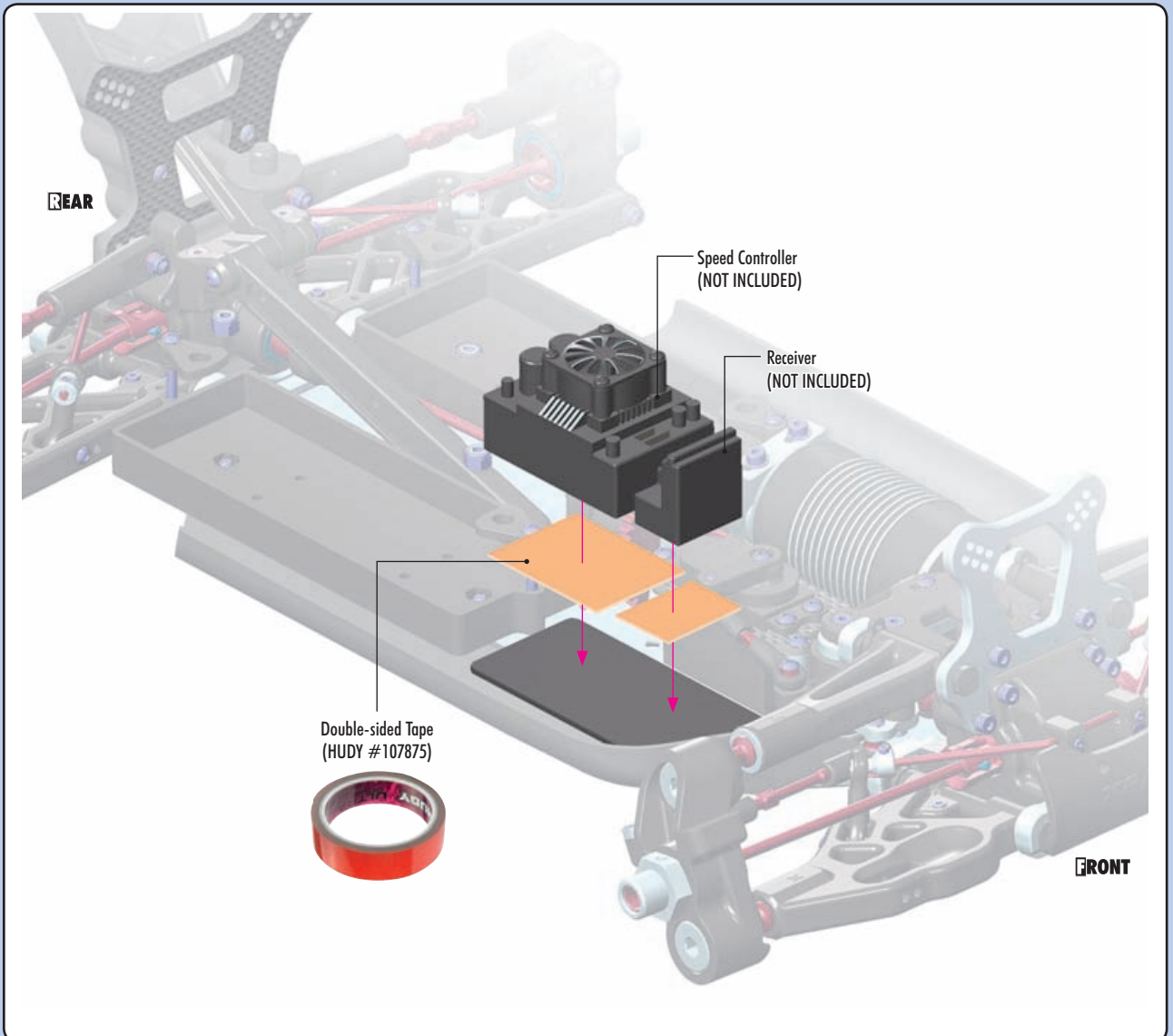
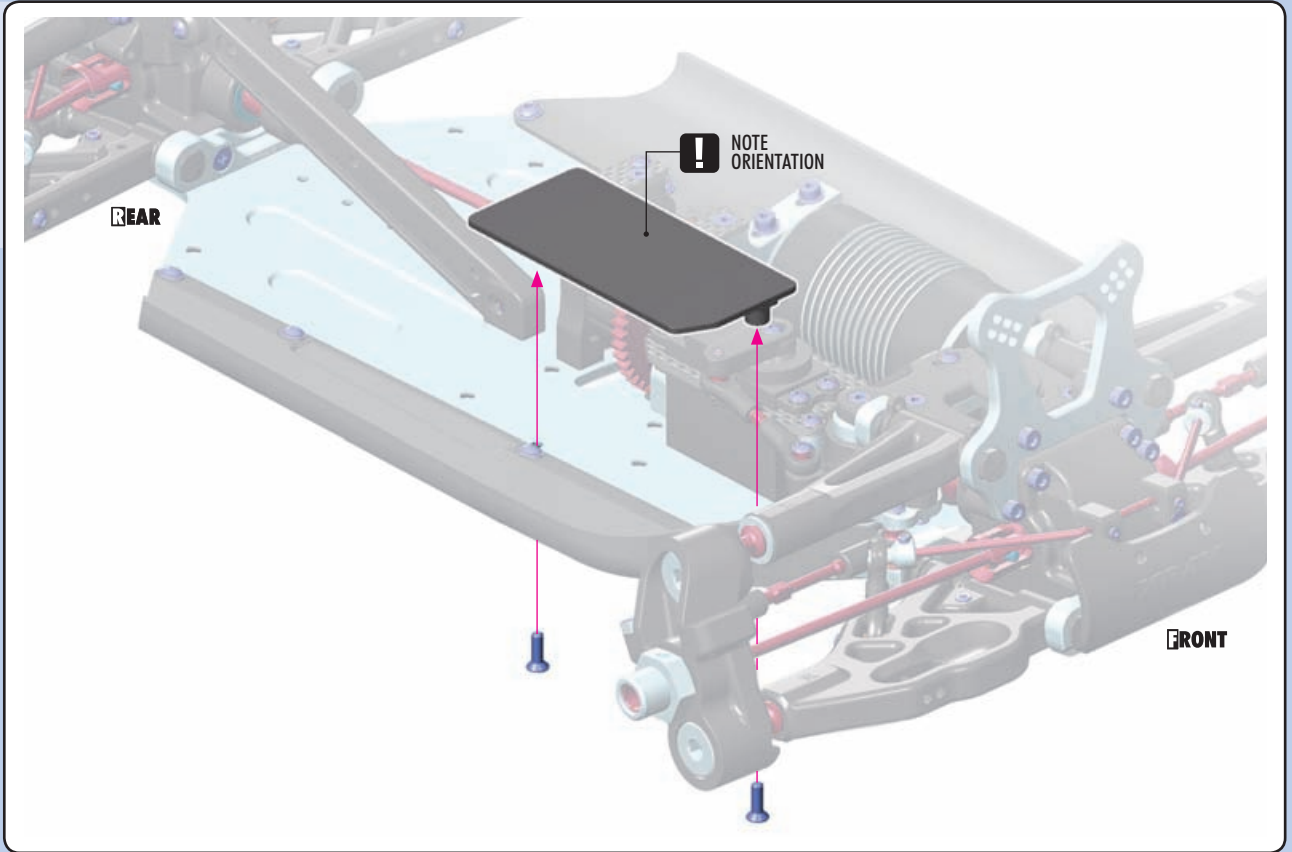

10. RADIO CASE



902325
SH M3x25



903410
SFH M4x10



960040
N M4

ALTERNATIVE 1 CONFIGURATION FOR STANDARD BATTERY PACK (INITIAL SETTING)

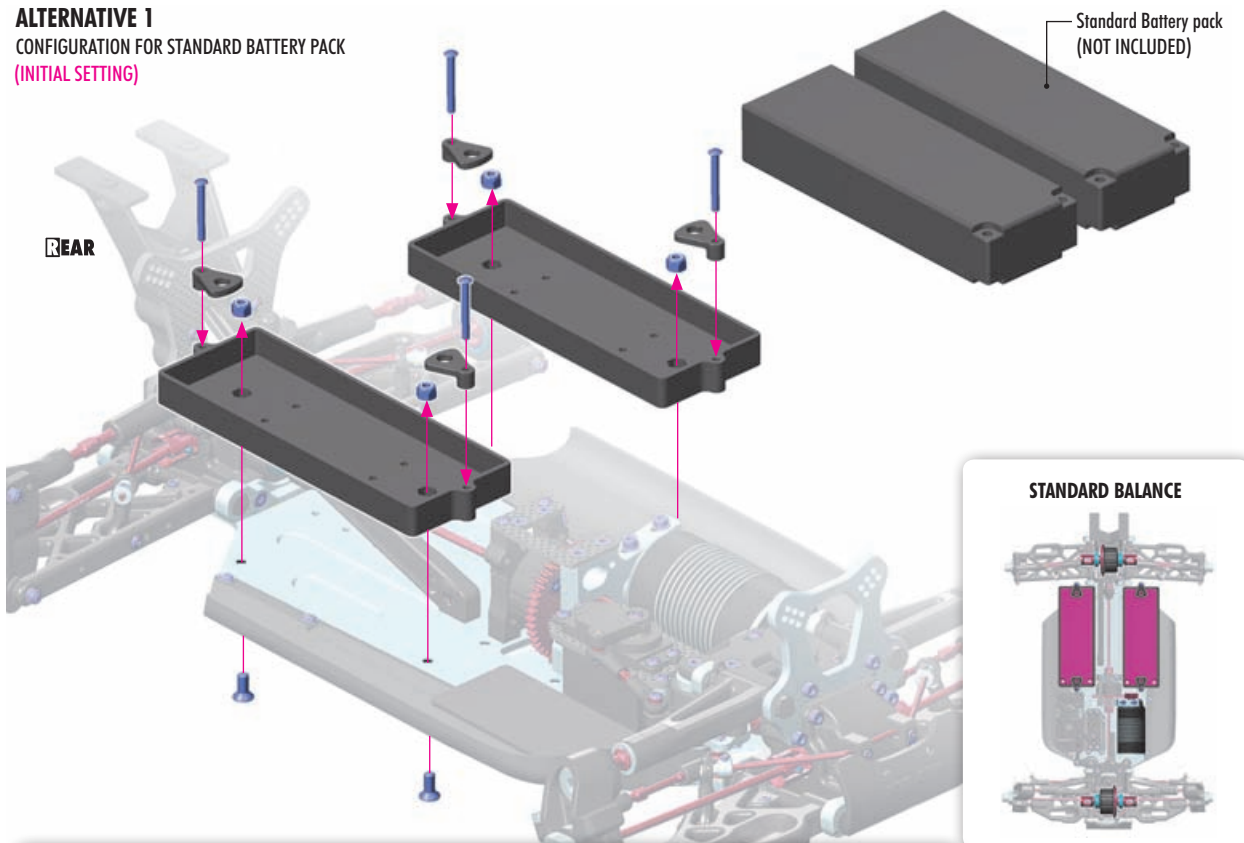

STANDARD BALANCE

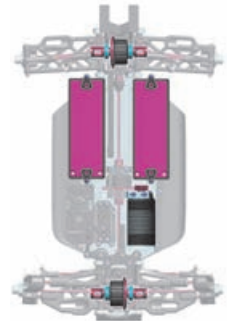

To ensure correct functioning of the battery holder, do not overtighten the screw; the holder must be able to move.



ORIENTATION FOR
LOW BATTERY
PACK

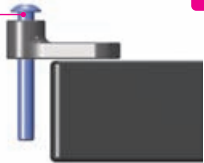

ORIENTATION FOR
STANDARD BATTERY
PACK



HEIGHT ADJUSTMENT
1 turn = 0.5mm



ALTERNATIVE 2 CONFIGURATION SHORT BATTERY PACK SETTINGS WITH BALANCE POSITION

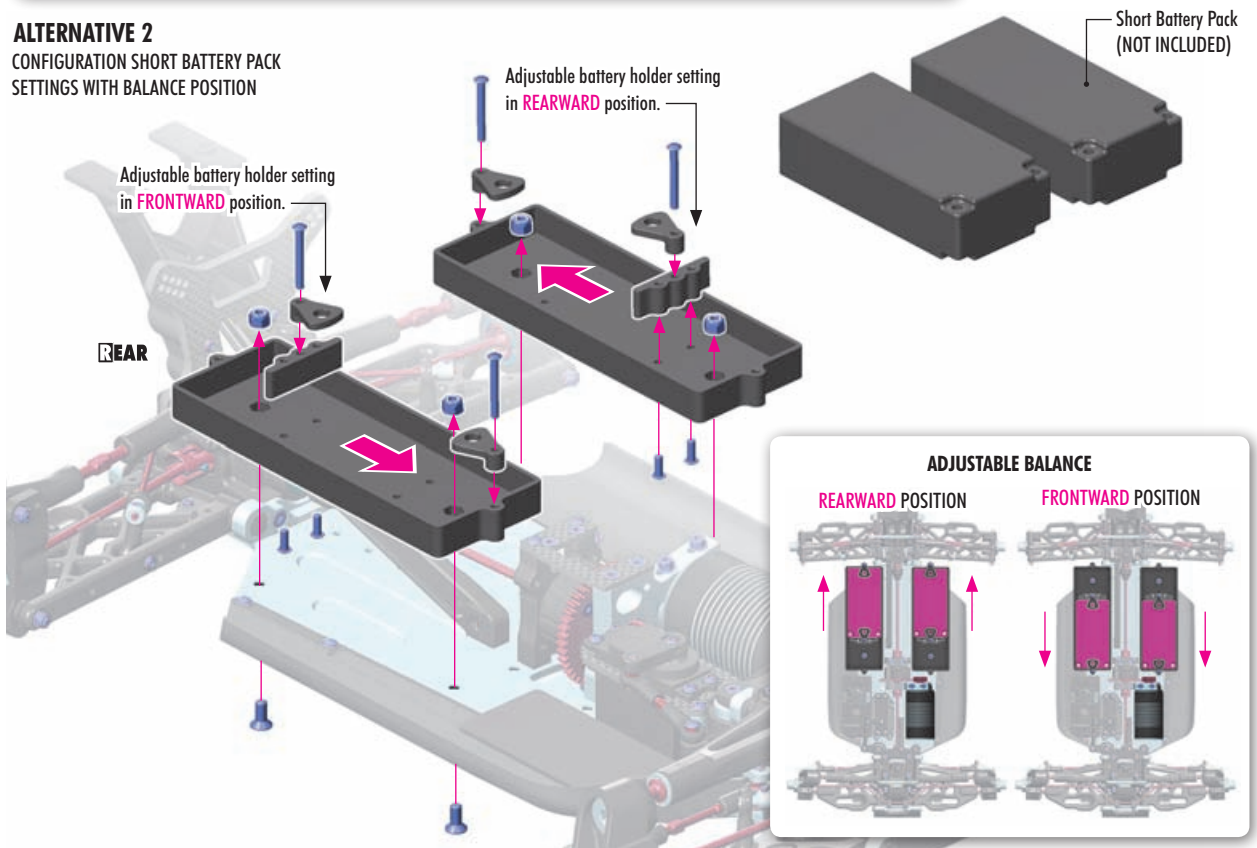

Adjustable battery holder setting
in **FRONTWARD** position.

Adjustable battery holder setting
in **REARWARD** position.

ADJUSTABLE BALANCE

REARWARD POSITION

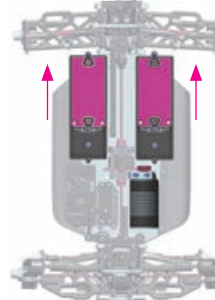

FRONTWARD POSITION

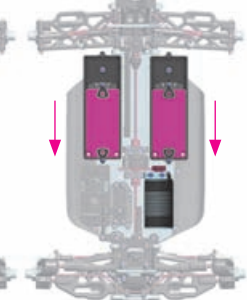

11. SHOCK ABSORBERS

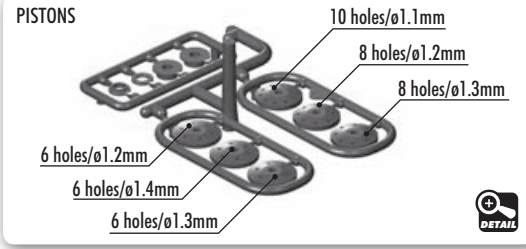
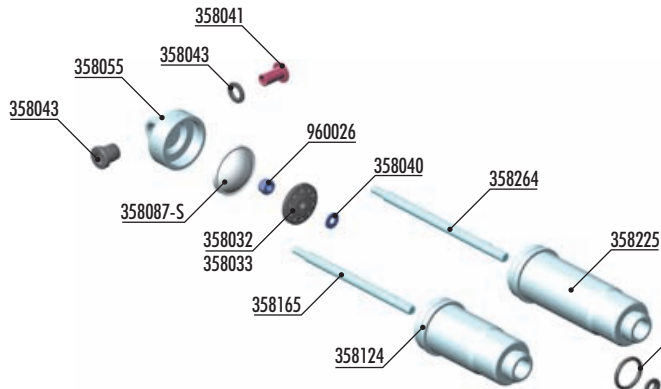

OPTION #358126 ALU FRONT SHOCK BODY -2mm (2)

OPTION #358164 FRONT SHOCK SHAFT 59mm (2)
#358265 REAR SHOCK SHAFT 71.5mm (2)

OPTION SHOCK RUBBER MEMBRANE (4)

#358084-S	BRIBBED	SOFT	OPTION
#358087-S	CELL	SOFT	INCLUDED
#358087-M	CELL	MEDIUM	OPTION

OPTION

- #358027 PISTON 5-HOLE (1.5mm) & 2-HOLE (1.0mm) (4)
- #358028 PISTON 6-HOLE (1.3mm) & 2-HOLE (1.1mm) (4)
- #308029 PISTON 6-HOLE (1.4mm) & 2-HOLE (1.1mm) (4)
- #358030 PISTON 8-HOLE (1.2mm) & 2-HOLE (1.2mm) (4)
- #358031 PISTON 8-HOLE (1.3mm) & 2-HOLE (1.2mm) (4)

OPTION #358107 XB8 FRONT SHOCK ABSORBERS ZERO REBOUND SET (2)
#358207 XB8 REAR SHOCK ABSORBERS ZERO REBOUND SET (2)

FRONT COMPLETE SET (2) REAR COMPLETE SET (2)

OPTION SHOCK SPRINGS

#358315	C=0.77-0.80	3 DOTS	FRONT	OPTION
#358316	C=0.80-0.83	4 DOTS	FRONT	INCLUDED
#358317	C=0.83-0.86	5 DOTS	FRONT	OPTION
#358334	C=0.66-0.68	2 DOTS	REAR	OPTION
#358335	C=0.68-0.70	3 DOTS	REAR	INCLUDED
#358336	C=0.70-0.73	4 DOTS	REAR	OPTION

OPTION #104005 HUDY AIR VAC - VACUUM PUMP - 1/8 OFF-ROAD

OPTION

FRONT LINEAR SPRINGS				
#358183	C=0.70	Grey	SHORT	OPTION
#358184	C=0.75	Silver	SHORT	OPTION
#358185	C=0.80	Grey-Blue	SHORT	OPTION

REAR LINEAR SPRINGS				
#358282	C=0.47	White	LONG	OPTION
#358283	C=0.50	Grey	LONG	OPTION
#358284	C=0.53	Silver	LONG	OPTION
#358285	C=0.57	Grey-Blue	LONG	OPTION
#358287	C=0.65	Violet	LONG	OPTION
#358288	C=0.70	Purple	LONG	OPTION

OPTION FRONT & REAR PROGRESSIVE SPRINGS

#358174	C=0.7-0.8	Grey	SHORT	OPTION
#358274	C=0.5-0.6	Grey	MEDIUM	OPTION
#358275	C=0.65-0.7	1 STRIPE	MEDIUM	OPTION
#358276	C=0.7-0.75	2 STRIPES	MEDIUM	OPTION

OPTION REAR PROGRESSIVE SPRINGS

#358279	C=0.55-0.63	2 STRIPES	LONG	OPTION
#358280	C=0.6-0.68	3 STRIPES	LONG	OPTION
#358281	C=0.65-0.7	4 STRIPES	LONG	OPTION

OPTION #358054 XB8 ALU SHOCK CAP NUT WITH VENT HOLE - BLACK COATED (2)

BAGS

11.1

11.2

352460	PIVOT BALL 5.8 - V3 (10)	358150	ALU SHOCK BODY ADJ. NUT (2)
358018	COMPOSITE SET OF SHIMS FOR SHOCKS - V2 (2)	358165	FRONT SHOCK SHAFT 61mm (2)
358020	COMPOSITE SHOCK PARTS	358225	ALU REAR SHOCK BODY - HARD COATED - V2 (2)
358032	SHOCK PISTON SET 8-HOLE (1.2; 1.3) 10-H. (1.1MM) - DELRIN - V2	358264	REAR SHOCK SHAFT 67.5mm (2)
358033	COMPOSITE SHOCK 6-HOLE PISTON SET (1.2; 1.3; 1.4MM) - DELRIN - V2	960026	NUT M2.5 - SHORT (10)
358040	HARDENED SHOCK SHIMS (4)	970100	O-RING 10 x 1.5 (10)
358041	STEEL SHOCK BUSHING (2)	970180	O-RING 18 x 1.8 (10)
358043	COMPOSITE SHOCK BUSHING & SHIM (2+2)	971034	SILICONE O-RING 3.5x2 (10)
358055	ALU SHOCK CAP NUT WITH 4 VENT HOLES - BLACK COATED (2)	358316	XRAY FRONT SPRING 69MM - 4 DOTS (2)
358074	FOLDING SHOCK BOOT (4)	358335	XRAY REAR SPRING 85MM - 3 DOTS
358087-S	SHOCK RUBBER MEMBRANE CELL - SOFT (4)		
358124	ALU FRONT SHOCK BODY - HARD COATED - V2 (2)		
358142	ALU SHOCK BODY NUT FOR SHOCK BOOT (2)		

11. SHOCK ABSORBERS



358040
5 2.5x6x0.5



960026
N M2.5

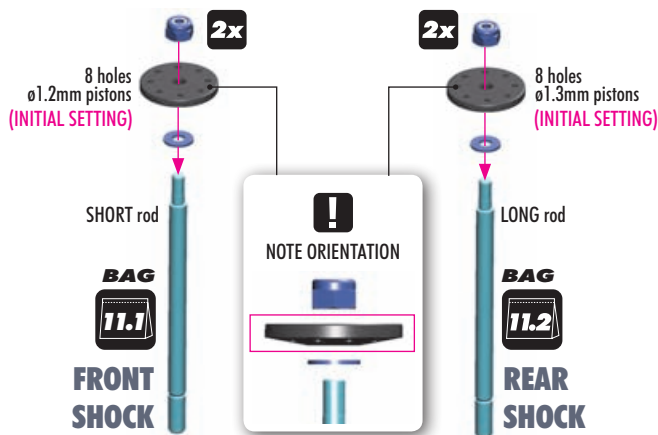

Install the piston with Professional Multi Tool (HUDY #183011).

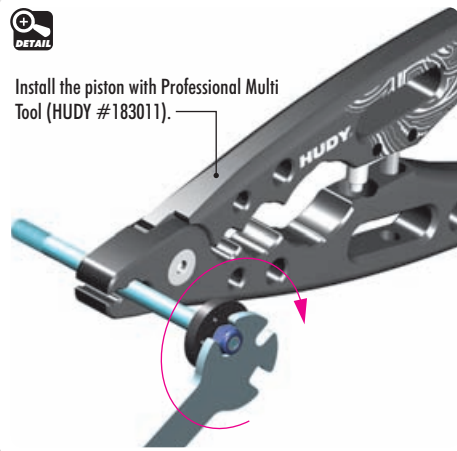

#358265
REAR SHOCK SHAFT 71.5mm (2)



#358027 PISTON 5-HOLE (1.5mm) & 2-HOLE (1.0mm) (4)
#358028 PISTON 6-HOLE (1.3mm) & 2-HOLE (1.1mm) (4)
#308029 PISTON 6-HOLE (1.4mm) & 2-HOLE (1.1mm) (4)
#358030 PISTON 8-HOLE (1.2mm) & 2-HOLE (1.2mm) (4)
#358031 PISTON 8-HOLE (1.3mm) & 2-HOLE (1.2mm) (4)



DO NOT OVERTIGHTEN

The self-locking nut is overtightened, causing distortion of the piston. This will negatively affect the free movement of the piston in the shock body.



TIGHTEN GENTLY

The self-locking nut is gently tightened. The piston remains undistorted and fits inside the shock body perfectly, ensuring smooth movement of the piston.

SET-UP BOOK
SHOCK DAMPING
SHOCK PISTONS



970100
0 10x1.5



971034
0 3.4x2

2x FRONT SHOCKS (SHORT)

2x REAR SHOCKS (LONG)

There are two different thickness shims, use them as shown. Use the same procedure when building both front and rear shocks.

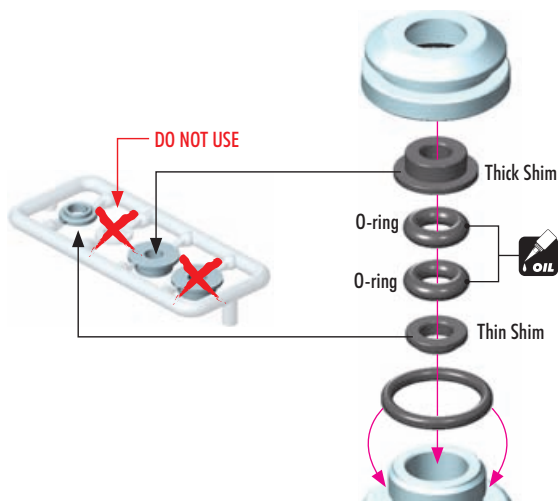

2x

FRONT SHOCKS

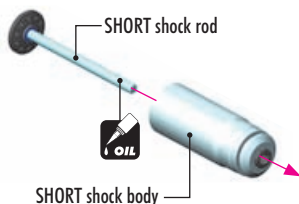

2x

REAR SHOCKS

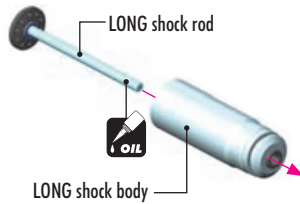

EXTREMELY IMPORTANT

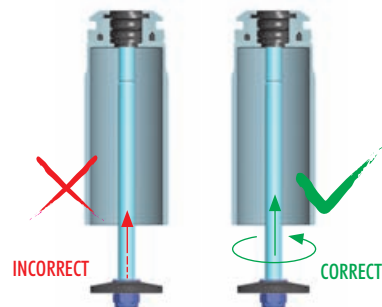

Do not push the shock rod straight through the lower shock body assembly; O-ring damage may result.

Twist the shock rod through the lower shock body assembly.

11. SHOCK ABSORBERS



970180
0 18x1.8

2x FRONT SHOCKS

2x REAR SHOCKS

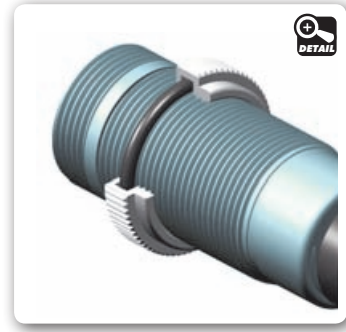
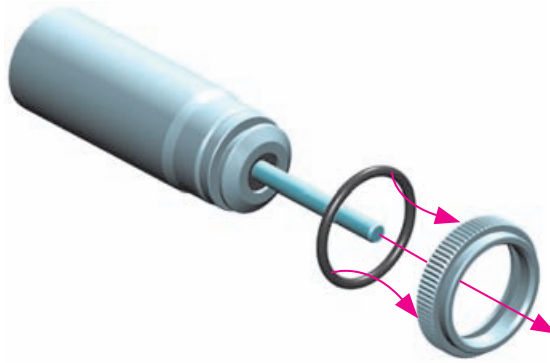

2x FRONT SHOCKS

2x REAR SHOCKS

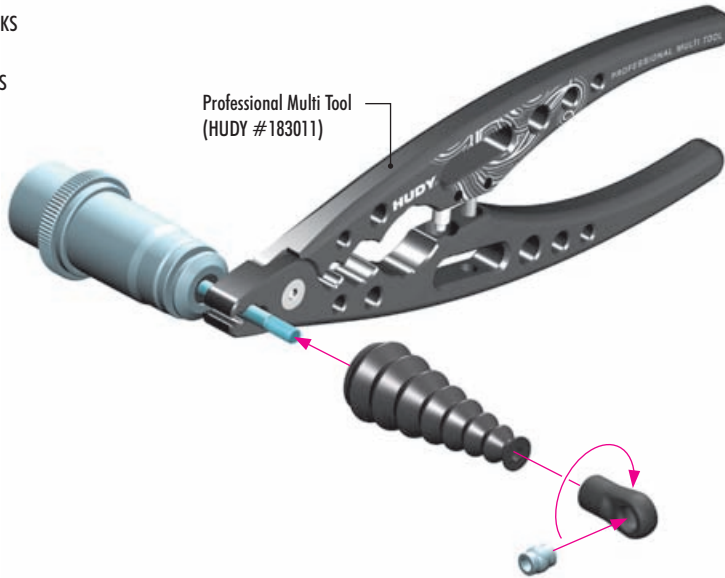

Professional Multi Tool
(HUDY #183011)

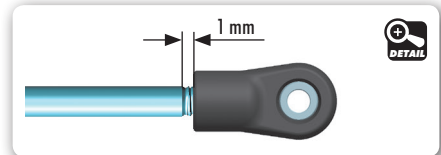
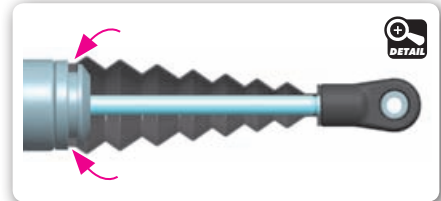

DEFAULT SHOCK REBOUND SETTING 0% (LOW REBOUND)

Follow the steps below to set the shock rebound to the default setting of 0%.

2x FRONT (SHORT)

Oil 550cSt

2x REAR (LONG)

Oil 600cSt

SET-UP BOOK
SHOCK OIL



1 Extend the shock shaft completely. Fill the shock body with the shock oil. For the FRONT shocks (short) use 550cSt oil. For the REAR shocks (long) use 600cSt oil.



2 Move the shock shaft up and down a few times to release the air bubbles trapped beneath the piston.



3 Orient the filled shock vertically for several minutes with the shock shaft fully extended. The remaining air bubbles will release.



4 Install the shock membrane into the groove in the upper shock cap.



5 Gently place the shock cap assembly onto the filled shock body. Excess oil will spill from the shock. Screw the shock cap onto the body by only a few turns.

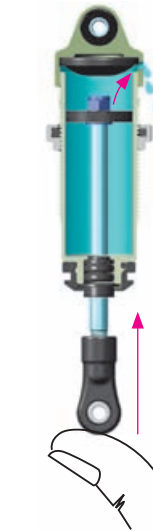

6 Gently push the shock shaft completely into the shock body. Excess oil will flow through the hole in the shock cap.



7 Keep the shock shaft pushed in the shock body and tighten the shock cap completely. The rebound will be at approximately 0%.

11. SHOCK ABSORBERS

2x REAR SHOCKS
LONG rear shock

2x FRONT SHOCKS
SHORT front shock

LONG spring

SHORT spring

REAR shock PRELOAD
approx. 2mm

FRONT shock PRELOAD
approx. 2mm

FRONT & REAR SHOCKS
IMPORTANT!

IMPORTANT! Both rear shocks must be the same overall length.

IMPORTANT! Both front shocks must be the same overall length.

SET-UP BOOK
SPRING RATE
SHOCK PRELOAD
RIDE HEIGHT

TIP ALTERNATE SHOCK REBOUND SETTING (50% AND 100%)

The default shock rebound setting is 0% (as described on page 40). Alternatively, you may set the shock rebound setting to 50% or 100% as described below. Remove the shock springs before performing shock rebound adjustment.

SETTING THE SHOCK REBOUND TO 50% (MEDIUM REBOUND)

1 REMOVE SHOCK CAP
Extend the shock shaft completely and remove the shock cap.

2
Fill the shock body with shock oil up to the top. Make sure to use same viscosity shock oil as is in the shock.

3
Orient the filled shock vertically for several minutes with the shock shaft fully extended. The remaining air bubbles will release.

4 HALF TIGHTEN 50%
Gently place the shock cap assembly onto the filled shock body. Excess oil will spill from the shock.

5
Push the shock shaft 50% into the shock body. Excess oil will bleed through the hole in the shock cap.

6 TIGHTEN FULLY 100%
Keep the shock shaft pushed 50% into the shock body and tighten the shock cap completely. The rebound will be at approximately 50%.

SETTING THE SHOCK REBOUND TO 100% (HIGH REBOUND)

1 REMOVE SHOCK CAP
Extend the shock shaft completely and remove the shock cap.

2
Fill the shock body with shock oil up to the top. Make sure to use same viscosity shock oil as is in the shock.

3
Orient the filled shock vertically for several minutes with the shock shaft fully extended. The remaining air bubbles will release.

4 TIGHTEN FULLY 100%
Gently place the shock cap assembly onto the filled shock body. Keep the shock shaft extended 100% from the shock body and tighten the shock cap completely. The rebound will be at approximately 100%.

12. FINAL ASSEMBLY

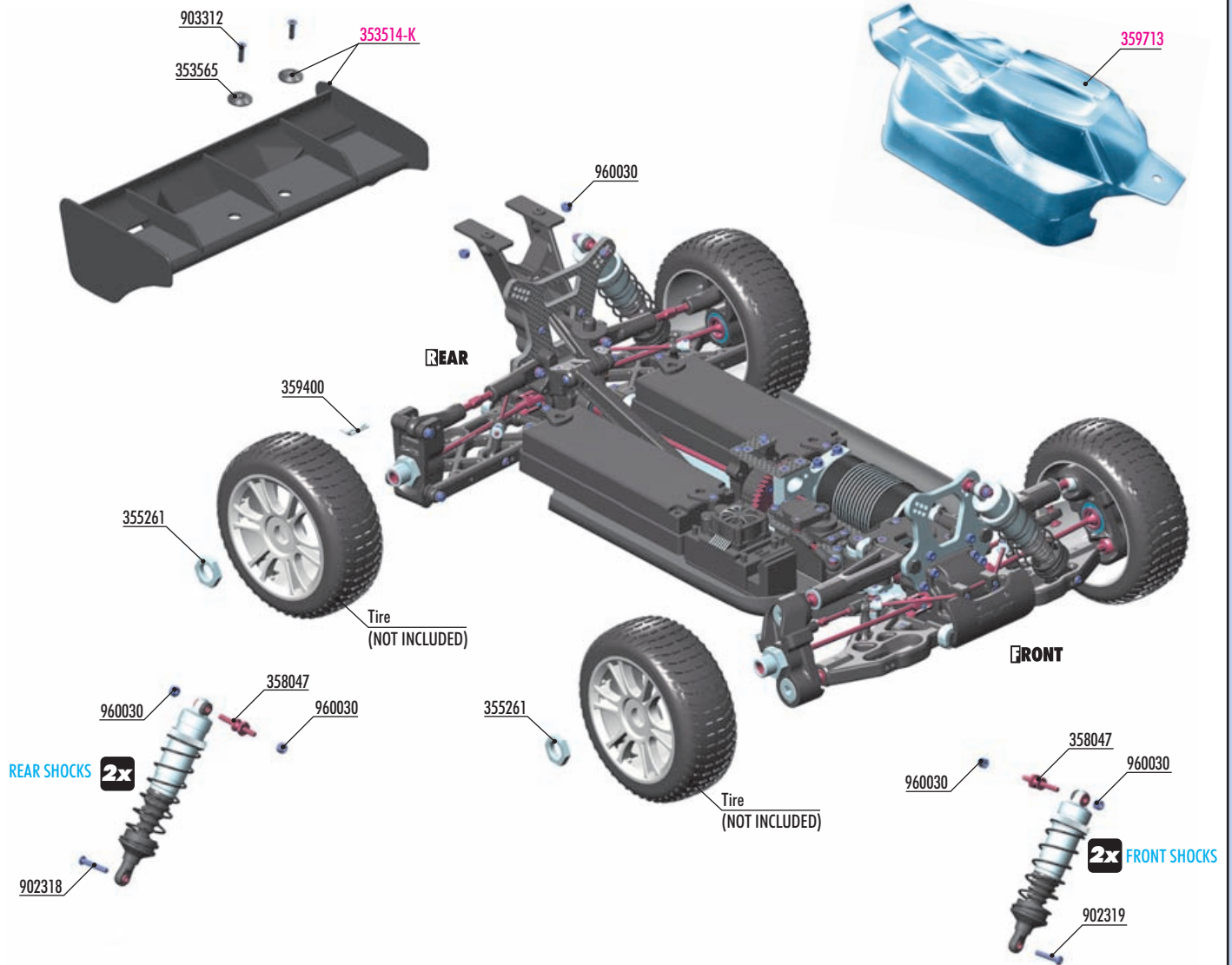

XRAY STARBURST WHEELS			
OPTION	#359808	Pink	OPTION
	#359809	Yellow	OPTION

WHEEL NUTS			
OPTION	#355261	OPEN	INCLUDED
	#293560	COVERED	OPTION
	#355265	COVERED	OPTION

HUDY REAR WING SHIM			
OPTION	#293561	SILVER	OPTION
	#293561-O	ORANGE	OPTION
	#293561-K	BLACK	OPTION
	#353561	SILVER	OPTION

WINGS			
OPTION	#353514-K	BLACK	INCLUDED
	#353514	WHITE	OPTION
	#353514-Y	YELLOW	OPTION
	#353512	LEXAN®	OPTION

XB8 BODIES			
OPTION	#359711	HIGH-SPEED	OPTION
	#359712	HIGH-SPEED LIGHTWEIGHT	OPTION
	#359713	"EAZY"	INCLUDED
	#359714	"EAZY" LIGHTWEIGHT	OPTION



- 353565 COMPOSITE REAR WING SHIM - BLACK (2)
- 355261 WHEEL NUT - RIBBED - HARD COATED (2)
- 358047 STEEL SCREW SHOCK PIVOT BALL WITH HEX (2)
- 359400 BODY CLIP (10)
- 902318 HEX SCREW SH M3x18 (10)
- 902319 HEX SCREW SH M3x18 - LEFT THREAD (10)
- 903312 HEX SCREW SFH M3x12 (10)
- 960030 NUT M3 (10)

- 353514-K REAR WING - FRONTWARD - BLACK
- 359713 XRAY XB8 / XB8E "EAZY" BODY

12. FINAL ASSEMBLY

FRONT SHOCKS (SHORT)

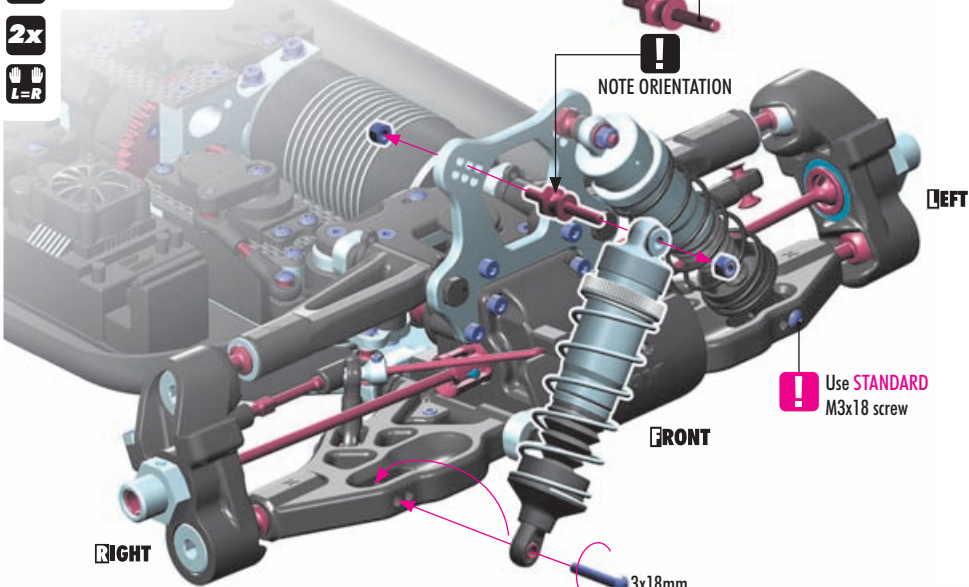
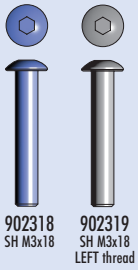

Use **STANDARD** M3x18 screw

On the front right arm use the **SILVER** M3x18 screw - this screw has **LEFT THREAD**.



SET-UP BOOK
SHOCK ABSORBERS

REAR SHOCKS (LONG)

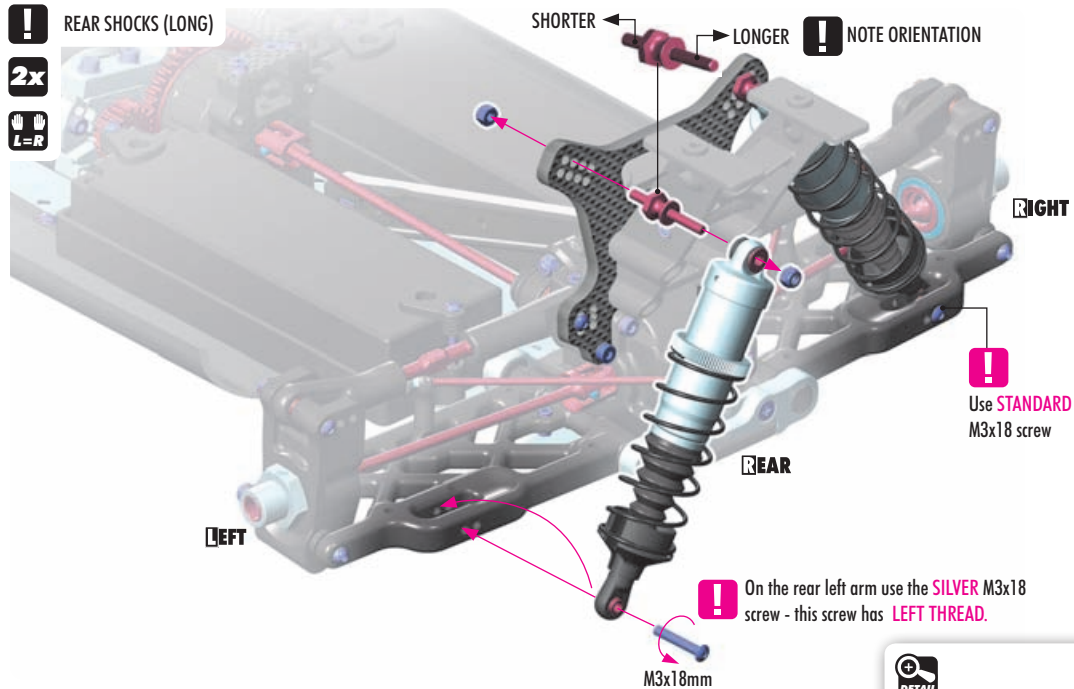
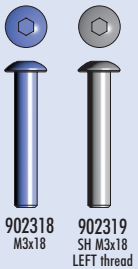

Use **STANDARD** M3x18 screw

On the rear left arm use the **SILVER** M3x18 screw - this screw has **LEFT THREAD**.

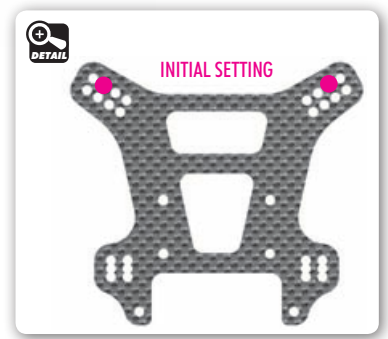
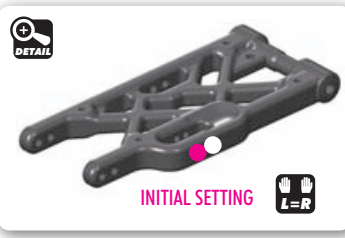

SET-UP BOOK
SHOCK ABSORBERS

12. FINAL ASSEMBLY

- 1 Before cutting and making holes on the body, put the unpainted body on the chassis to confirm the mounting position and location for holes and cutouts.
- 2 Before painting, wash the inside of the body with mild detergent, and then rinse and dry thoroughly.
- 3 Mask all windows.
- 4 Apply paint masks as appropriate.

- 5 Paint the body using paints formulated for polycarbonate bodies.
- 6 When the paint is dry, remove the masking.
- 7 Carefully cut out the body using appropriate scissors or cutting tools.
- 8 When you have finished cutting, peel off the external protective films.

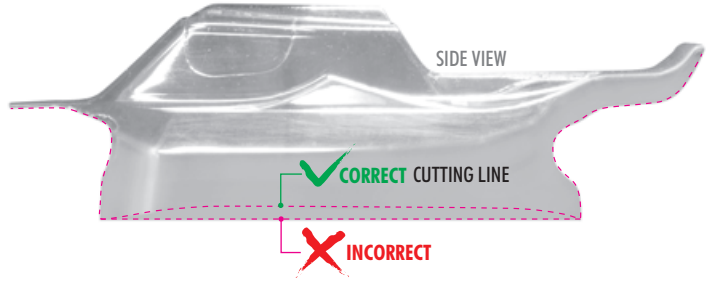
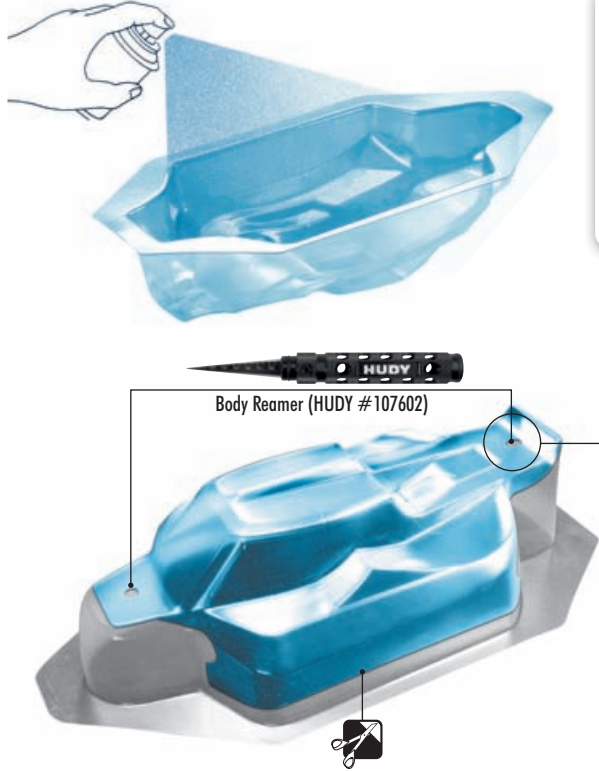

X88 BODIES			
OPTION	#359711	HIGH-SPEED	OPTION
	#359712	HIGH-SPEED LIGHTWEIGHT	OPTION
	#359713	"EAZY"	INCLUDED
	#359714	"EAZY" LIGHTWEIGHT	OPTION

- 903312 SFH M3x12
- 960030 N M3

WINGS			
OPTION	#353514-K	BLACK	INCLUDED
	#353514	WHITE	OPTION
	#353514-Y	YELLOW	OPTION
	#353512	LEXAN®	OPTION

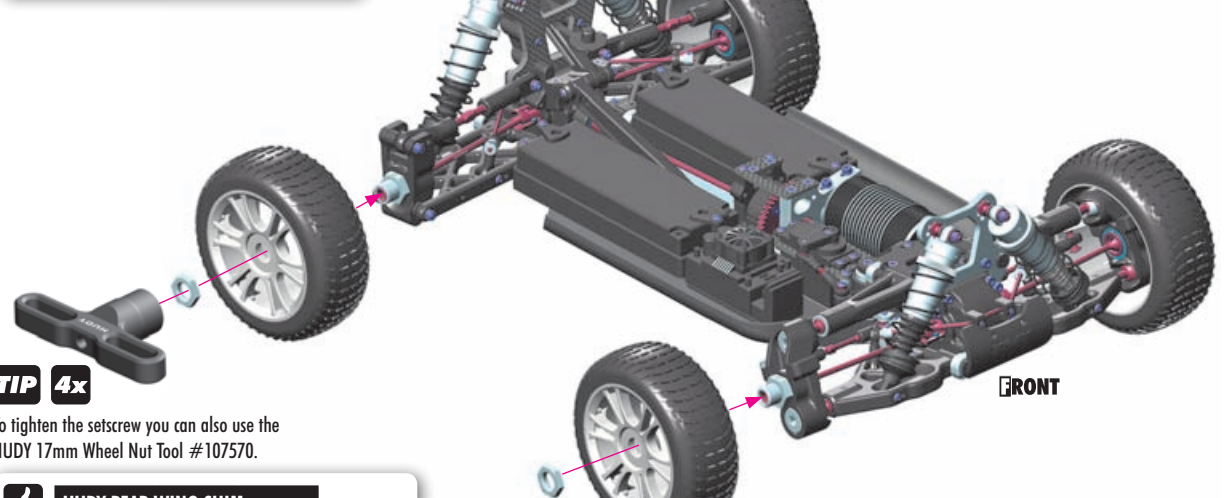

TIP 4x
To tighten the setscrew you can also use the HUDY 17mm Wheel Nut Tool #107570.

HUDY REAR WING SHIM			
OPTION	#293561	SILVER	OPTION
	#293561-O	ORANGE	OPTION
	#293561-K	BLACK	OPTION
	#353561	SILVER	OPTION

WHEEL NUTS			
OPTION	#355261	OPEN	INCLUDED
	#293560	COVERED	OPTION
	#355265	COVERED	OPTION

XRAY STARBURST WHEELS			
OPTION	#359808	Pink	OPTION
	#359809	Yellow	OPTION

FRONT C-HUB SUSPENSION



#350907 XB8/XB8E FRONT C-HUB SUSPENSION - SET

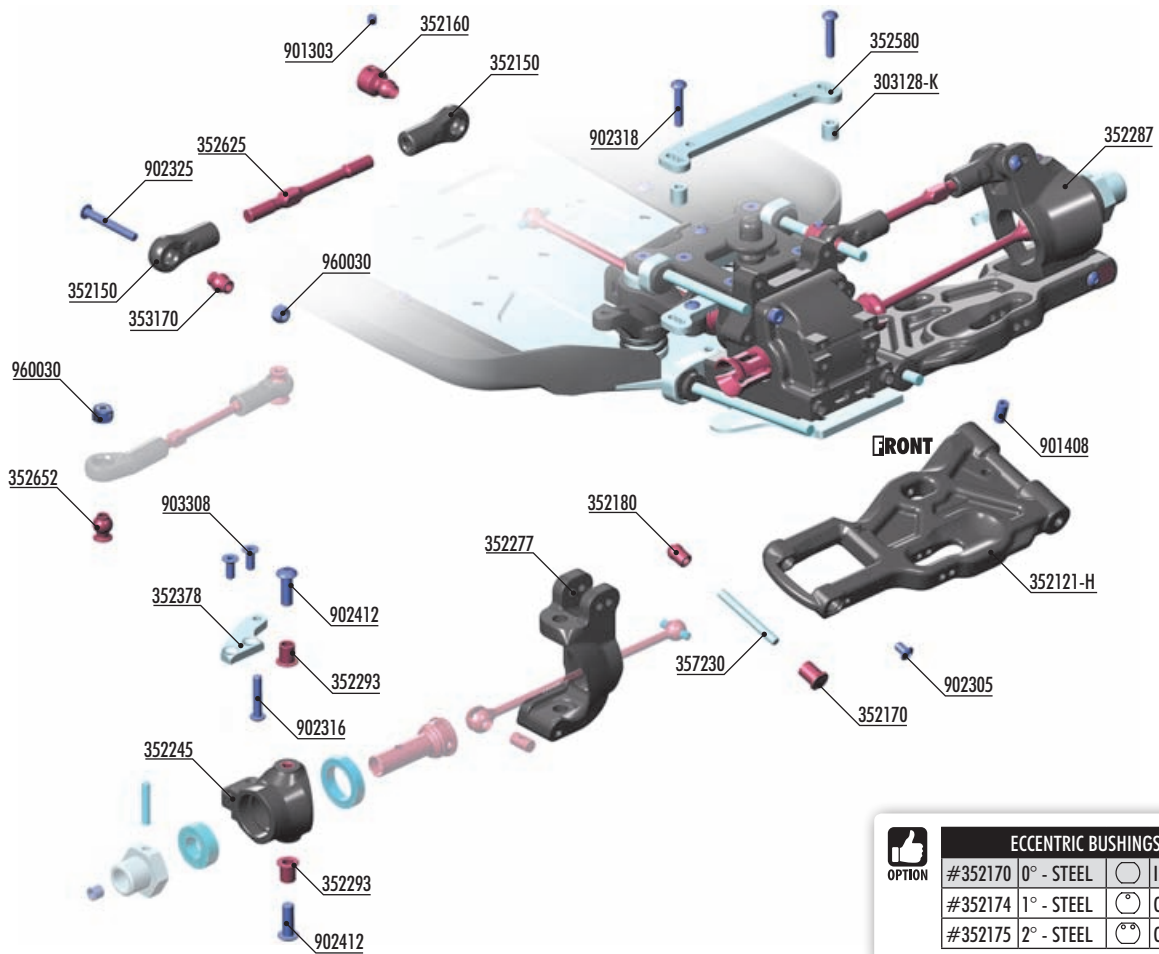

ECCENTRIC BUSHINGS			
	OPTION	#352170 0° - STEEL	INCLUDED
		#352174 1° - STEEL	OPTION
		#352175 2° - STEEL	OPTION

- 303128-K ALU SHIM 3x6x6MM (10)
- 352121-H COMPOSITE FRONT LOWER SUSPENSION ARM - HARD
- 352150 FRONT UPPER ARM BALL JOINT (2)
- 352160 STEEL MOUNTING BALL 6.8MM (2)
- 352170 STEEL ECCENTRIC BUSHING 0° (2)
- 352180 BALL MOUNT (2)
- 352245 STEERING BLOCK
- 352277 COMPOSITE CASTER BLOCK 16° RIGHT
- 352287 COMPOSITE CASTER BLOCK 16° LEFT

- 352293 STEEL BUSHING FOR CASTER BLOCK (2)
- 352378 ALU STEERING PLATE - SWISS 7075 T6 (L+R)
- 352580 ALU STEERING PLATE - SWISS 7075 T6
- 352625 ADJ. TURNBUCKLE M5 L/R 46mm (2)
- 352652 BALL STUD 6.8MM (4)
- 353170 PIVOT BALL 6.8 (4)
- 357230 FRONT LOWER OUTER PIVOT PIN (2)

- 901303 HEX SCREW SB M3x3 (10)
- 901408 HEX SCREW SB M4x8 (10)
- 902305 HEX SCREW SH M3x5 (10)
- 902316 HEX SCREW SH M3x16 (10)
- 902318 HEX SCREW SH M3x18 (10)
- 902325 HEX SCREW SH M3x25 (10)
- 902412 HEX SCREW SH M4x12 (10)
- 903308 HEX SCREW SFH M3x8 (10)
- 960030 NUT M3 (10)

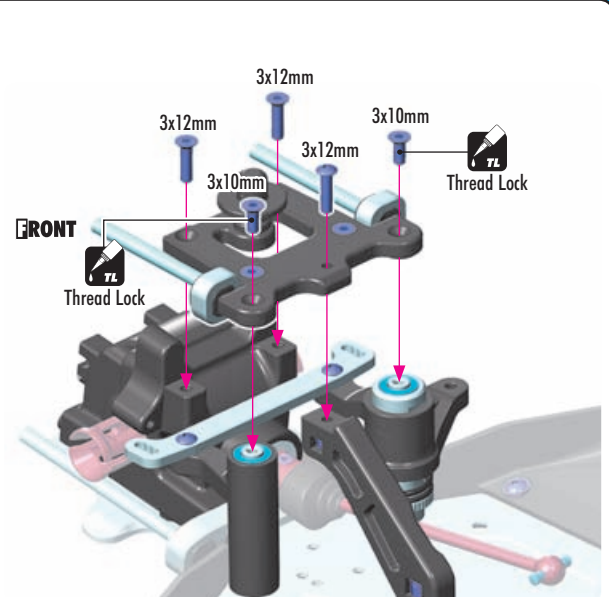
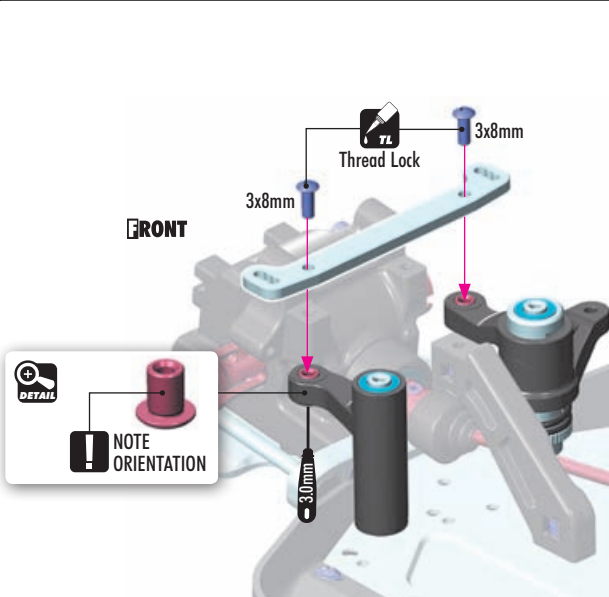
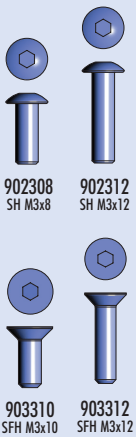

FRONT C-HUB SUSPENSION

941318
BB 13x19x4

940816
BB 8x16x5

901504
SB M5x4

903308
SFH M3x8

980317
P 3x17

2x **L=R**

NOTE ORIENTATION

8x16x5

13x19x4

TIP Use HUDY Ball-Bearing Grease for servicing:
#106220 - Standard
#106221 - Extra
#106222 - Premium

TIP Graphite Grease (HUDY #106210)

TIP To tighten the setscrew you can also use the HUDY 17mm Wheel Nut Tool #107570.

902412
SH M4x12

2x **L=R**

SHORT ①

LONG ①

Marked "R"

2x **L=R**

LEFT THREAD

RIGHT THREAD

TIP Install the pivot balls with Professional Multi-Tool (HUDY #183011).

21.5mm

LEFT

RIGHT

901408
SB M4x8

902305
SH M3x5

902325
SH M3x25

960030
N M3

2x **L=R**

NOTE ORIENTATION

STEP ① DETAIL

TIP Press pivot ball into arm until it snaps into place.

TIP DOWNSTOP SETTING

STEP ⑦ DETAIL **TOP** 0.0mm **BOTTOM**

ECCENTRIC BUSHINGS			
OPTION #352170	0° - STEEL		INCLUDED
#352174	1° - STEEL		OPTION
#352175	2° - STEEL		OPTION

FRONT C-HUB SUSPENSION



901303
SB M3x3



909395
SS 3.5x45

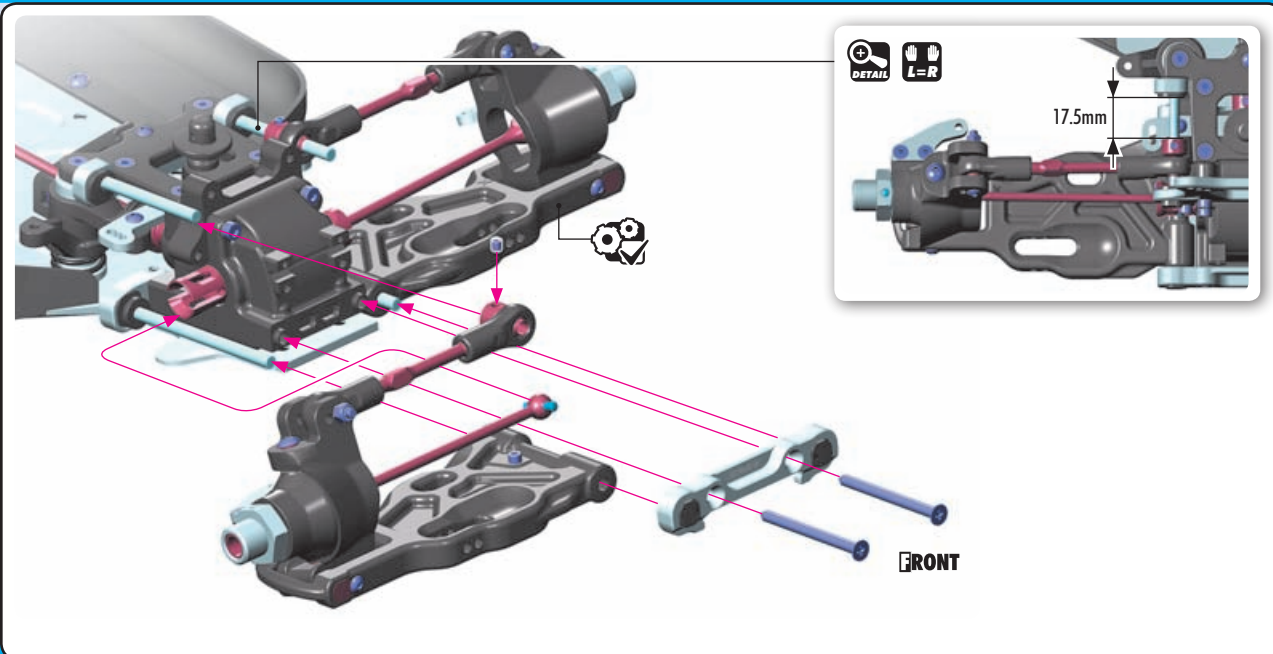

908312
SCH M3x12

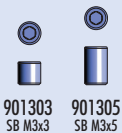
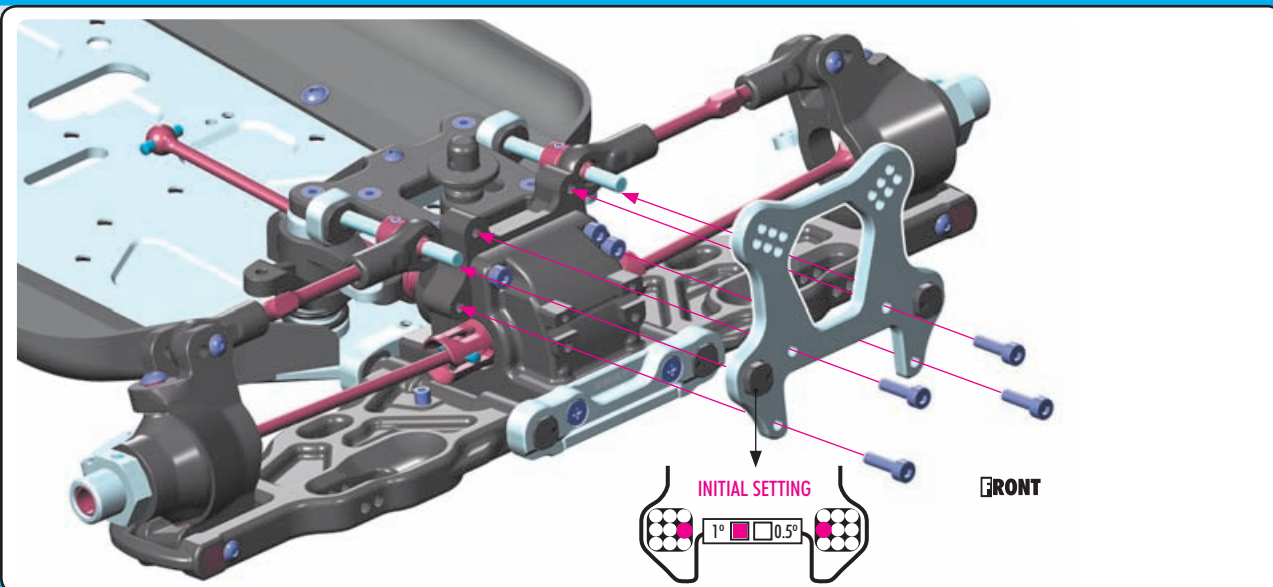

901303
SB M3x3

901305
SB M3x5



902318
SFH M3x18

903308
SFH M3x8



903412
SFH M4x12

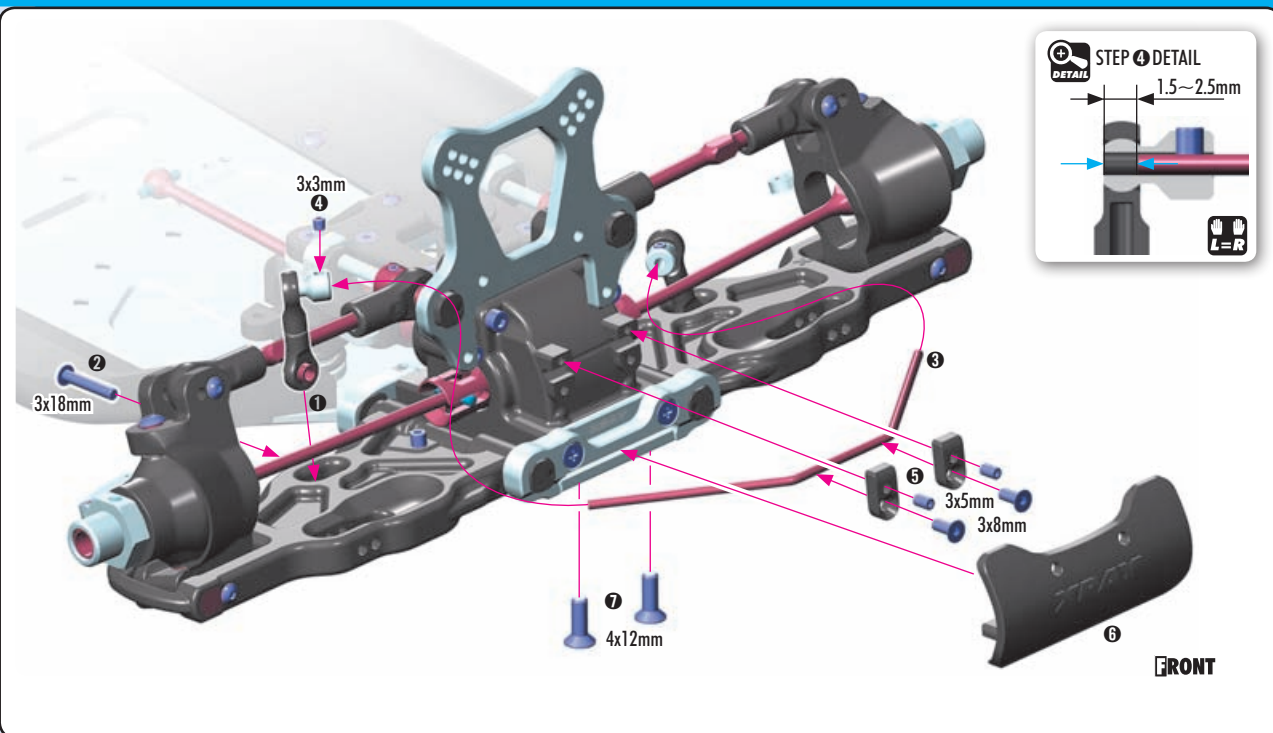

FRONT C-HUB SUSPENSION

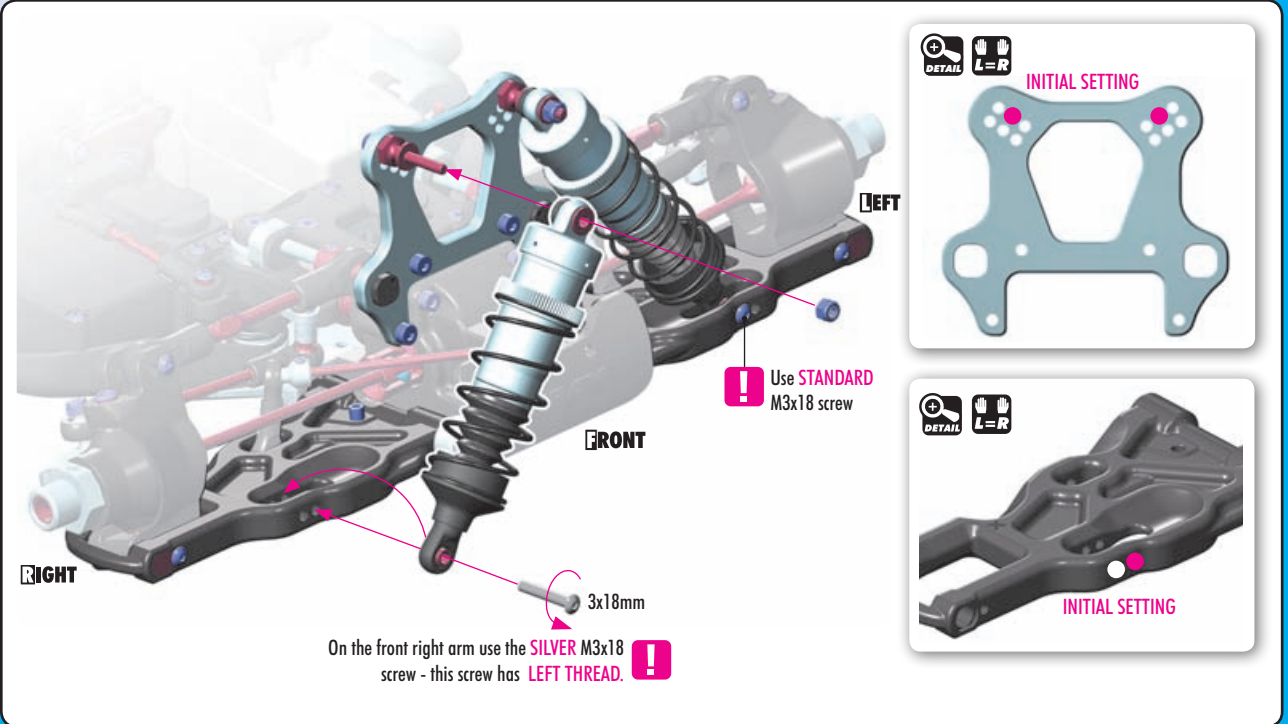
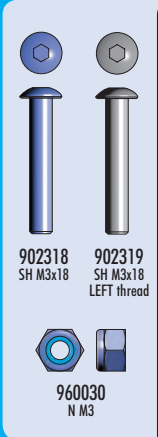
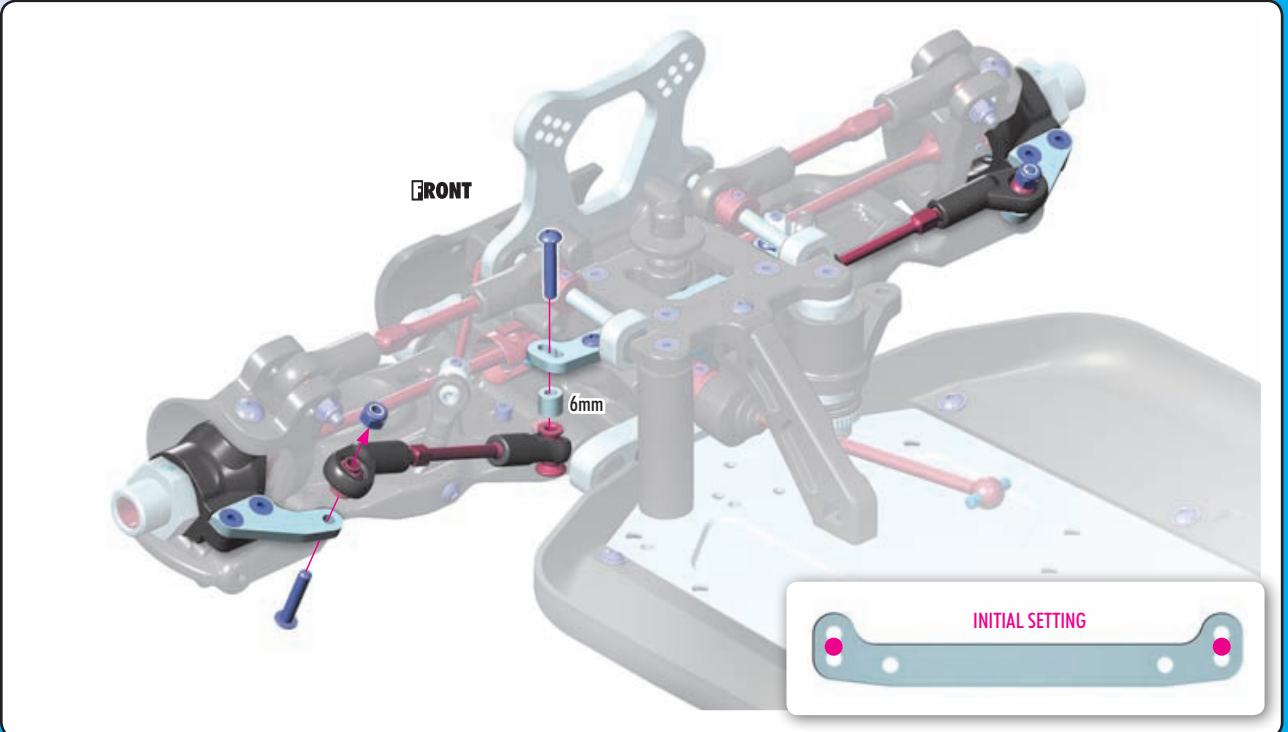
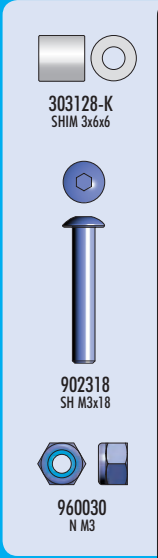
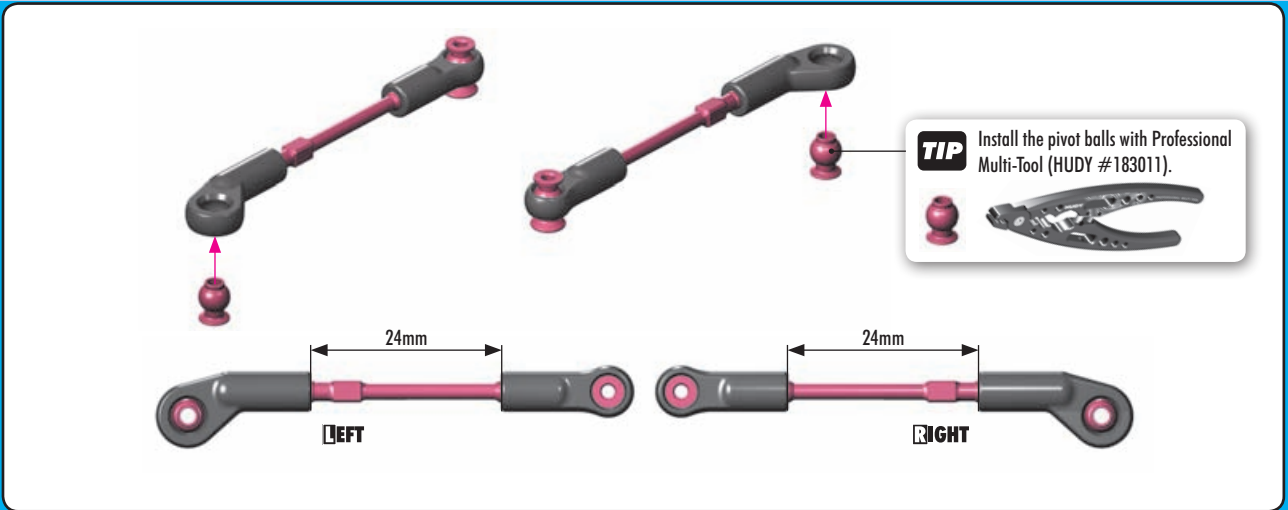

SHOCK MAINTENANCE

The most important maintenance task for keeping consistent shock performance is refilling and bleeding them correctly. If built correctly, it will not be necessary to re-build them often. Replacing warped/hard rubber bladders and o-rings, scarred piston rods, or shaved/split/loose composite upper and lower ball joints are also important.

- For club racing, it is recommended to check the shocks for air inside before each race and only re-fill and bleed them if necessary. Before each race day, make sure you take the spring off of each shock, hold it up to your ear, and quickly compress the shock rod fully into the body while listening for any air making a "whistling" or "squishy" sound as it passes through the piston holes. If you hear any air, refill and bleed your shocks. For high-competition racing, it is recommended that the shocks be re-filled and bled before a large event.
- If building or pairing new shocks, always make sure they are the same length using a shock length measuring tool and adjust the lower ball joints as needed.
- If installing new rubber bladders, carefully trim the thin excess rubber from the edges of their lips. Curved body scissors work the best.
- Regularly inspect the amount of dirt on the felt protector in the shocks (if present) and regularly replace with a new one.
- During regular shock operation, oil naturally gets on the shock shaft and drop-by-drop slightly gets out of the shock body. Shocks should be inspected regularly after each race, and oil replaced as required.

BEARING MAINTENANCE

Ball-bearings in an off-road car or truggy must be properly maintained for smooth operation and long lifespan.

Typically, the ball-bearings included in new cars are greased for highest lifespan and as such the drivetrain may not seem to be as free as with lightly-oiled ball-bearings. However, when the car is run the ball-bearings will become more free and the drivetrain will become very efficient.

There are several types of bearings discussed here: bearings which already come greased from the factory, bearings which must be lubricated using the HUDY Bearing Grease, and then there are also bearings in the steering system which need to be lubricated with HUDY Bearing Oil.

The following procedures are recommended to clean all of the bearings in your off-road car or truggy. For high-competition racing, we recommended doing this every 3-4 weeks, or before a major race.

1. Remove the seals on both sides of the bearing (if present). If the seals bend a little and you can see a kink, carefully flatten the kink out by hand.
2. Spray the seals with motor cleaner and blow dry with compressed air.
3. Spray the bearing on both sides with motor cleaner.
4. Spin the bearing while it is still wet to dislodge any particles with the cleaner.
5. Spray the bearing on both sides again.
6. Blow both sides of the bearing dry with compressed air to make sure particles come out.
7. Hold the inner part of the bearing with my left thumb/forefinger and spin it to make sure it spins free without any abnormal vibrations or sounds.
8. Place one drop of bearing oil into each side of the bearing.
9. Replace both seals at the same time by lining them up on each side of the bearing and lightly pressing them in all the way around the bearings circumference with your thumb and forefinger. Do not press too hard or use any type of tool, such as a wrench tip, to push the blue seals in as they will push in too far, bend and cause drag.

If you spin test the bearing after you have re-oiled and sealed it, it will not spin freely for an extended period of time. The lightest of oils may allow it to spin for 1-2 seconds. This is normal and once you have mounted the bearings in the car again, the drive train will spin freely.

Make sure you use a motor cleaner that does not leave a residue after it dries as this may cause drag and wear in the bearings.

CLUTCH BEARINGS

To prolong the lifespan of the clutch bearings, they must be regularly cleaned and lubricated (preferably after each run) using a high-quality grease such as HUDY Bearing Grease. However, after some time the clutch bearings must be replaced with new ones.

RECOMMENDED PRODUCTS

- Use HUDY Bearing Grease to regularly lubricate grease-bearing ball-bearings.
- Use HUDY Bearing Oil to lubricate the bearings of the steering system.
- Use HUDY Bearing Grease to regularly lubricate the clutch bearings.



HUDY

All the tools & accessories shown are suitable for XB8 and/or XB8E

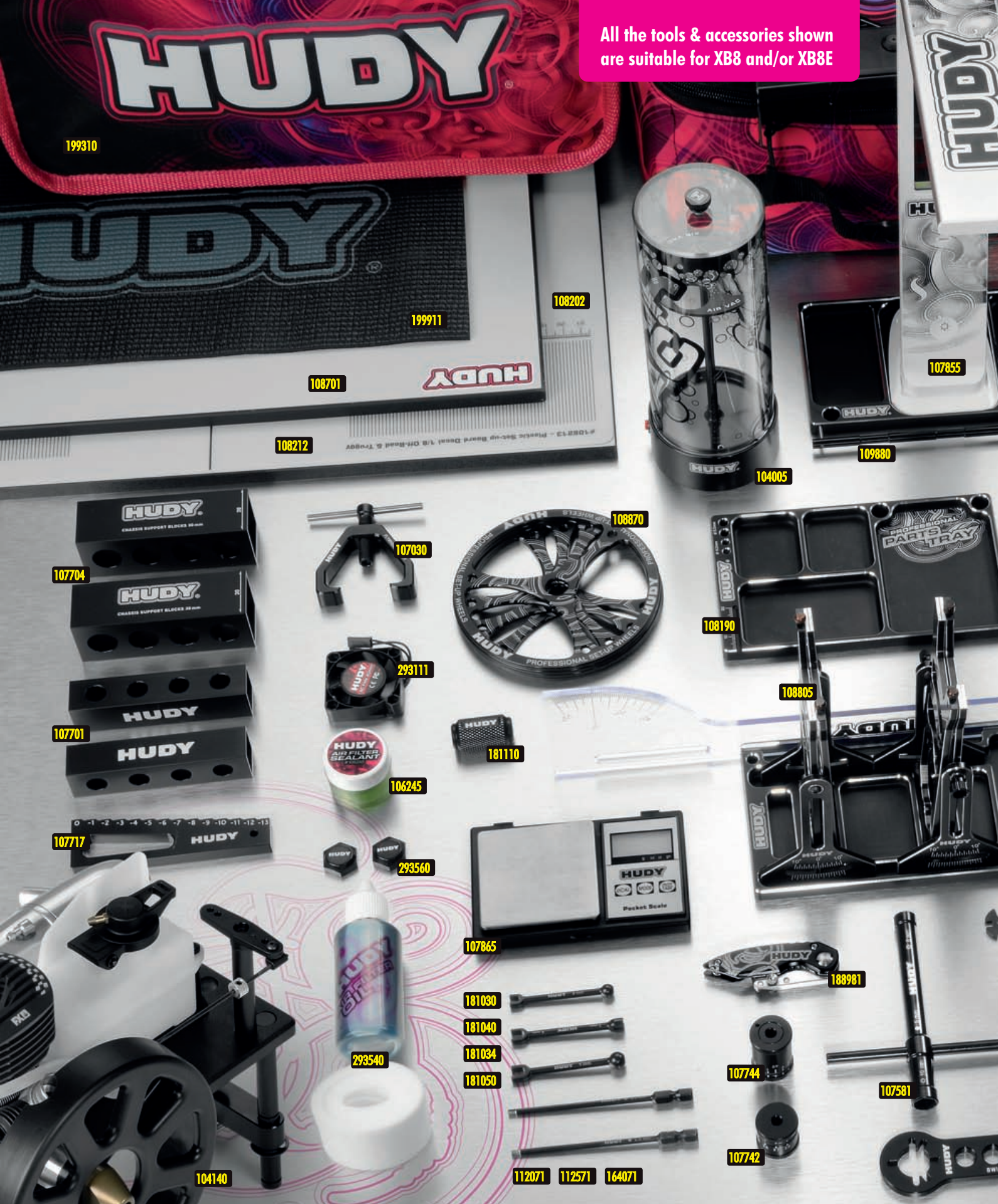

- #104005 HUDY Air Vac - Vacuum Pump - 1/8 Off-Road
- #104140 HUDY Engine Break-In Bench
- #104500 HUDY Star-Box 1/8 Off-Road
- #105500 HUDY Universal Tire Balancing Station
- #105510 Wheel Adapter for 1/8 Off-Road Cars, Truggy & Rally Game
- #106000 HUDY Drive Pin Replacement Tool (for 3mm Pins)
- #106200 HUDY Magic Cleaning Gum
- #106245 HUDY Air Filter Sealant
- #107030 HUDY Flywheel Puller
- #107090 HUDY Bearing Check Tool
- #107570 HUDY 17mm Off-Road Wheel Nut Tool
- #107581 HUDY Cross Wrench Glowplug # 8mm / Clutchnut # 10mm
- #107602 Limited Edition - Reamer for Body 0-18mm + Cover - Large

- #107612 Limited Edition - Exhaust Spring / Caster Clip Remover
- #107644 Limited Edition - Arm Reamer # 4.0mm
- #107701 Chassis Droop Gauge Support Blocks 20mm for 1/8 - LW(2)
- #107704 Chassis Droop Gauge Support Blocks 30mm 1/8 Off-Road - LW (2)
- #107717 Chassis Droop Gauge 0 to -13 mm for 1/8 Off-Road
- #107742 HUDY Adjustable Ride Height Gauge 20-30mm
- #107744 HUDY Adjustable Ride Height Gauge 30-45mm
- #107762 HUDY Adjustable Camber Gauge 110mm
- #107780 HUDY Adjustable Droop Gauge 80-140mm
- #107783 HUDY Droop Gauge 70-140mm
- #107855 HUDY Pit LED
- #107865 HUDY Ultimate Digital Pocket Scale 300g/0.01g
- #108170 HUDY Off-Road & Truggy Car Stand

- #108190 HUDY Alu Tray for Parts
- #108202 Flat Set-Up Board for 1/8 Off-Road & Truggy
- #108212 Plastic Set-up Board Decal for 1/8 Off-Road & Truggy
- #108701 Flat Set-Up Board for 1/8 Off-Road & GT - Lightweight
- #108805 Universal Exclusive Set-up System for 1/8 Off-Road Cars
- #108841 Upside Measure Plate for 1/8 Truggy
- #108860 Alu Nut for 1/8 Off-Road System (4)
- #108870 Alu Set-up Wheel for 1/8 Off-Road Cars - V2 (4)
- #109802 HUDY Alu Tray for 1/8 Off-Road Diff & Shocks
- #109841 HUDY Alu Tray for 1/8 Off-Road Diff Assembly
- #109860 HUDY Alu Tray for Set-Up System
- #109880 HUDY Alu Tray for Accessories & Pit LED
- #111545 Limited Edition - Allen Wrench # 1.5mm

EXCLUSIVE PROFESSIONAL

HUDY



- #112045 Limited Edition - Allen Wrench # 2.0mm
- #112071 Power Tool Tip Allen 2.0 x 90 mm
- #112545 Limited Edition - Allen Wrench # 2.5mm
- #112571 Power Tool Tip Allen 2.5 x 90 mm
- #113045 Limited Edition - Allen Wrench # 3.0mm
- #132045 Limited Edition - Allen Wrench + Ball Repl. Tip # 2.0mm
- #132545 Limited Edition - Allen Wrench + Ball Repl. Tip # 2.5mm
- #154060 Long Slotted Screwdriver 4.0 mm - for Engine Adjust. - SPC - V2
- #164045 Limited Edition - Phillips Screwdriver # 4.0mm
- #164071 Power Tool Tip Phillips 4.0 x 90 mm
- #170050 Socket Driver 5.0 mm
- #175535 Limited Edition - Socket Driver # 5.5mm
- #181030 HUDY Spring Steel Turnbuckle Wrench 3 mm

- #181034 HUDY Spring Steel Turnbuckle Wrench 3 & 4mm
- #181040 HUDY Spring Steel Turnbuckle Wrench 4 mm
- #181050 HUDY Spring Steel Turnbuckle Wrench 5 mm
- #181090 HUDY Special Tool For Turnbuckles & Nuts
- #181110 HUDY Ball Joint Wrench
- #182015 HUDY 1/8 Off-Road Flywheel/Wheel Nut Multi-Tool
- #183011 HUDY Professional Multi Tool
- #188981 HUDY Pocket Hobby Knife
- #188990 HUDY Professional Body Scissors
- #199060 HUDY Alu Tool Stand
- #199184 HUDY Car Bag - 1/8 & 1/10 Off-Road
- #199270 HUDY LiPo Safety Bag
- #199310 HUDY Pit Bag - Compact

- #199911 HUDY Pit Mat Roll 750x1200mm with Printing
- #293111 HUDY Brushless RC Fan 40mm
- #293540 Air Filter Foam & Oil (10) - XRAY XB8 Low Profile Style
- #293560 HUDY Alu Wheel Nut with Cover - Ribbed (2)

For more information about tools, set-up equipment and accessories suitable for your car please visit:

www.hudy.net



www.teamxray.com

XRAY EUROPE

XRAY, K VÝSTAVISKU 6992, 91101 TRENCIN, SLOVAKIA, EUROPE
PHONE: +421-32-740 11 00, FAX: +421-32-740 11 09, info@teamxray.com

XRAY USA

RC AMERICA, 2030 Century Center Blvd #15, Irving, TX 75062, USA
PHONE: 214-744-2400, FAX: 214-744-2401, xray@rcamerica.com



[/TeamXray](#)



[/TeamXray](#)



[/TeamXray](#)



[/TeamXrayRC](#)



[/XrayRacing](#)



[/XrayRacing](#)