

FIND IT ON ASSOCIATEDELECTRICS.COM



Vehicle Spare Parts

GO TO:

- AssociatedElectrics.com →
- Team Associated tab →
- Cars & Trucks →
- Scroll to your vehicle →
- Parts & Accessories link



Setups and Manuals

GO TO:

- AssociatedElectrics.com →
- Team Associated tab →
- Manuals & Setups →
- Scroll to your vehicle



Tuning Guides & Tips

GO TO:

- AssociatedElectrics.com →
- Support →
- A-Team Apps



Associated Electrics, Inc.

21062 Bake Parkway Lake Forest, CA 92630 USA

call: (949) 544-7500 - fax: (949) 544-7501

**Check out the following web sites for all of our kits, current products,
new releases, setup help, tips, and racing info!**

www.AssociatedElectrics.com

FOLLOW US ON SOCIAL MEDIA



**TeamAssociated
ReedyPower
ElementRC**



**@TeamAssociatedRC
@ReedyPower
@Element_RC**



**@Team_Associated
@ReedyPower**



RIVAL

**1:10 Scale Ready-To-Run 4WD
Electric Off Road Monster Truck**

#20517 RIVAL MT10, Brushed, Ready-To-Run

SCALE	1:10	VEHICLE	RTR	READY TO RUN	4 WHEEL DRIVE	ELEC. POWERED	OFF ROAD	2.4GHz	PRE-POUNDED
-------	-------------	---------	------------	--------------	---------------	---------------	----------	--------	-------------

1:10 Scale Ready-To-Run 4WD Electric Off Road Monster Truck Manual



CHAMPIONS by DESIGN

AssociatedElectrics.com



:: Introduction

Thank you for purchasing this Team Associated product. This assembly manual contains instructions and tips for building and maintaining your new vehicle. Please take a moment to read through the manual and familiarize yourself with the steps. We are continually changing and improving our designs; therefore, actual parts may appear slightly different than the illustrations. New parts will be noted on supplementary sheets located in the appropriate parts bags. Check each bag for these sheets before you start to build.

:: Rival MT10 RTR Features

- 2.4GHz 2-channel radio system
- High-Torque Digital Servo with spring-style servo saver
- Reedy Sport 550 15T Brushed Motor
- Reedy Water-resistant brushed ESC with T-plug connector and LiPo low-voltage cutoff
- Three sealed gear differentials
- 12mm hex wheels inspired by Method Race Wheels
- Threaded Oil-filled coil over shock absorbers
- 4mm heavy-duty adjustable steel turnbuckles
- Durable slider type drive shafts
- Factory-finished RIVAL monster truck-inspired style body
- High-traction all terrain tires
- Steel center drive shaft
- Rugged adjustable wheelie bar
- Four-wheel independent suspension
- Durable, impact-absorbing front bumper

:: Table of Contents

1..... Cover	6 - 19.....Steps 1- 41
2..... Introduction	20.....Tuning Tips
3.....1:1 Hardware "Fold Out"	21.....Catalog
4 - 5..... Quick Start Guide	22..... Back Cover

:: Notes



There is a 1:1 hardware foldout page in the front of the manual. To check the size of a part, line up your hardware with the correct drawing until you find the exact size. Each part in the foldout has a number assigned to it for ordering replacement parts.



This symbol indicates a special note or instruction in the manual.

:: Additional

Your new Rival MT10 comes assembled. The following items are needed for completion.

- (4) AA batteries

Tools included: • 1.5mm, 2.0mm, 2.5mm Wrenches

:: Other Helpful Items

- Silicone Shock Fluid (Refer to catalog for complete listings)
- Silicone Diff Fluid (Refer to catalog for complete listings)
- Body Scissors (AE Part # 1737)
- Reamer / Hole Punch (#1499)
- Shock Pliers (#1675)
- Wire Cutters
- FT Hex/Nut Wrenches (AE Part # 1650)
- Needle Nose Pliers
- Hobby Knife
- Soldering Iron
- Calipers or a Precision Ruler
- Green Slime shock lube (AE Part # 1105)
- FT Turnbuckle Wrench (#1114)
- FT Universal Tire Balancer (#1498)















Associated Electrics, Inc.
21062 Bake Pkwy.
Lake Forest, CA 92630









Customer Service
Tel: 949.544.7500
Fax: 949.544.7501

:: Hardware - 1:1 Scale View



Button Head (bhcs)

	2.5x5mm (31519)
	2.5x6mm (31520)
	3x4mm (91158)
	3x6mm (31531)
	3x8mm (31532)
	3x10mm (25211) Aluminum (8554) Titanium (91582)
	3x12mm (89202) Titanium (91583)
	3x14mm (25187) Titanium (91584)
	3x16mm (89203) Titanium (91585)
	3x18mm (2308)
	3x20mm (25188) Titanium (91587)
	3x22mm (25189) Titanium (91588)
	3x38mm (25837)
	4x10mm (89206)
	4x14mm (81260)





Flat Head (fhcs)

	2.5x8mm (31448)
	2.5x10mm (31350)
	3x6mm (31541)
	3x12mm (25203) Aluminum (8556) Titanium (91594)
	3x14mm (89208) Aluminum (8567) Titanium (91595)
	3x18mm (89209) Titanium (91597)
	4x10mm (81262)



Set Screws

	3x3mm (25225)
	3x12mm (81258)
	4x12mm (25824)





Shims and Washers

	5.5x0.5mm (31381)
	5.5x1.0mm (31382)
	5.5x2.0mm (31383)
	3x8mm Washer (89218)







Socket Head (shcs)

	2x10mm (25801)
	2.5x6mm (41079)
	5x75mm (25837)

Ball Bearings

	5x8x2.5mm (8680)
	5x11x4mm (25618)
	10x15x4mm (91563)
	8x16x5mm (91564)
	12x18x4mm (25843)

Nuts (lock/plain)

	Plain M3 Nut (91477)
	M3 Alum. Locknut, Blue (31550)
	M3 Locknut, Black (25215)
	M4 Locknuts: Serrated Steel (Silver)(91826)
	FT Aluminum (Blue) (31551)
	Serrated Aluminum (Black) (91738)
	M5 Locknut w/Flange (25837)

Notes:

:: Quick Start Guide - (cont.)

Battery Charging and Safety:

Before charging your battery for the first time, please read the document Important Safety Instructions and Warnings found in the documents bad included with your vehicle.

Charging

1. To prepare the battery for charging, remove the battery from the vehicle and place it on a fire-proof surface [image 1] free from moisture and the potential for contact with water or any other liquids.
2. Plug the USB end of the charge cable into a 5V USB port [image 2].
Flashing red/green LED lights indicate the the charger is powered and is ready to use.
3. Plug the battery's 3-pin male connector into the charge cable's 3-pin female connector [image 3].
The red LED light will remain on to indicate that the battery is successfully charging.
4. The charge is complete when the red LED light goes out and the green LED illuminates.
5. Unplug the battery from the charger cable and then unplug the USB plug from USB port.
6. Your battery is now ready to use!

CAUTION! Failure to abide by the following may result in fire, property damage, and/or loss of life.

- Never leave the battery unattended while charging.
- Always remove the LiPo battery from the vehicle and place it on a fireproof surface while charging.
- Always disconnect the battery from the charge cord, and the charge cord from the USB port, when finished charging and when the charge cable is not in use.
- Always disconnect the battery from the vehicle when you are finished driving the vehicle and whenever the vehicle is not in use.
- Always store LiPo batteries in a fireproof container when not being used.
- Always use a charger specifically designed and engineered to charge LiPo batteries.

Image 1



Image 2

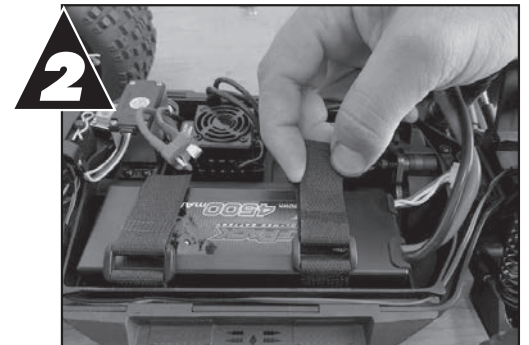
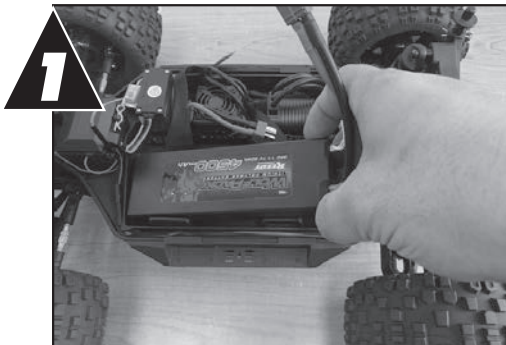

Image 3



Battery Installation:

1. Install the battery with the battery wires directed towards the rear of the vehicle.
2. Secure the battery strap using two hook and loop straps.



:: Quick Start Guide - (cont.)

Battery Notes and Tip:

Connect the battery as shown.
Disconnect the battery when not in use!

LiPo: LiPo batteries (lithium polymer) are high current rechargeable batteries. LiPo batteries offer extended run time and peak performance over NiMH batteries. They require a peak detection charger designed specifically for LiPo batteries. These batteries require special care and handling. LiPo batteries are recommended for advanced users only!
ALWAYS charge a LiPo battery in LiPo mode.

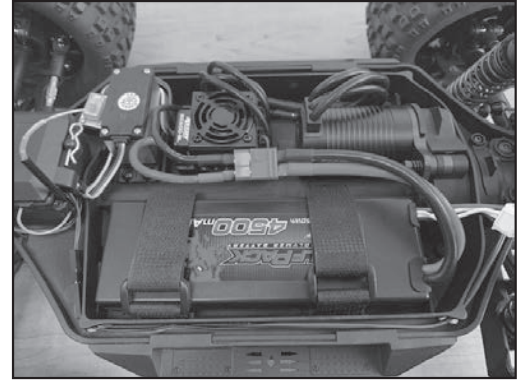

Radio System Tuning and Controls:

RULE:

Transmitter on First/Vehicle on Second,
Vehicle off First/ Transmitter off Last!

1. Slide the battery cover to remove cover.
2. Install alkaline or rechargeable AA size batteries into the battery holder.
3. Slide the battery cover back into place making sure it is completely closed and secure.
4. Turn the power ON. If the power indicator LED fails to light, check the batteries for insufficient contact or incorrect polarity.



On/Off Switch

:: Quick Start Guide - (cont.)

Radio System Tuning and Controls:

DO NOT hold the trigger when turning on the radio.

Refer to Radio owners manual for more in-depth instructions on radio operation and functions.

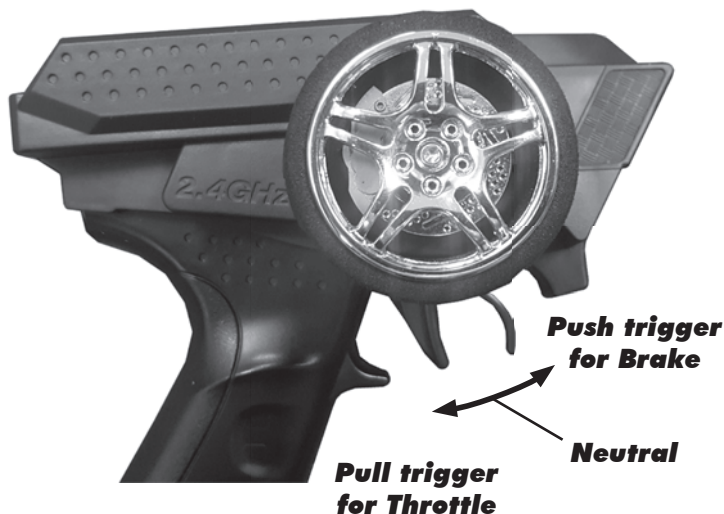

Throttle set to Neutral!



Adjust steering trim so front wheels point straight.



**Install body and body clips.
Ready to go!**

:: Step 1

25810 Sun Gear Shim
25810 Diff O-Ring
25810 Diff Output Shaft
25807 Diff Case (Front/Rear)

25810 Sun Gear Shim
25810 Diff O-Ring
25810 Diff Output Shaft
25808 Ring Gear, 37T

25810 Sun Gear
25810 Input Pin

25810 Sun Gear
25810 Input Pin

Build 2 (1 front, 1 rear)

:: Step 2

25810 $\times 4$ Planetary Gear
25810 $\times 2$ Diff Cross Pin
25810 $\times 4$ Planetary Gear Shim
25808 Diff Gasket
diff fluid

91563 $\times 2$ 10x15x4mm Bearing
31350 $\times 4$ 2.5x10mm FHCS

Front Diff Fluid: 60k cst #5458
Rear Diff Fluid: 3k cst #5452

:: Step 3

25812 Sun Gear Shim
25807 Diff Case (Center)
25812 Diff O-Ring
25812 Center Diff Shaft

25812 Sun Gear Shim
25811 Spur Gear (54T, 32P)
91564 8x16x5mm Bearing
25812 Center Diff Outdrive

25812 Center Diff Sun Gear
25812 Input Pin

25812 Center Diff Sun Gear
25812 Input Pin

Build 1 (1 center)

:: Step 4

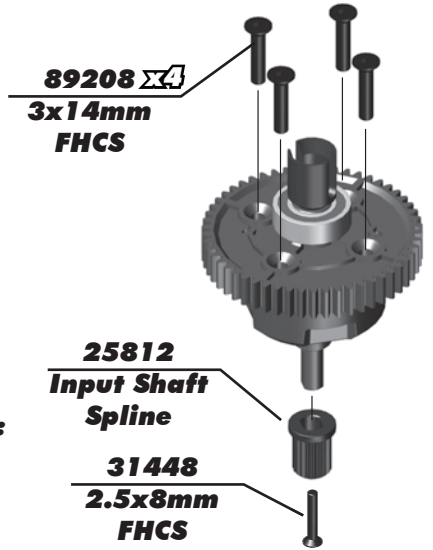
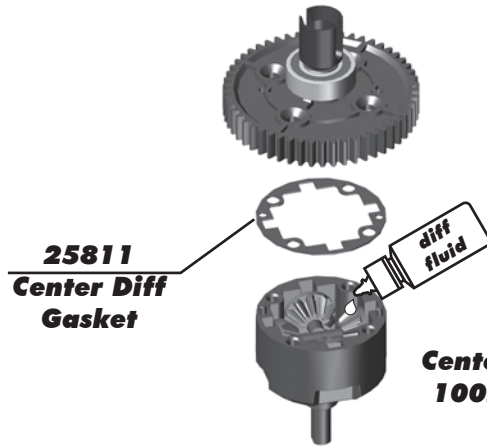
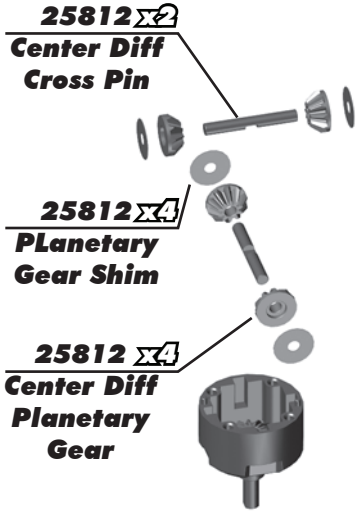

:: Step 5

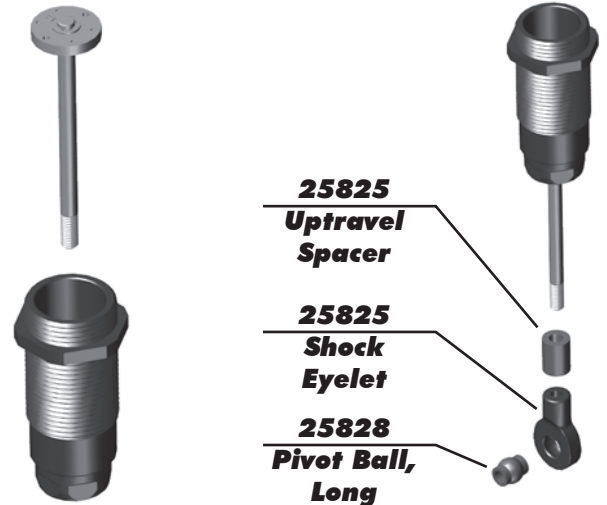
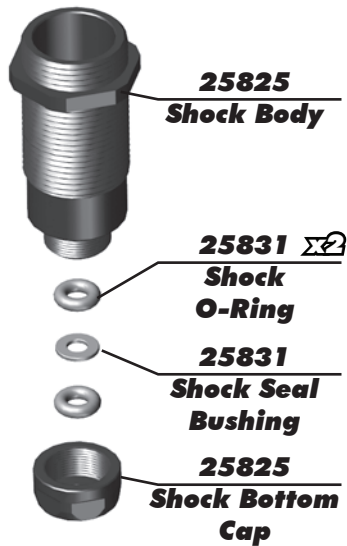
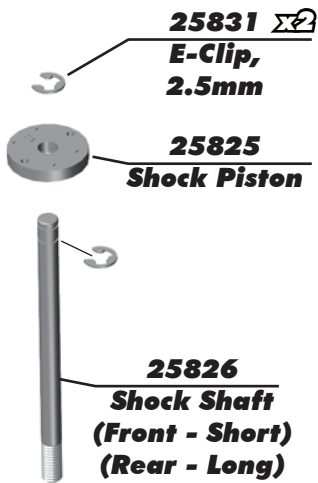

:: Step 6

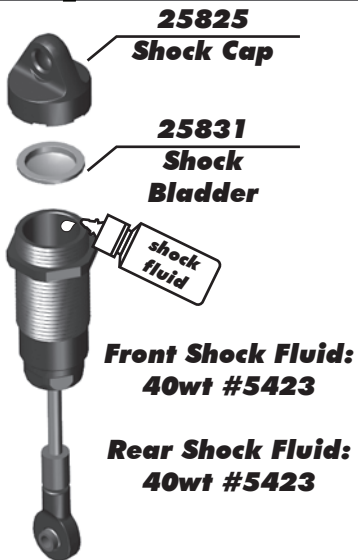

! Compress shock shaft half way. Let shock fluid bleed from cap, then tighten cap.

! For less rebound, compress shock shaft farther before tightening the shock cap.

! For more rebound, do not compress shock shaft as far before tightening the shock cap.

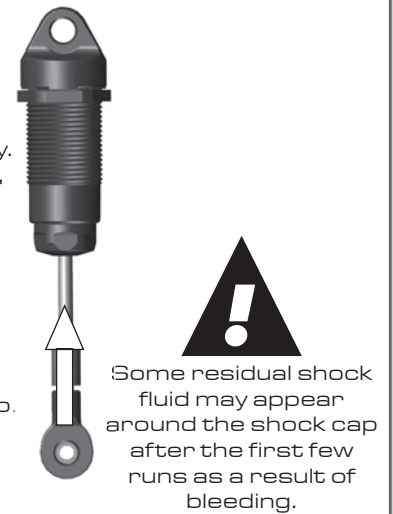

:: Step 7

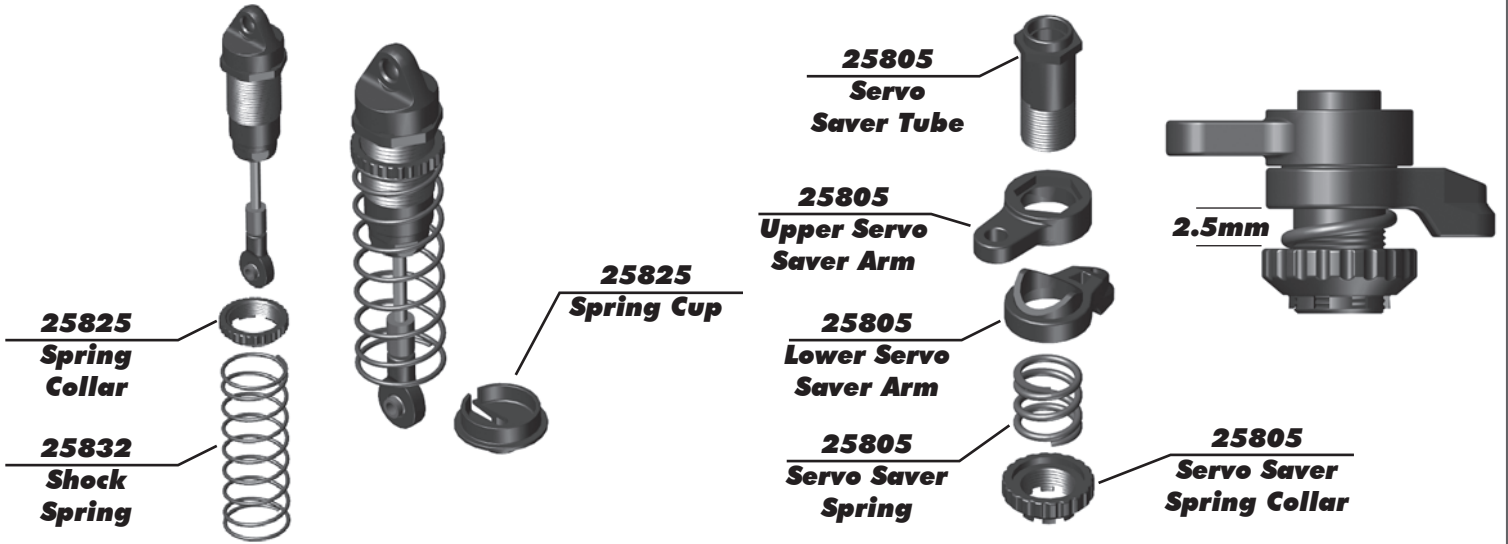

:: Step 8

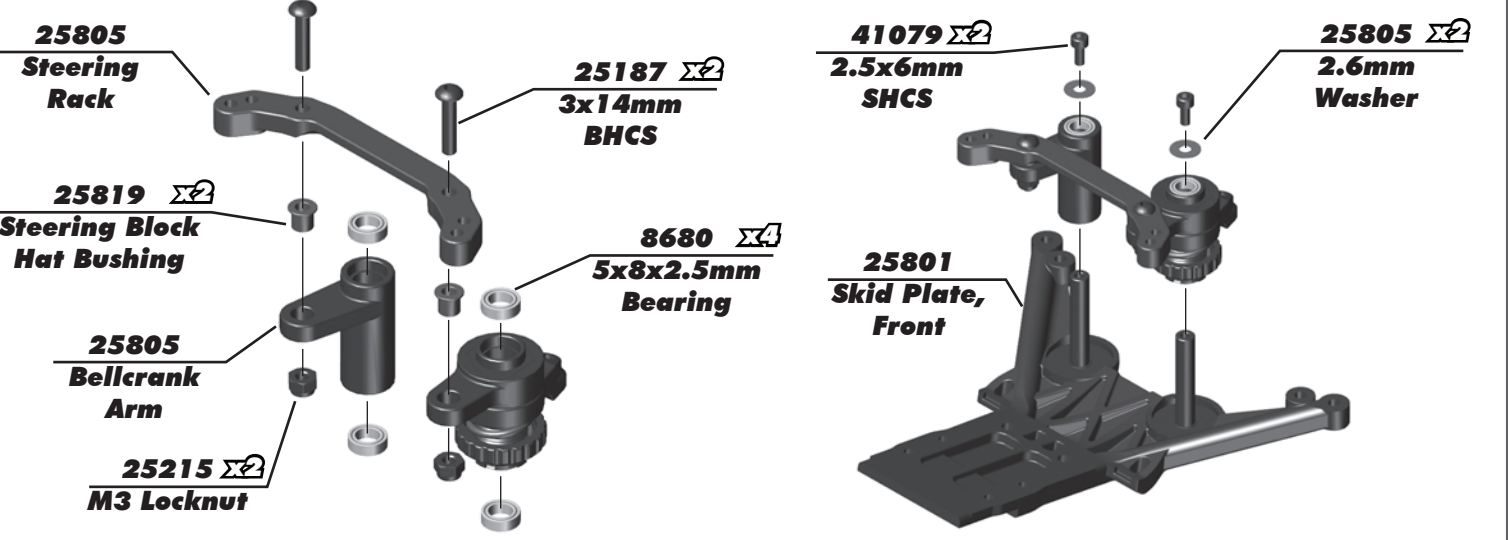

:: Step 9

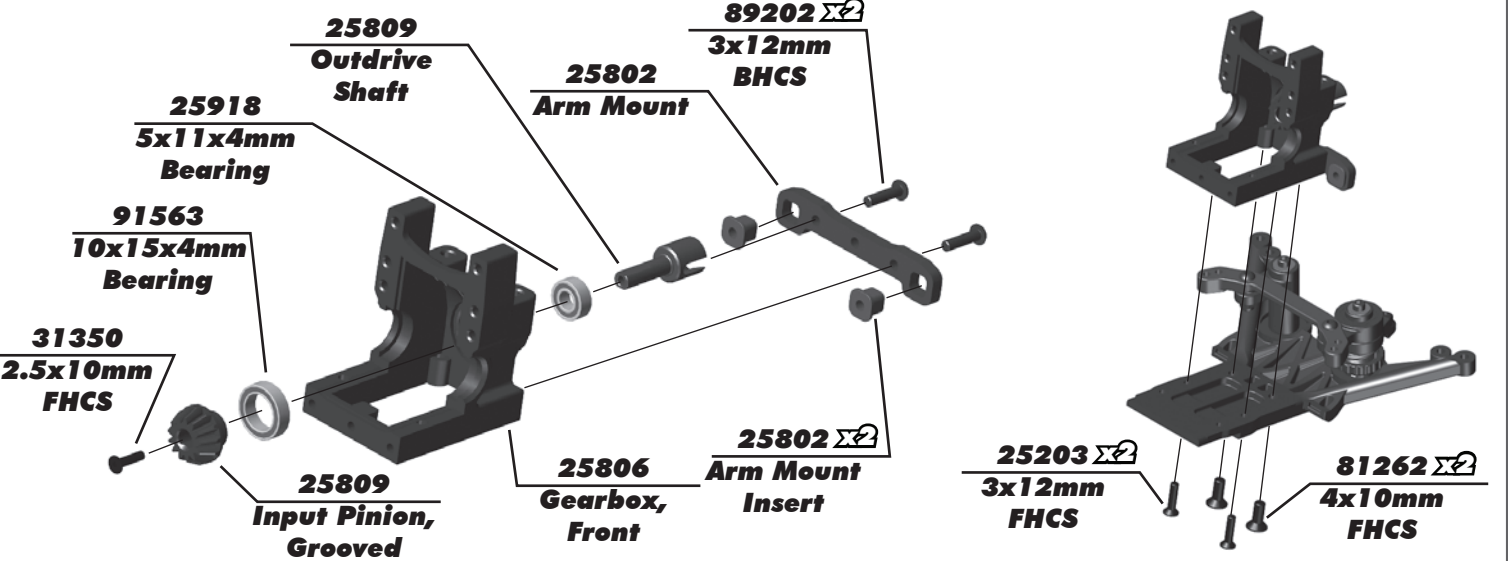

:: Step 10

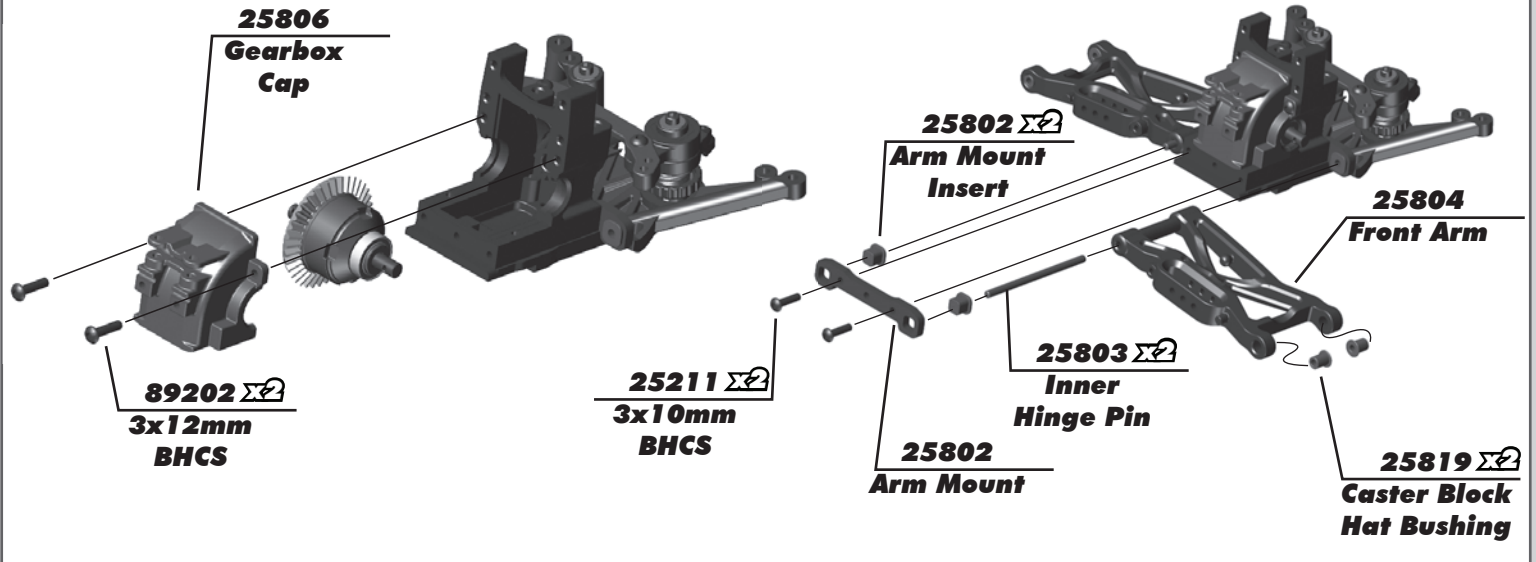

:: Step 11

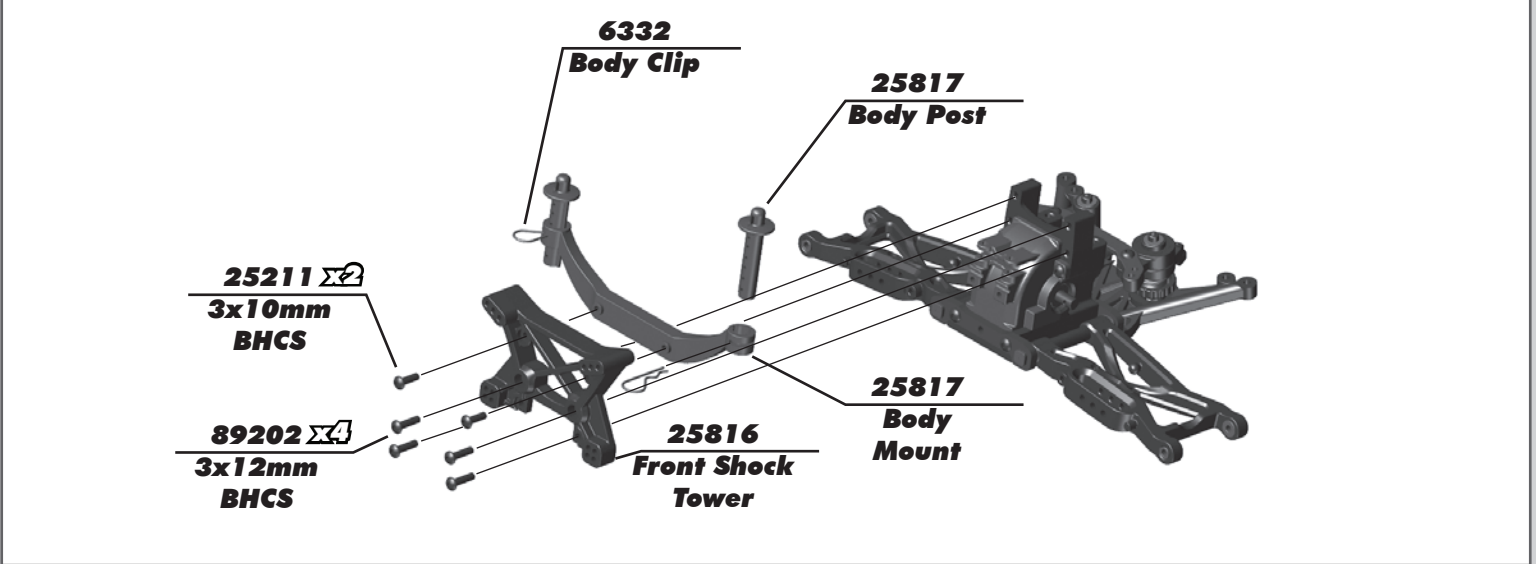

:: Step 12

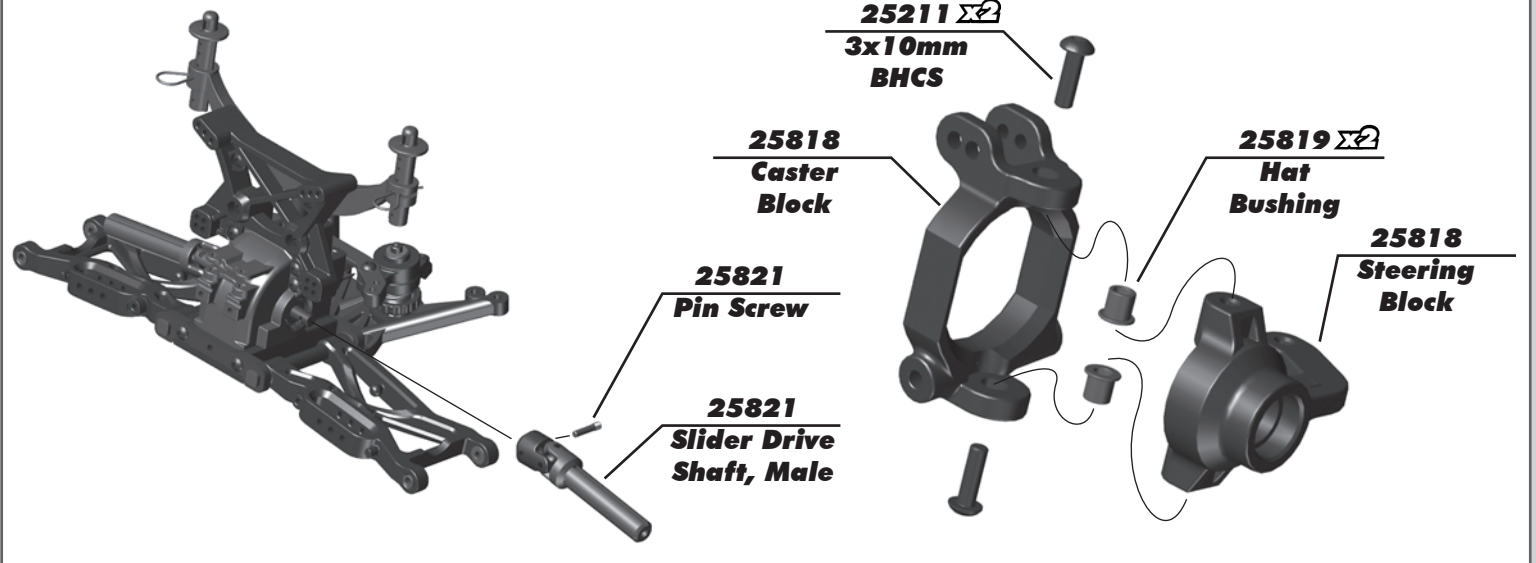

:: Step 13

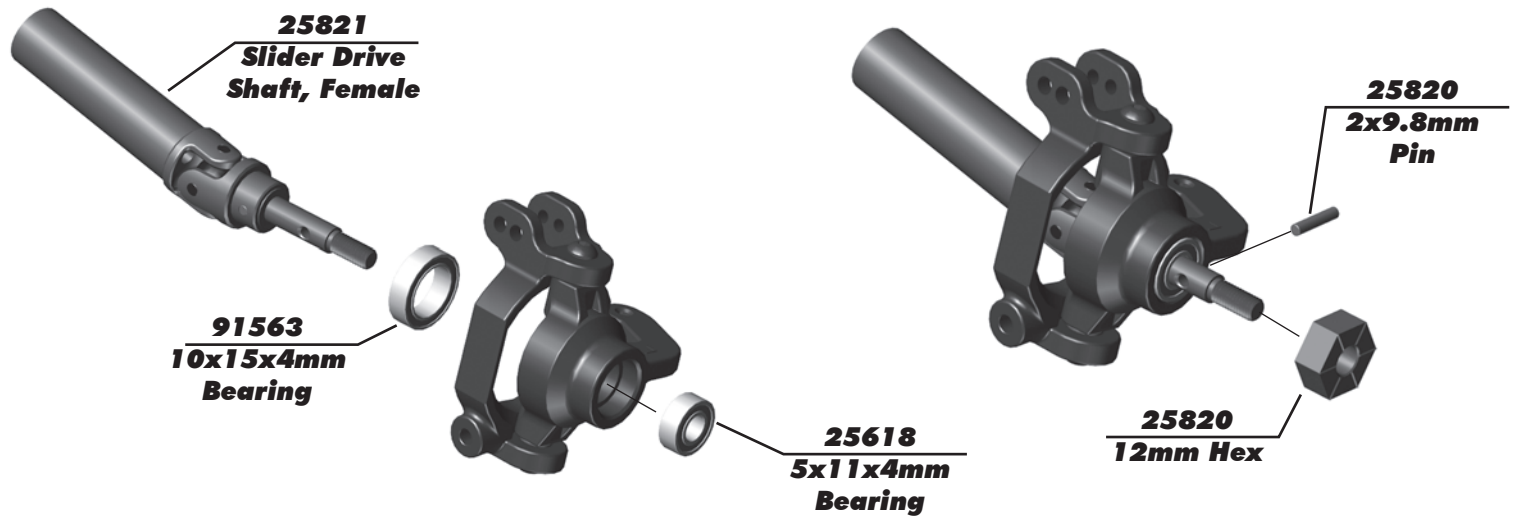

:: Step 14

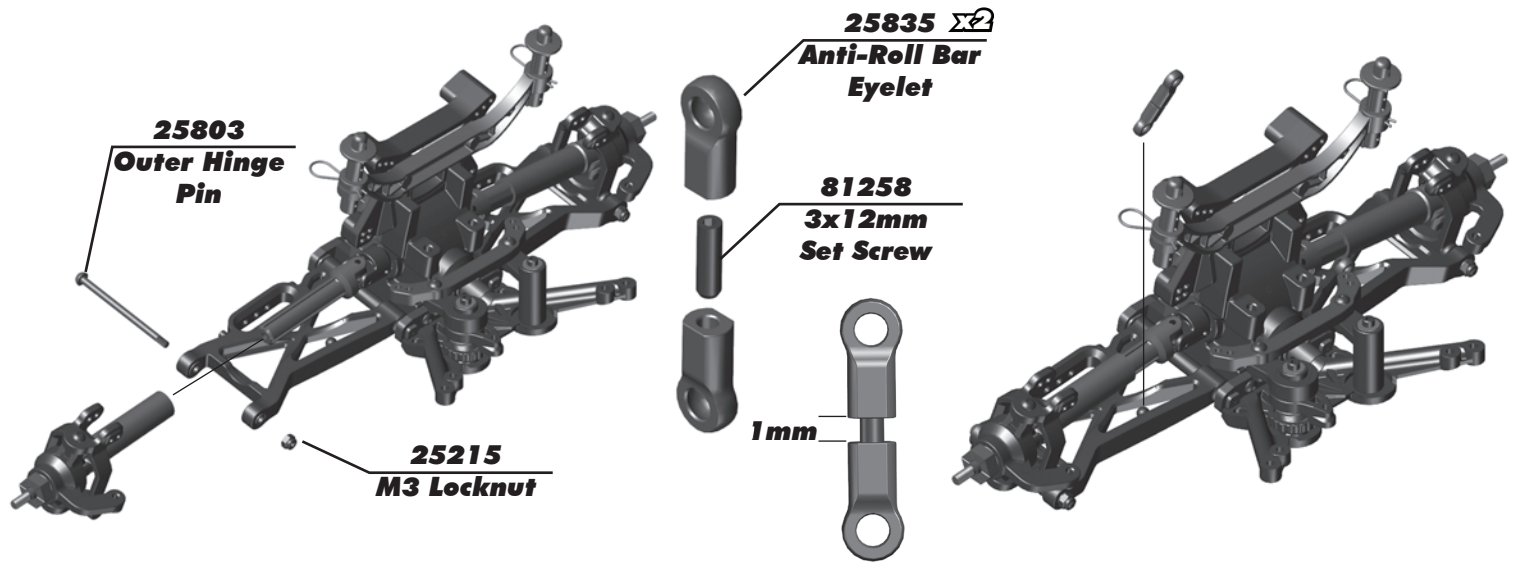

:: Step 15

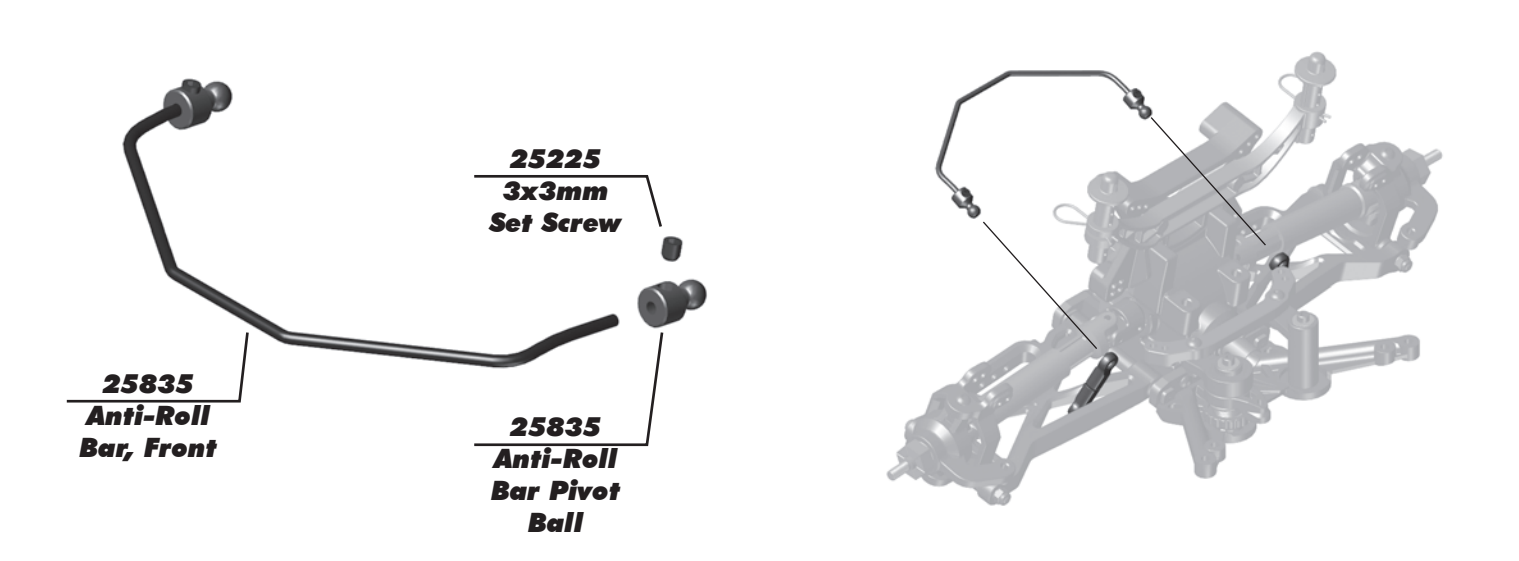

:: Step 16

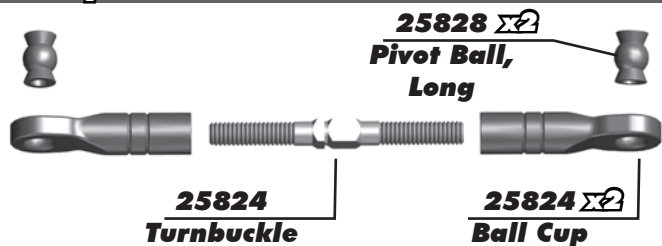

**Steering Turnbuckle
15.50mm**



Build x2 (right and left side)

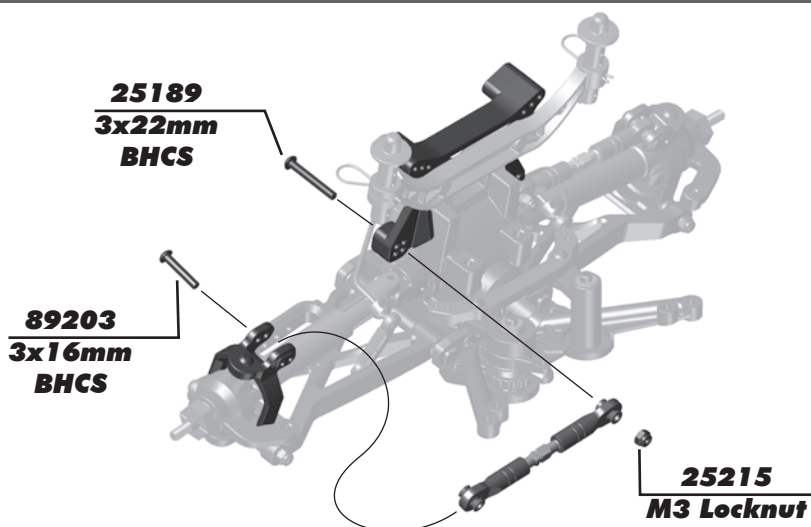

:: Step 17

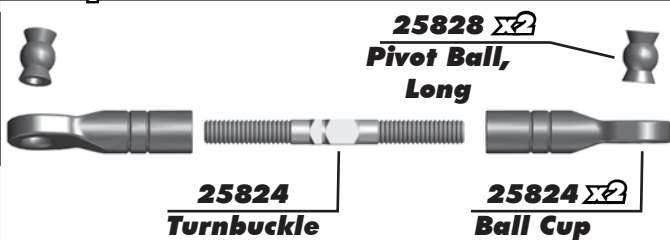

**Steering Turnbuckle
22.00mm**



Build x2 (right and left side)

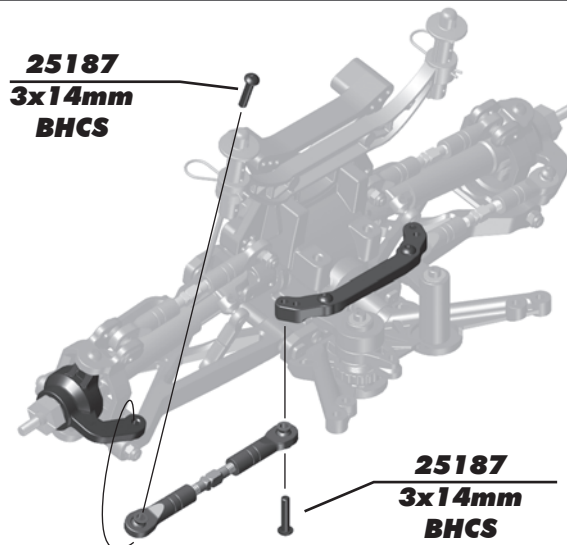

:: Step 18

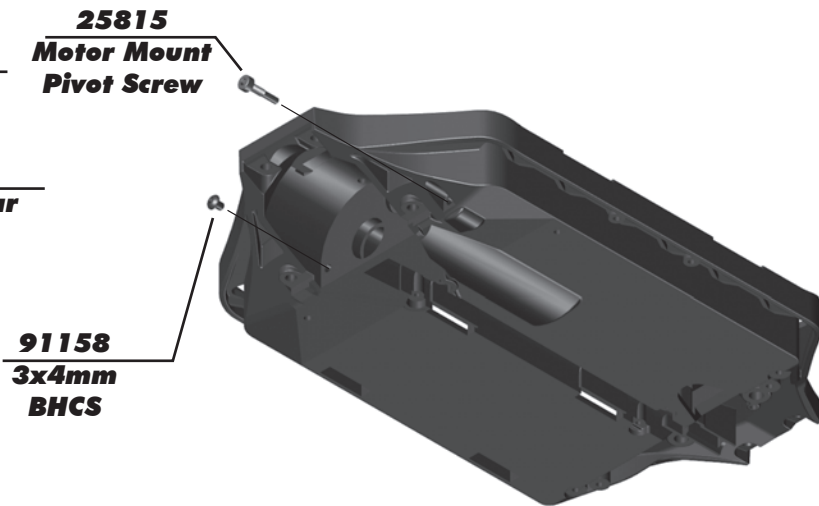
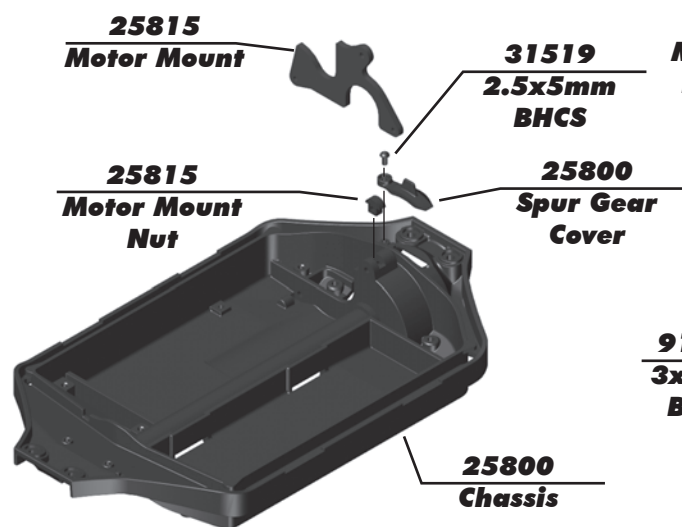

:: Step 19

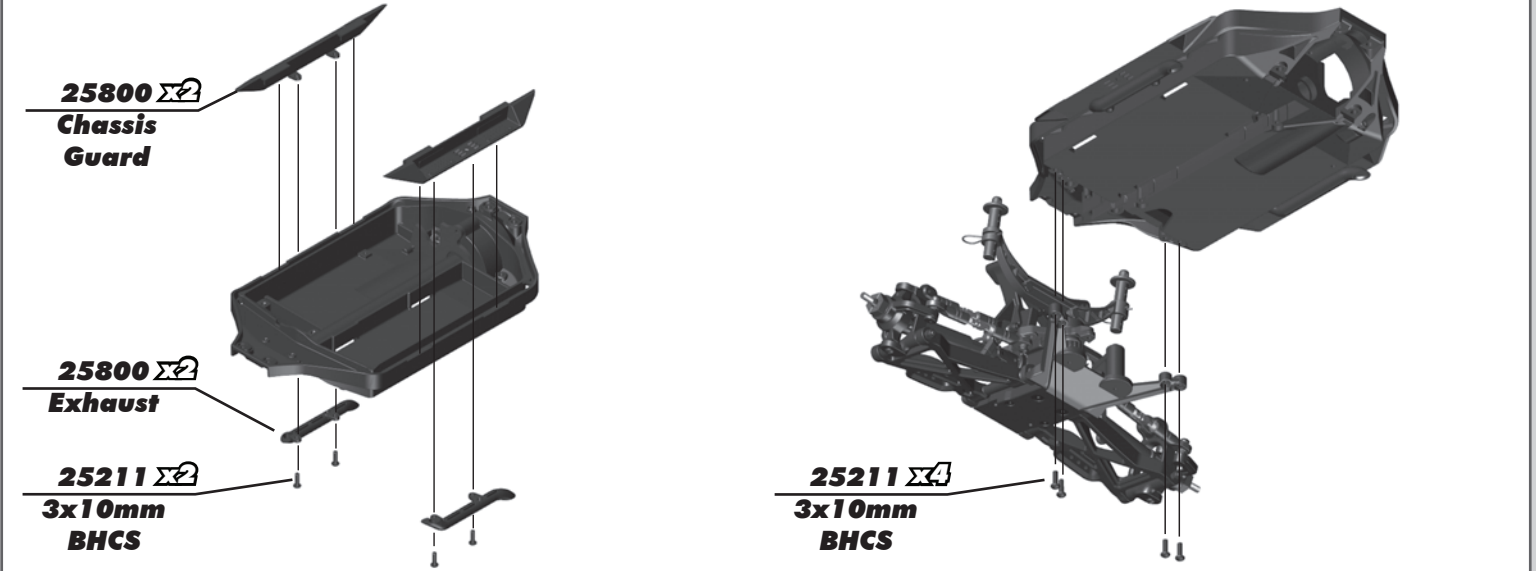

:: Step 20

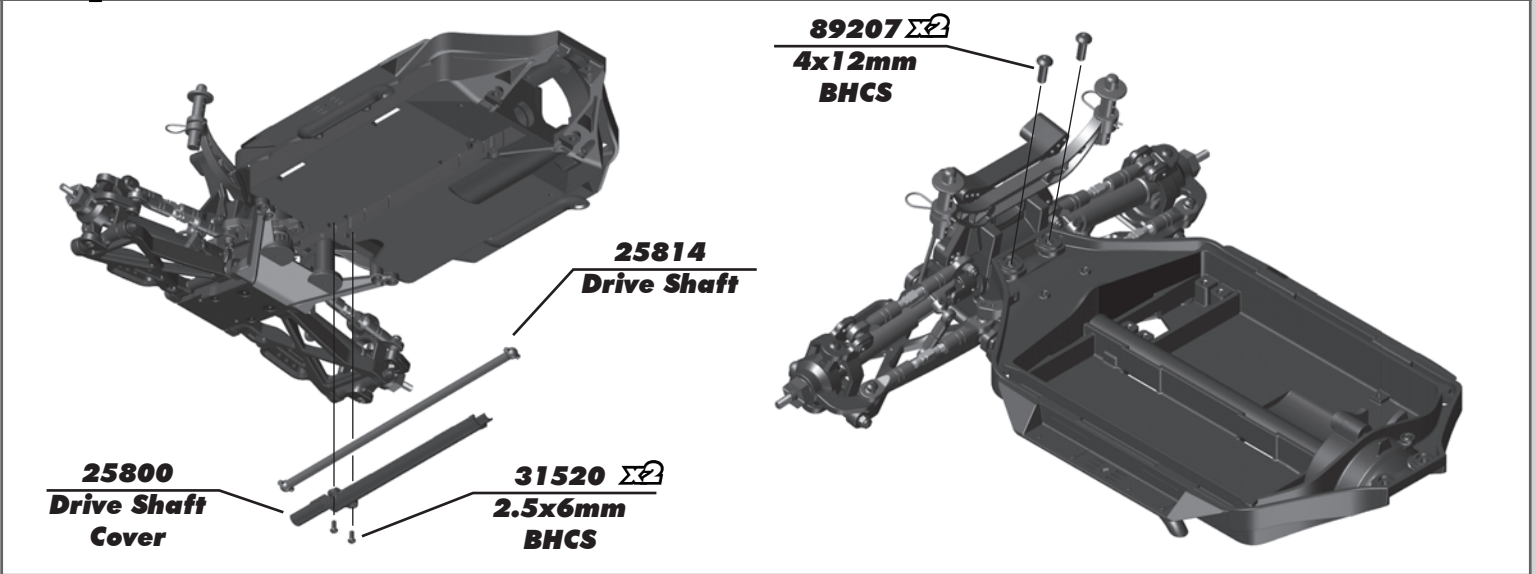

:: Step 21

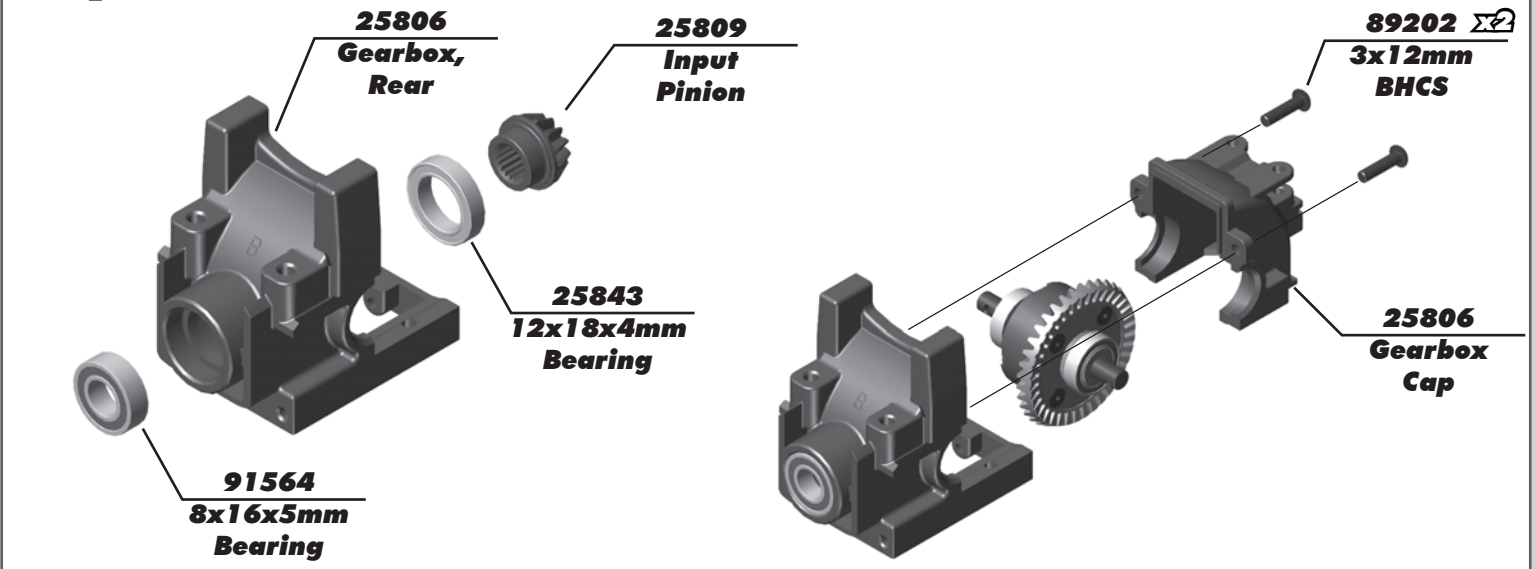

:: Step 22

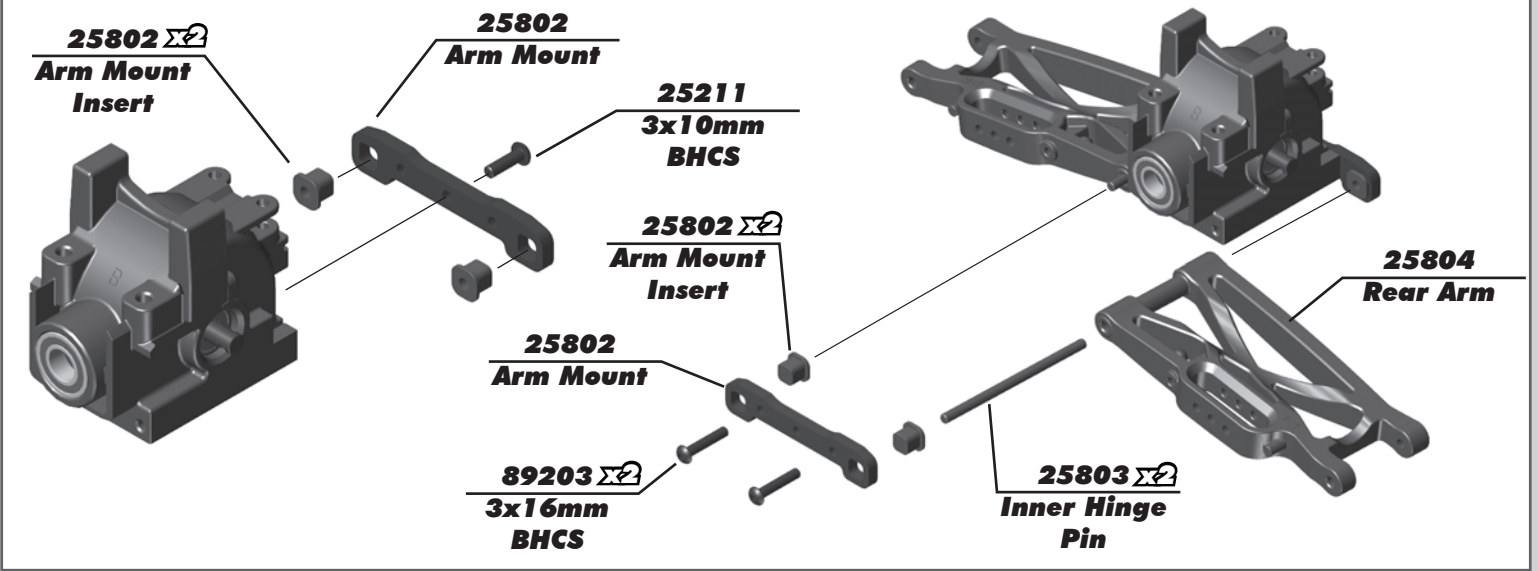

:: Step 23

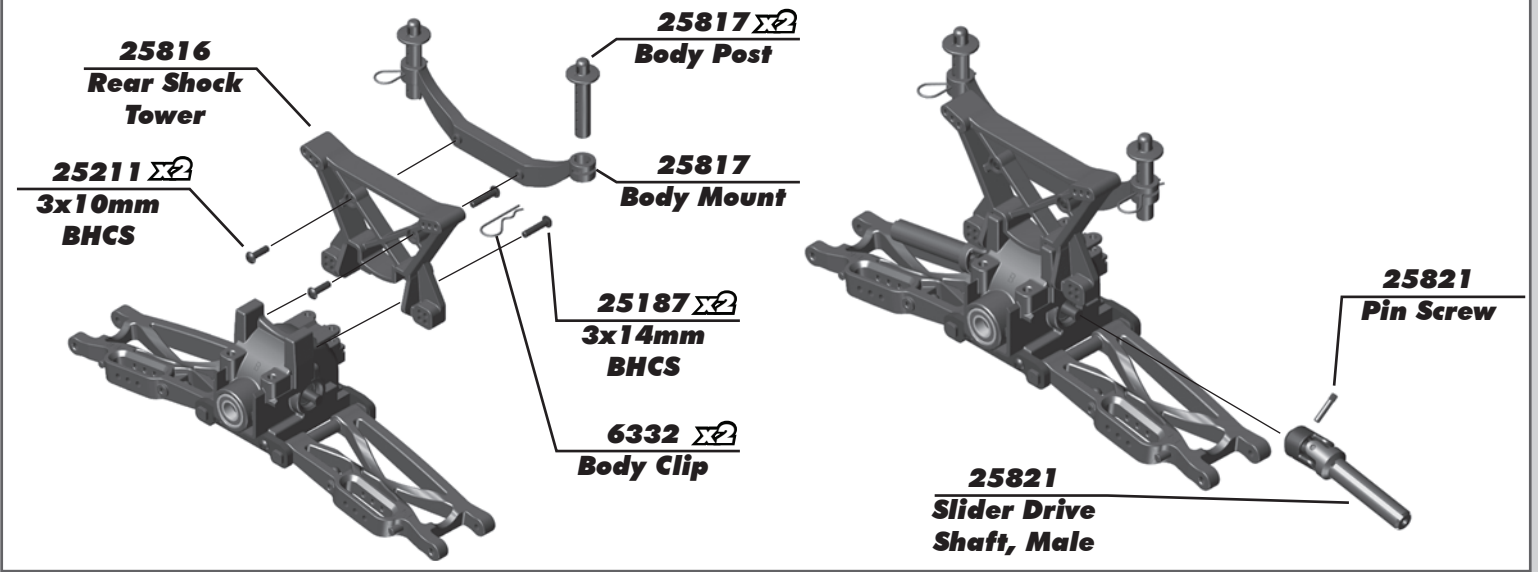

:: Step 24

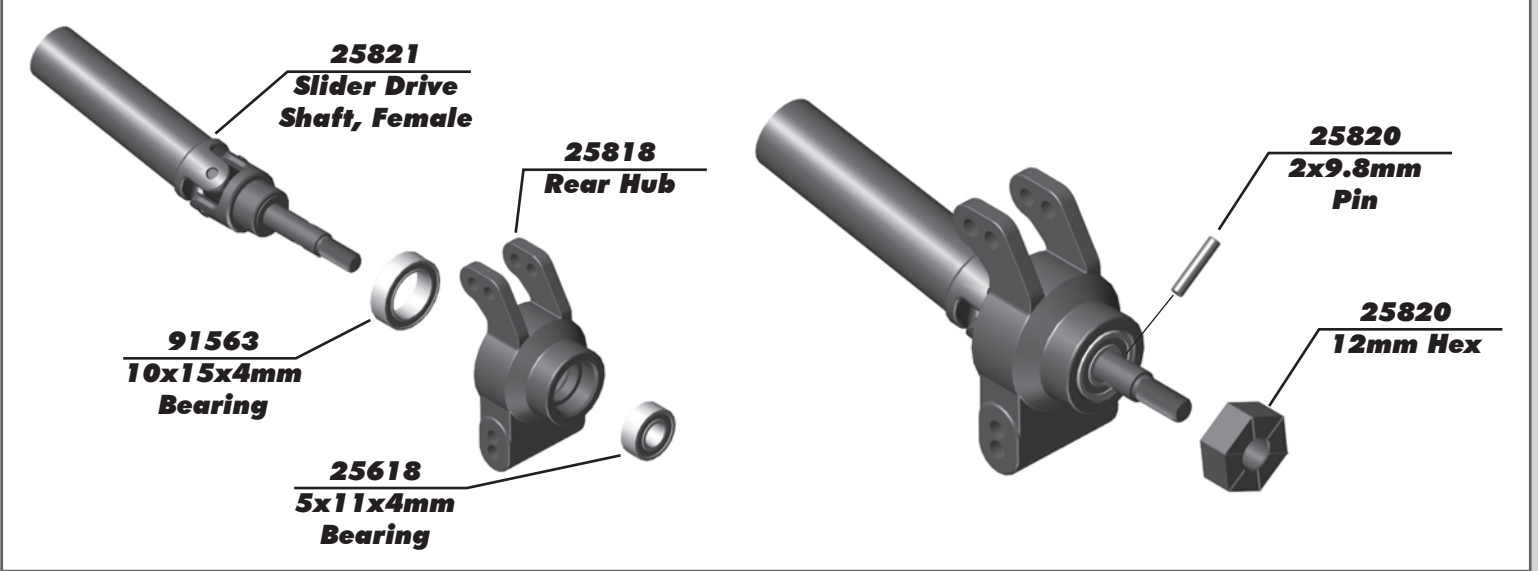

:: Step 25

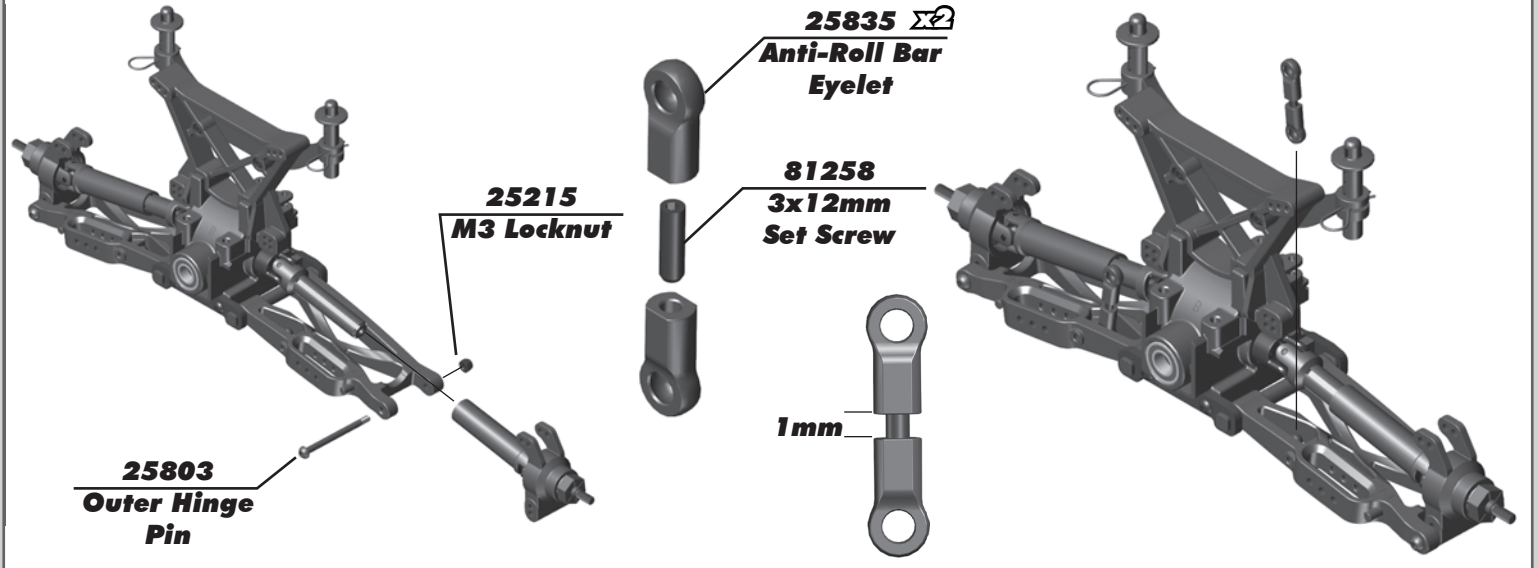

:: Step 26

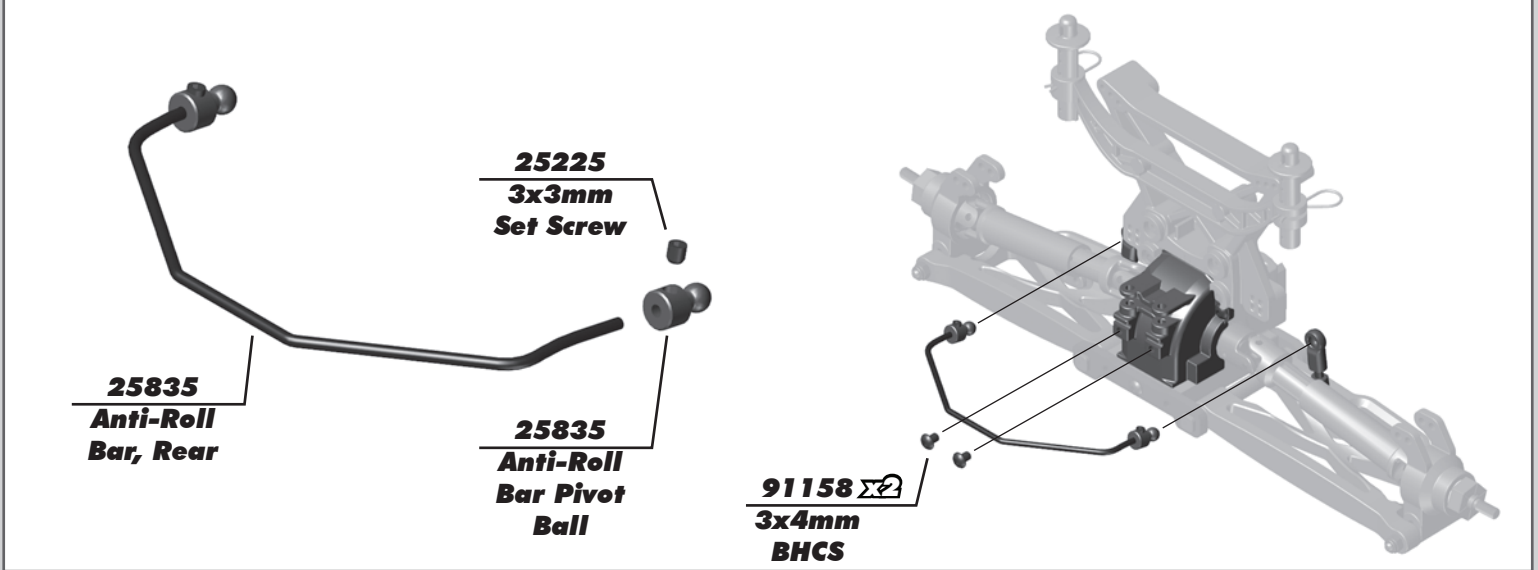

:: Step 27

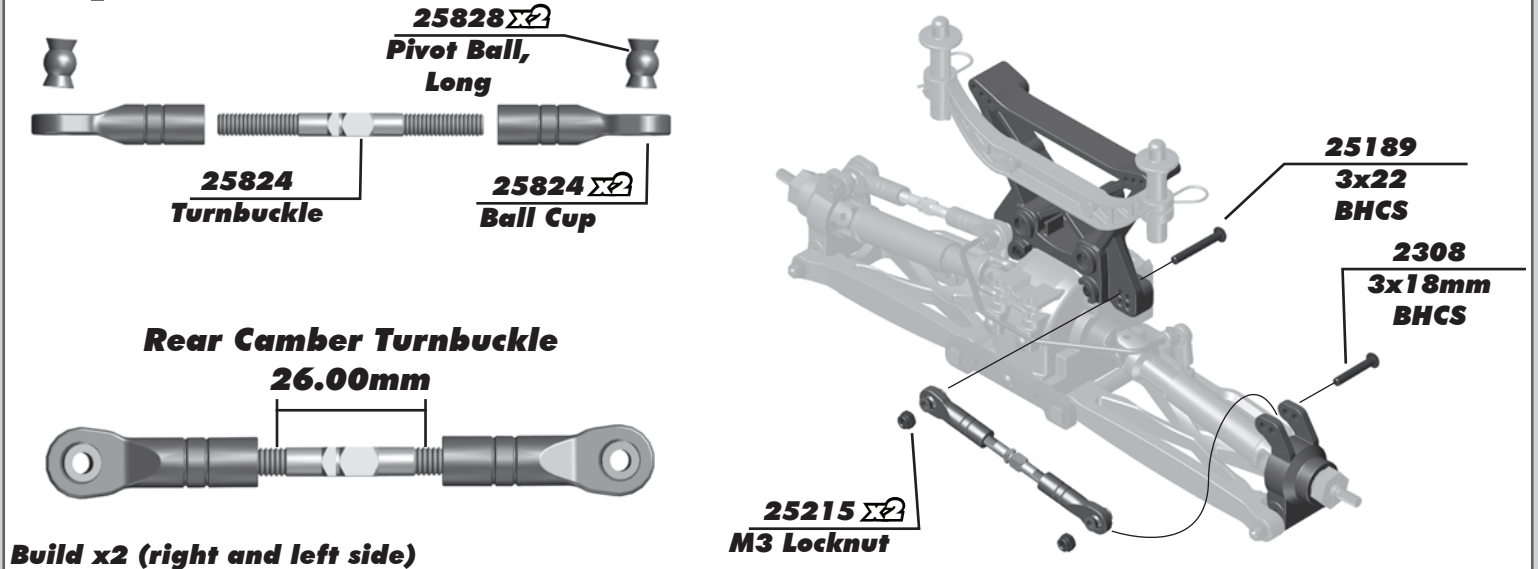

:: Step 28

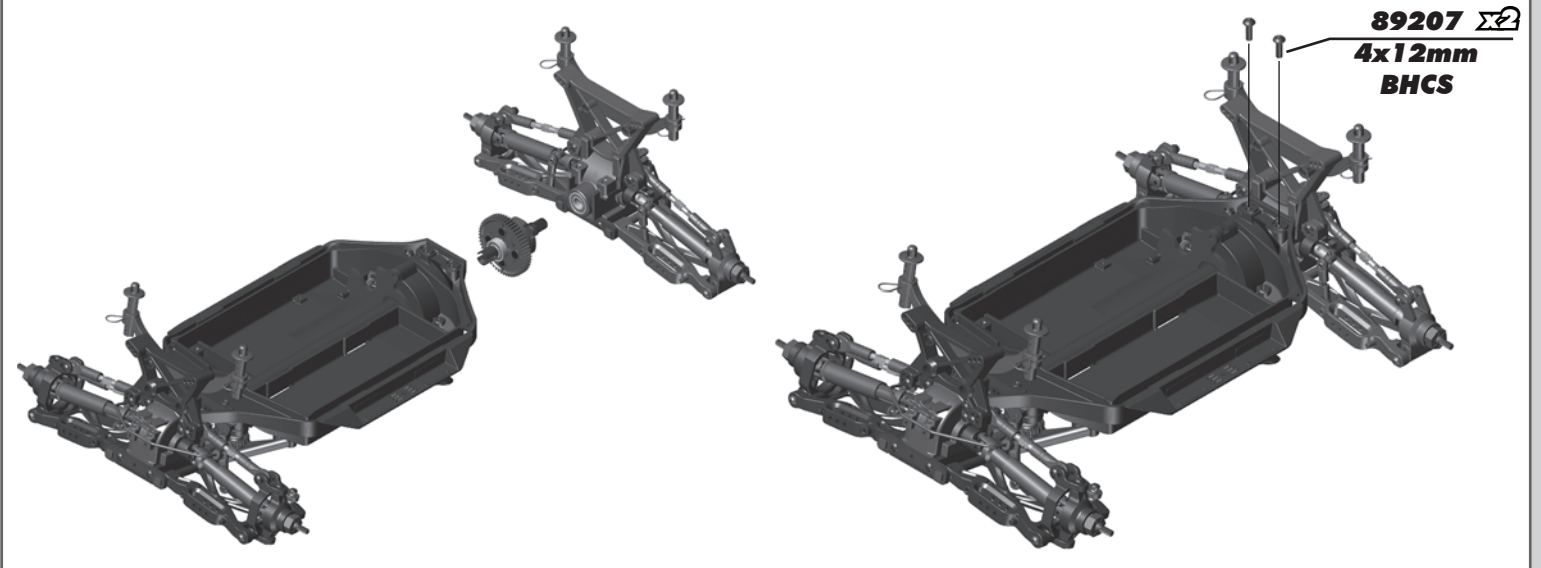

:: Step 29

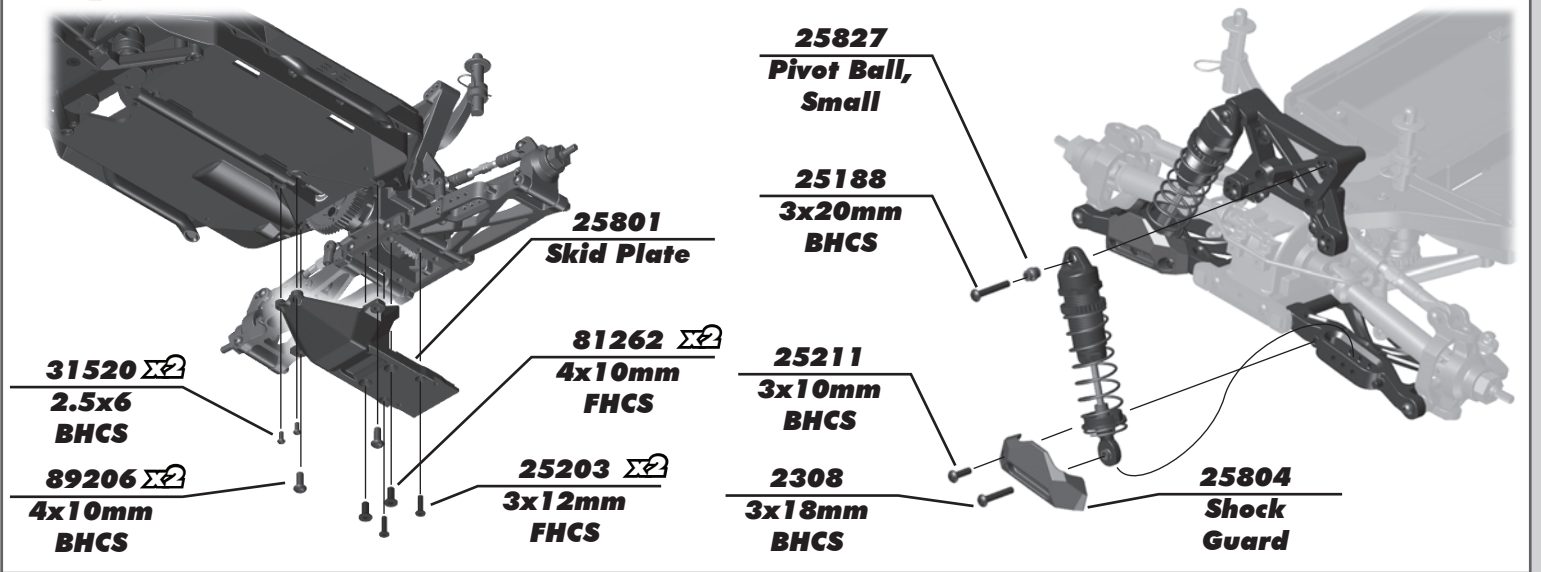

:: Step 30

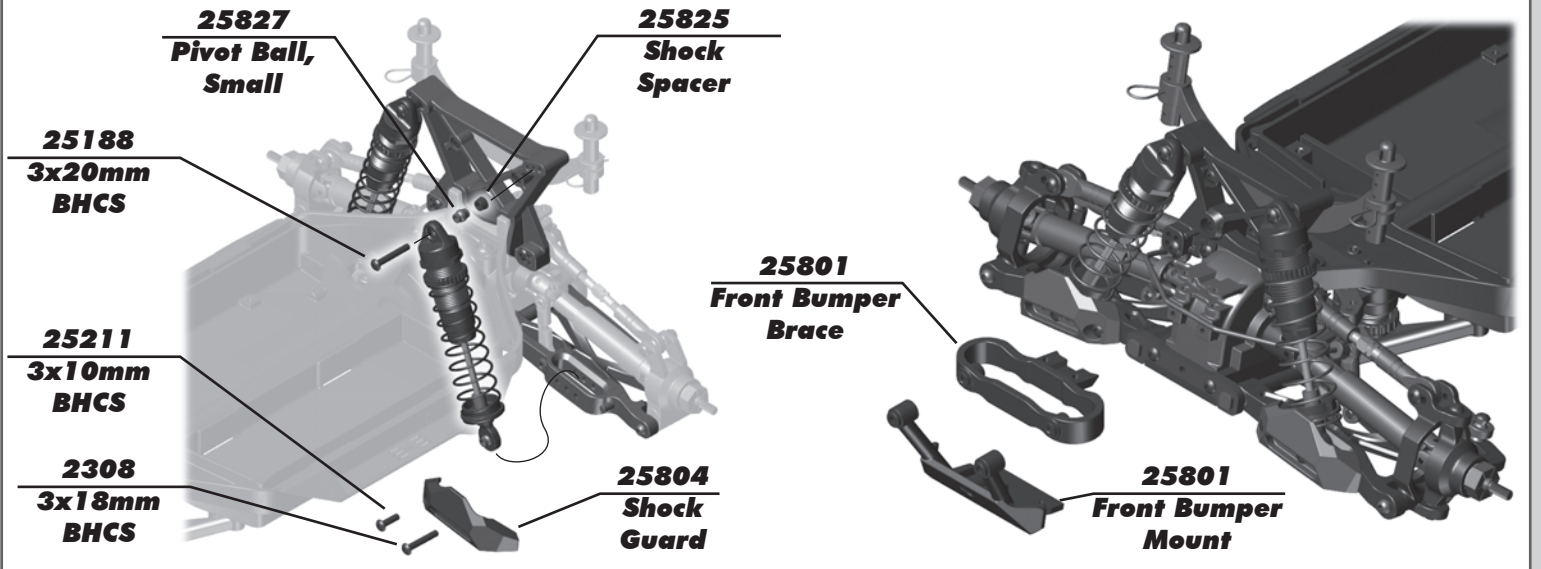

:: Step 31

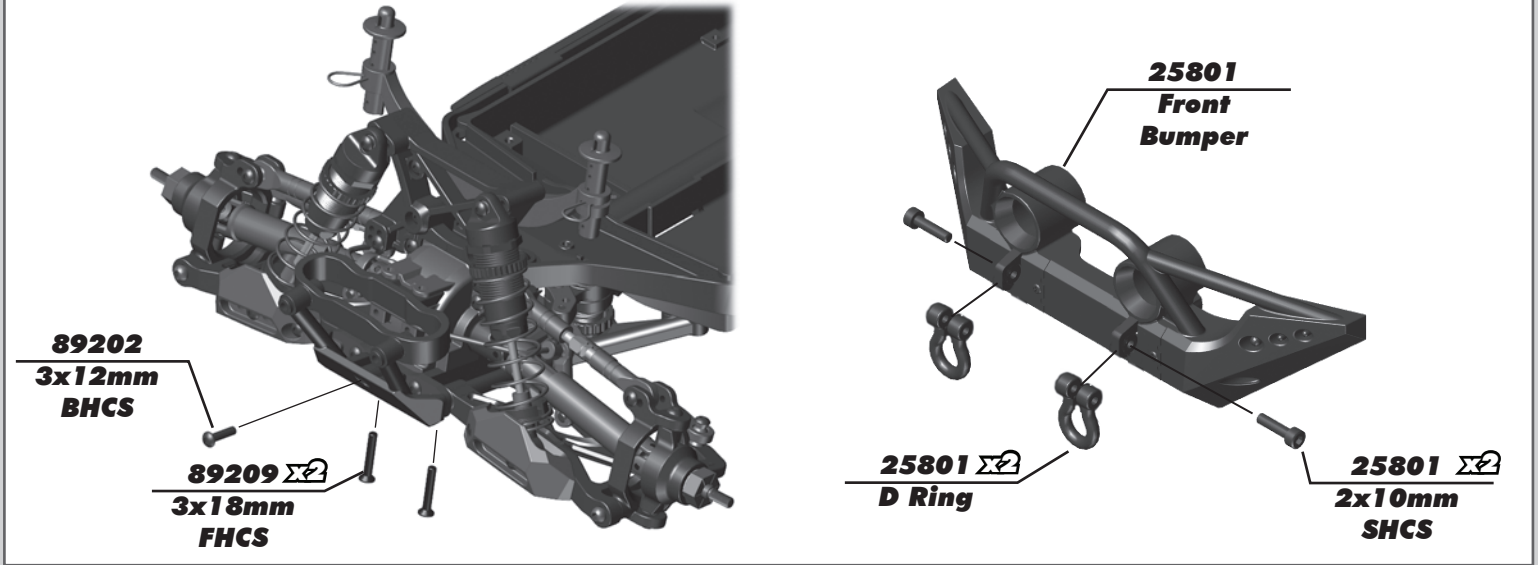

:: Step 32

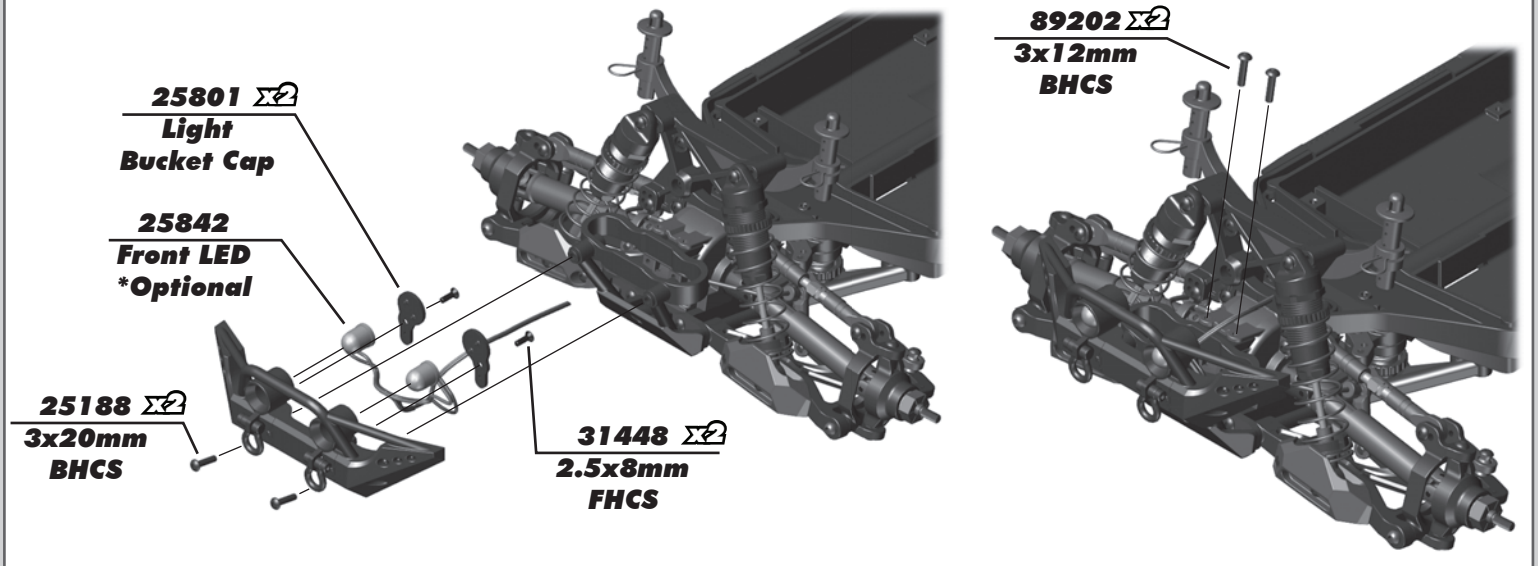

:: Step 33

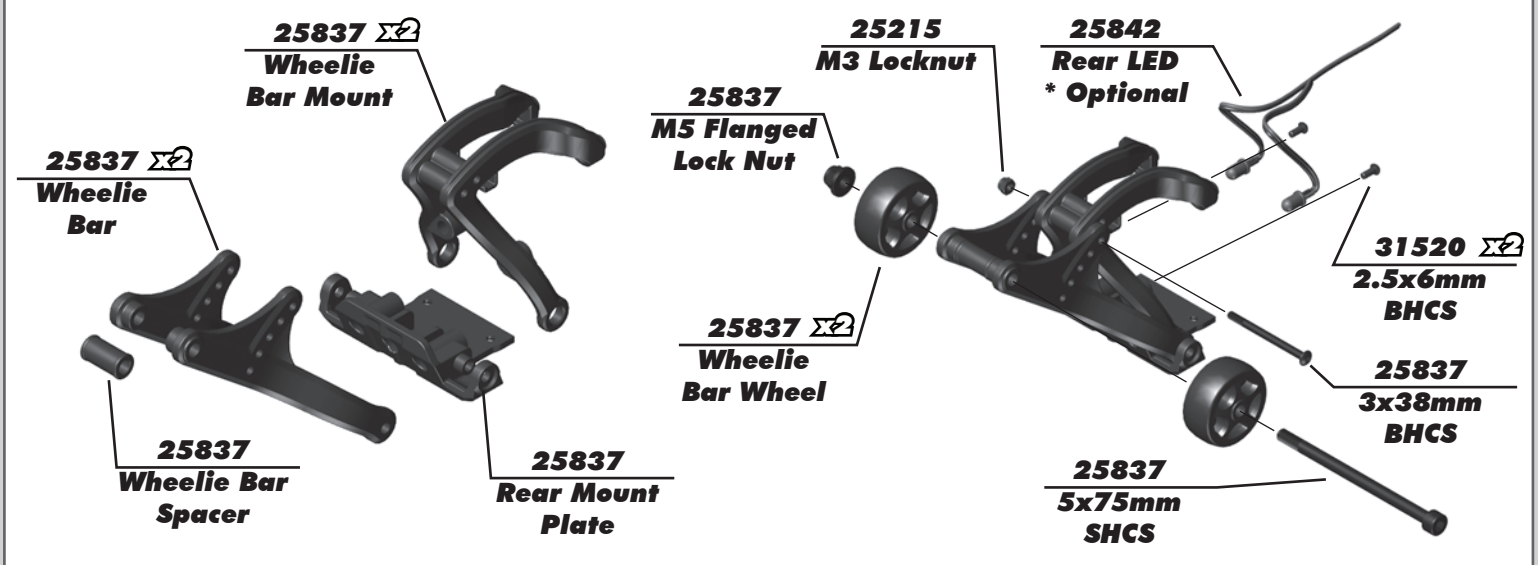

:: Step 34

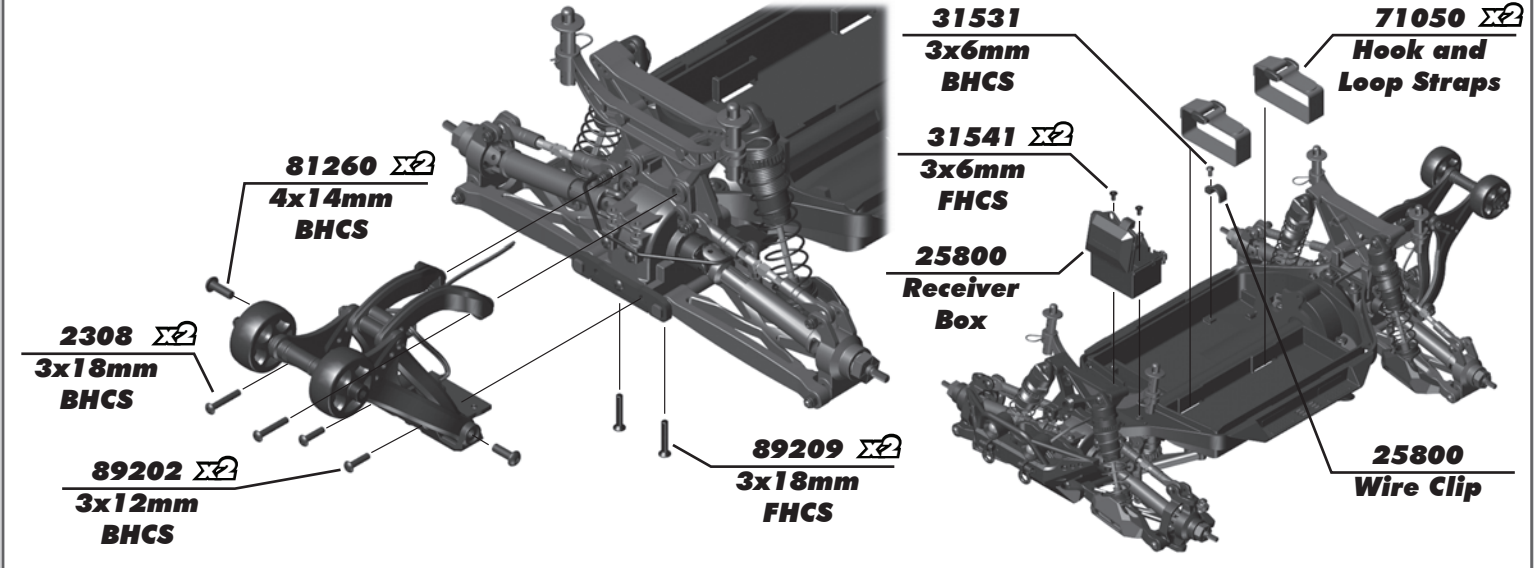

:: Step 35

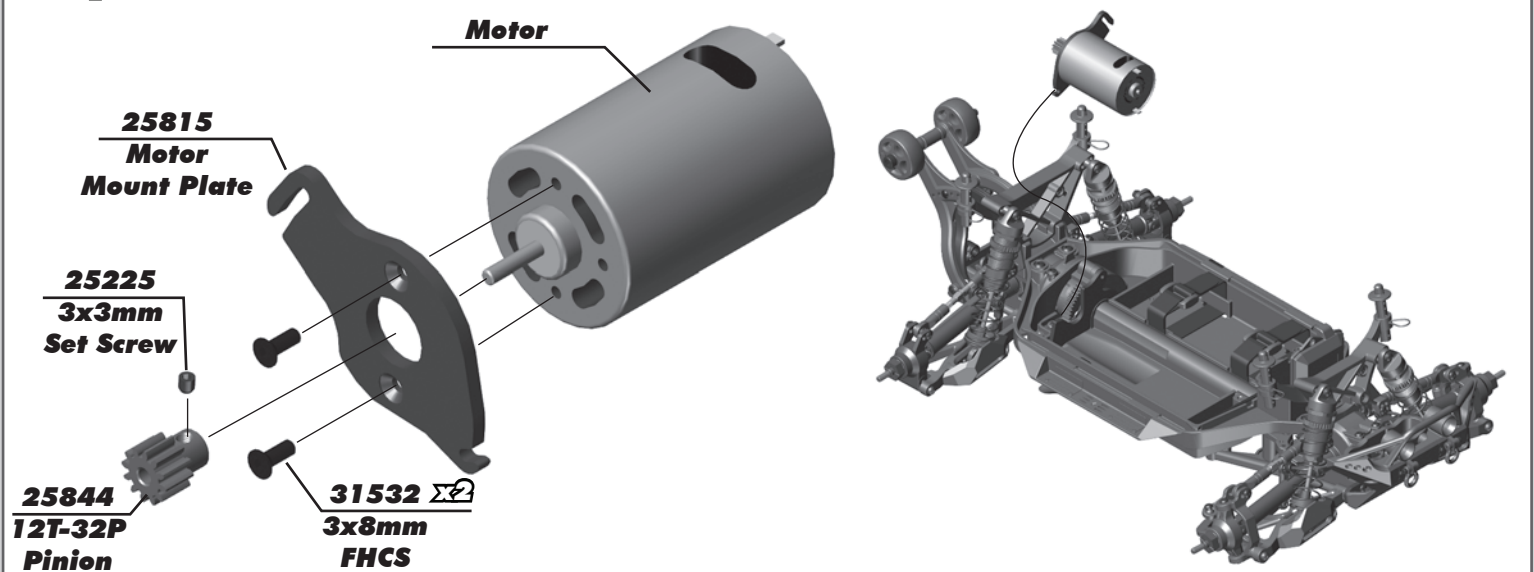

:: Step 36

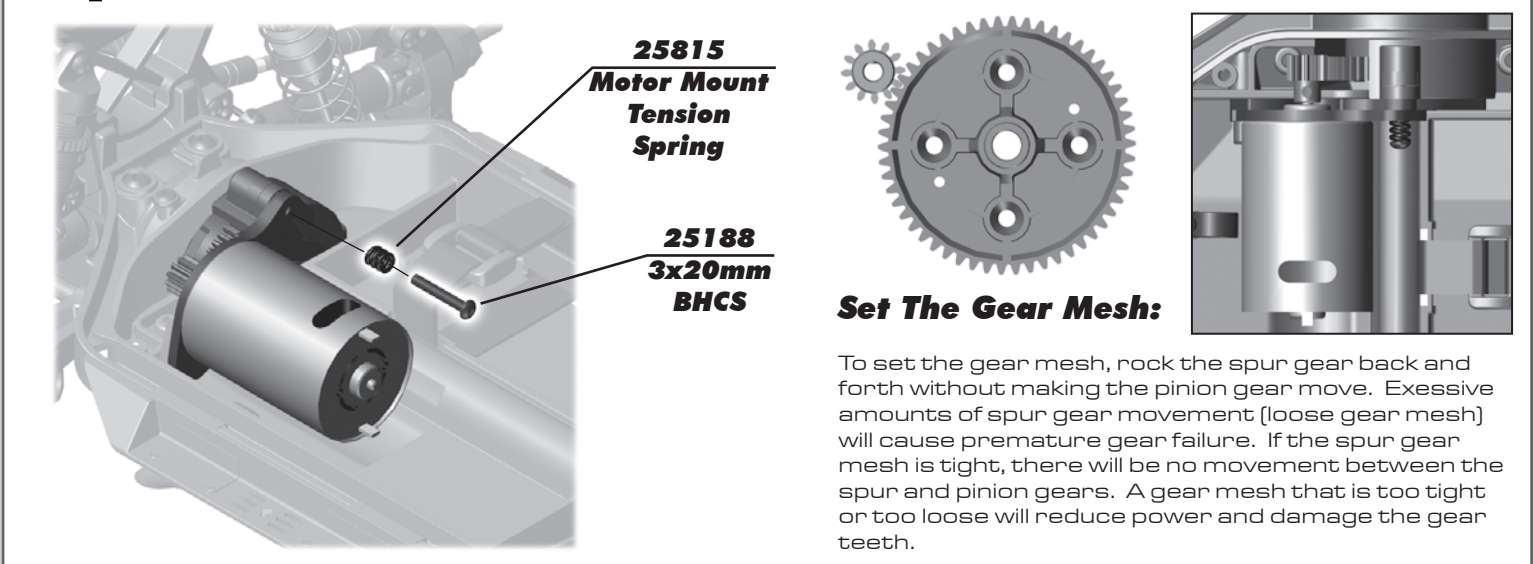

:: Step 37

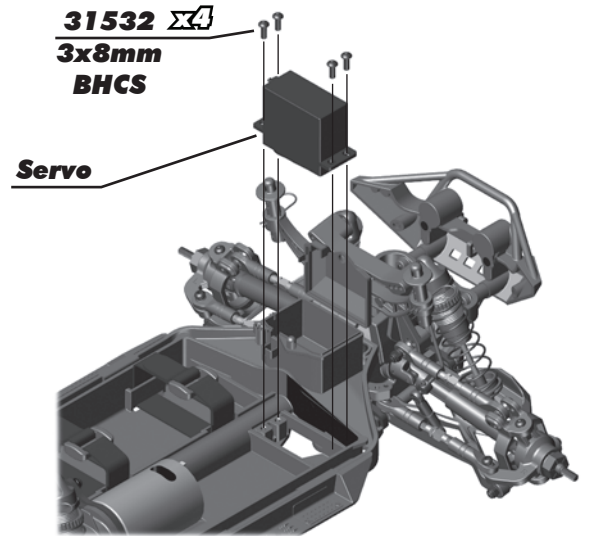
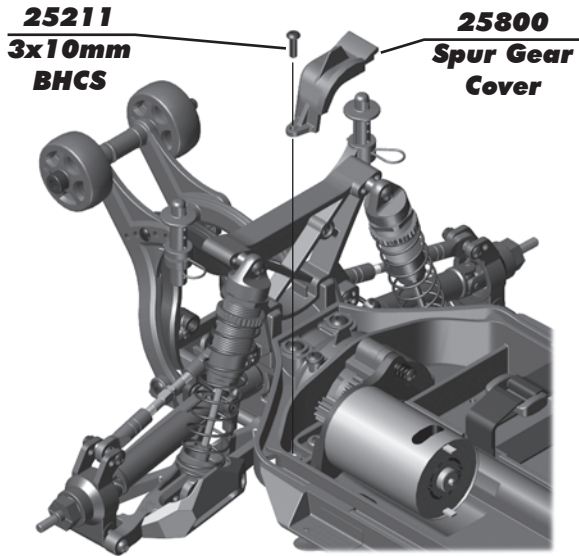

:: Step 38

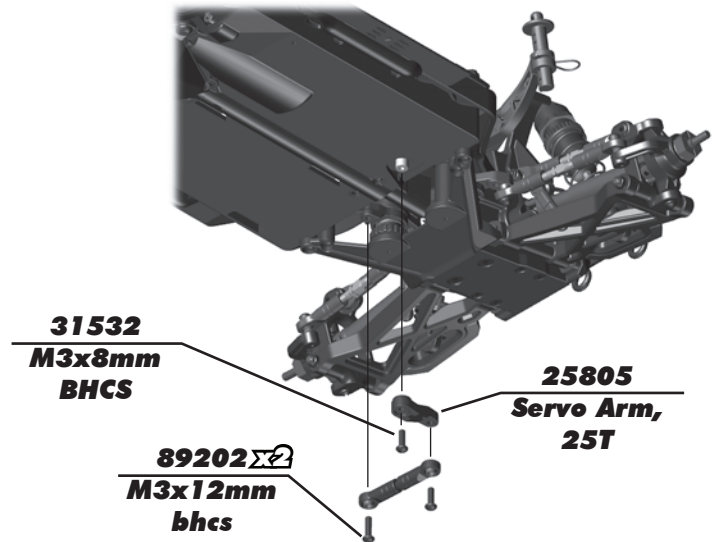
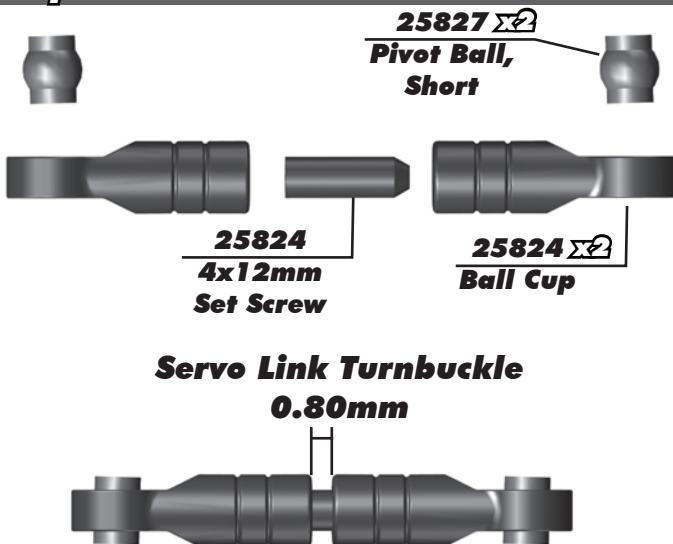

:: Step 39

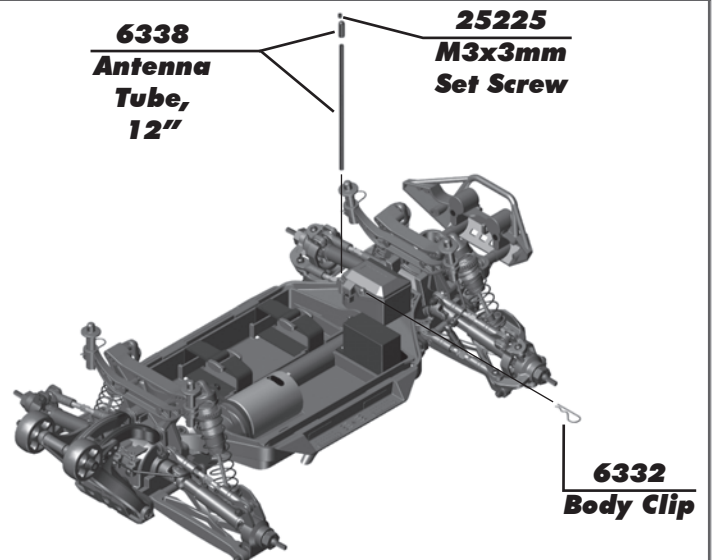
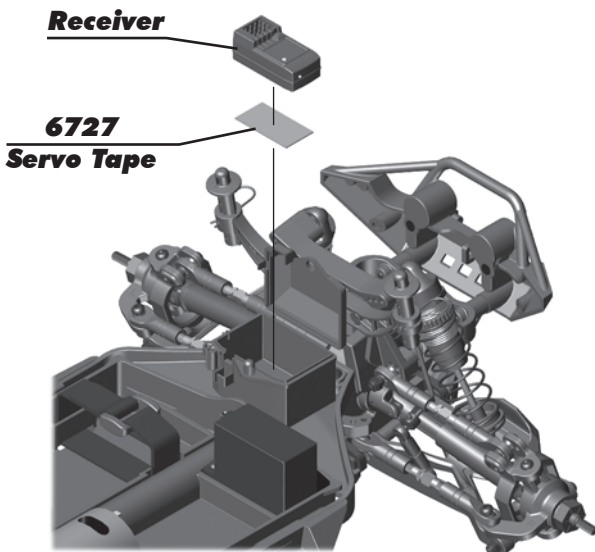

:: Step 40

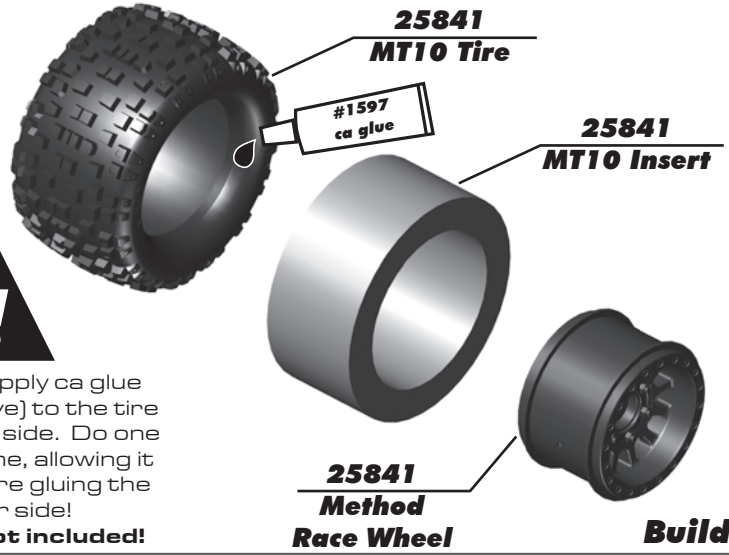
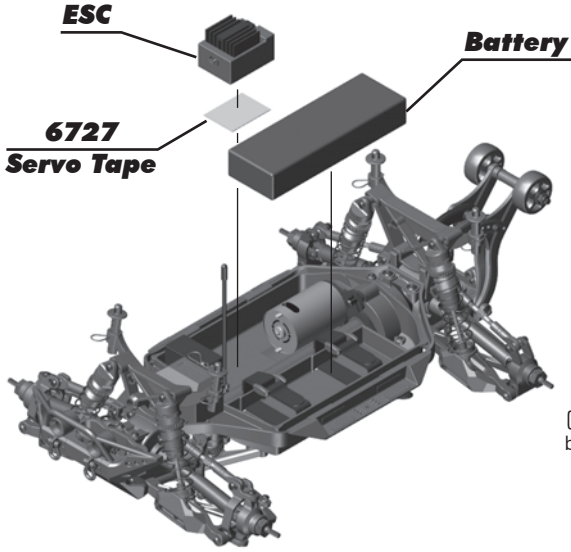

Carefully apply ca glue (tire adhesive) to the tire bead on the side. Do one side at a time, allowing it to dry before gluing the other side!
CA glue not included!

Build 4

:: Step 41

Install 4

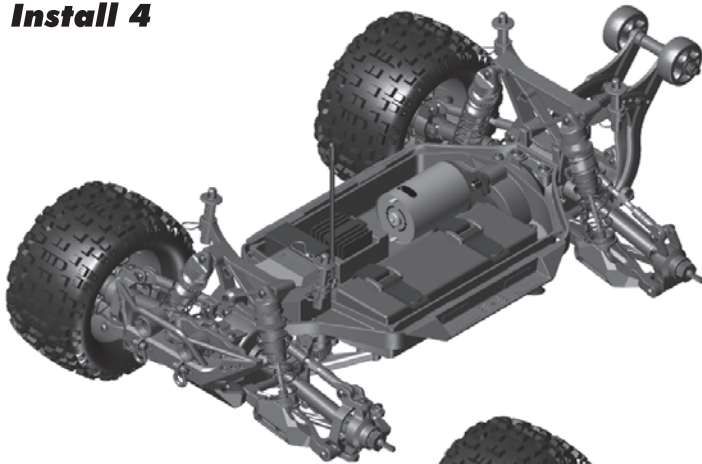

6332 x4 Body Clip

91738 x2 M4 Black Nut Serrated Aluminum

25841 x2 Method Race Wheel Cap

25840 Rival MT10 Body, Painted (Orange/Blue)

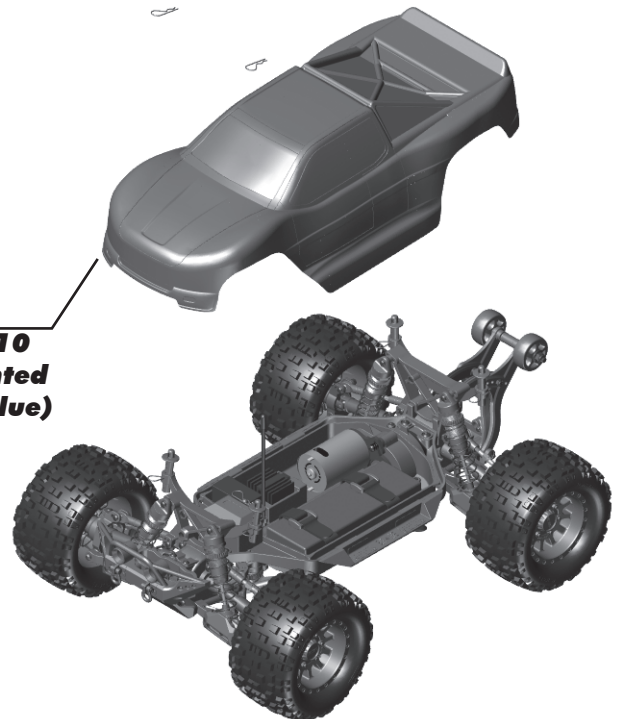

:: Tuning Tips**Tips for Beginners:**

Before making any changes to the standard setup, make sure you can get around the track without crashing. Changes to your vehicle will not be beneficial if you can't stay on the track. Your goal is consistent laps. Once you can get around the track consistently, start tuning your vehicle. Make only ONE adjustment at a time, testing it before making another change. If the result of your adjustment is a faster lap, mark the change on the included setup sheet (make additional copies of the sheet before writing on it). If your adjustment results in a slower lap, revert back to the previous setup and try another change. When you are satisfied with your vehicle, fill in the setup sheet thoroughly and file it away. Use this as a guide for future track days or conditions. Periodically check all moving suspension parts. Suspension components must be kept clean and move freely without binding to prevent poor and/or inconsistent handling.

Set The Gear Mesh:

You should be able to rock the spur gear back and forth in the teeth of the pinion gear without making the pinion gear move. If the spur gear mesh is tight, then loosen the #25188 screw and move the motor away, then try again. A gear mesh that is too tight or too loose will reduce power and damage the gear teeth.

Front Camber:

Camber describes the angle at which the tire and wheel rides when looked at from the front. Negative camber means that the tire leans inward at the top. A good starting camber setting is -1° . Positive camber, where the top of the tire is leaning out, is not recommended. Optional #1719 camber gauge can be used to more accurately set camber.

Rear Camber:

Camber describes the angle at which the tire and wheel rides when looked at from the back. Negative camber means that the tire leans inward at the top. A good starting camber setting is -1° . Adding a small amount of positive camber, where the top of the tire is leaning out, will tend to improve straight-line acceleration on loose tracks. Optional #1719 camber gauge can be used to more accurately set camber.

Front Camber Links:

Changing the length of the camber link is considered a bigger step than adjusting the ball end height on the tower. Shortening the camber link (or lowering the ball end) will give the front end less roll and quicken steering response. Lengthening the camber link (or raising the ball end) will give the front more roll and slower steering response. Longer camber links are typically used on high grip tracks and shorter links tend to work better on medium-grip loose tracks.

Rear Camber Link:

Changing the length of the camber link is considered a bigger step than adjusting the ball end height on the rear chassis brace. Shortening the camber link (or lowering the ball end) will give the rear end less roll and the car will tend to accelerate or "square up" better. Lengthening the camber link (or raising the ball end) will give the rear more roll and more cornering grip. Longer camber links are typically used on high grip tracks, while shorter links tend to work better on medium grip loose tracks. The kit setting is the best compromise of cornering grip and acceleration.

Ackermann:

Ackermann is the angle difference between the front wheels when they are turned to steer the car. For minimal tire slip, it is standard for the inside wheel to steer to a greater angle than the outside wheel. If corner entry steering is too aggressive, try increasing the Ackermann by moving the ball studs to the rearward holes. Increasing the Ackermann will increase the angle difference of the front wheels when steered, resulting in a more stable car on corner entry.

:: Optional Gear

25842	Rival MT10 LED Light Kit	1
25845	MT10 FT Shock Kit, front, aluminum	1
25846	MT10 FT Shock Kit, rear, aluminum	1
25847	MT10 FT Steel CVA Kit, front	1
25848	MT10 FT Steel CVA Kit, rear	1

:: Lubes & Adhesives / Misc.

1105	FT Green Slime Shock Lube	1
1596	FT Locking Adhesive	1
1597	FT Tire Adhesive, medium	1
6588	Black Grease - 4cc	1
6591	S.Diff Lube - 4cc	1
6636	Silicone Grease - 4cc	1
6727	Servo Tape	2

:: Shock Fluid

5420	10 Weight Silicone Shock Fluid	2oz.
5427	15 Weight Silicone Shock Fluid	2oz.
5421	20 Weight Silicone Shock Fluid	2oz.
5424	22.5 Weight Silicone Shock Fluid	2oz.
5428	25 Weight Silicone Shock Fluid	2oz.
5426	27.5 Weight Silicone Shock Fluid	2oz.
5422	30 Weight Silicone Shock Fluid	2oz.
5432	32.5 Weight Silicone Shock Fluid	2oz.
5429	35 Weight Silicone Shock Fluid	2oz.
5433	37.5 Weight Silicone Shock Fluid	2oz.
5423	40 Weight Silicone Shock Fluid	2oz.
5434	42.5 Weight Silicone Shock Fluid	2oz.
5430	45 Weight Silicone Shock Fluid	2oz.
5438	47.5 Weight Silicone Shock Fluid	2oz.
5435	50 Weight Silicone Shock Fluid	2oz.
5431	55 Weight Silicone Shock Fluid	2oz.
5436	60 Weight Silicone Shock Fluid	2oz.
5437	70 Weight Silicone Shock Fluid	2oz.
5425	80 Weight Silicone Shock Fluid	2oz.



:: Diff Fluid

5450	Silicone Diff Fluid 1,000CST	1
5451	Silicone Diff Fluid 2,000CST	1
5452	Silicone Diff Fluid 3,000CST	1
5444	Silicone Diff Fluid 4,000CST	1
5453	Silicone Diff Fluid 5,000CST	1
5446	Silicone Diff Fluid 6,000CST	1
5454	Silicone Diff Fluid 7,000CST	1
5455	Silicone Diff Fluid 10,000CST	1
5466	Silicone Diff Fluid 15,000CST	1
5456	Silicone Diff Fluid 20,000CST	1
5457	Silicone Diff Fluid 30,000CST	1
5458	Silicone Diff Fluid 60,000CST	1
5448	Silicone Diff Fluid 80,000CST	1
5459	Silicone Diff Fluid 100,000CST	1
5461	Silicone Diff Fluid 200,000CST	1
5463	Silicone Diff Fluid 500,000CST	1
5465	Silicone Diff Fluid 1,000,000CST	1



:: Optional Electronics Gear

For high performance electronics, visit www.reedypower.com or www.associatedelectrics.com/reedy/

Motors / Speed Controls / Batteries / Chargers / Servos / Accessories

