

# PRO2 SHORT WHEELBASE PRO10SW

# PRO2 SHORT WHEELBASE PRO10SW

# PRO2 SHORT WHEELBASE PRO10SW

**BRUSHLESS  
POWERED  
READY-TO-RUN**

SCALE  
**1:10**  
VEHICLE

**RTR**  
READY TO RUN

2 WHEEL DRIVE

ELEC. POWERED

OFF ROAD

2.4GHZ

PRE-PAINTED

1:10 Scale Ready-To-Run 2WD Electric Vehicle Manual & Catalog



**CHAMPIONS** *by* DESIGN

**TEAM ASSOCIATED**



## :: Introduction

Thank you for purchasing this Team Associated product. This assembly manual contains instructions and tips for building and maintaining your new RTR. Please take a moment to read through this manual to help familiarize yourself with these steps. We are continually changing and improving our designs; therefore, actual parts may appear slightly different than in the illustrations. New parts will be noted on supplementary sheets.

## :: RTR Features

- 2.4GHz 2-channel radio with new DVC (Dynamic Vehicle Control) receiver featuring built-in adjustable gyro
- High-torque, metal-gear Reedy Servo with spring style servo saver
- Powerful Reedy 3300kV brushless motor
- Water-resistant high-power Reedy brushless speed control with T-plug connector and LiPo low voltage cutoff
- Water-resistant enclosed receiver box
- Lightweight street stock inspired wheels
- High grip all terrain tires
- Durable and lightweight aluminum top shaft
- Low center-of-gravity molded composite chassis with hook-and-loop battery straps that accommodate both NiMH and 2/3s LiPo battery packs
- Metric hardware throughout
- 22 precision rubber-sealed ball bearings
- Impact absorbing front and rear bumpers
- Adjustable body mounts
- Rear CVA drive shafts for more reliability
- Aluminum 12mm big bore coil-over shock absorbers
- 2.6:1 ratio gearbox with heavy-duty sealed gear differential and externally adjustable slipper clutch
- Rugged steel turnbuckles for adjustable camber and front toe-in
- Adjustable suspension geometry
- Vertical ball ends for roll center adjustments, front and rear
- Many Factory Team options already available!

## :: Additional

Your new RTR comes factory assembled including radio gear, motor, and ESC. However, there are some items you will need to complete your kit (refer to catalog section for suggestions):

- AA-size batteries for transmitter (x4)
- Peak Detection Charger or LiPo Compatible Charger
- 6 cell NiMH battery pack or 2S LiPo battery pack w/High Current T Plug.

Tools included:

- Allen wrenches 1.5mm, 2.0mm, 2.5mm
- 12mm Shock Tool
- Multi-wrench

## :: Other Helpful Items

- Green Slime shock lube (AE # 1105)
- Thread Locking Compound (AE # 1596)
- Silicone Diff Fluid (Refer to catalog for complete listings)
- 7 Piece Hex Driver Set (AE # 1650)
- FT Dual Turnbuckle Wrench (AE # 1114)
- Calipers or a Precision Ruler
- FT Nut Drivers (AE #1666 - 1668, used with #1650 handle)
- FT Tire Adhesive, medium (AE # 1597)
- Silicone Shock Fluid (Refer to catalog for complete listings)
- Body Scissors (AE # 1737)
- FT Hex Wrenches (AE # 1650)
- Needle Nose Pliers
- Reamer / Hole Punch
- Wire Cutters
- Soldering Iron
- Ride Height Gauge
- Hobby Knife













**Associated Electrics, Inc.**  
21062 Bake Parkway.  
Lake Forest, CA 92630



**Customer Service**  
Tel: 949.544.7500  
Fax: 949.544.7501

**:: Hardware - 1:1 Scale View**

**Button Head (bhcs)**

-  **2x4mm (31510)**
-  **2.5x8mm (31521)**
-  **3x5mm (31530)**
-  **3x8mm (31532)**
-  **3x10mm (25211)**
-  **3x12mm (89202)**
-  **3x14mm (25187)**
-  **3x16mm (89203)**
-  **3x22mm (25189)**
-  **3x24mm (89204)**
-  **3x26mm (89205)**
-  **3x30mm (91478)**





**Cap Head (shcs)**

-  **2.5 x 14mm (71032)**

**Clips**

-  **E-clip 1/8 (6299)**





**Flat Head (fhcs)**

-  **3x8mm (25201)**
-  **3x10mm (25202)**
-  **3x12mm (25203)**
-  **3x14mm (89208)**
-  **3x16mm (25204)**





**Set Screws**

-  **3x3mm (25225)**



**Shims and Washers**

-  **Servo Mount Washer (89218)**  
**(.250 x .125 x .815)**
-  **FT Ballstud Washer, Aluminum**  
**(0.5mm) (31381)**
-  **FT Ballstud Washer, Aluminum**  
**(1mm) (31382)**
-  **FT Ballstud Washer, Aluminum**  
**(2mm) (31383)**
-  **3x6x0.5mm Washer (89218)**

**Ball Bearings**

-  **3x7x3mm (91475)**
-  **5x10x4mm (91560)**
-  **6x13x5 (91562)**
-  **10x15x4 (91563)**

**Ballstuds**

-  **HD 6mm (91047)**
-  **HD 8mm (91048)**
-  **HD 10mm (91049)**

**Nuts (lock/plain)**

-  **M3 Nut (91477)**
-  **M3 Alum. Locknut, Blue (31550)**
-  **M3 Locknut, Black (25215)**
-  **M3 Locknut w/Flange (25612)**
-  **FT 3mm Locknuts, Blue(25392)**
-  **M4 Locknut w/Flange (91378)**
-  **FT M4 Locknuts w/Flange,**  
**Blue (31551)**

**Notes:**

**:: Table of Contents**

1..... Cover	13.....Gearbox Install
2..... Introduction	14.....Rear Hub and CVA Build
3.....1:1 Hardware “Fold Out”	14 - 15.....Turnbuckles Build
4..... Table of Contents	15 - 17.....Shocks Build
5 - 6.....Quick Start Guide	17 - 19.....Electronics Build
7.....Front Top Plate and Steering Build	19 - 20.....Bumpers and Chassis Braces Build
8 - 9.....Front Suspension Build	20 - 21.....Tires and Body Build
9 - 10.....Rear Suspension Build	21.....Tuning Tips
10 - 11.....Gear Differential Build	22.....Back Cover
11 - 12.....Gearbox Build	
12.....Slipper Build	

**:: Notes**

***This symbol indicates a special note or instruction in the manual.***



***This symbol indicates a Racers Tip.***



***There is a 1:1 hardware foldout page in the front of the manual. To check the size of a part, line up your hardware with the correct drawing until you find the exact size. Each part in the foldout has a number assigned to it for ordering replacement parts.***

**Associated Electrics, Inc.  
21062 Bake Parkway.  
Lake Forest, CA 92630**



**Customer Service  
Tel: 949.544.7500  
Fax: 949.544.7501**

## :: Quick Start Guide

### Battery Charging Steps and Safety:

Remove the battery from the vehicle before charging.  
Place battery on a fire resistant surface.  
Avoid any contact with water or other liquids.  
Be sure to select the correct charging mode for the type of battery you are charging.

**ALWAYS** use a compatible charger for charging your batteries.

**Caution: Never leave the battery unattended while charging. Always disconnect the charger from the power source when finished charging.**

**Caution: Always disconnect the battery when you are finished driving the vehicle.**



**Peak Detection  
Quick Charger**

## :: Quick Start Guide - (cont.)

### Battery Installation:

1. Install the battery with the battery wires directed towards the front of the vehicle.
2. Secure the hook and loop strap near the rear shock tower. Pull the strap over the motor wires for added security.
3. Secure the hook and loop strap near the front shock tower.

You may move the foam pad to either the front or the rear of the battery compartment to adjust the weight balance of the vehicle.

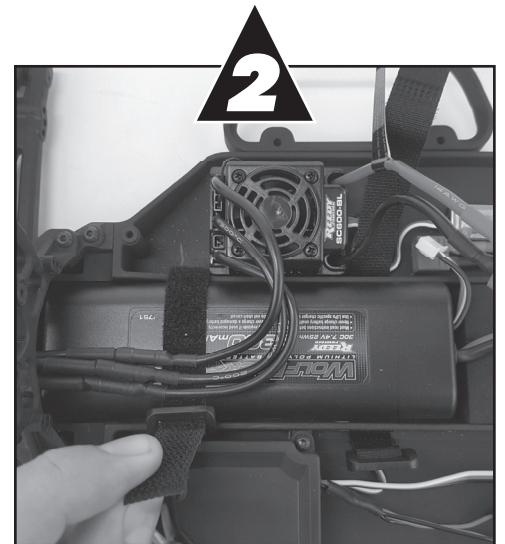
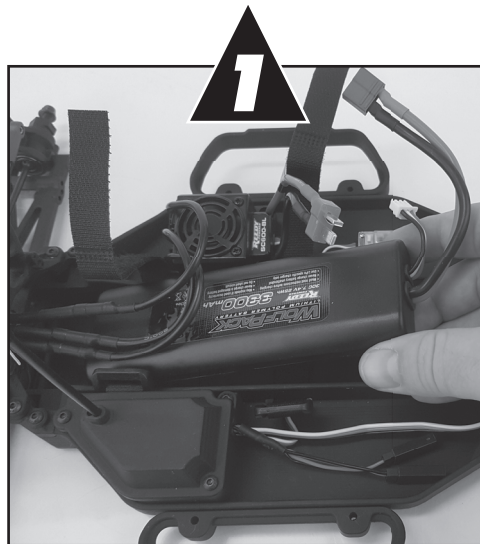

## :: Quick Start Guide - (cont.)

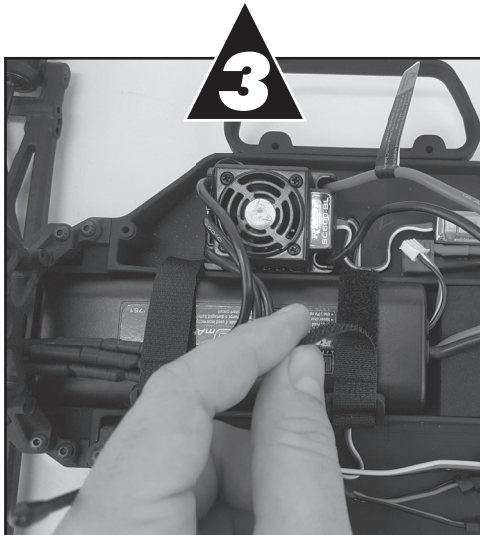

**Install antenna wire through antenna tube, then install antenna tube as shown.**

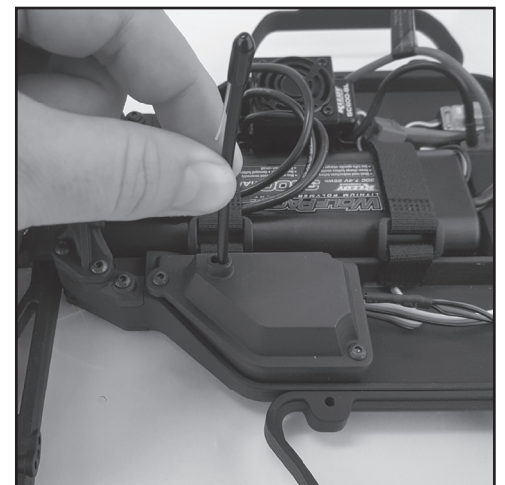

## :: Quick Start Guide - (cont.)

### Battery Notes and Tip:

Connect the battery as shown.  
Disconnect the battery when not in use!

**LiPo:** LiPo batteries (lithium polymer) are high current rechargeable batteries. LiPo batteries offer extended run time and peak performance over NiMH batteries. They require a peak detection charger designed specifically for LiPo batteries. These batteries require special care and handling. LiPo batteries are recommended for advanced users only!  
**ALWAYS** charge a LiPo battery in LiPo mode.

If using a 3S LiPo battery, use a smaller pinion gear as a starting point (use part # 1335 17T Pinion). This provides the gear ratio suggested for the more powerful 3S LiPo battery. Gearing will depend on the surface you are running on, and the size of the track/area that you are driving in.

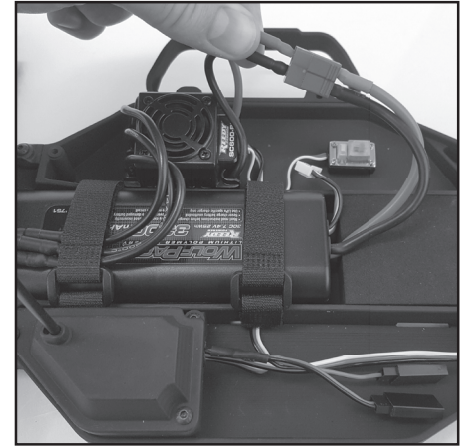

### Radio System Tuning and Controls:

**RULE:** Transmitter on First/Vehicle on Second,  
Vehicle off First/ Transmitter off Last!

- 1) Slide the battery cover to remove cover.
- 2) Install alkaline or rechargeable AA size batteries into the battery holder.
- 3) Slide the battery cover back into place making sure it is completely closed and secure.
- 4) Turn the power ON. If the power indicator LED fails to light, check the batteries for insufficient contact or incorrect polarity.

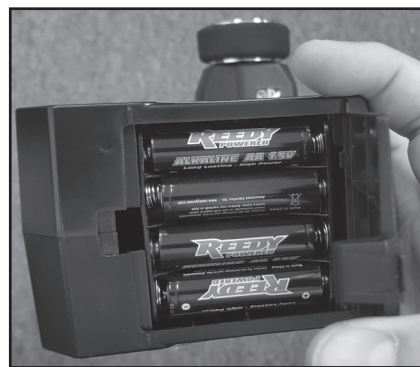

On/Off Switch

## :: Quick Start Guide - (cont.)

### Radio System Tuning and Controls:

**DO NOT** hold the trigger when turning on the radio.

If using optional battery for transmitter, be sure to plug it in correctly. Plugging in a battery backwards can cause damage.

Refer to Radio owners manual for more in-depth instructions on radio operation and functions.

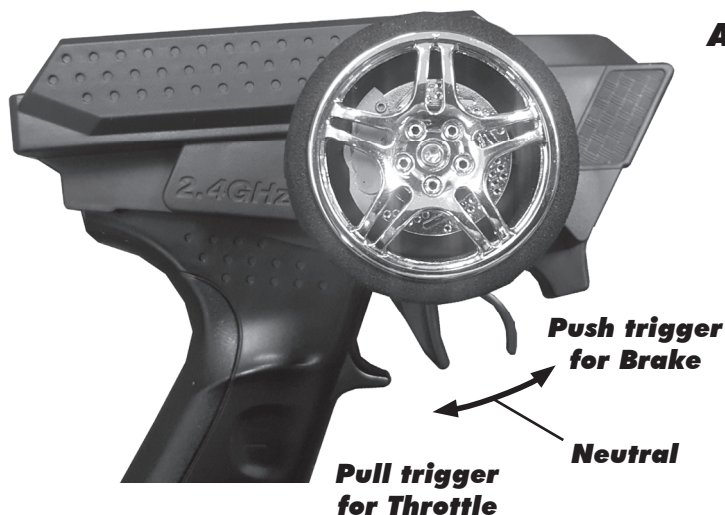

**Throttle set to Neutral!**

**Adjust steering trim so front wheels point straight.**

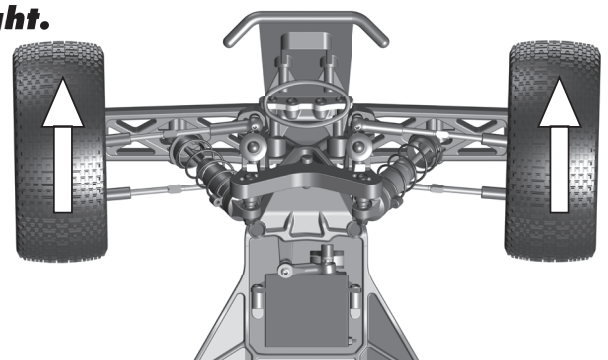

**Install body and body clips. Ready to go!**

**:: Front Top Plate and Steering Build - Step 1**

**91047**  $\Sigma 2$   
Heavy-duty Ballstud, 6mm

**91475**  $\Sigma 4$   
3 x 7 x 3 Ball Bearing

**91391**  
Steering Rack

**91391**  $\Sigma 2$   
Steering Rack Crush Tube

**91391**  
Steering Bellcrank Brace

**89202**  $\Sigma 2$   
M3 x 12mm BHCS

**91047**  
Heavy-duty Ballstud, 6mm

Note orientation of steering rack.

Do not over-tighten steering bolts. Make sure there is free movement in the steering rack.

**:: Front Top Plate and Steering Build - Step 2**

Note orientation of the brace.

**91475**  $\Sigma 4$   
3 x 7 x 3 Ball Bearing

**91391**  
Steering Bellcrank Brace

**25189**  $\Sigma 2$   
M3 x 22mm BHCS

**91358**  
Chassis Brace Set (Top Plate)

**:: Front Top Plate and Steering Build - Step 3**

**25202**  $\Sigma 2$   
M3 x 10mm FHCS

**91359**  
Bulkhead

**71092**  
Chassis

**25204**  $\Sigma 2$   
M3 x 16mm FHCS

**:: Front Suspension Build - Step 1**

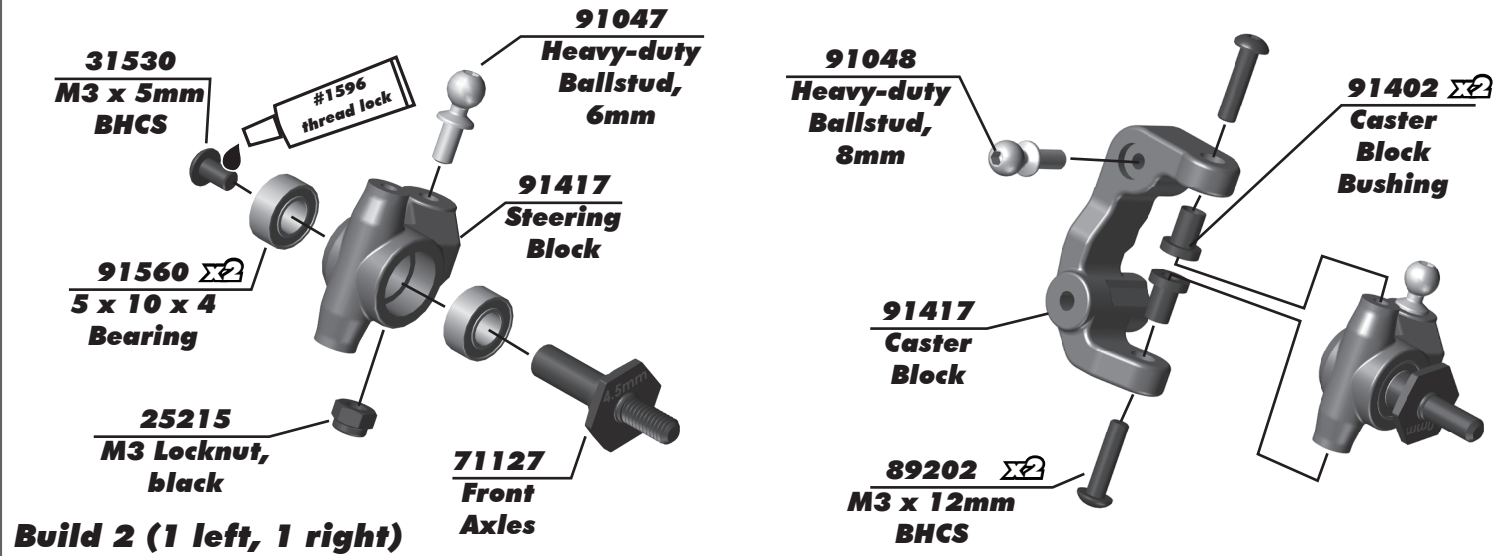

**:: Front Suspension Build - Step 2**

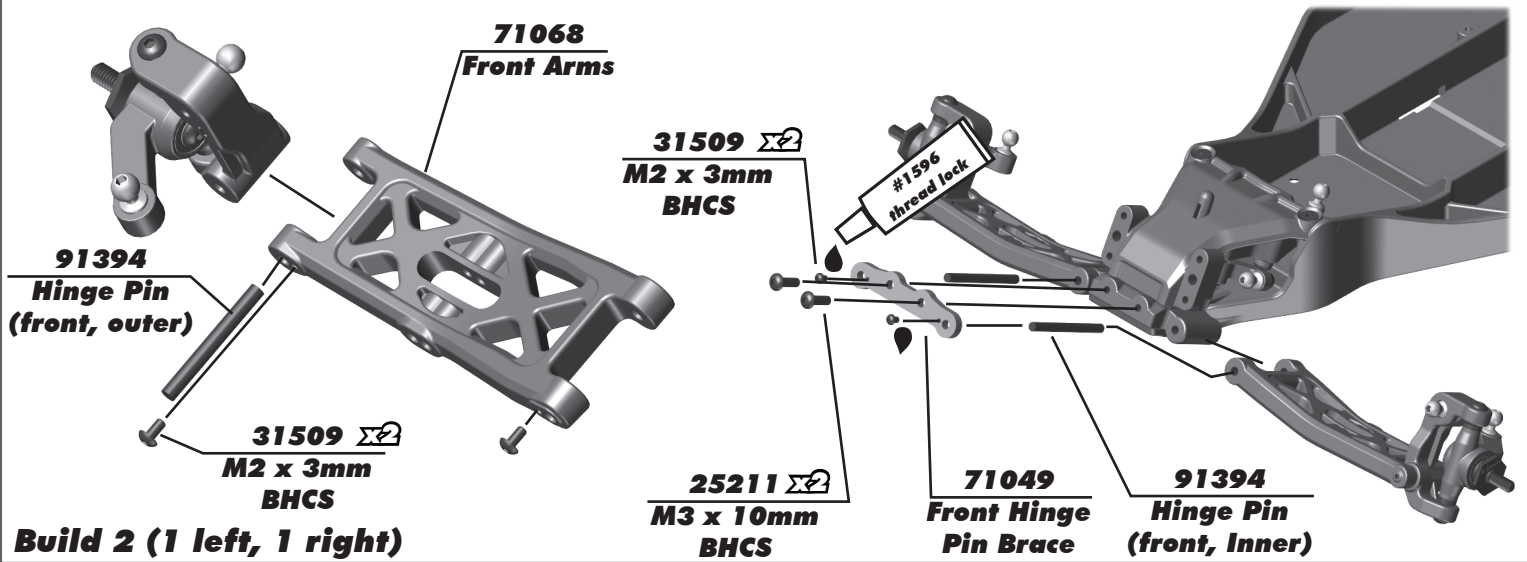

**:: Front Suspension Build - (LT10, DK10) - Step 3**

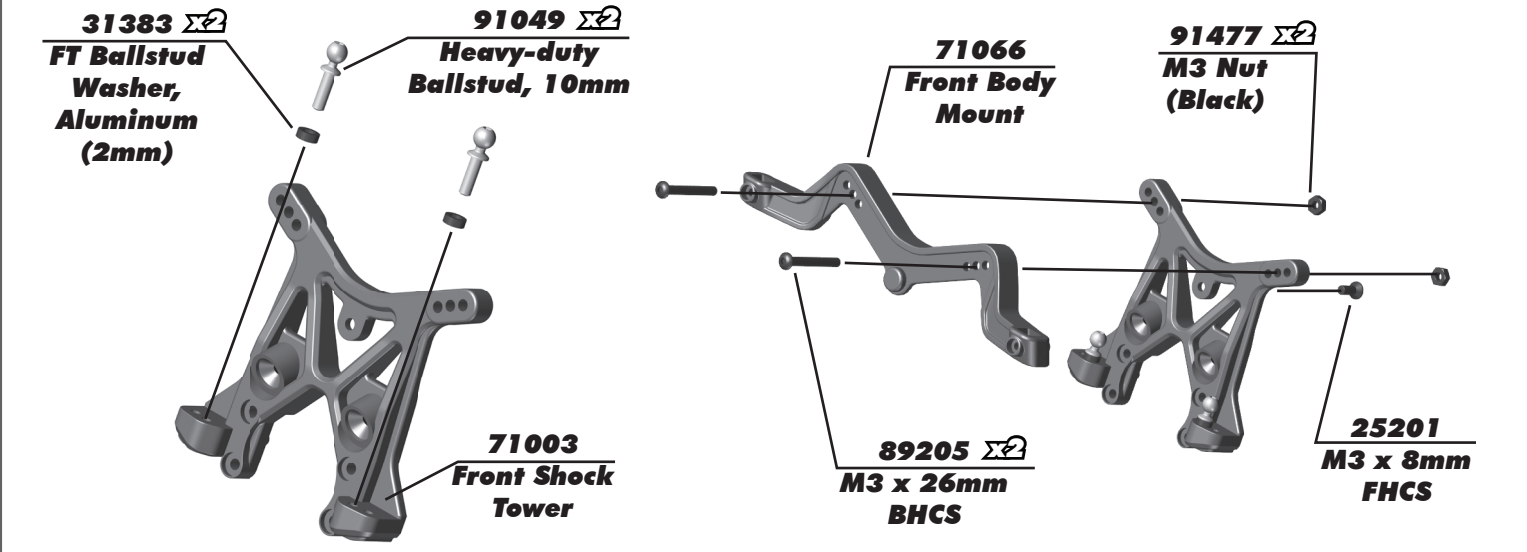



**:: Front Suspension Build - (RT10) - Step 4**

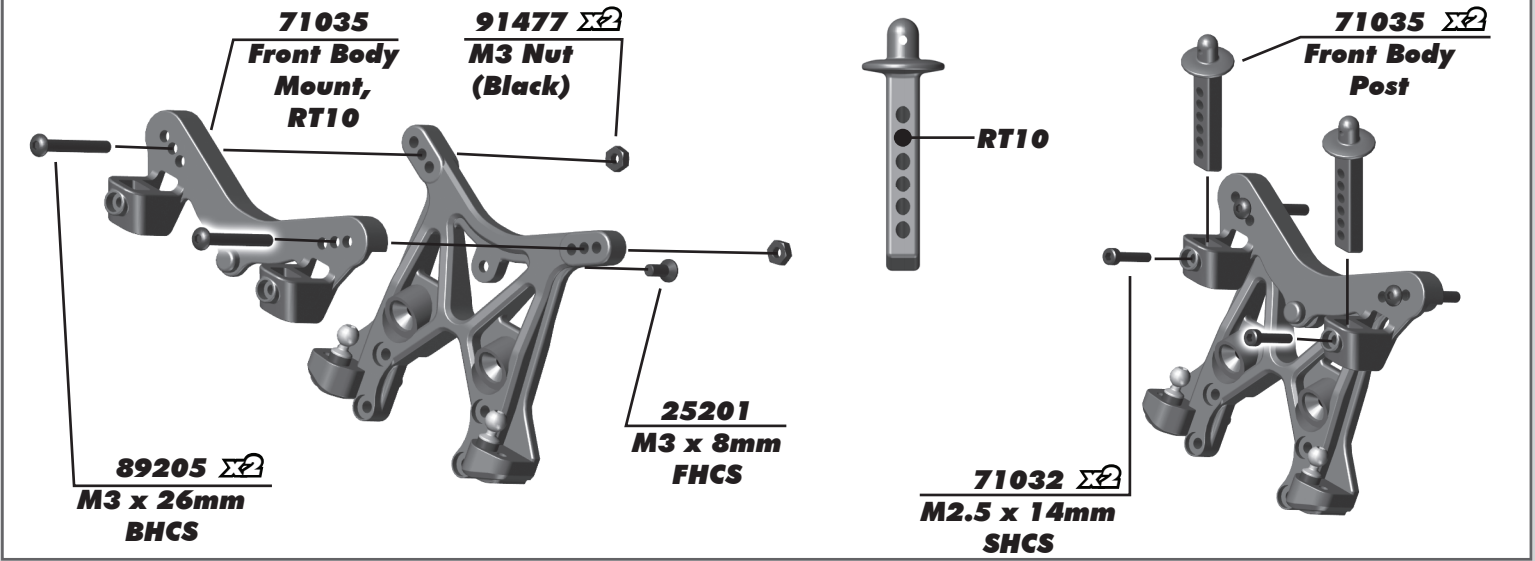

**:: Front Suspension Build - (LT10, DK10) - Step 4**

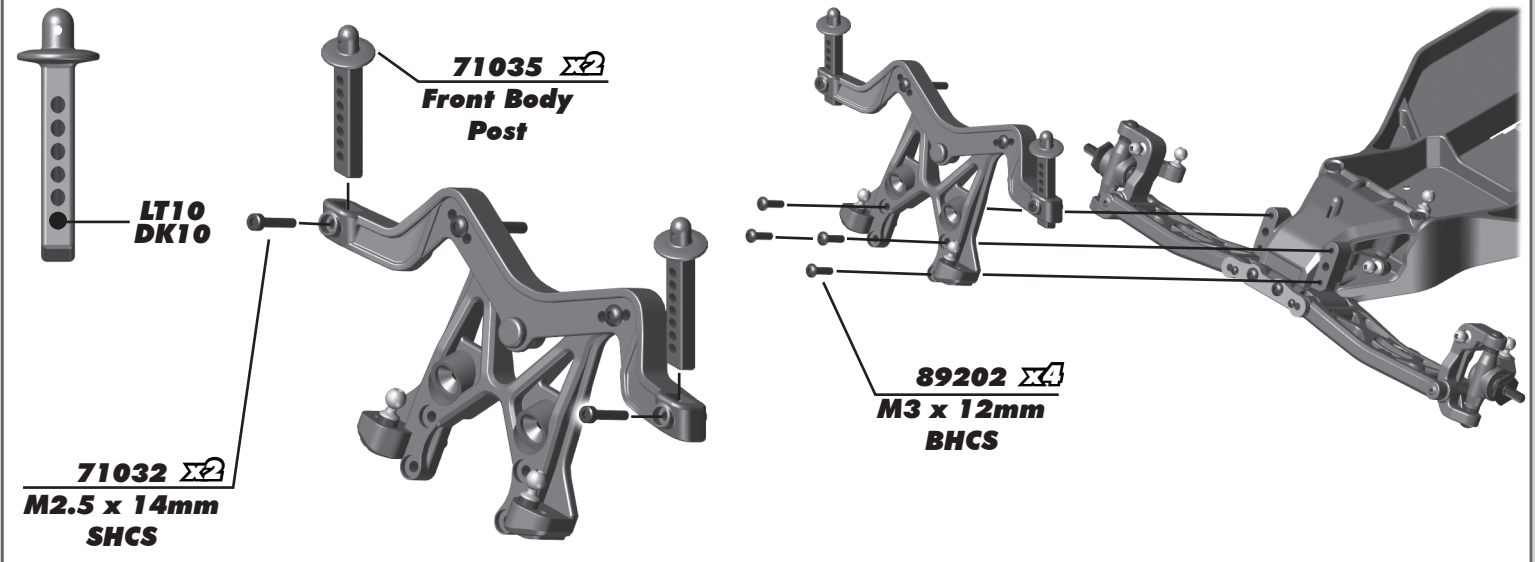

**:: Rear Suspension Build - Step 1**

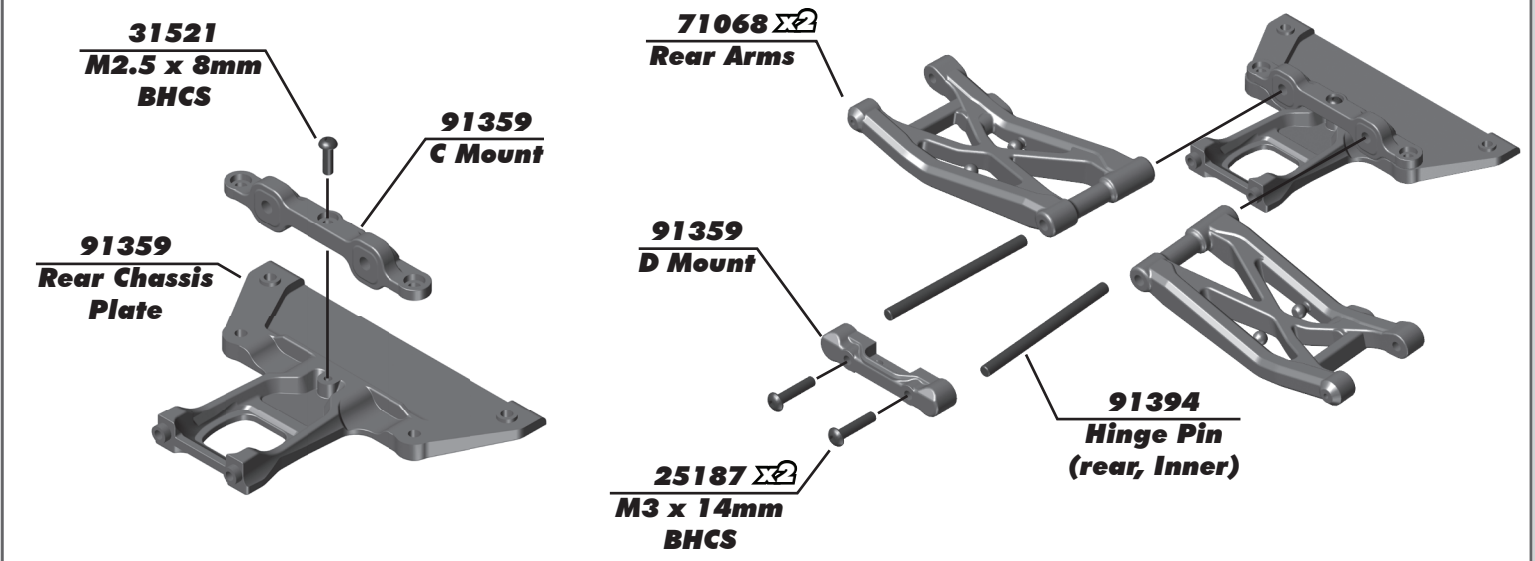

**:: Rear Suspension Build - Step 2**

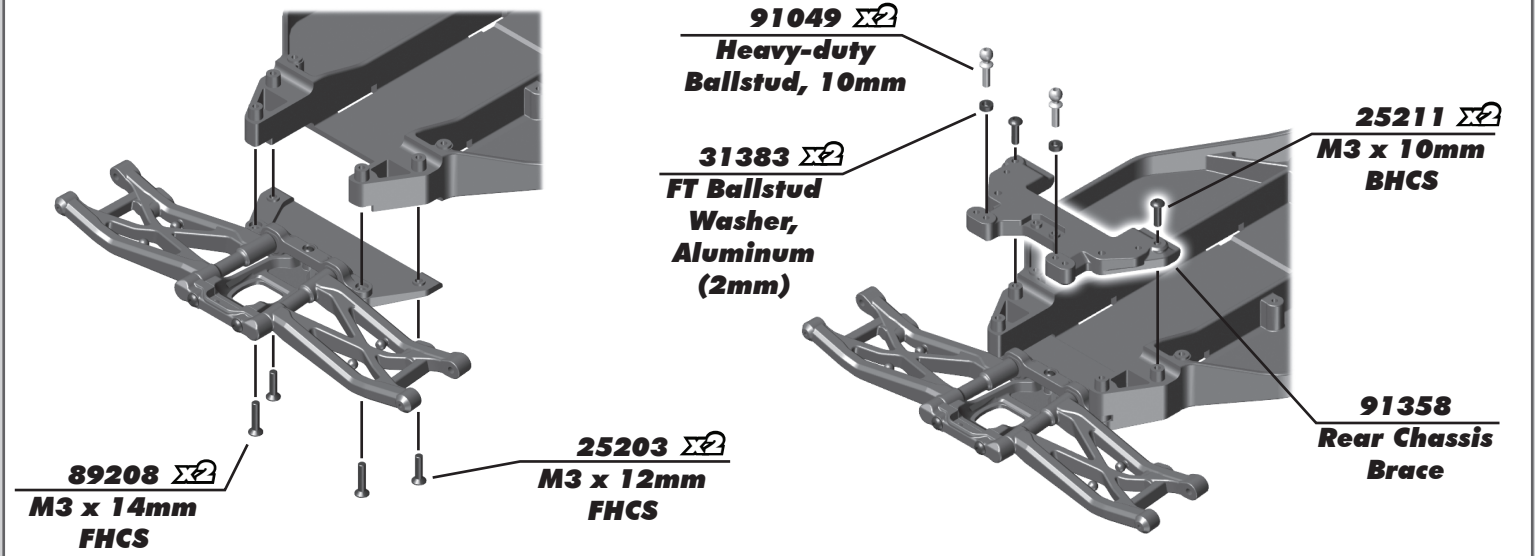

**:: Rear Suspension Build - Step 3**

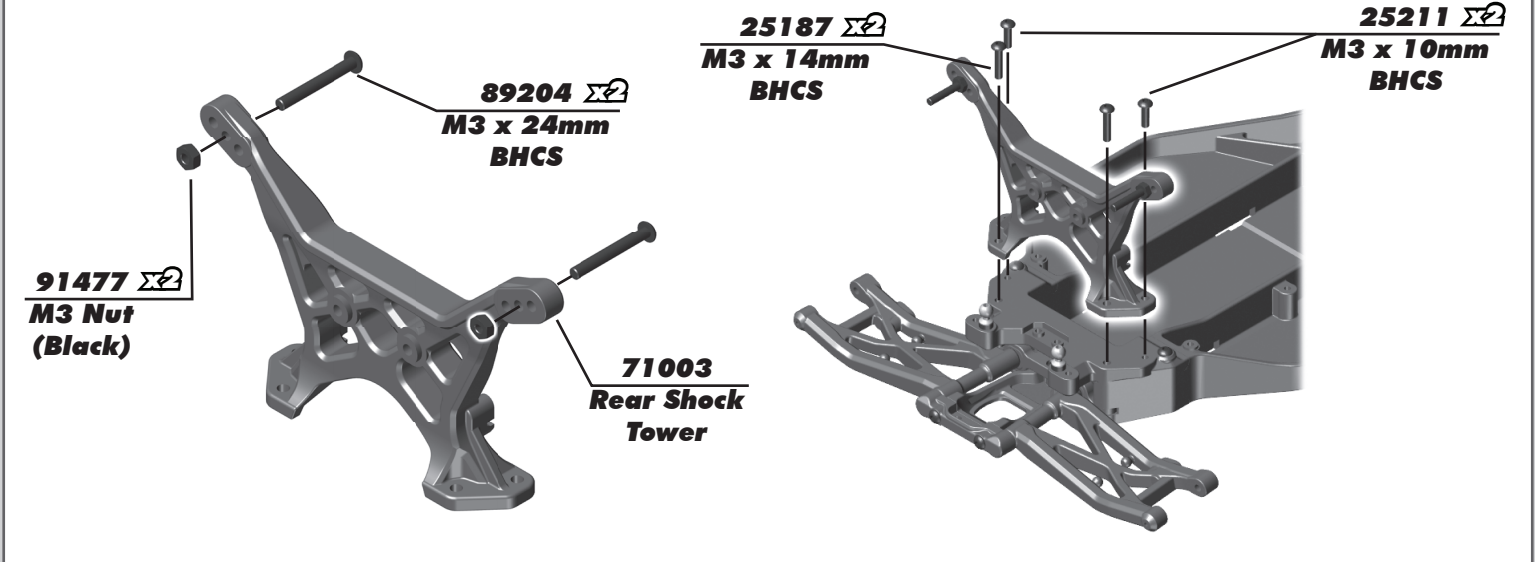

**:: Gear Diff Build - Step 1**

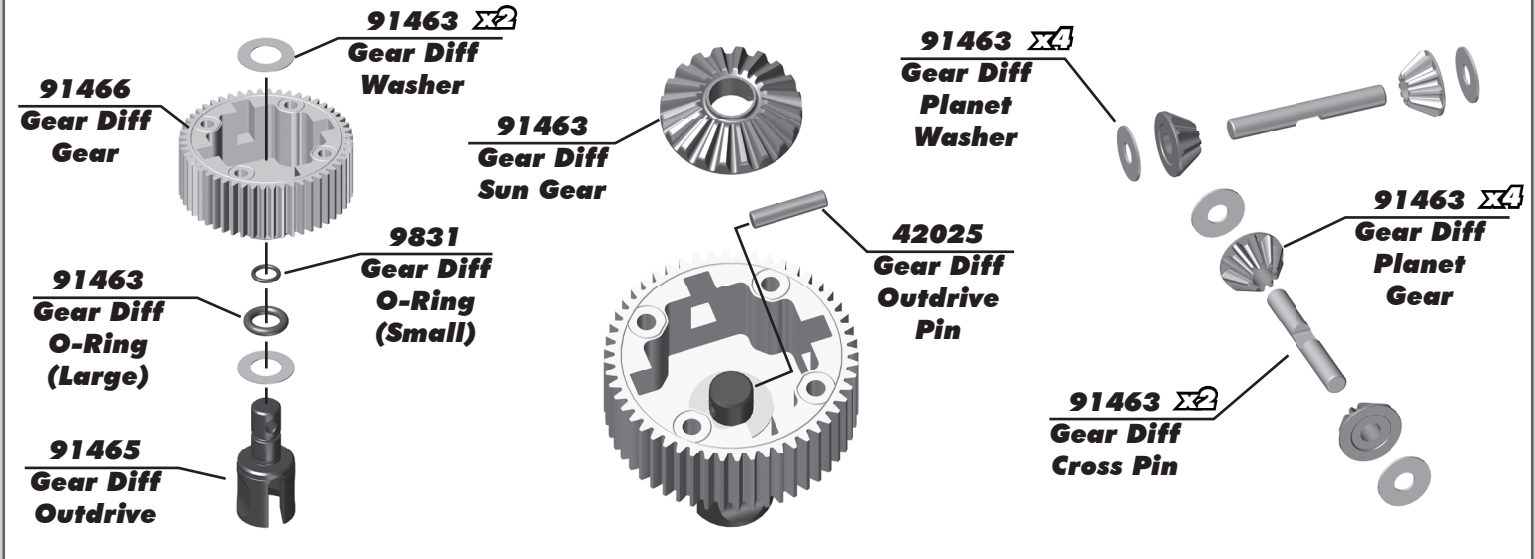

**:: Gear Diff Build - Step 2**

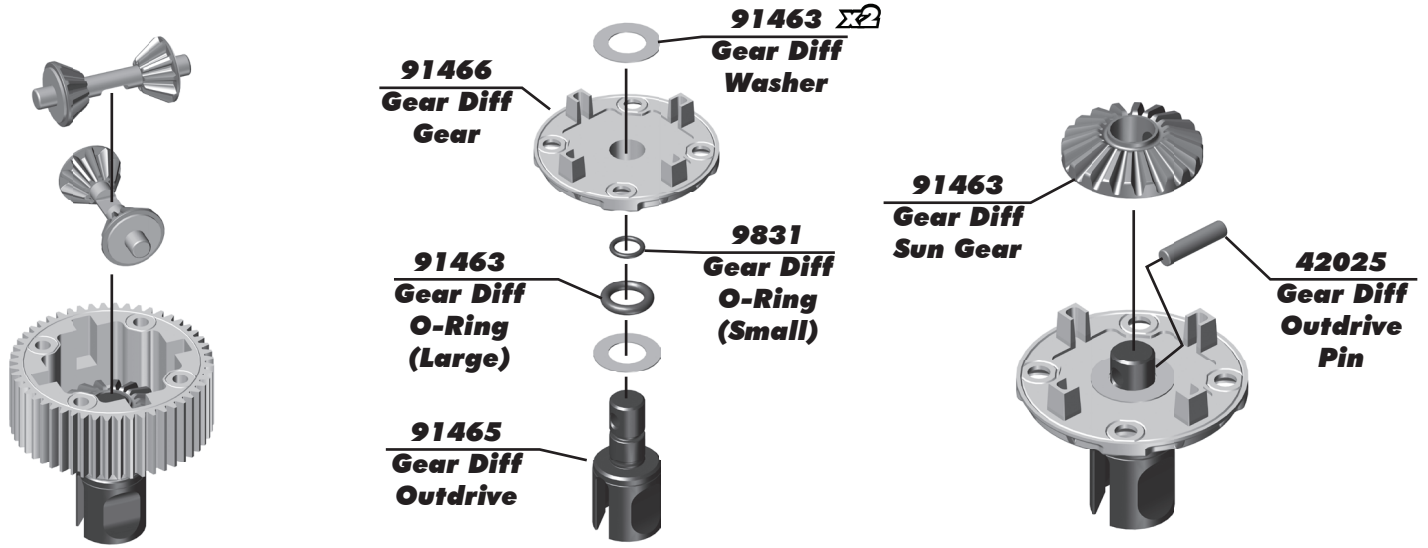

**:: Gear Diff Build - Step 3**

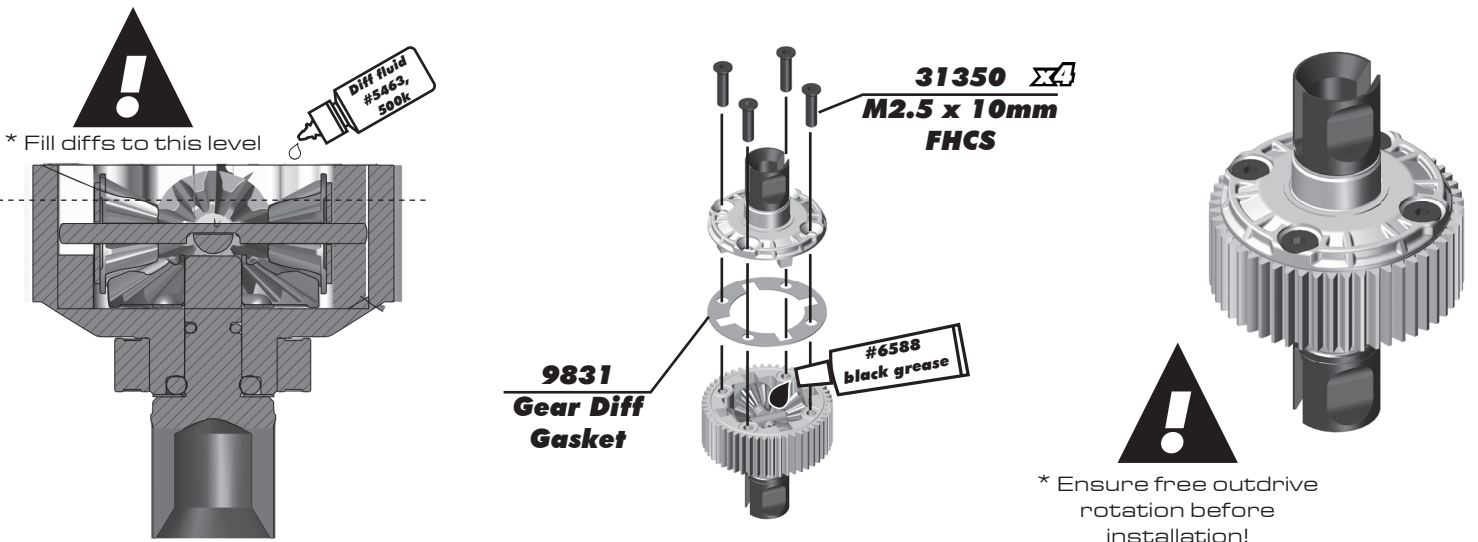

**:: Gearbox Build - Step 1**

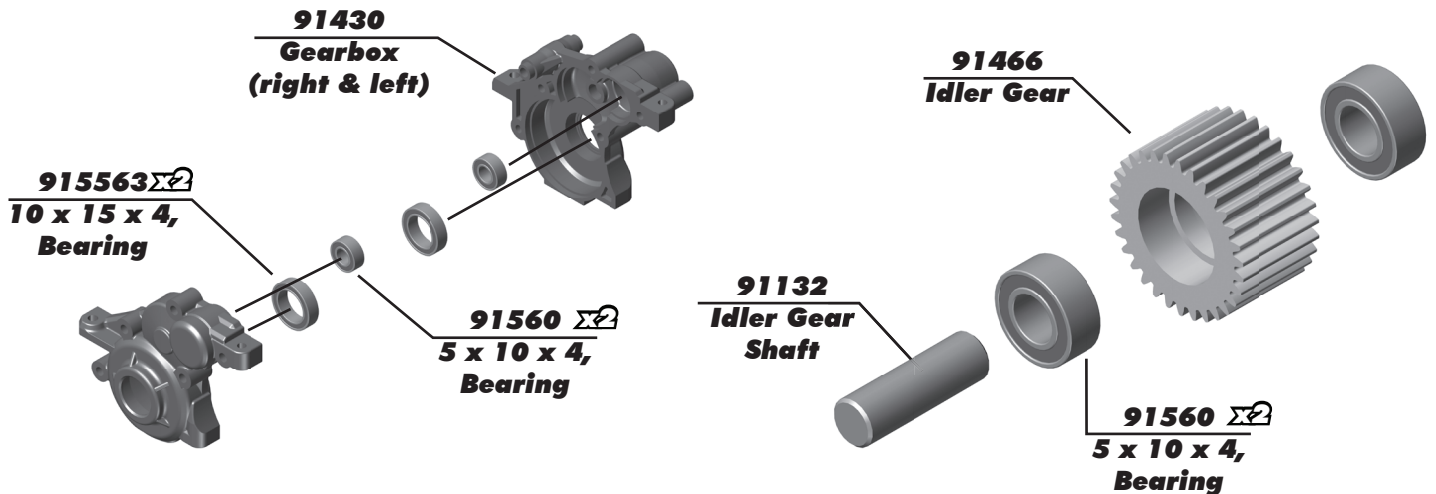

**:: Gearbox Build - Step 2**



Add a drop of Diff Lube (#6591) to the teeth of the diff gear, idler gears, and top shaft.

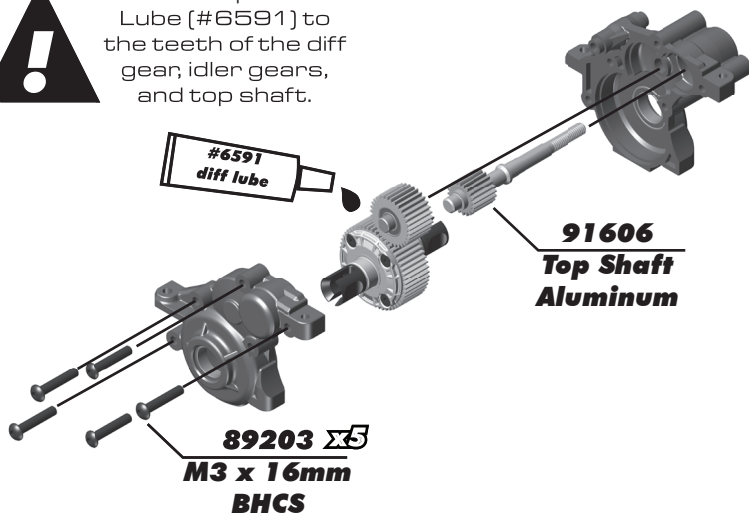

31532  $\Sigma 2$   
M3 x 8mm  
BHCS

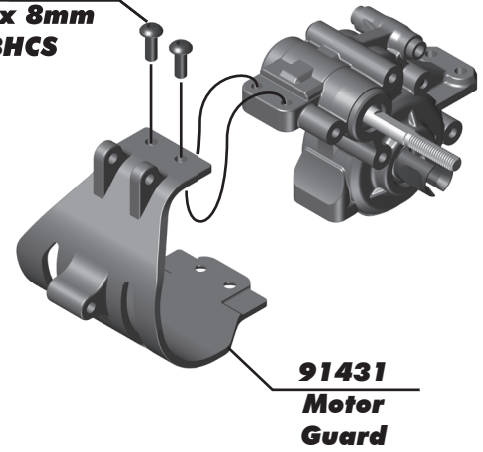

**:: Gearbox Build - Step 3**

91478  $\Sigma 2$   
M3 x 30mm  
FHCS

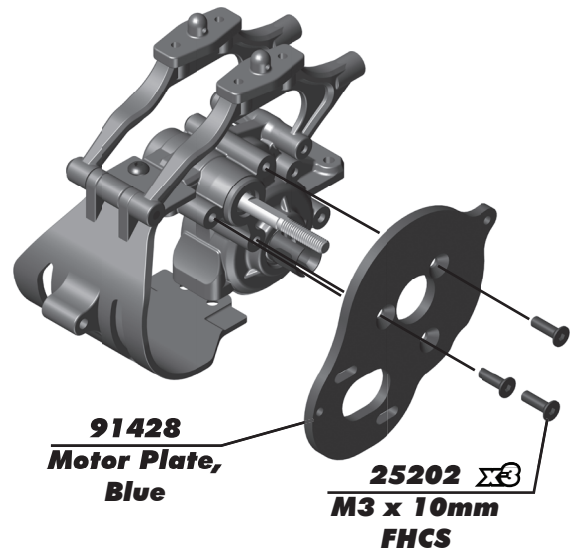
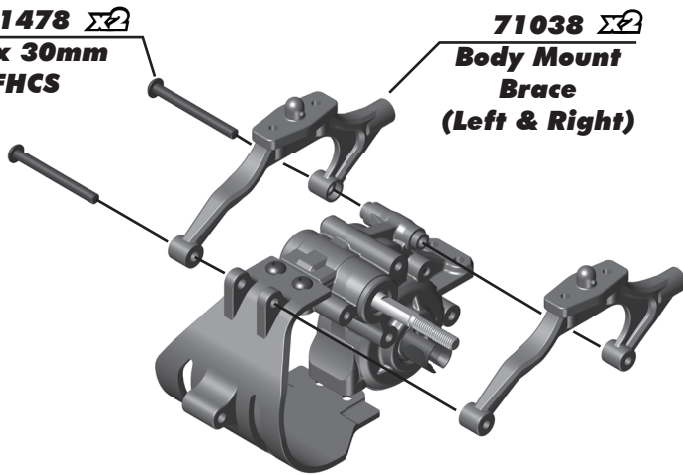

**:: Slipper Build - Step 1**

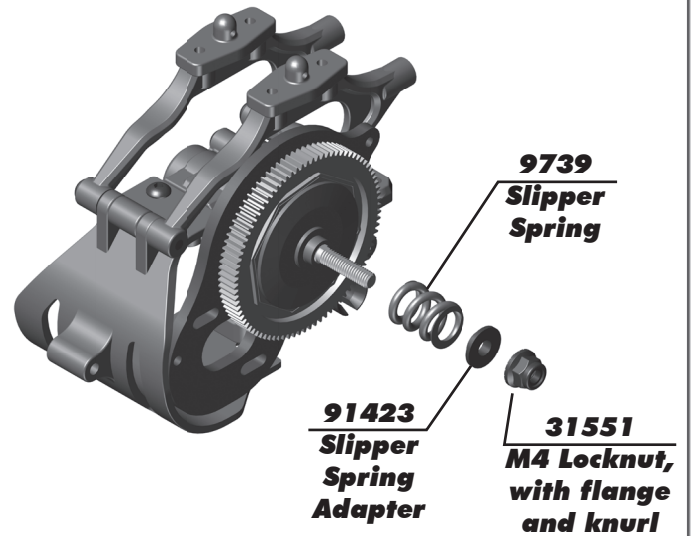
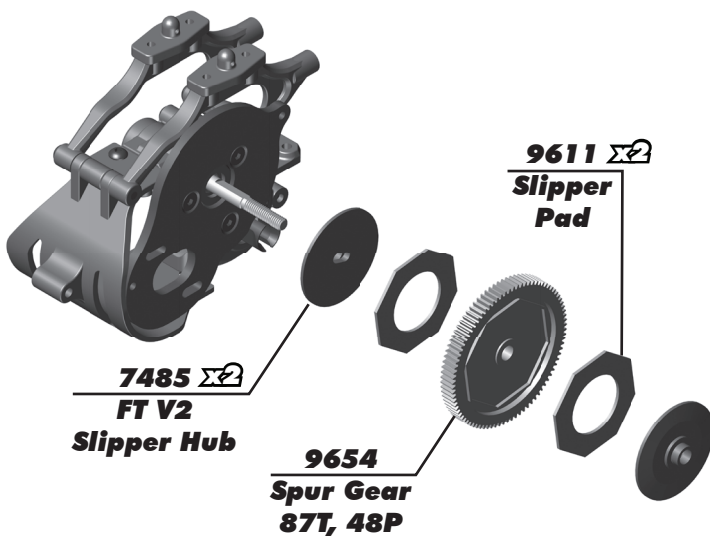

**:: Gearbox Install - Step 1**

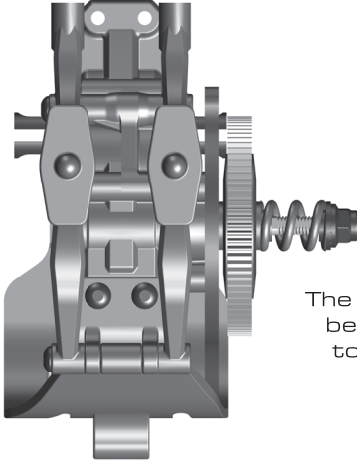

The Locknut should be flush with the top shaft when installed.

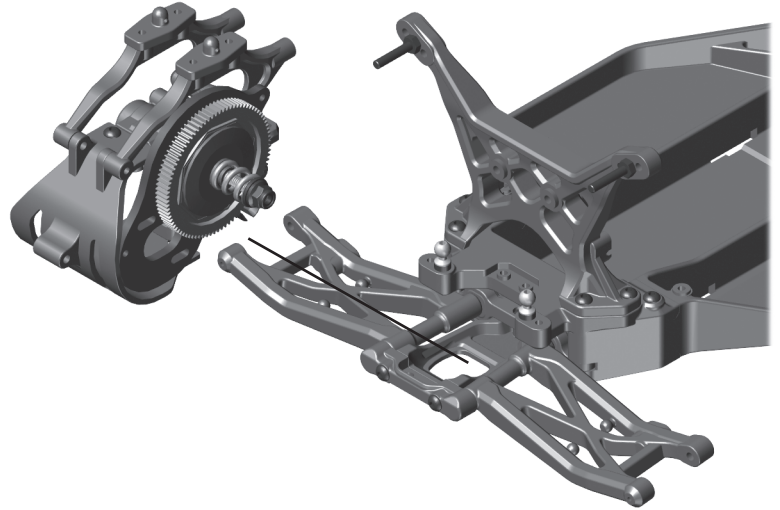

See page 23 for gear mesh, and slipper clutch setting instructions!

**:: Gearbox Install - Step 2**

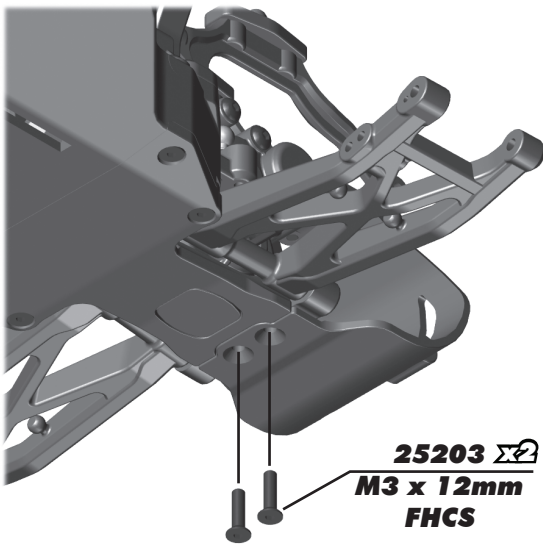

**25203**   
 M3 x 12mm   
 FHCS

**25211**   
 M3 x 10mm   
 BHCS

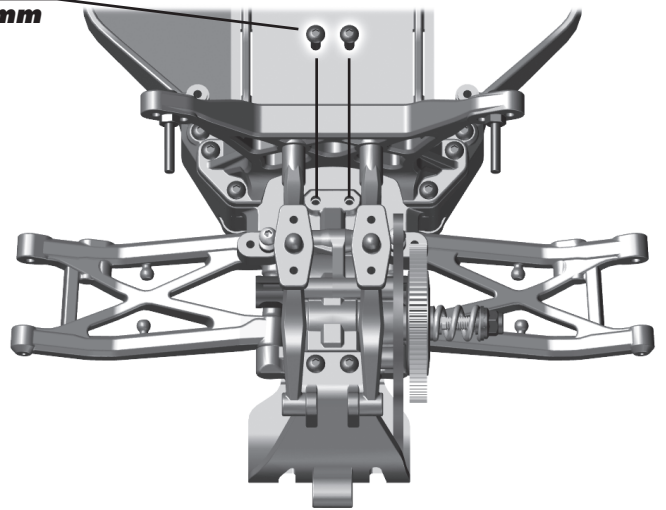

**:: Gearbox Install - Step 3**

**25204**   
 M3 x 16mm   
 FHCS

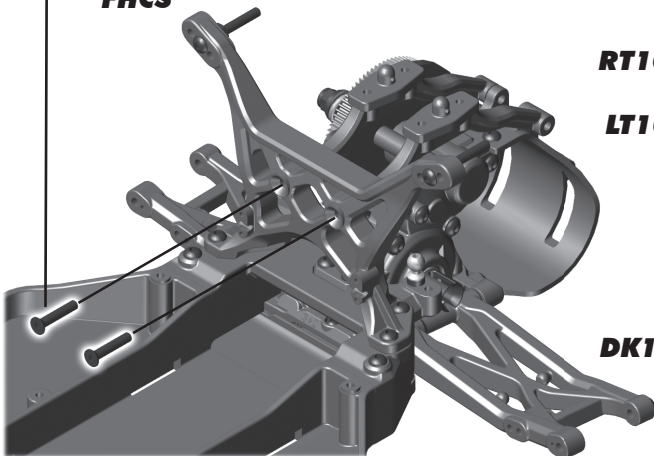

RT10 ●   
 LT10 ●   
 DK10 ●



**25202**   
 M3 x 10mm   
 FHCS

**71038**   
 Rear Body   
 Mount

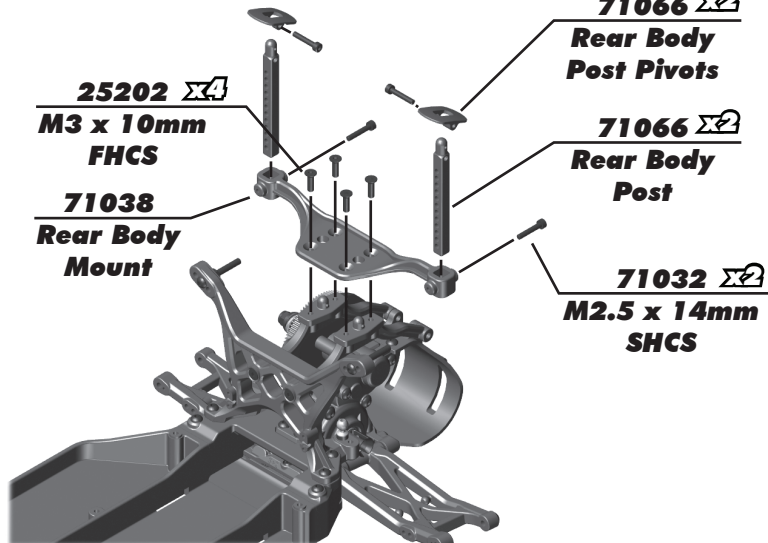

**71066**   
 Rear Body   
 Post Pivots

**71066**   
 Rear Body   
 Post

**71032**   
 M2.5 x 14mm   
 SHCS

**:: Rear Hub and CVA Build - Step 1**

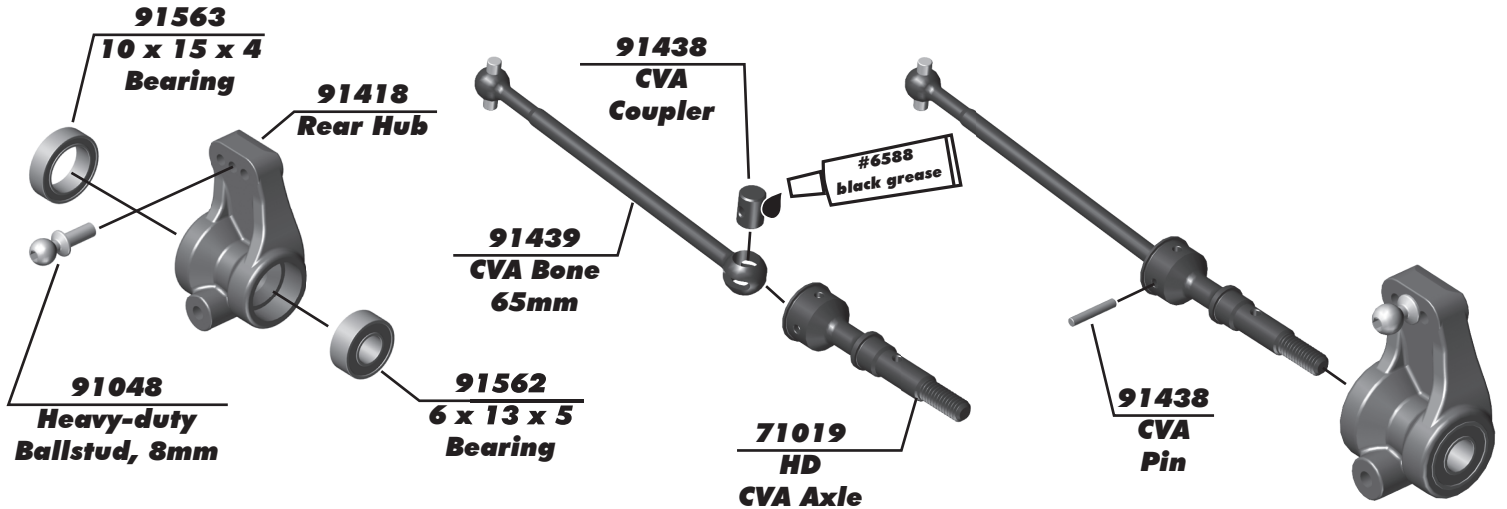

**Build x2 (right and left side)**

**Build x2 (right and left side)**

**:: Rear Hub and CVA Build - Step 2**

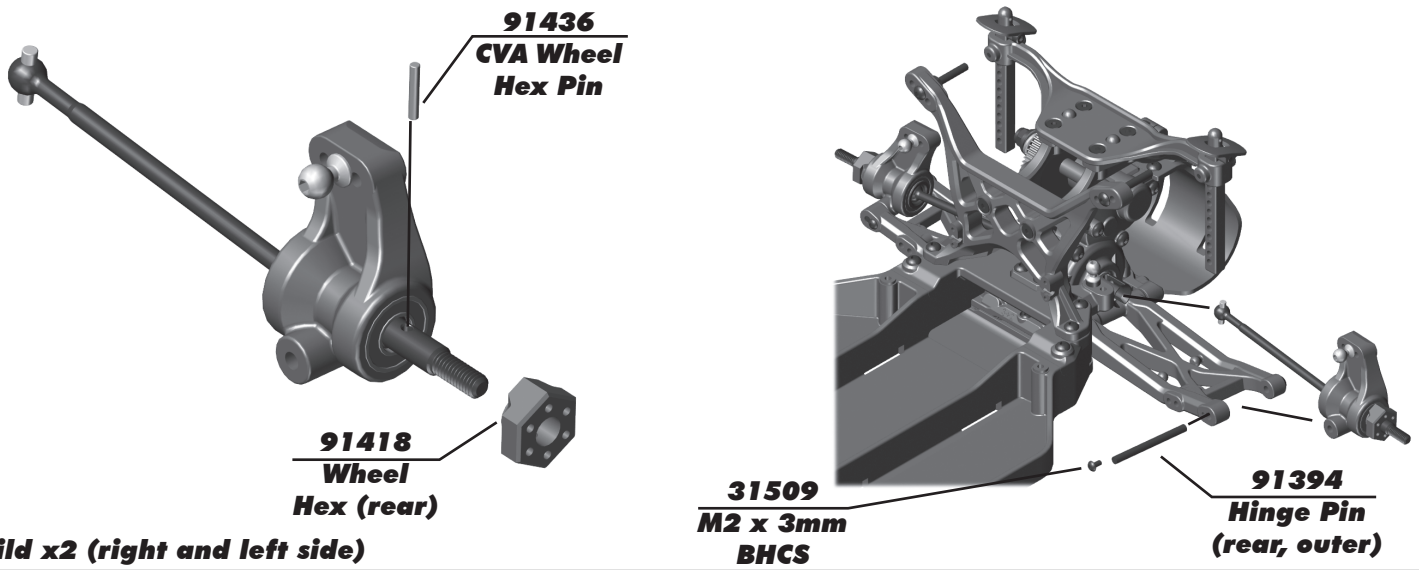

**Build x2 (right and left side)**

**:: Turnbuckles Build - Step 1**

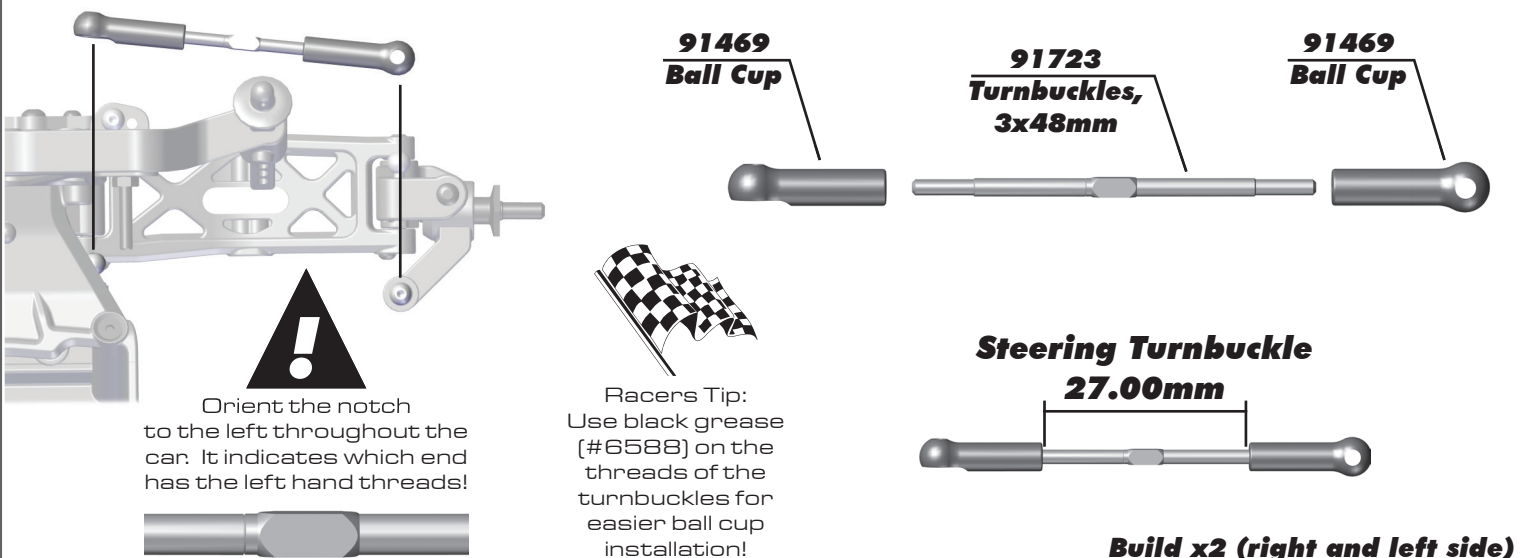

**!**  
Orient the notch to the left throughout the car. It indicates which end has the left hand threads!

**Checkered Flag**  
Racers Tip: Use black grease (#6588) on the threads of the turnbuckles for easier ball cup installation!

**Build x2 (right and left side)**

**:: Turnbuckles Build - Step 2**

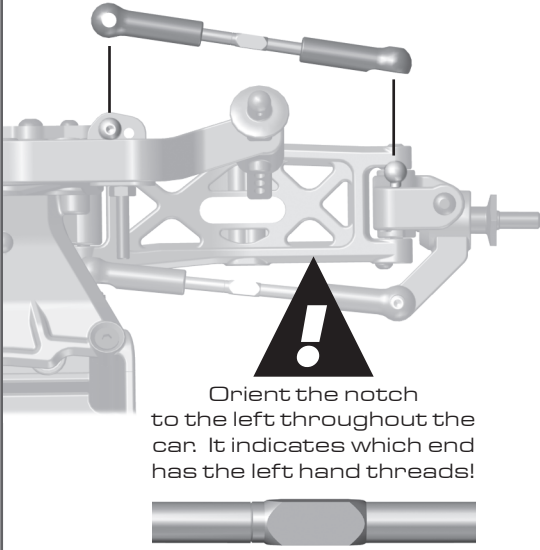

Orient the notch to the left throughout the car. It indicates which end has the left hand threads!



**91469**  
**Ball Cup**

**91723**  
**Turnbuckles,**  
**3x48mm**

**91469**  
**Ball Cup**



Racers Tip:  
Use black grease (#6588) on the threads of the turnbuckles for easier ball cup installation!

**Front Camber Turnbuckle**  
**23.00mm**

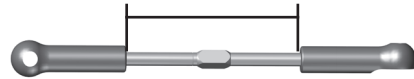

**Build x2 (right and left side)**

**:: Turnbuckles Build - Step 3**

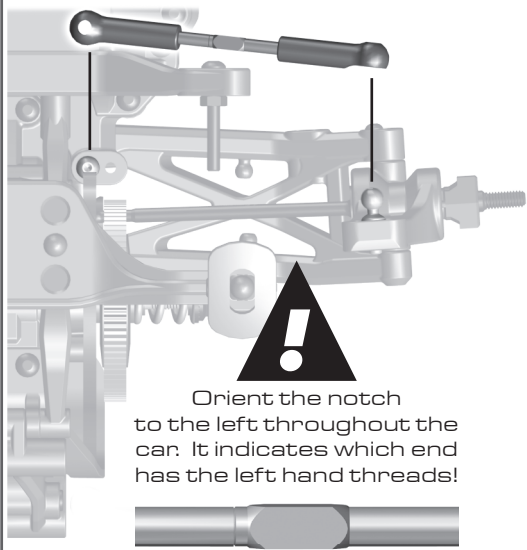

Orient the notch to the left throughout the car. It indicates which end has the left hand threads!

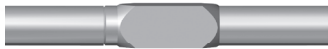

**91469**  
**Ball Cup**

**91723**  
**Turnbuckles,**  
**3x48mm**

**91469**  
**Ball Cup**



Racers Tip:  
Use black grease (#6588) on the threads of the turnbuckles for easier ball cup installation!

**Rear Camber Turnbuckle**  
**23.50mm**

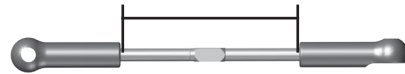

**Build x2 (right and left side)**

**:: Shocks Build - Step 1**

**91444**  
**12mm**  
**Shock Piston**

**6299**  
**1/8 E-Clip**

**91489**  
**3 x 27.5**  
**Shock Shaft**  
**(front)**

**91490**  
**3 x 35**  
**Shock Shaft**  
**(rear)**



Racers Tip:

Use a marker over the numbers on the pistons to make them easily visible!

**6299**  
**1/8 E-Clip**



**:: Shocks Build - Step 2**

**71051 Shock Body 12 x 27.5mm (front)**

**71052 Shock Body 12 x 36mm (rear)**

**91444 Shock Internals**

**91454 Shock Bottom Cap**

**31327 Shock Bottom Cap O-Ring**

**5407 O-Ring**

**91491 Shock Cap O-Ring**

**91469 Shock eyelet**

**91469 Shock Pivot Ball**

**71086 6mm Spacer (Rear Only)**

**#1105 green slime**

Lightly rub shock oil on the o-ring before installation!

Racers Tip: Coating the o-rings with green slime (#1105) helps seal & reduce o-ring swell! **Green slime not included in kit!**

**:: Shocks Build - Step 3**

**Shock fluid #5422**

**91454 Shock Cap (Molded)**

**Front Shock: 30wt**  
**Rear Shock: 30wt**

**Shock Bleeding Steps:**

1. Pull shock shaft down.
2. Fill shock body 3/4 full with silicone fluid.
3. Slowly move the shock shaft up and down to remove air from under piston.
4. Wait for bubbles to come to surface.
5. Fill shock body to top with silicone fluid.
6. Place a drop of oil in the cap and on cap threads.
7. Install cap and tighten completely.
8. Slowly compress shaft all the way to the top. If there is pressure at the top of the stroke, there is too much oil or air. You must bleed it out.
9. Slowly pull shaft out.
10. Unscrew the cap 3/4 turn and tilt the shock at a slight angle.
11. Slowly compress the shaft to push out excess oil and air. You should see bubbles coming out from under the cap.
12. With the shaft compressed, tighten the cap and re-check for pressure at the top of the stroke. If there is still pressure, repeat steps 9 thru 11.

**Stroke**  
**Front: 26.0mm**  
**Rear: 35mm**

**Free Length**  
**Front: 86.25mm**  
**Rear: 103.50mm**

**Step 1-3**   **Step 3-4**   **Step 5-6**   **Step 7**   **Step 9-10**

**:: Shocks Build - Step 4**

**71054 Pre Load Spacers**

**71054 Spring Collar**

**91636 12mm front spring (54mm), White (4.10lb)**

**91639 12mm rear spring (72mm), Green (2.20lb)**

Pre-Load Spacers	
1mm	
2mm	
3mm	
5mm	

**Front Shocks None**   **Rear Shocks 5mm**

**91454 Spring Cup**

**Build x2 front and x2 rear shocks**



**:: Shocks Build - Step 5**



Use outside hole in front arm!

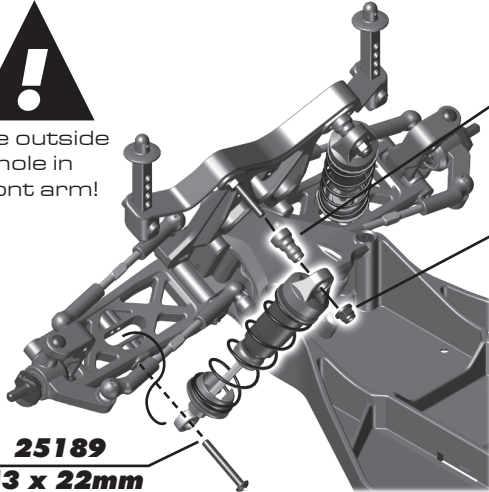

**25189**  
M3 x 22mm  
BHCS

Build x2 (right and left side)

**91444**  
Shock  
Bushing

**25612**  
M3 Locknut,  
with flange  
(black)

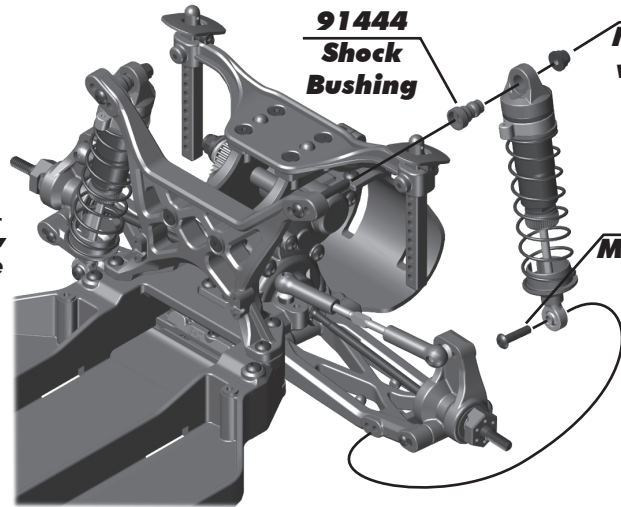

**91444**  
Shock  
Bushing

**25612**  
M3 Locknut,  
with flange  
(black)

**89202**  
M3 x 12mm  
BHCS



Use outside hole in rear arm!

Build x2 (right and left side)

**:: Electronics Build - Step 1**

**91047**  
Heavy-duty  
Ballstud, 6mm

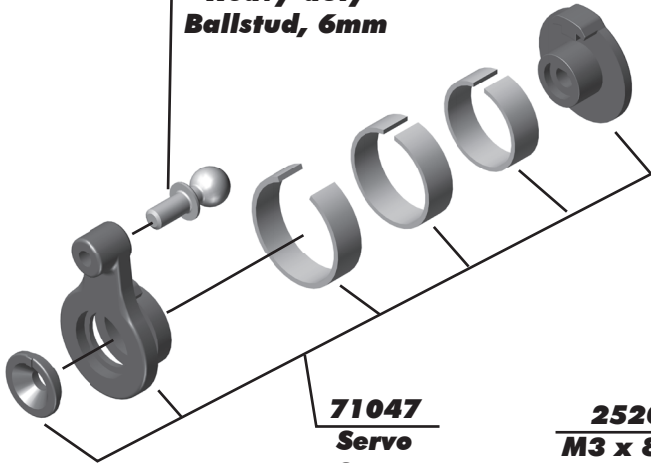

**71047**  
Servo  
Saver



Align the servo horn 90 degrees. Adjust steering trim once vehicle is complete.



**25201**  
M3 x 8mm  
FHCS

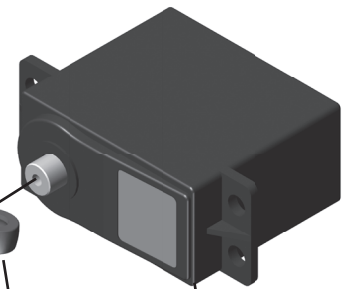

**91469**  
Steering  
Link

Servo

**:: Electronics Build - Step 2**

**91391** x2  
Servo  
Mount

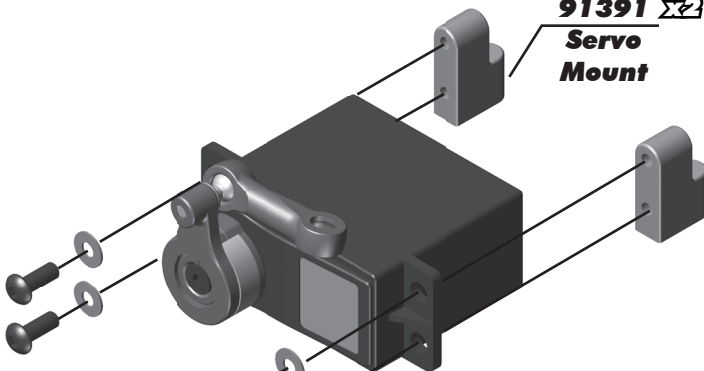

**31532** x4  
M3 x 8mm  
BHCS

**89218** x4  
3x8mm  
Washer

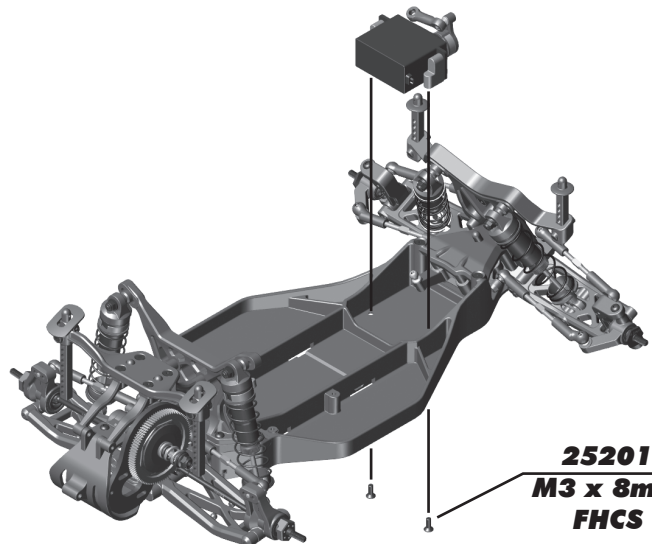

**25201** x2  
M3 x 8mm  
FHCS

**:: Electronics Build - Step 3**

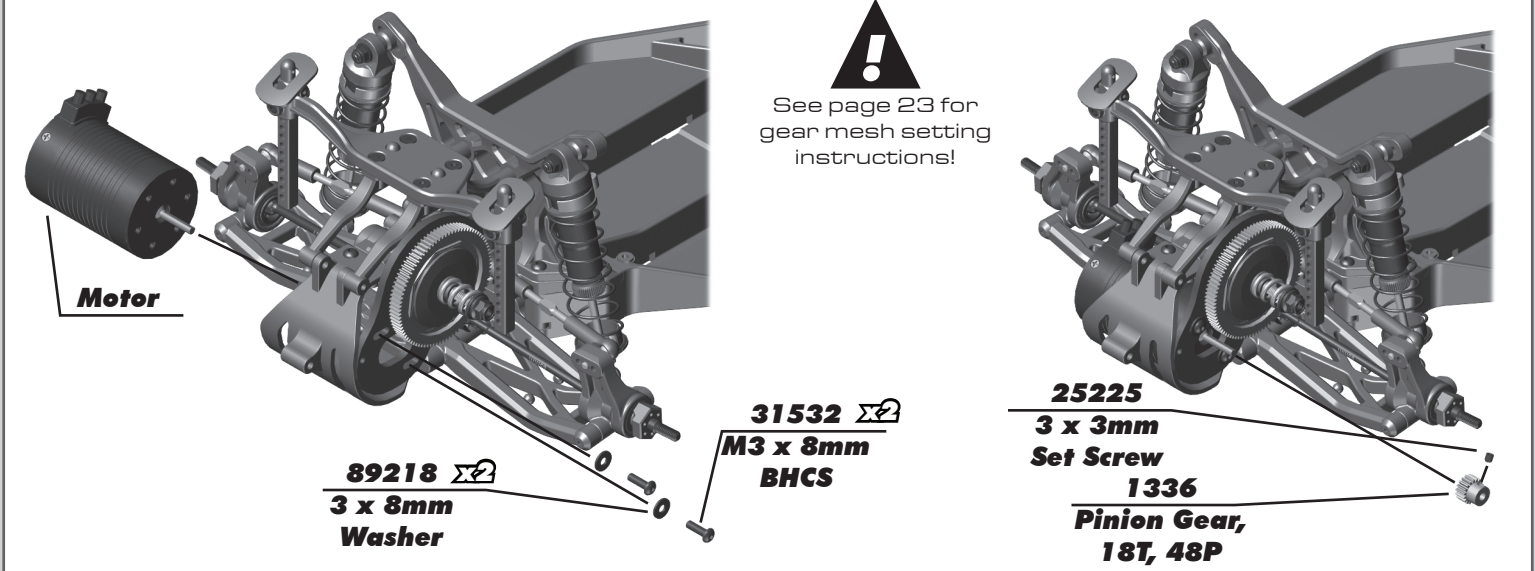

**:: Electronics Build - Step 4**

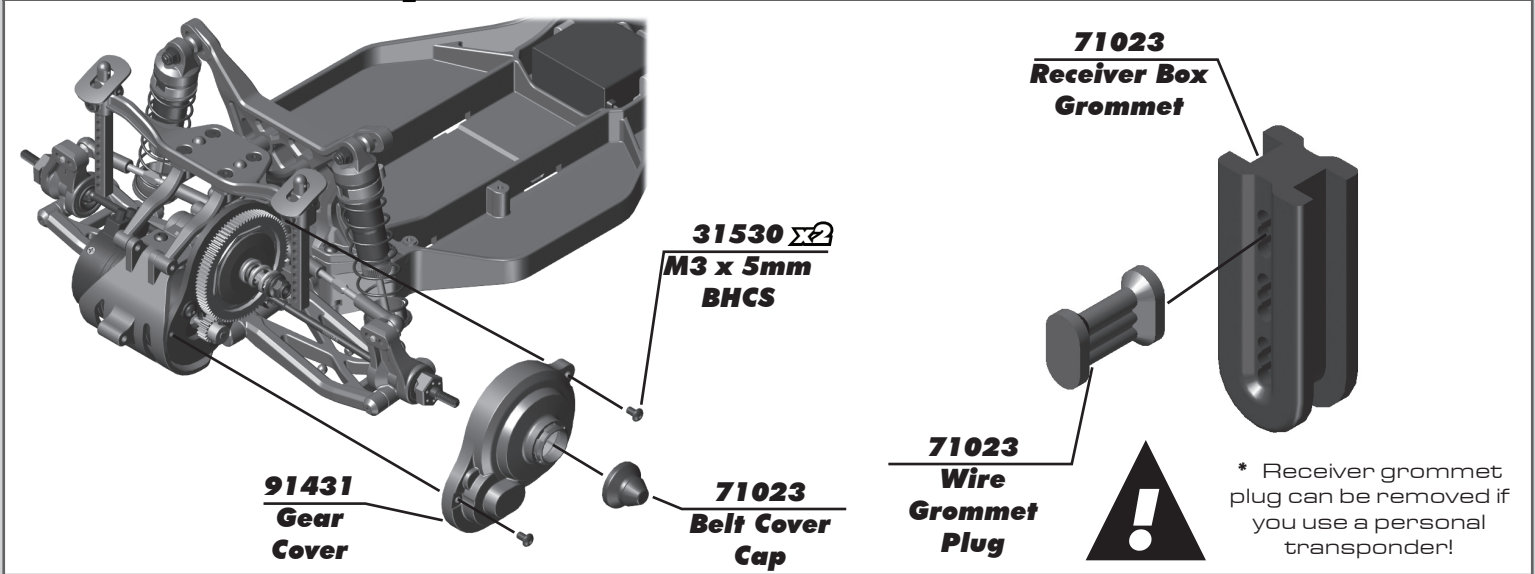

**:: Electronics Build - Step 5**

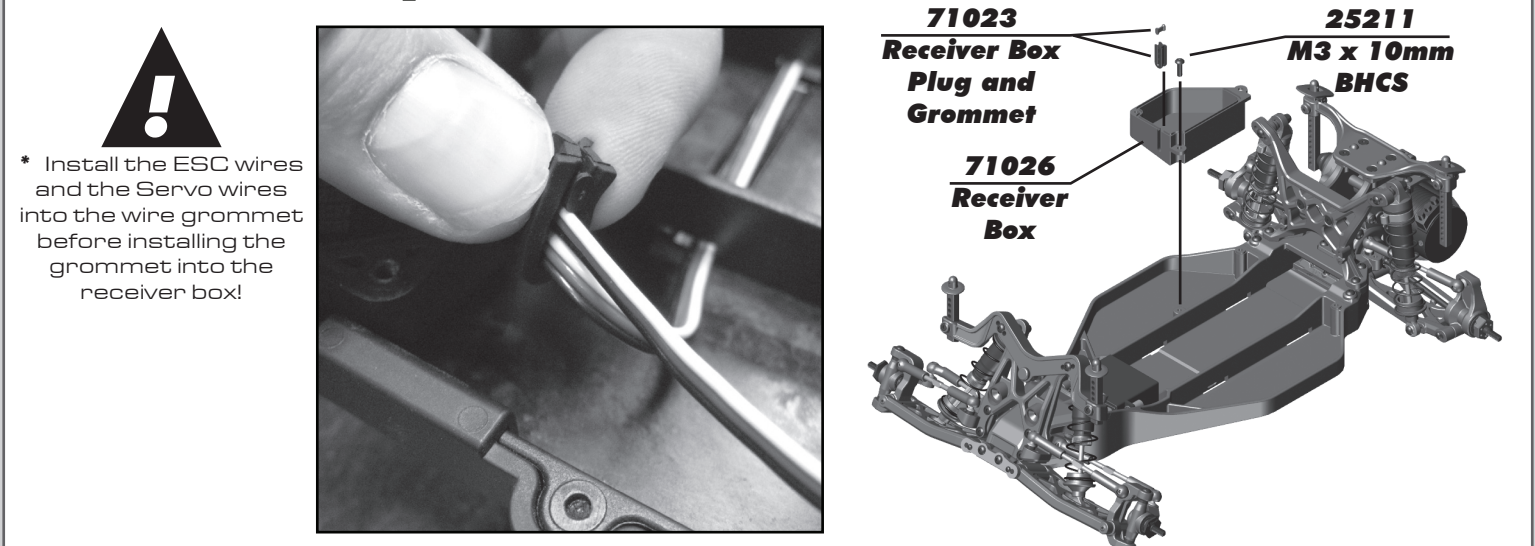

**:: Electronics Build - Step 6**

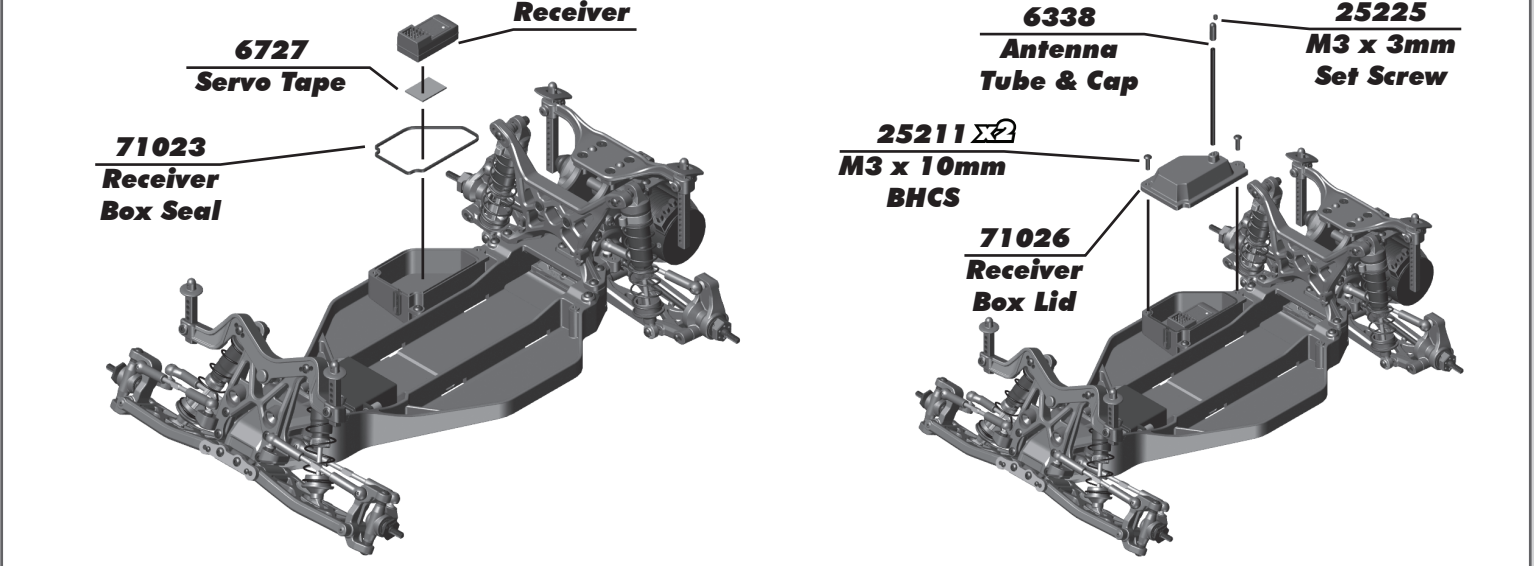

**:: Electronics Build - Step 7**

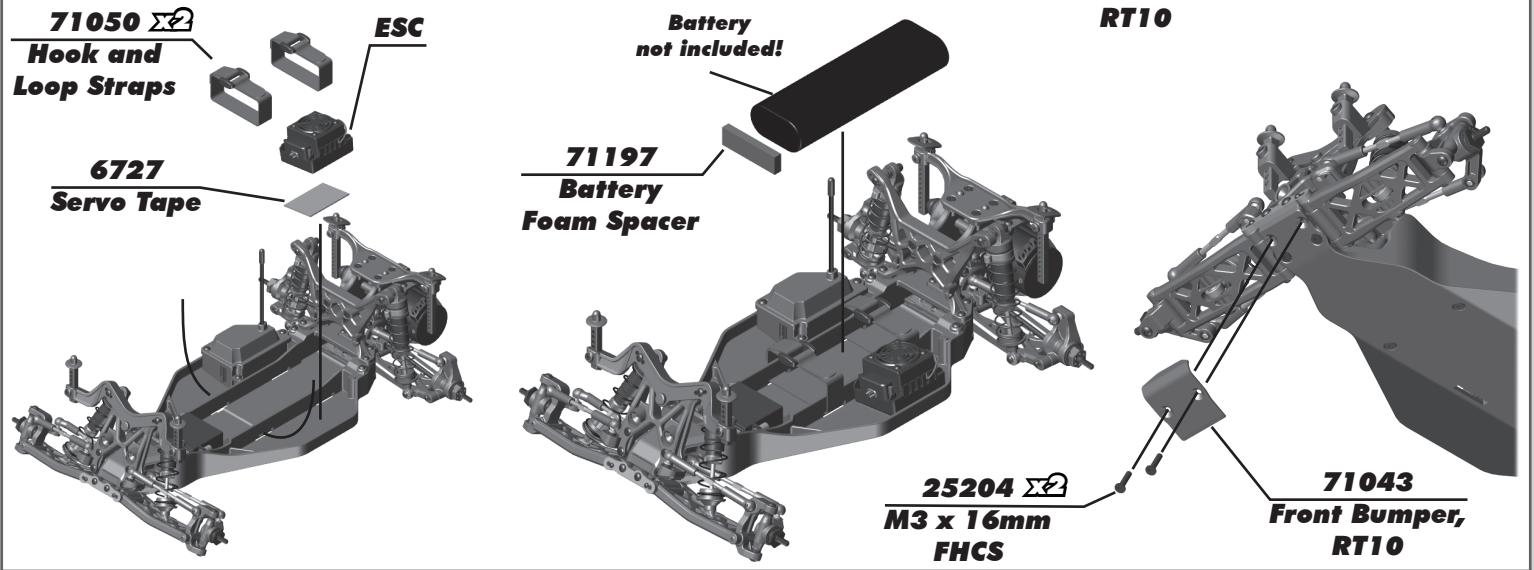

**:: Bumper and Chassis Braces Build - Step 1**

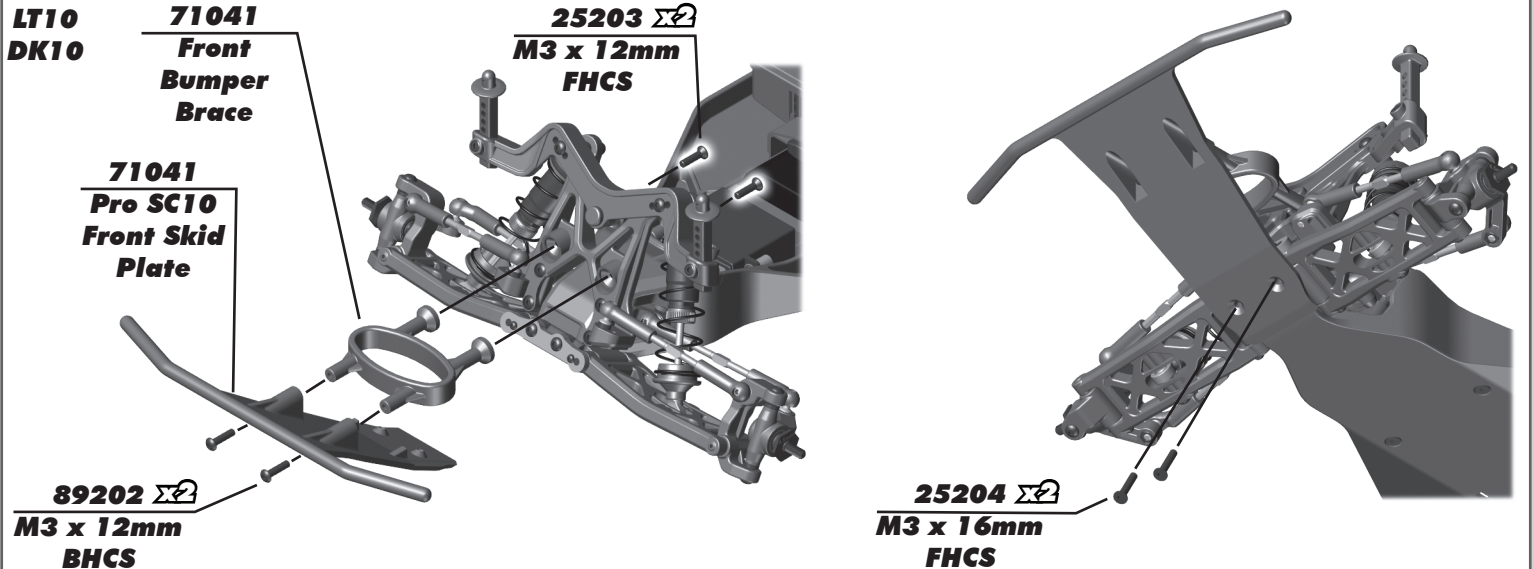

**:: Bumper and Chassis Braces Build - Step 2**

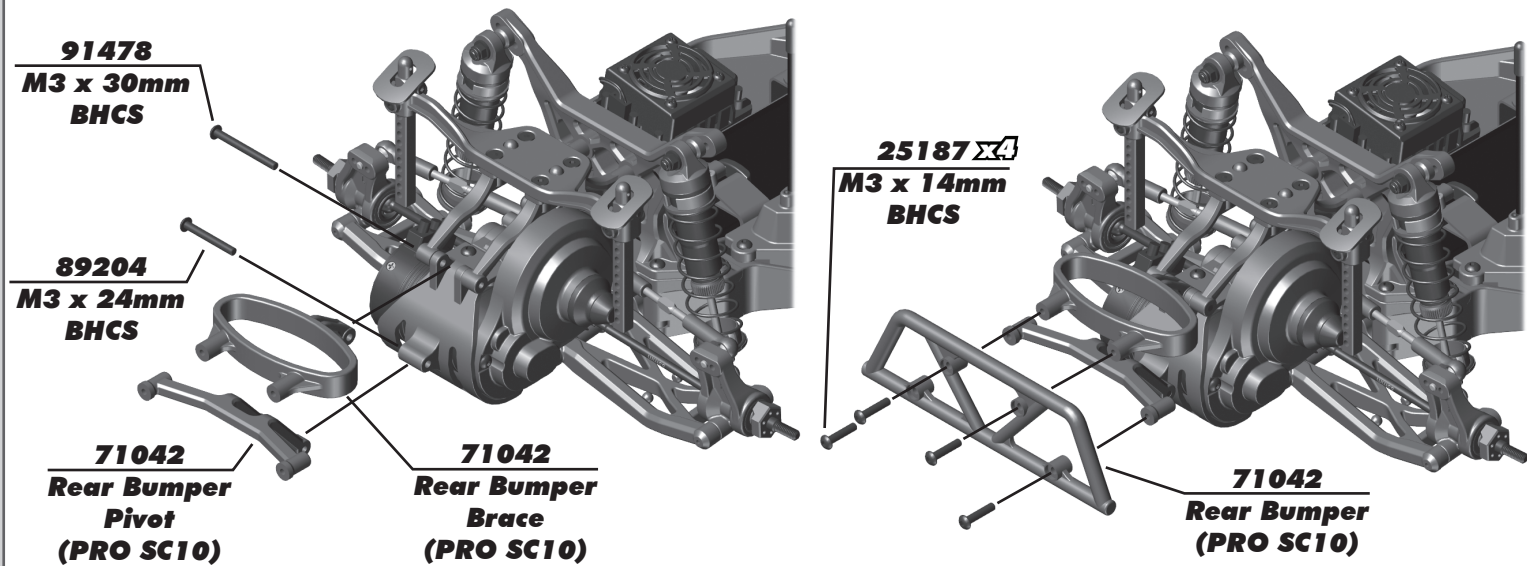

**:: Tires and Body Build - Step 1**

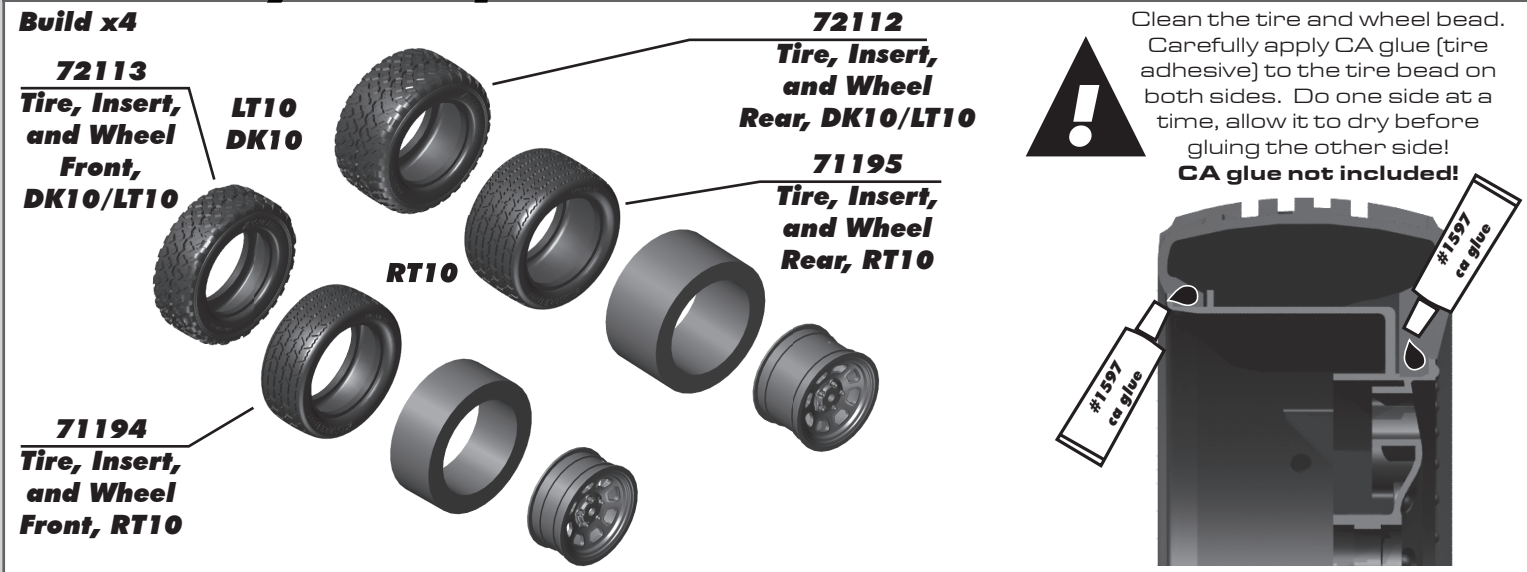

**:: Tires and Body Build - Step 2**

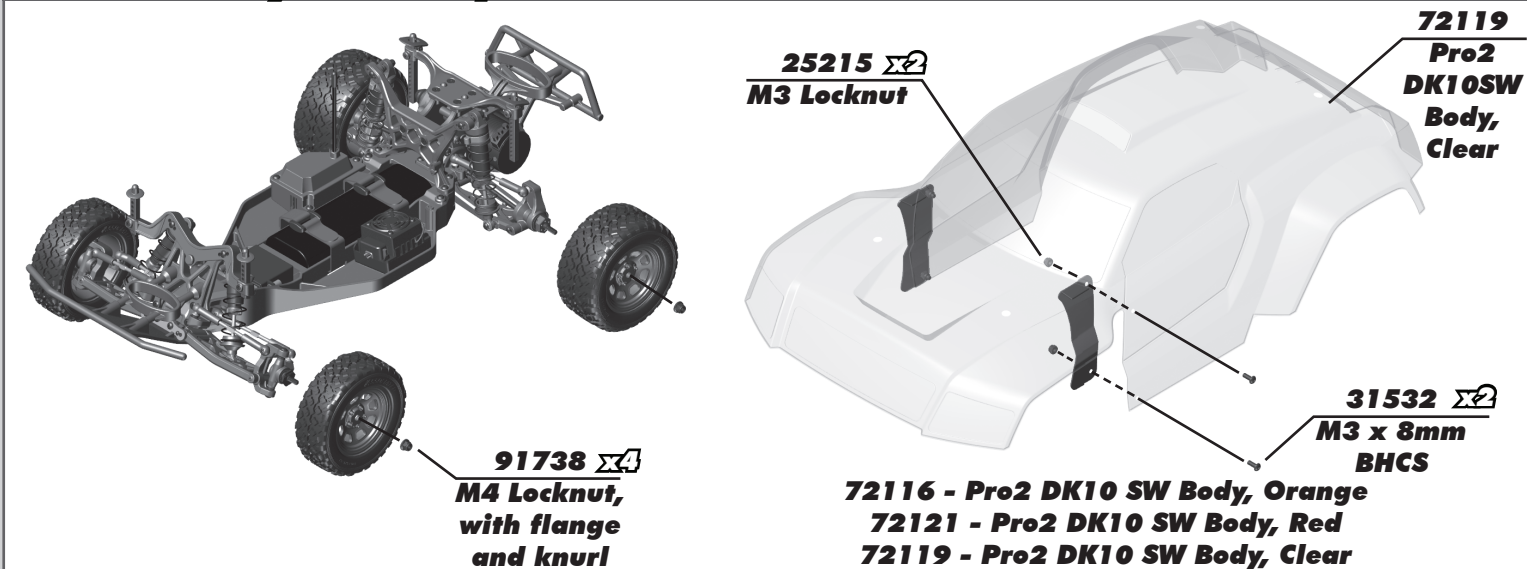

## :: Tires and Body Build - Step 3

**21173 x4**  
**Small**  
**Body Clips**

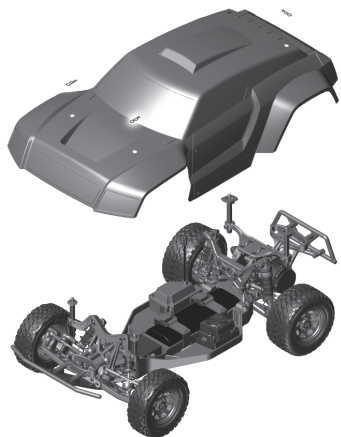

**21173 x4**  
**Small**  
**Body Clips**

**72118**  
**Pro2 LT10 SW**  
**Body, Clear**

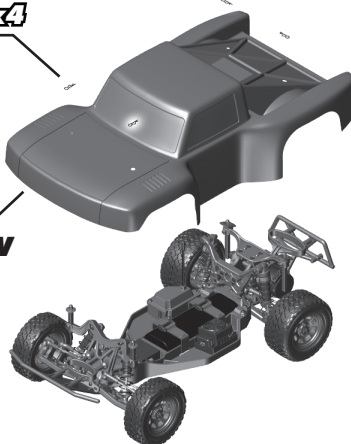

**21173 x4**  
**Small**  
**Body Clips**

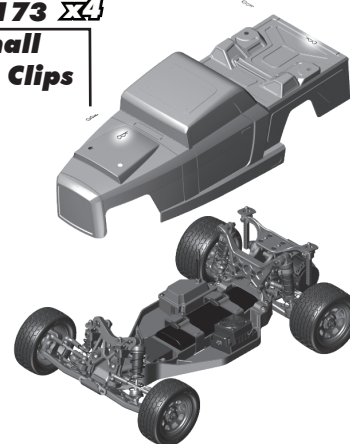

**72117 - Pro2 LT10 SW Body, White**  
**72120 - Pro2 LT10 SW Body, Green**  
**72118 - Pro2 LT10 SW Body, Clear**

**72122 - Pro2 RT10 SW Body, Black**

## :: Tuning Tips

### Tips for Beginners:

Before making any changes to the standard setup, make sure you can get around the track without crashing. Changes to your vehicle will not be beneficial if you can't stay on the track. Your goal is consistent laps.

Once you can get around the track consistently, start tuning your vehicle. Make only ONE adjustment at a time, testing it before making another change. If the result of your adjustment is a faster lap, mark the change on the included setup sheet (make additional copies of the sheet before writing on it). If your adjustment results in a slower lap, revert back to the previous setup and try another change.

When you are satisfied with your vehicle, fill in the setup sheet thoroughly and file it away. Use this as a guide for future track days or conditions. Periodically check all moving suspension parts. Suspension components must be kept clean and move freely without binding to prevent poor and/or inconsistent handling.

### Motor Gearing:

Proper motor gearing will result in maximum performance and run time while reducing the chance of overheating and premature motor failure. The gear ratio chart lists recommended **starting gear ratios** for the most widely used motor types. Gear ratios will vary depending upon motor brand, wind, and electronic speed control. Consult your motor and electronic speed control manufacturers for more information. Team Associated is not responsible for motor damage due to improper gearing.

#### **Gear Ratio Chart (Internal Gear Ratio 2.60:1)**

<b>Motor</b>	<b>Pinion</b>	<b>Spur</b>	<b>Final Drive Ratio</b>
17.5 Reedy Sonic Brushless	*28	*75	6.96:1
13.5 Reedy Sonic Brushless	*26	*75	7.50:1
10.5 Reedy Sonic Brushless	*24	87	9.42:1
3300kV Brushless	18	87	12.57:1

**\* Optional spur gear / pinion used**

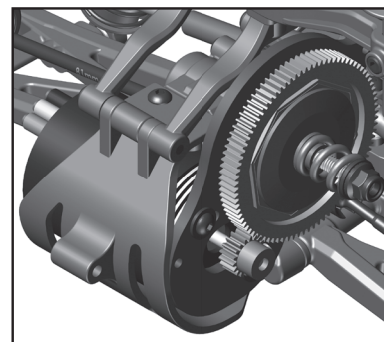

### Set The Gear Mesh:

You should be able to rock the spur gear back and forth in the teeth of the pinion gear without making the pinion gear move. If the spur gear mesh is tight, then loosen the #31532 screws and move the motor away, then try again. A gear mesh that is too tight or too loose will reduce power and damage the gear teeth.

# FIND IT ON ASSOCIATEDELECTRICS.COM

## CARS & TRUCKS



### Vehicle Spare Parts

GO TO:

[AssociatedElectrics.com](#) →  
[Team Associated tab](#) →  
[Cars & Trucks](#) →  
[Scroll to your vehicle](#) →  
[Parts & Accessories link](#)

## SETUP SHEETS & MANUALS



### Setups and Manuals

GO TO:

[AssociatedElectrics.com](#) →  
[Team Associated tab](#) →  
[Manuals & Setups](#) →  
[Scroll to your vehicle](#)

## A-TEAM APPS



### Tuning Guides & Tips

GO TO:

[AssociatedElectrics.com](#) →  
[Support](#) →  
[A-Team Apps](#)



**Associated Electrics, Inc.**

**21062 Bake Parkway Lake Forest, CA 92630 USA**

**call: (949) 544-7500 - fax: (949) 544-7501**

**Check out the following web sites for all of our kits, current products,  
new releases, setup help, tips, and racing info!**

**[www.AssociatedElectrics.com](http://www.AssociatedElectrics.com)**

**FOLLOW US ON SOCIAL MEDIA**



**TeamAssociated**  
**ReedyPower**  
**ElementRC**

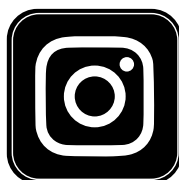

**@TeamAssociatedRC**  
**@ReedyPower**  
**@Element\_RC**



**@Team\_Associated**  
**@ReedyPower**