

Revell Kit 15093 Millennium Falcon TM

Paint Guide Revell Inc.	Revell GmbH Colors	
	Farb-Nummer Color Code	Farbbezeichnung / Color Name GB D
A Black	302	Black silk matt Schwarz seidenmatt
B Burnt Iron	91	Steel metallic Eisen metallic
C Dark Blue	56	Blue matt Blau matt
D Flat Black	6	Tar Black matt Teerschwarz matt
E Flesh	35	Flesh matt Hautfarbe matt
F Gold	94	Gold metallic Gold metallic
G Gray	371 (90%)+374 (10%)	Light Grey + Grey silk matt Hellgrau + Grau
H Khaki	86	Olive Brown matt Khakibraun matt
I Neutral Gray	371	Light grey silk matt Hellgrau seidenmatt
J Off White	5	White matt Weiß matt
K Red	331	Purple Red silk matt Purpurrot seidenmatt
L Red Brown	85	Brown matt Braun matt
M Rust	83	Rust matt Rost matt
N Sand Yellow	16	Sandy Yellow matt Sand matt
O Silver	90	Silver metallic Silber metallic
P Tan	89	Beige matt Beige matt
Q White	301	White silk matt Weiß seidenmatt
R Yellow	310(90%)+382(10%)	Lufthansa Yellow + Wood Brown silk matt Lufthansa-Gelb + Holzbraun seidenmatt

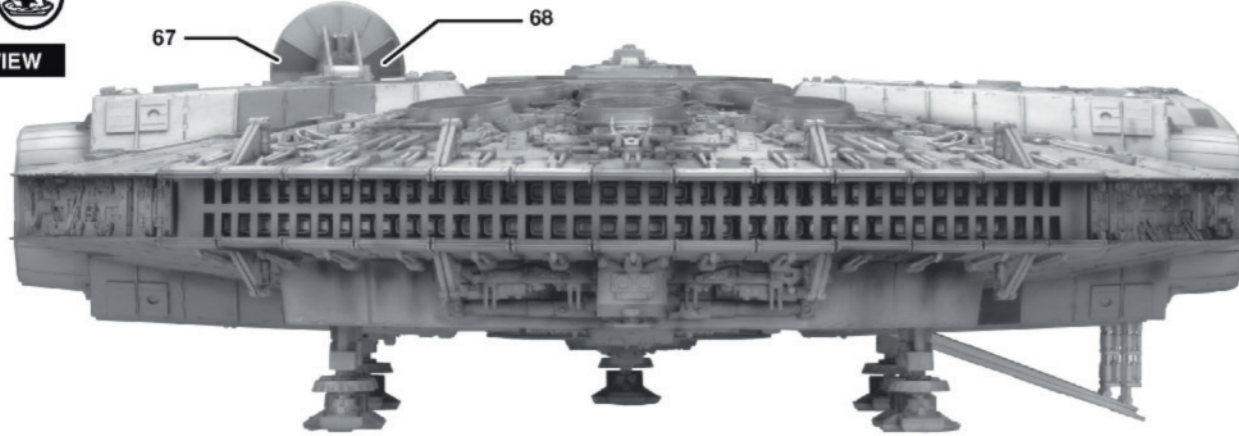

REAR VIEW



DETAILS

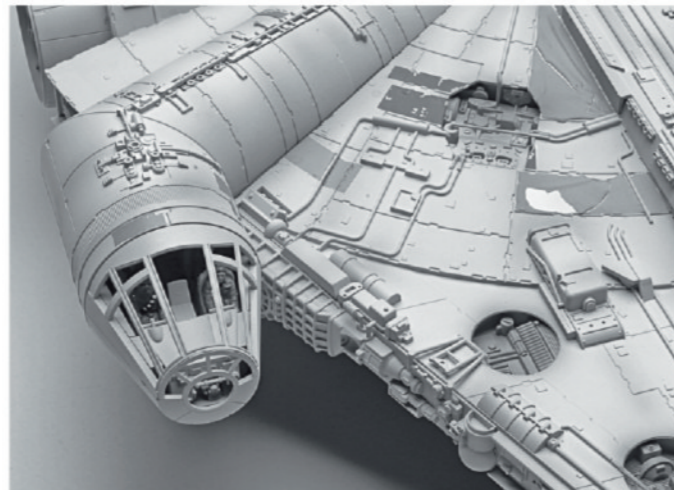
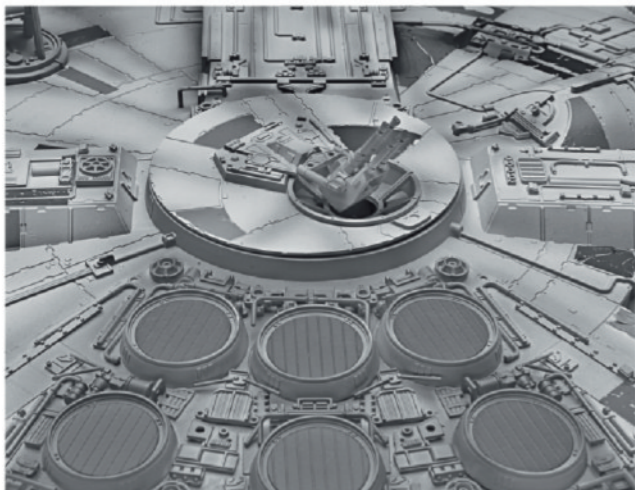
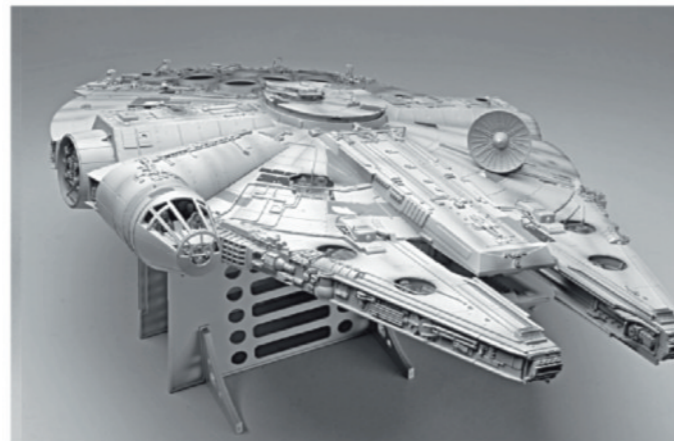
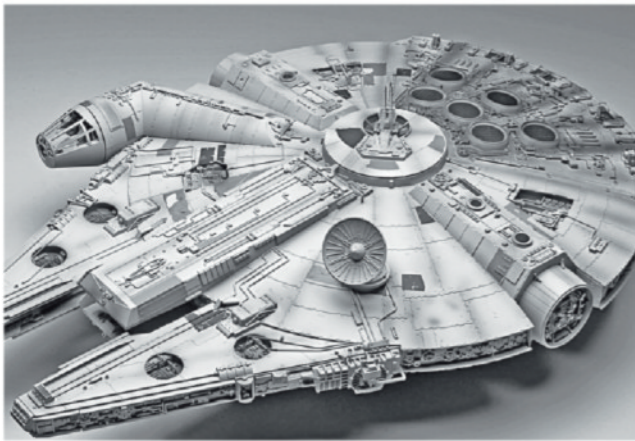

starwars.com

© & ™ Lucasfilm Ltd.

All trademarks used under license.
Toutes les marques de commerce utilisées sous licence.
Todos las marcas comerciales utilizadas conforme a licencia.

Revell

KIT 5093

85509300200

MILLENNIUM FALCON™

MASTER SERIES



The Millennium Falcon was made by the Corellian Engineering Corporation. It was originally a YT-1300 Light Freighter, but then it was subsequently modified by smugglers. At that time, it was known as the Stellar Envoy. Then after going through a few owners and being crashed, Han Solo won the Millennium Falcon from Lando Calrissian in a card game. For Solo and his Wookiee copilot, Chewbacca, it was the perfect ship for their smuggling exploits through the galaxy. However, it wasn't long before they got themselves involved in the battle of the Alliance to Restore the Republic. Getting into battle with the Empire would take all the resources of the Millennium Falcon, but Han Solo knew it was up to the job. It is heavily armed with two quad laser cannons, two disruptors and an up-to-date Imperial deflector system. It has a bank of sensors that can track distant Imperial ships long before they are seen. Finally, the Millennium Falcon is one of the fastest ships in the galaxy and can outrun any Imperial ship. With this kind of performance, Han figured the odds were with him.

Le faucon millénaire a été fabriqué par Corellian Engineering Corporation. Il s'agissait à l'origine d'un transporteur léger de type YT-1300, mais il a été modifié plus tard par des contrebandiers. À cette époque, il était connu sous le pseudo envoi stellaire. Après avoir passé dans les mains de plusieurs propriétaires et vécu plusieurs accidents, Han Solo a remporté le faucon millénaire aux cartes des mains de Lando Calrissian. Pour Solo et son copilote Wookiee, Chewbacca, c'est le vaisseau parfait pour leurs exploits de contrebande au sein de la galaxie. Cela n'aura cependant pas pris beaucoup de temps avant qu'ils se voient impliqués dans la bataille de l'Alliance pour restaurer la République. Se rendre à la bataille contre l'Empire nécessiterait toutes les ressources du faucon millénaire, mais Han Solo savait que c'était faisable. Il est lourdement armé de deux canons laser quad, deux désintégrateurs et un système de déflecteur impérial des plus évolués. Il comporte une banque de détecteurs capables de détecter les vaisseaux impériaux bien avant d'être vu. Finalement, le faucon millénaire est un des vaisseaux les plus rapides de la galaxie et il peut surpasser en vitesse tous les vaisseaux impériaux. En raison de ce type de performance, Han en a conclu que les chances étaient de son bord.

La Millennium Falcon fue fabricada por la Corellian Engineering Corporation. Originalmente era un carguero ligero YT-1300, pero posteriormente fue modificada por los contrabandistas. En ese momento, se le conocía como el Stellar Envoy (Enviado Estelar). Luego, después de pasar por unos cuantos propietarios y estrellarse, Han Solo le ganó a Millennium Falcon a Lando Calrissian, en un juego de cartas. Para Solo y su copiloto Wookiee, Chewbacca, era la nave perfecta para sus hazañas de contrabando a través de la galaxia. Sin embargo, no pasó mucho tiempo antes de que se vieran envueltos en la batalla de la Alianza para restaurar la República. Entrar en batalla con el Imperio tomaría todos los recursos del Millennium Falcon, pero Han Solo sabía que estaba a la altura. Fuertemente armado con dos cañones láser cuádruples, dos disruptores y un sistema deflector Imperial actualizado. Cuenta con un banco de sensores que pueden realizar un seguimiento a distancia de naves imperiales antes de que lo vean. Por último, la Millennium Falcon es una de las naves más rápidas en la galaxia y puede superar cualquier otra nave imperial. Con este tipo de desempeño, Han calculó que las probabilidades estaban con él.

READ THIS BEFORE YOU BEGIN

- * Study the assembly drawings.
- * Each plastic part is identified by a number.
- * In the assembly drawings, some parts will be marked by a star ★ to indicate chrome plated plastic.
- * For better paint and decal adhesion, wash the plastic parts in a mild detergent solution. Rinse and let air dry.
- * Check the fit of each piece before cementing in place.
- * Use only cement for polystyrene plastic.
- * Scrape plating and paint from areas to be cemented.
- * Allow paint to dry thoroughly before handling parts.
- * Any unused parts may be discarded.

CUSTOMER SERVICE

If you have questions, comments or problems visit our website revell.com or write to us at:

Revell Inc. Consumer Service
1850 Howard St. Unit A
Elk Grove Village, IL 60007

Be sure to include this plan number (85509300200), part number, description and your return address and phone number.

LISEZ CECI AVANT DE COMMENCER

- * Étudiez les plans d'assemblage.
- * Chaque pièce de plastique est identifiée par un numéro.
- * Dans les plans d'assemblage, certaines pièces seront marquées d'une étoile ★ pour indiquer des pièces en plastique plaquées chrome.
- * Pour une meilleure adhésion de la peinture et de la décalcomanie, lavez les pièces en plastique dans une solution de détergent doux. Rincez et laissez sécher à l'air.
- * Vérifiez l'ajustement de chaque pièce avant de la coller en place.
- * Utilisez uniquement de la colle pour plastique au polystyrène.
- * Grattez toute peinture et le placage sur les régions à coller.
- * Laissez sécher la peinture complètement avant de manipuler des pièces.
- * Toute pièce non-utilisée peut être jetée.

SERVICE À LA CLIENTÈLE

Pour toute question, problème ou commentaire, visitez-nous à l'adresse revell.com ou écrivez-nous à :

Revell Inc. Consumer Service
1850 Howard St. Unit A
Elk Grove Village, IL 60007

Assurez-vous d'inclure ce numéro de plan (85509300200), le numéro de pièce, une description ainsi que votre adresse de retour et numéro de téléphone.

LEA ESTO ANTES DE EMPEZAR

- * Estudie los dibujos de ensamblaje.
- * Cada parte plástica está identificada con un número.
- * En los dibujos de ensamblaje, algunas partes aparecerán marcadas con una estrella ★ para indicar plástico enchapado en cromo.
- * Para mejor adhesión de pintura y calcomanías, lave las partes plásticas en una solución de detergente suave. Enjuague y deje secar al aire.
- * Verifique el encastrado de cada pieza antes de cementar en su lugar.
- * Use sólo cemento para plástico de poliestireno.
- * Raspe las placas y la pintura de las áreas a cementar.
- * Deje secar la pintura totalmente antes de manipular las partes.
- * Cualesquiera partes sin usar se pueden descartar.

SERVICIO AL CLIENTE

Si tiene preguntas, comentarios o problemas, visite nuestro sitio web revell.com o escribanos a:

Revell Inc. Consumer Service
1850 Howard St. Unit A
Elk Grove Village, IL 60007

Asegúrese de incluir el número de plano (85509300200), el número de parte, la descripción y su dirección y número de teléfono para responder.

PAINT GUIDE		GUIDE DE PEINTURE		GUÍA DE PINTURA	
This paint guide is provided to complete this kit as shown on the box.		Ce guide de peinture est fourni pour compléter cet ensemble tel qu'indiqué sur l'emballage.		Esta guía de pintura se suministra para completar este equipo tal como se muestra en la caja.	
A	Black	Noir	Negro		
B	Burnt Iron	Fer brûlé	Hierro quemado		
C	Dark Blue	Bleu foncé	Azul oscuro		
D	Flat Black	Noir mat	Negro mate		
E	Flesh	Chair	Carne		
F	Gold	Or	Oro		
G	Gray	Gris	Gris		
H	Khaki	Kaki	Caqui		
I	Neutral Gray	Gris neutre	Gris neutro		
J	Off White	Blanc cassé	Blanco hueso		
K	Red	Rouge	Rojo		
L	Red Brown	Brun rouge	Marrón rojizo		
M	Rust	Rouille	óxido		
N	Sand Yellow	Jaune sablé	Amarillo arena		
O	Silver	Argent	Plata		
P	Tan	Havane	Havane		
Q	White	Blanc	Blanco		
R	Yellow	Jaune	Amarillo		

- DECAL APPLICATION INSTRUCTIONS**
1. Cut desired decal from sheet.
 2. Dip decal in water for a few seconds.
 3. Place wet decal on paper towel.
 4. Wait until decal is movable on paper backing.
 5. Place decal in position on model, face up and slide backing away.
 6. Press out air bubbles with a soft damp cloth.
 7. Milkiness that may appear is for better decal adhesion and will dry clear. Wipe away any excess adhesive.
 8. Do not touch decal until fully dry.
 9. Allow the decals 48 hours to dry before applying clear coat.
 10. Decals are compatible with setting solutions or solvents.

- INSTRUCTIONS POUR L'APPLICATION DE DÉCALCOMANIE**
1. Découpez la décalcomanie désirée sur la feuille.
 2. Trempez la décalcomanie durant quelques secondes dans l'eau.
 3. Placez la décalcomanie sur une serviette de papier.
 4. Attendez jusqu'à ce que la décalcomanie puisse être retirée de l'endos en papier.
 5. Placez la décalcomanie en position sur votre modèle, face vers le haut, et retirez l'endos.
 6. Pressez pour évacuer les bulles d'air avec un chiffon doux humide.
 7. La formation d'un voile blanchâtre qui pourrait apparaître sert à la meilleure adhésion de la décalcomanie et deviendra claire une fois séchée. Nettoyez tout excès d'adhésif.
 8. Ne touchez pas la décalcomanie tant qu'elle ne sera pas entièrement séchée.
 9. Laissez sécher la décalcomanie durant 48 heures avant d'appliquer un enduit protecteur.
 10. Les décalcomanies sont compatibles avec les solutions de séchage et les solvants.

- INSTRUCCIONES DE APLICACIÓN DE CALCOMANÍAS**
1. Corte la calcomanía deseada de la lámina.
 2. Sumerja la calcomanía en agua por unos segundos.
 3. Coloque la calcomanía húmeda sobre una toalla de papel.
 4. Espere hasta que la calcomanía se mueva en la lámina posterior de papel.
 5. Coloque la calcomanía en posición sobre el modelo, con la cara hacia arriba y deslice la lámina posterior hasta quitarlo.
 6. Presione para quitar las burbujas de aire con un trapo suave húmedo.
 7. La lechosisidad que puede aparecer es para una mejor adhesión de la calcomanía y se secará completamente. Limpie cualquier exceso de adhesivo.
 8. No toque la calcomanía hasta que esté totalmente seca.
 9. Deje secar las calcomanías 48 horas antes de aplicar "clear coat".
 10. Las calcomanías son compatibles con las soluciones de fijación o los solventes.

* REPEAT SEVERAL TIMES * A RÉPÉTEZ PLUSIEURS FOIS * REPITA VARIAS VECES	* REPEAT PROCEDURE * RÉPÉTEZ LA PROCÉDURE * REPITA EL PROCEDIMIENTO	* OPTIONAL PARTS * PIÈCES OPTIONNELLES * PARTES OPCIONALES	* DECAL * DÉCALCOMANIE * CALCOMANÍA	* ASSEMBLY CAUTION * AVERTISSEMENT POUR L'ASSEMBLAGE * PRECAUCIÓN DE ENSAMBLAJE	* CEMENT TOGETHER * COLLER ENSEMBLE * CEMENTAR Y UNIR	* REMOVE AND THROW AWAY * RETIREZ ET JETER * RETIRE Y DESCARTE	* DO NOT CEMENT * NE PAS COLLER * NO CEMENTAR
* OPEN HOLE * LAISSEZ SÉCHER LES PIÈCES * ABRA AGUJERO	* REMOVE TAPE * RUBAN AMOVIBLE * CINTA DEMONTABLE	* RUBBER BAND TOGETHER * SERRER ENSEMBLE AVEC UNE BANDE ÉLASTIQUE * UNA CON BANDA ELÁSTICA	* STICKER DECAL * DÉCALCOMANIE AUTOCOLLANTE * CALCOMANÍA AUTOADHESIVA	* WEIGHT * POIDS * PESO	* TRIM OFF * DÉCOUPEZ * RECORTE	* HEATED SCREWDRIVER END * POINTE CHAUFFÉE DE TOURNEVIS * EXTREMO DE DESTORNILLADOR CALENTADO	

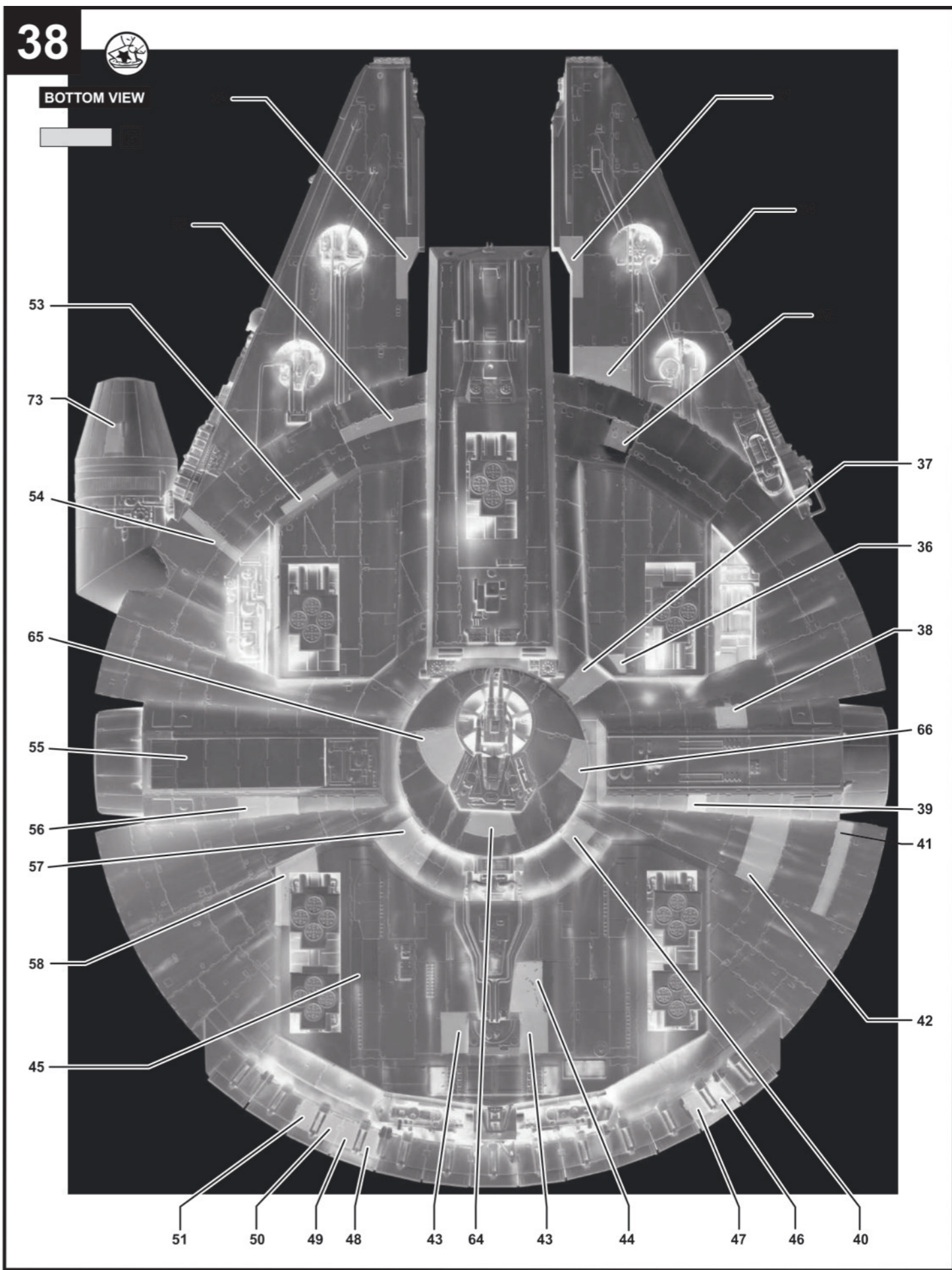



TOP VIEW

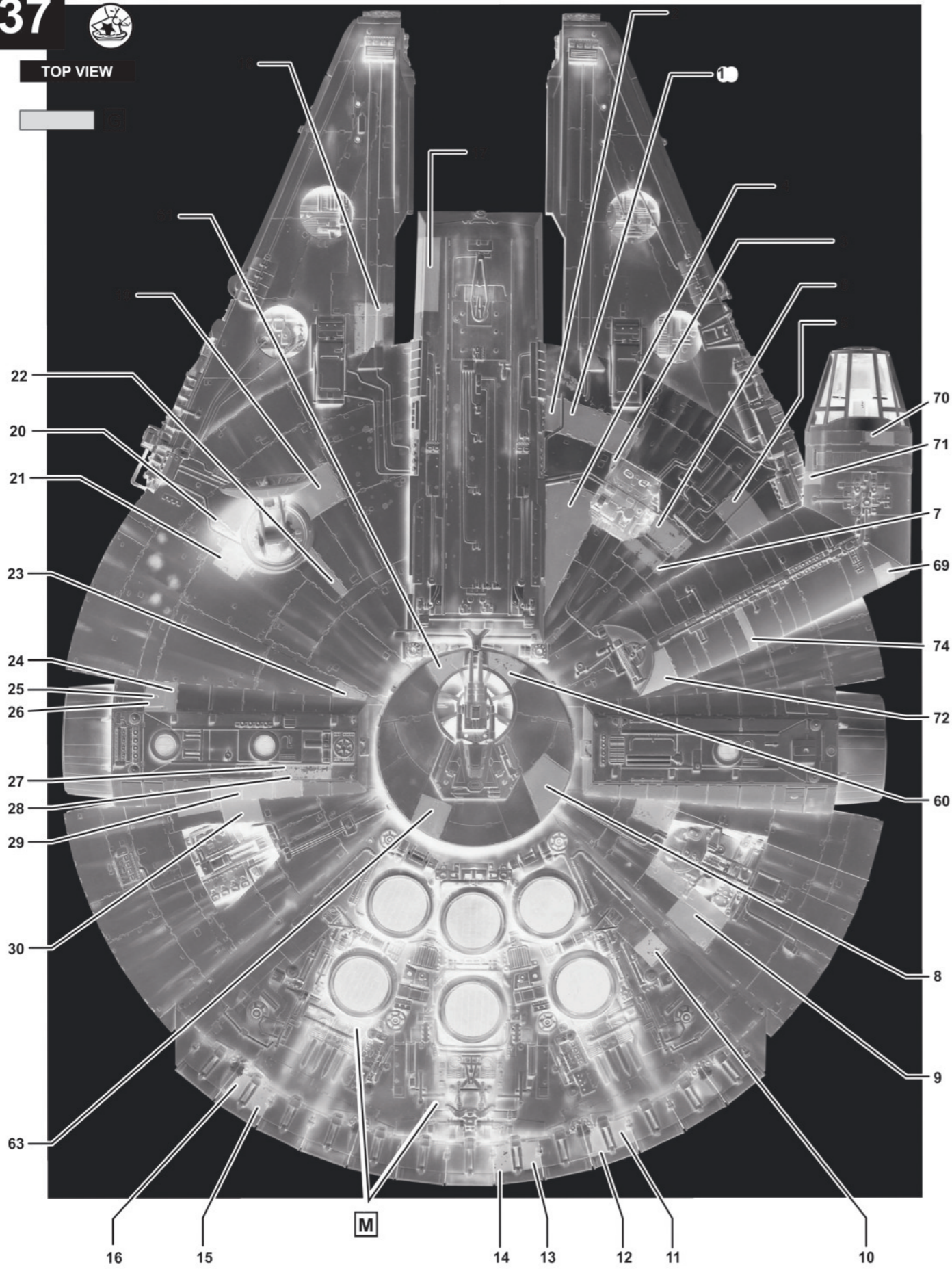

1

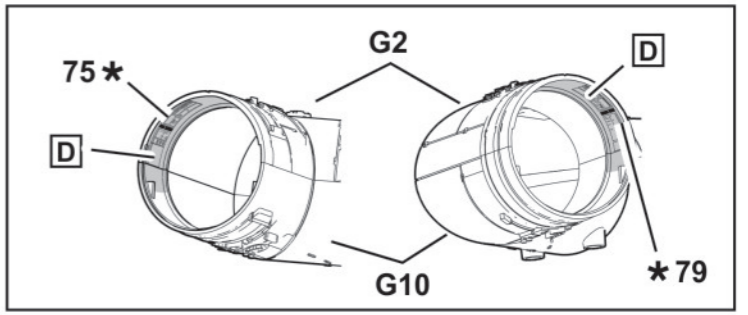
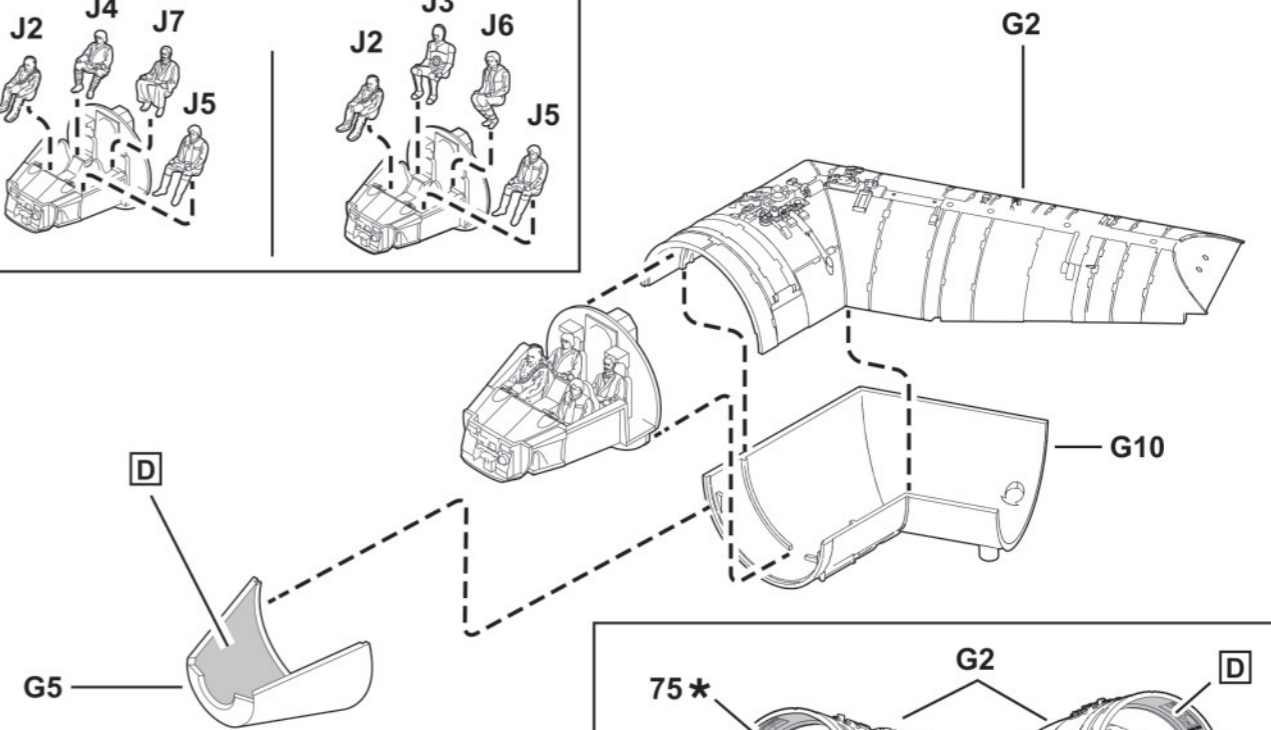
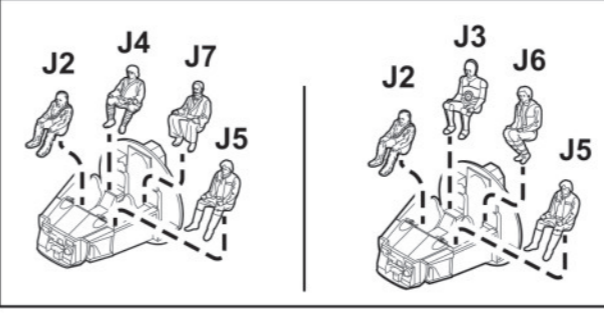
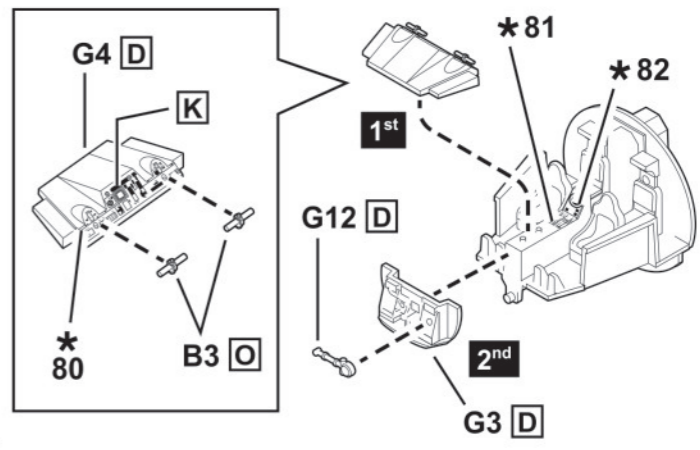
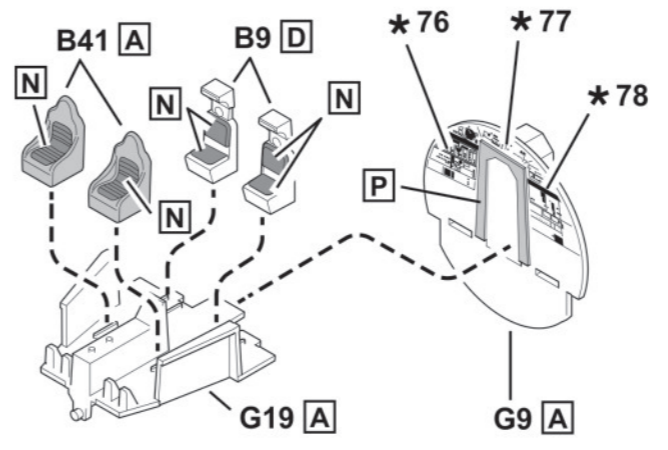
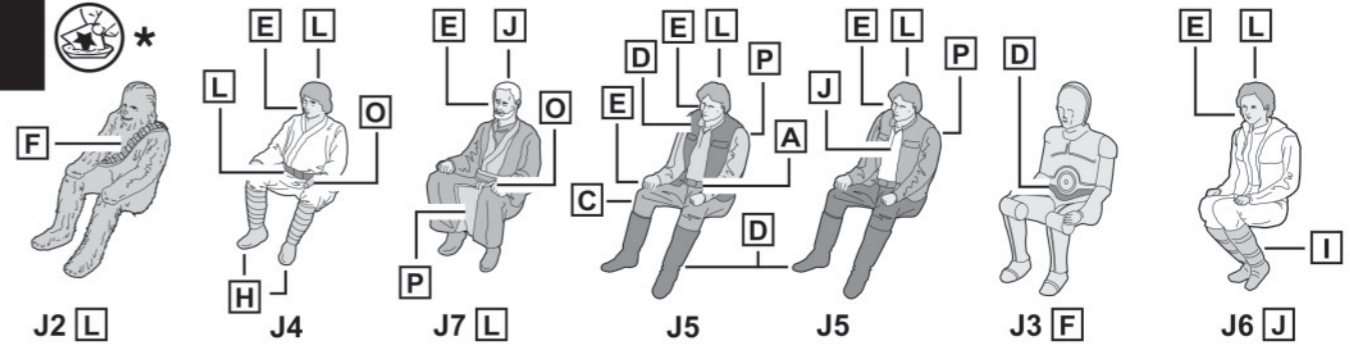

2

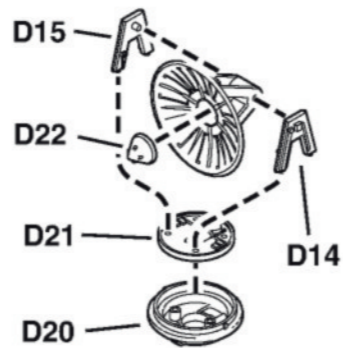
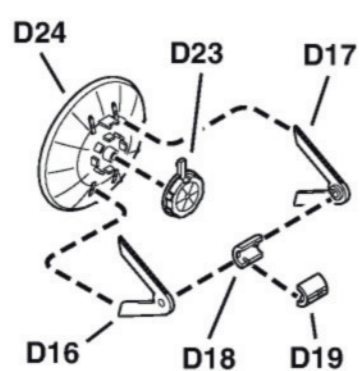
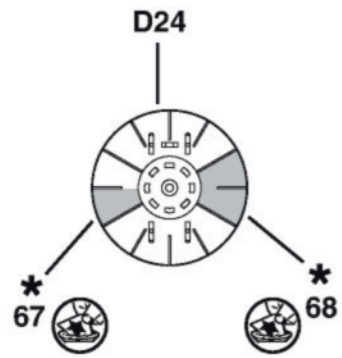
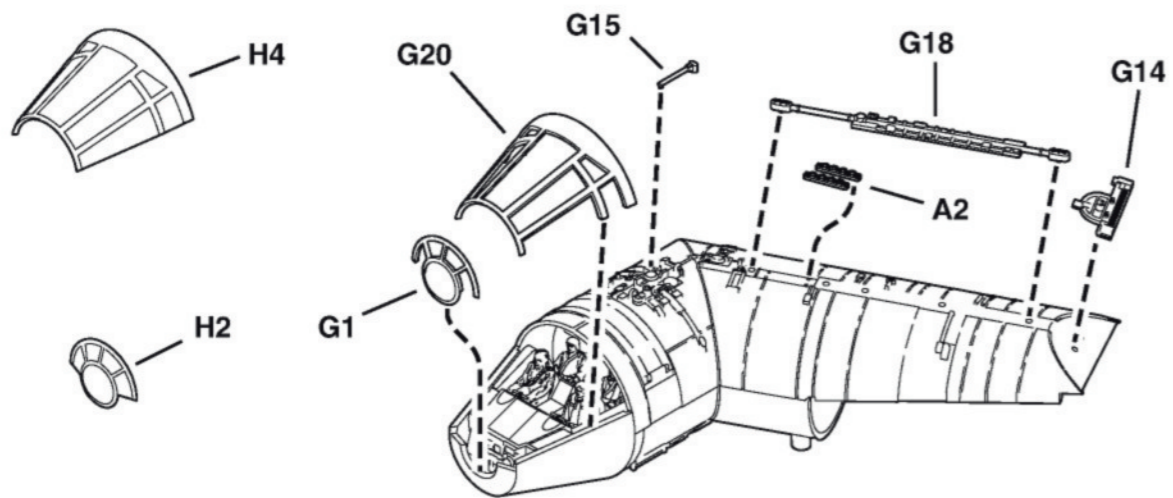

A

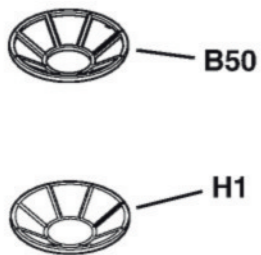

2nd

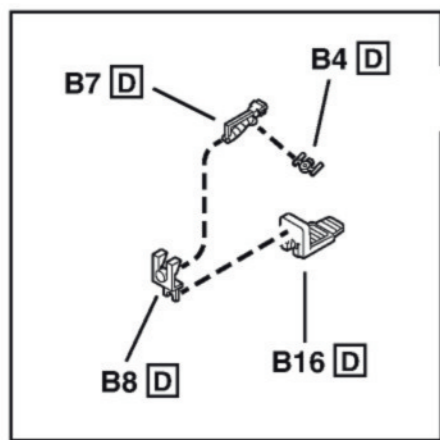
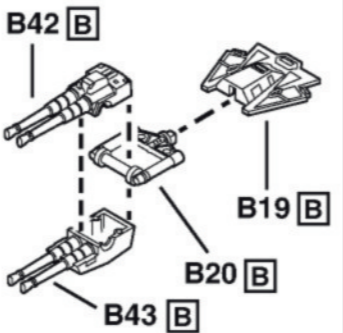

1st

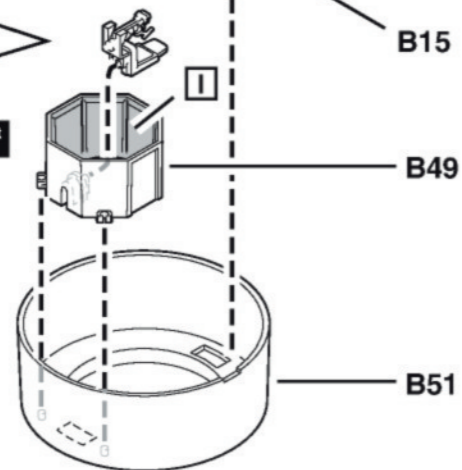

36

UPPER HULL

2

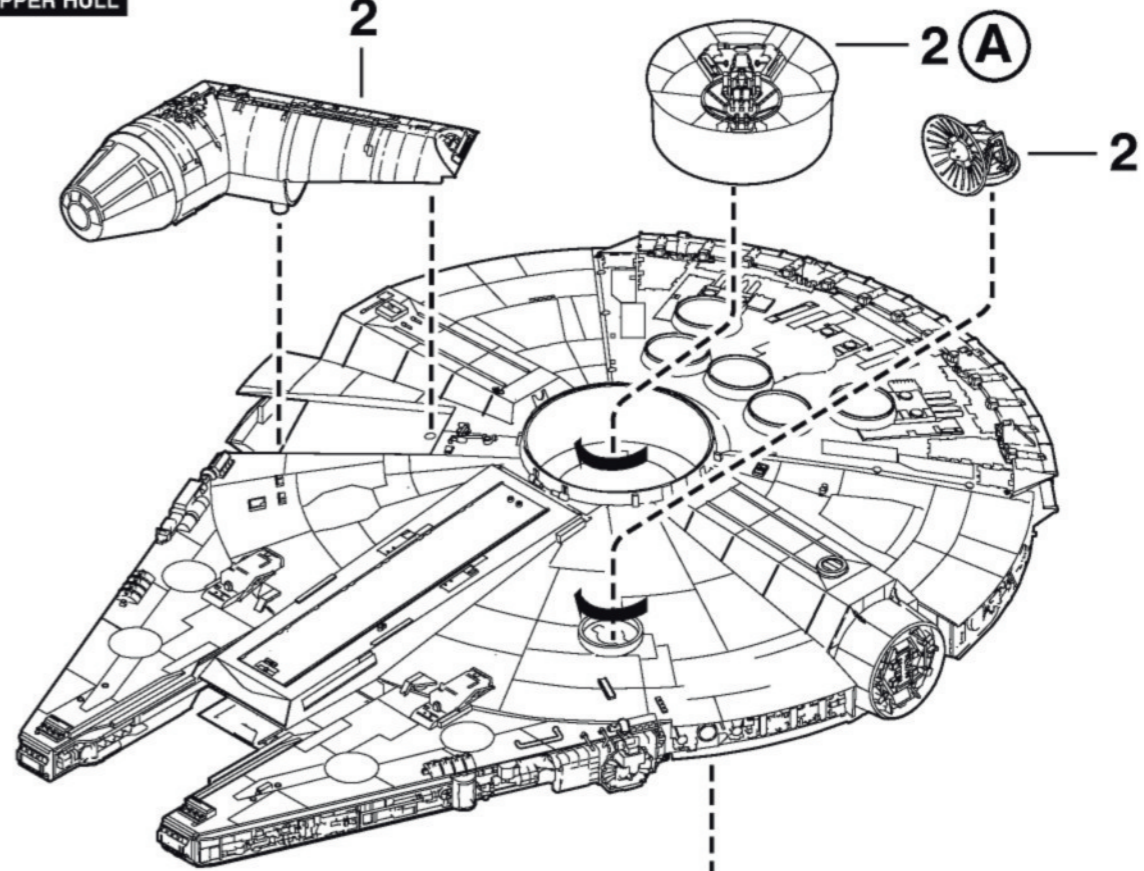

35(A)

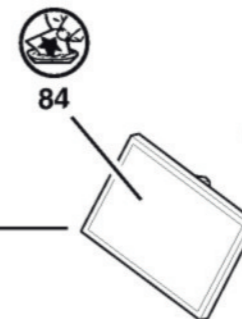

35(B)

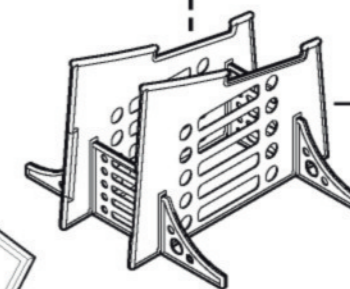

?

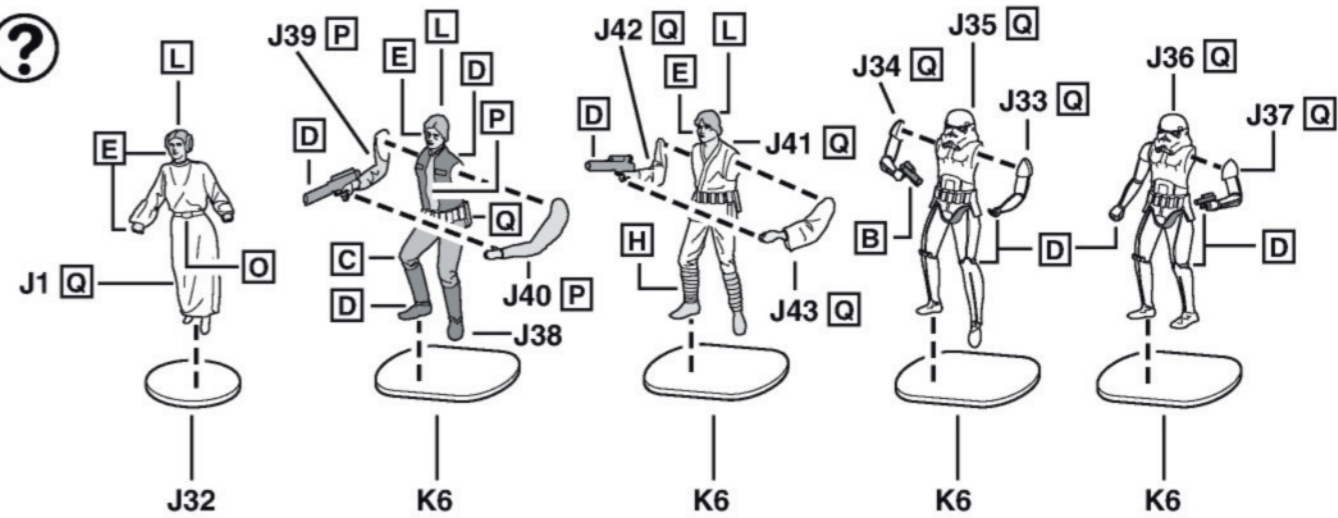

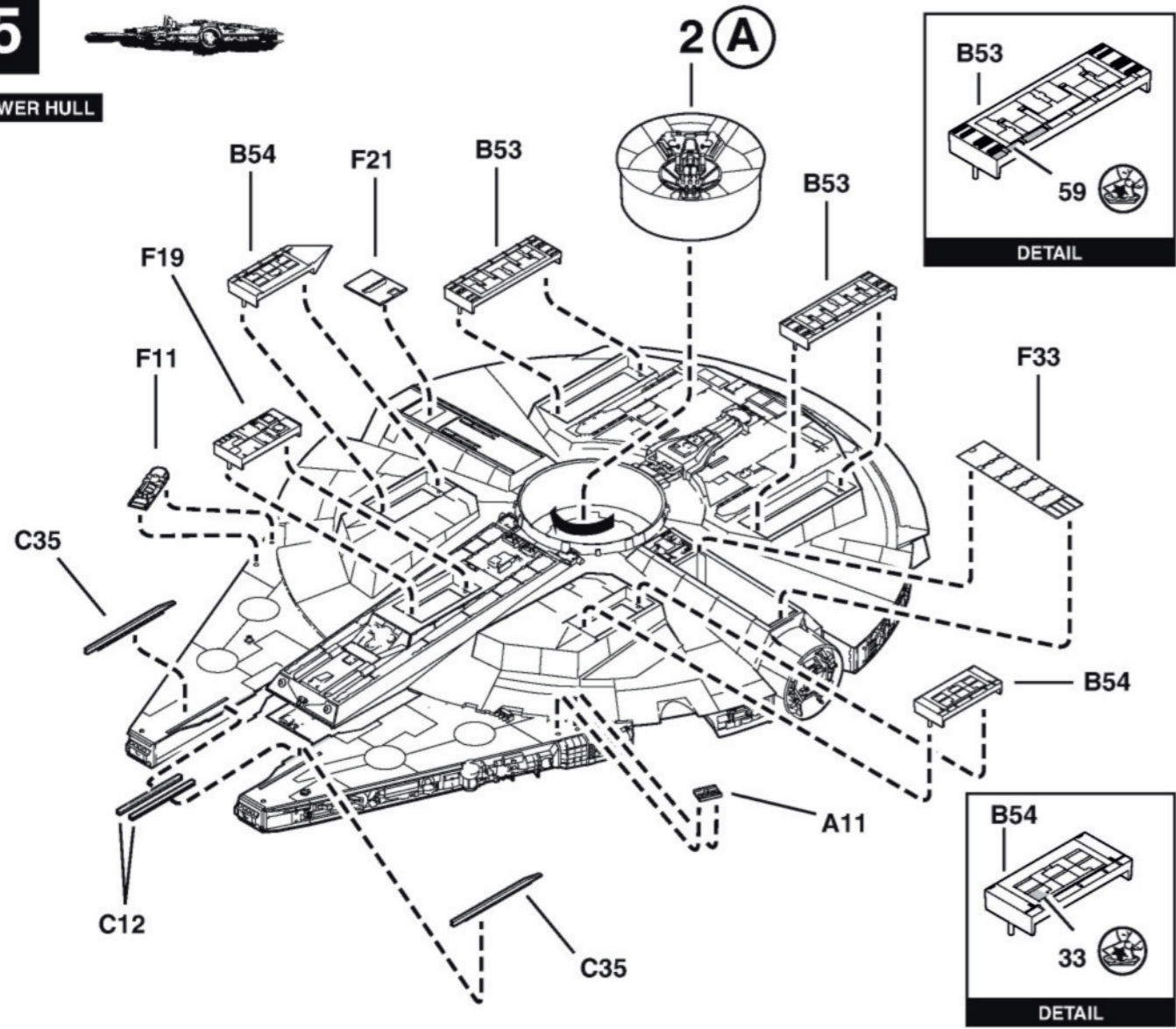

(A)

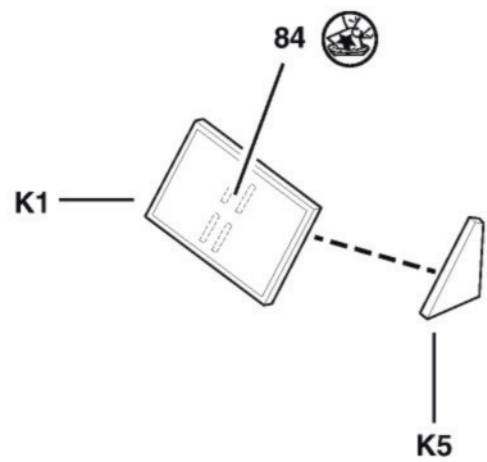

(B)

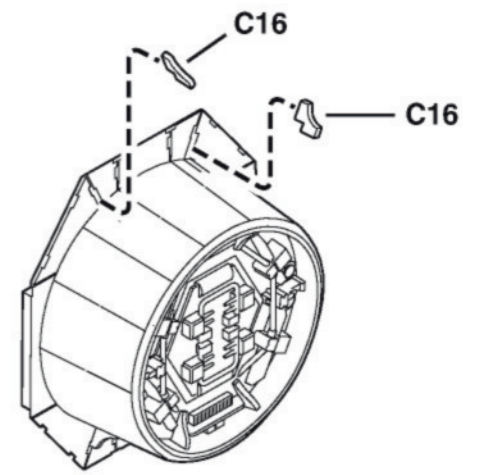
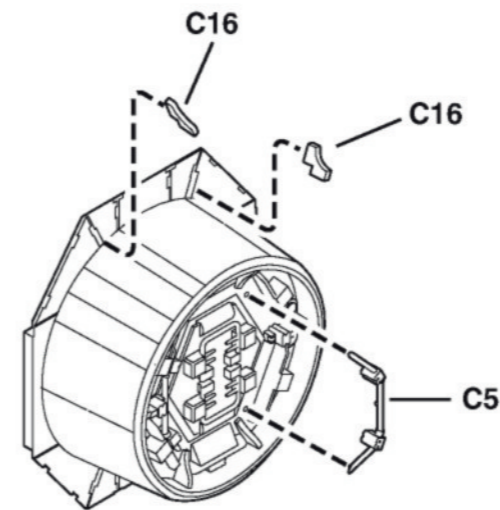
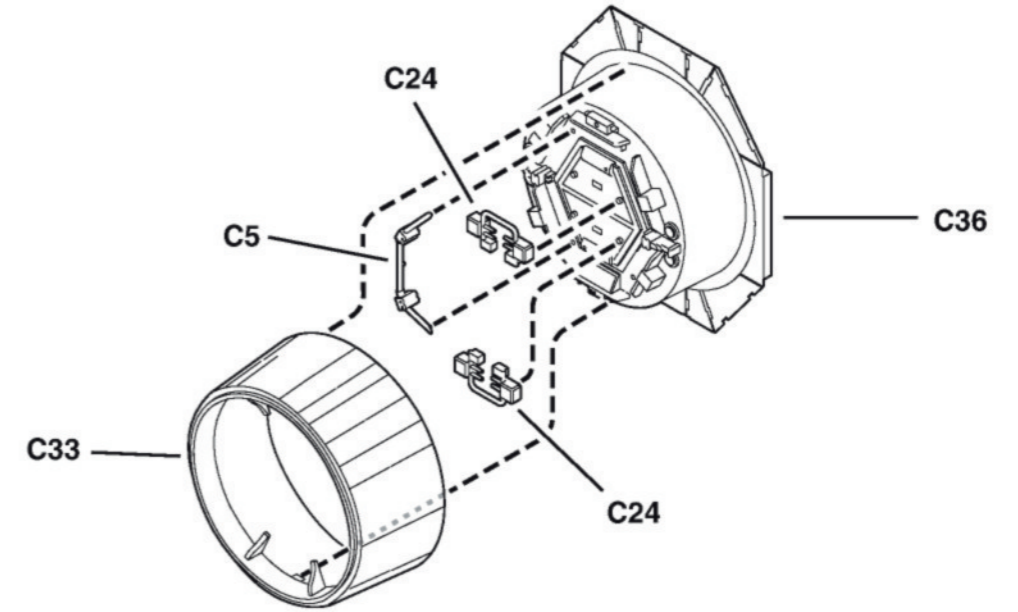
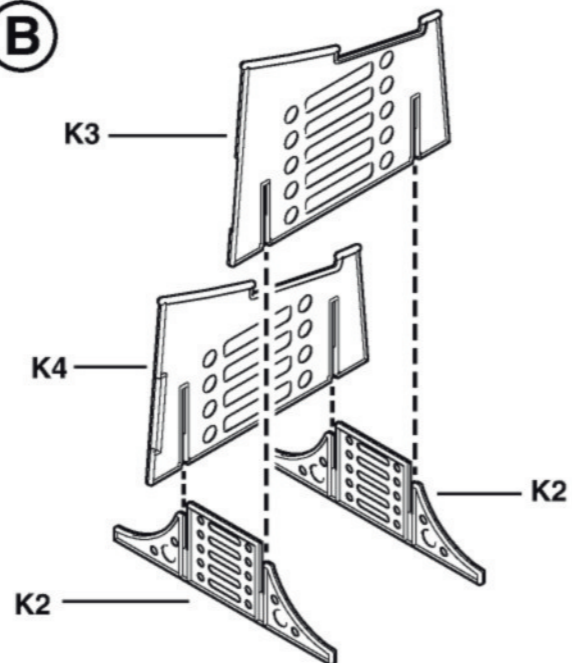

OTHER SIDE

LEFT

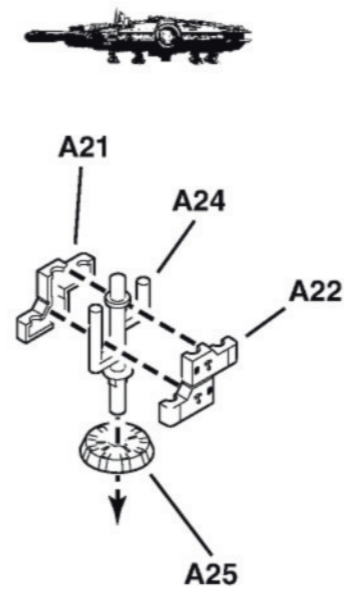

RIGHT

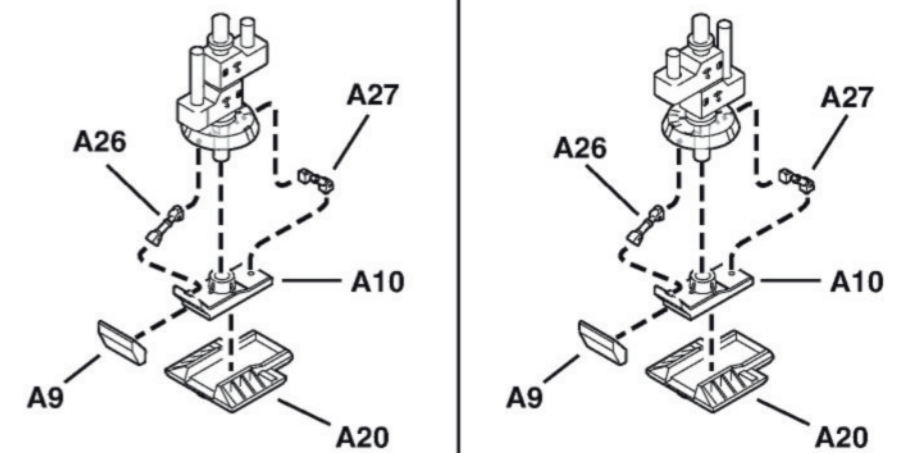

4

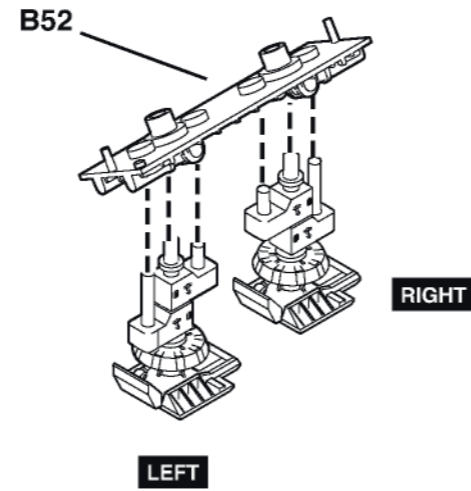
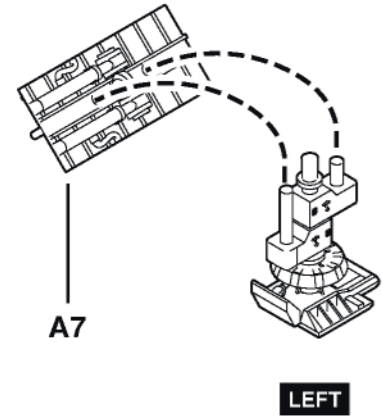

UPPER HULL

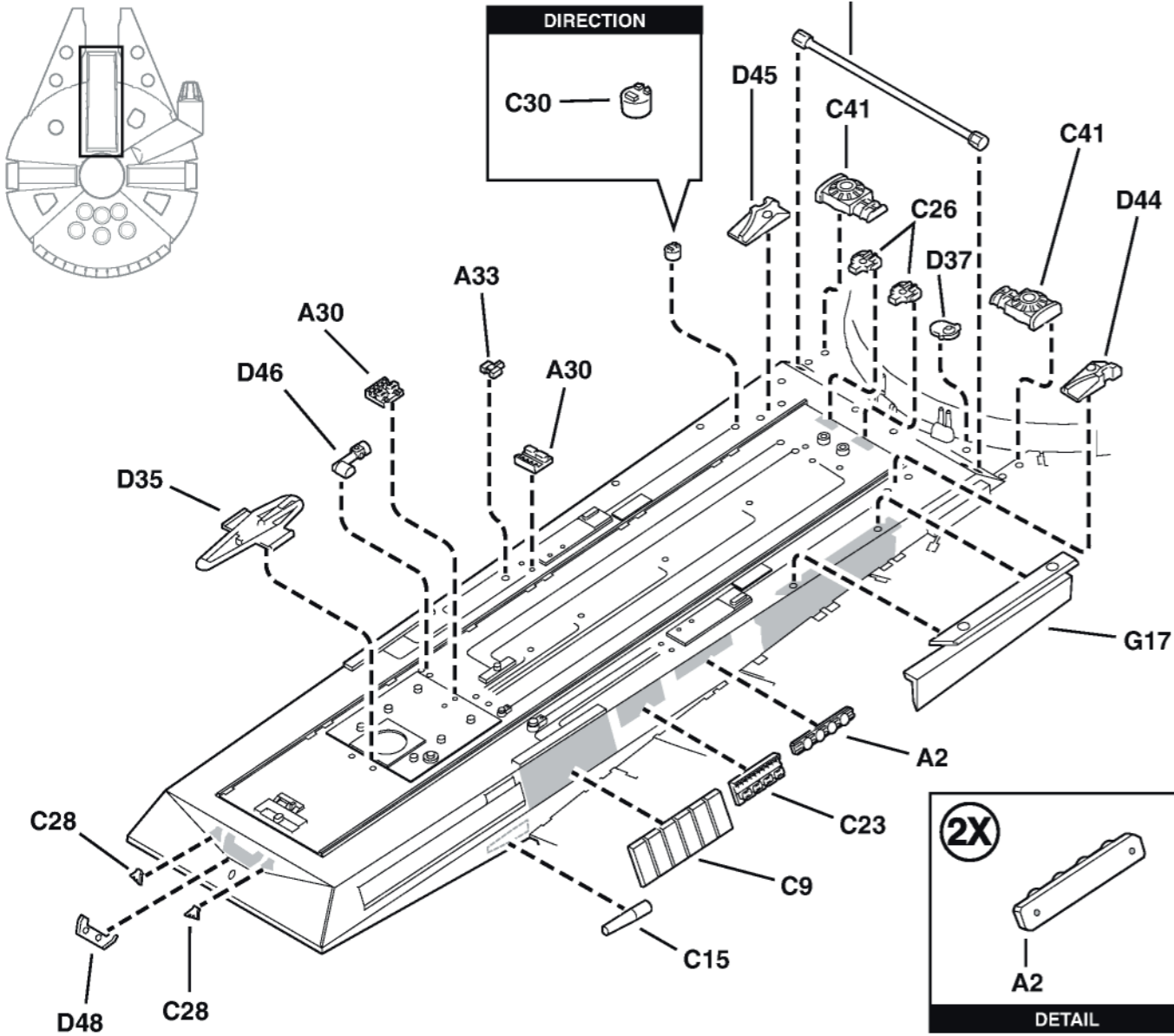

34



LOWER HULL

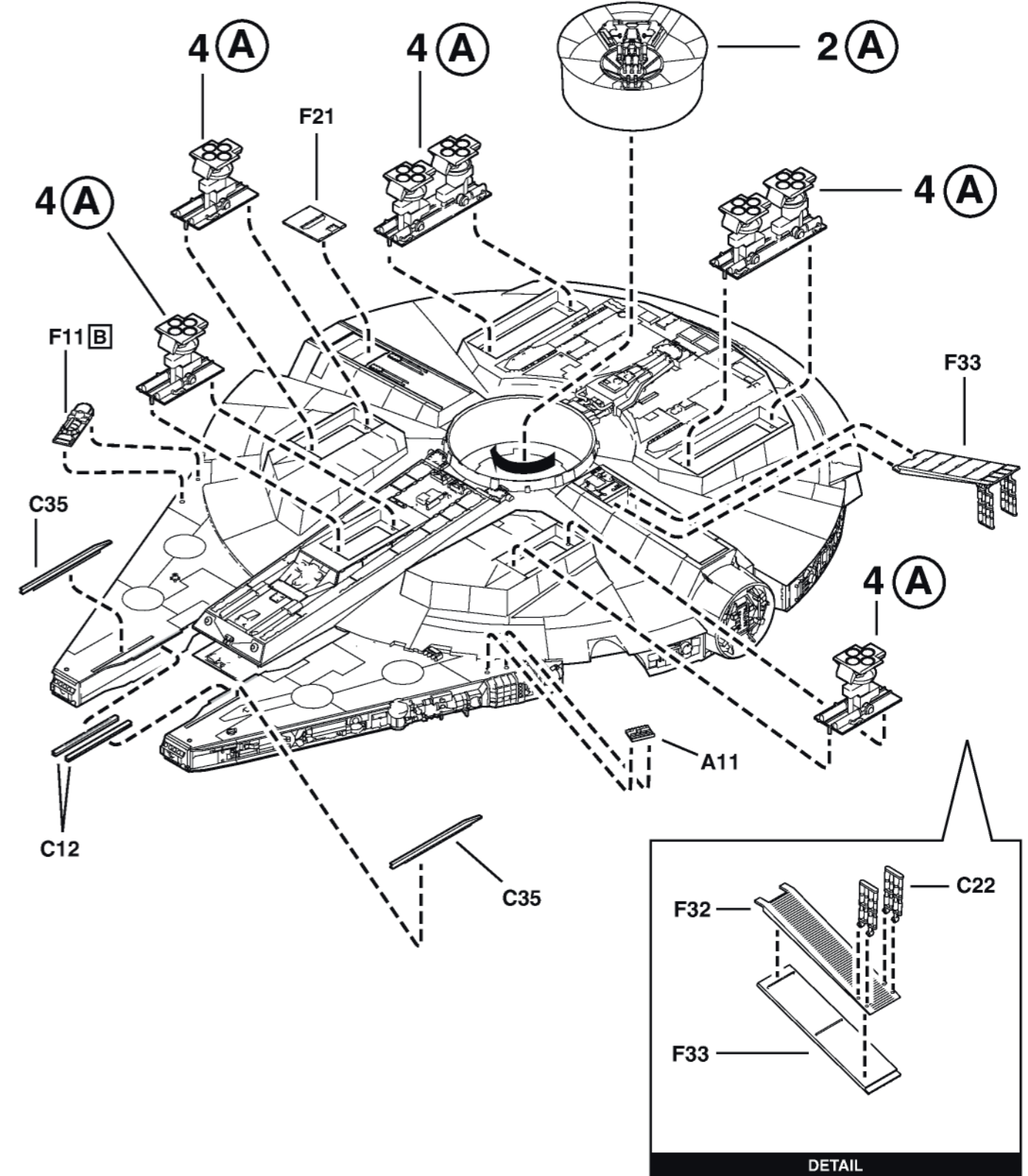

33

LEFT

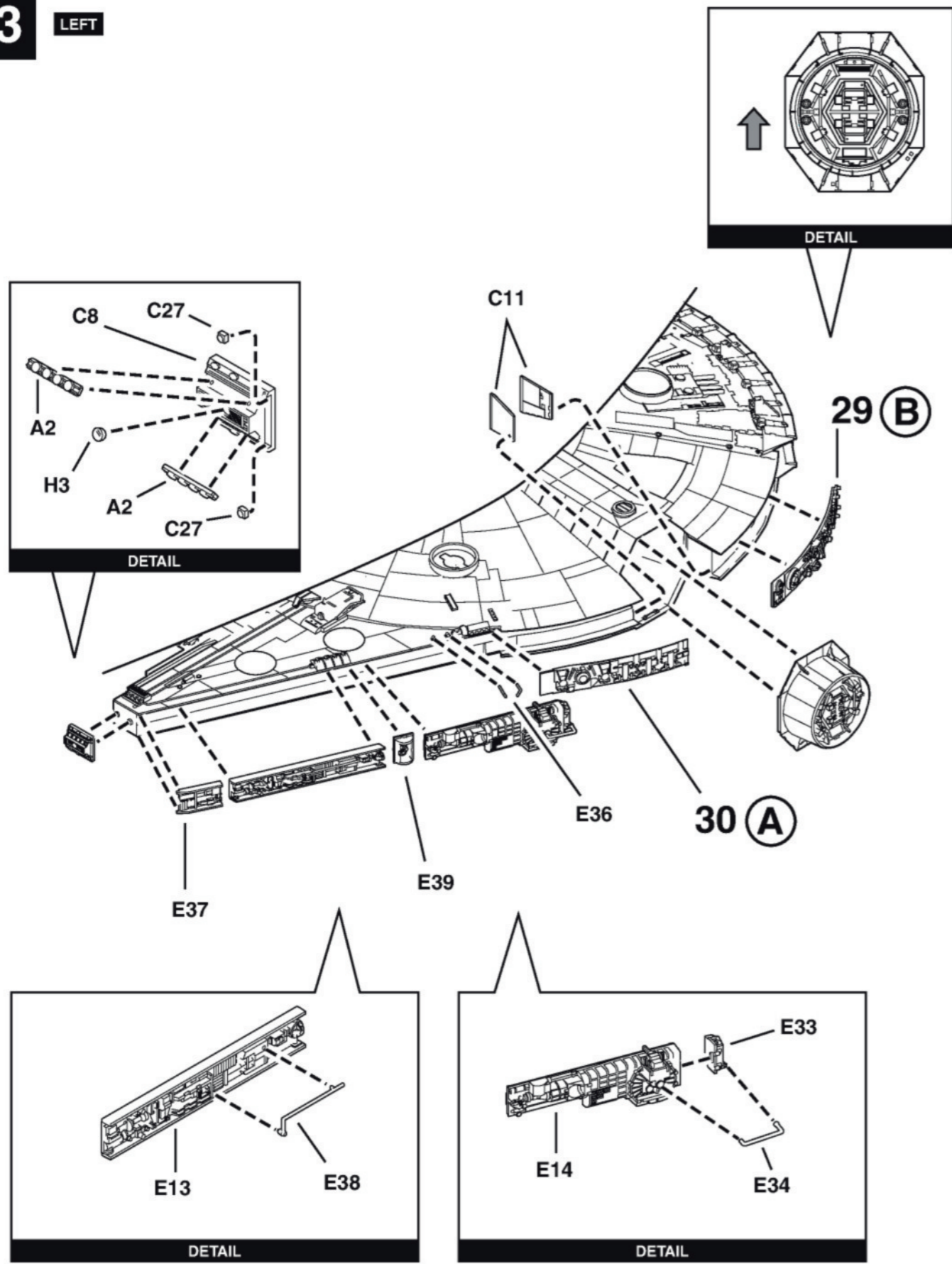

5

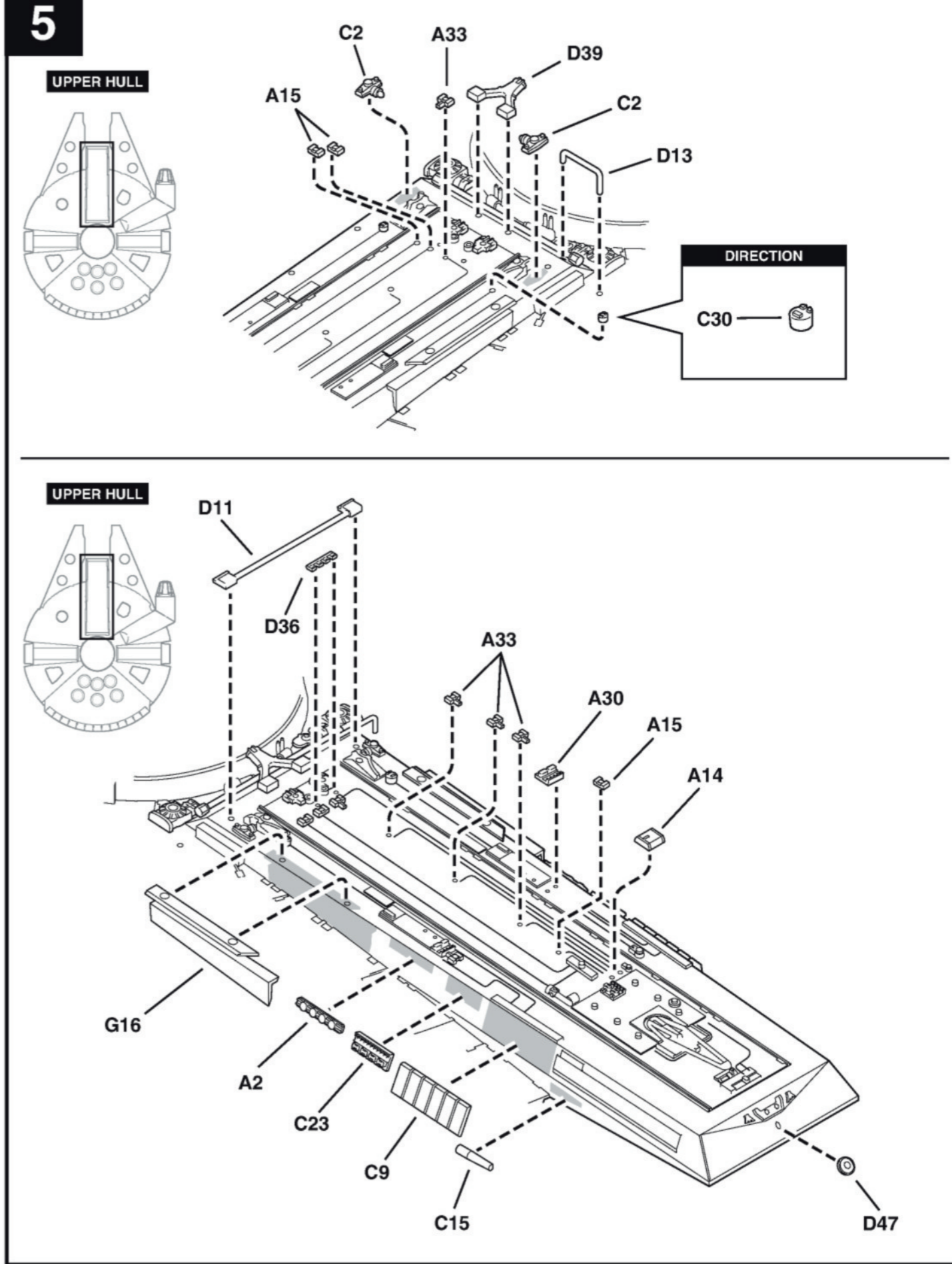

6

LEFT

UPPER HULL

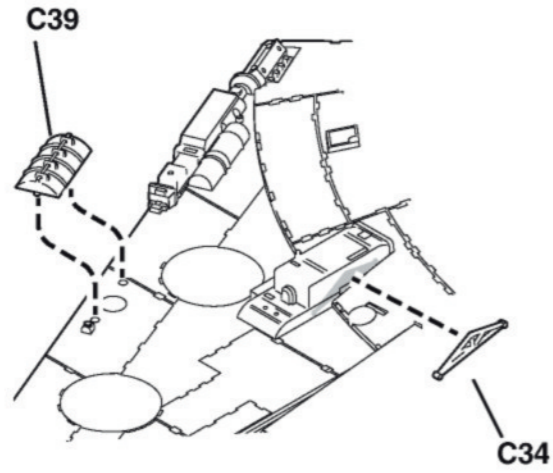
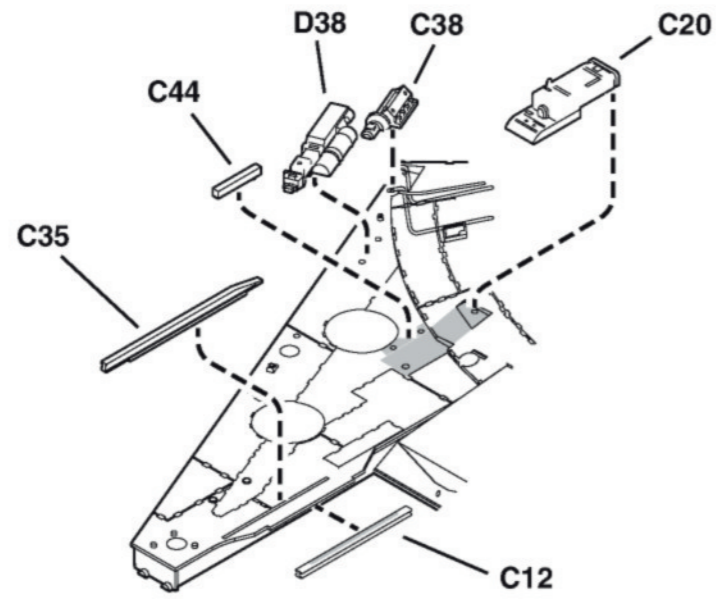

OTHER SIDE

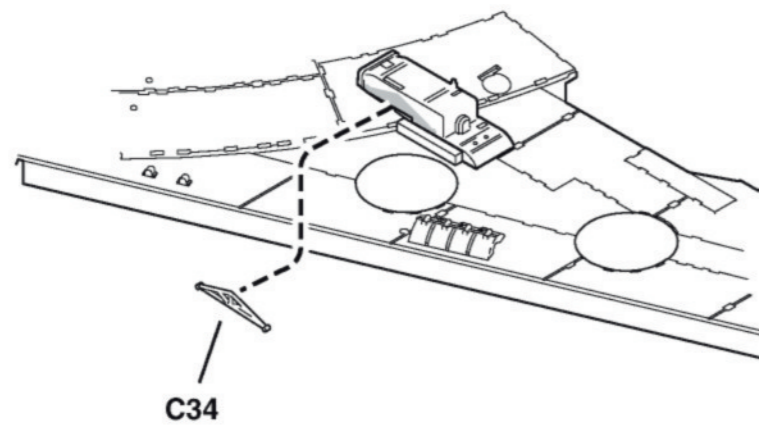

31

(A)

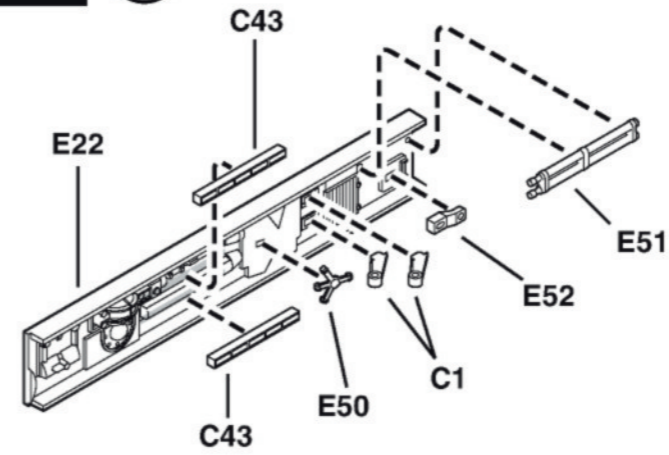

(B)

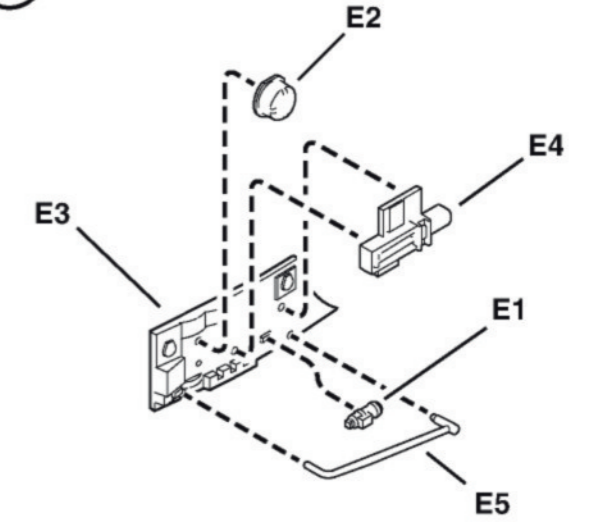

32

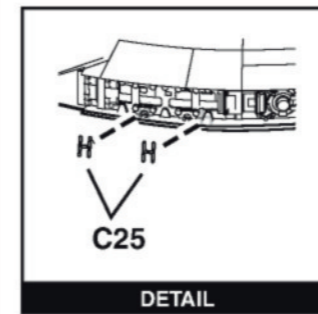

30 (C)

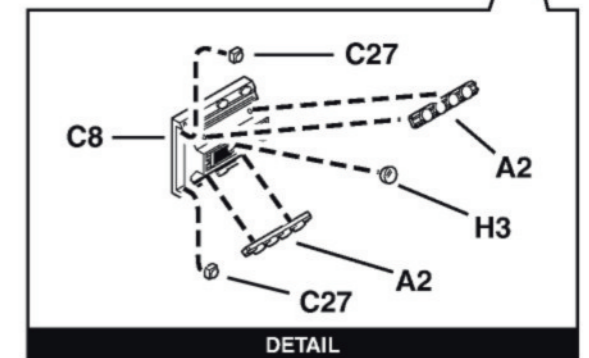
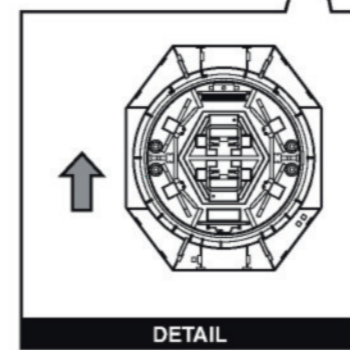
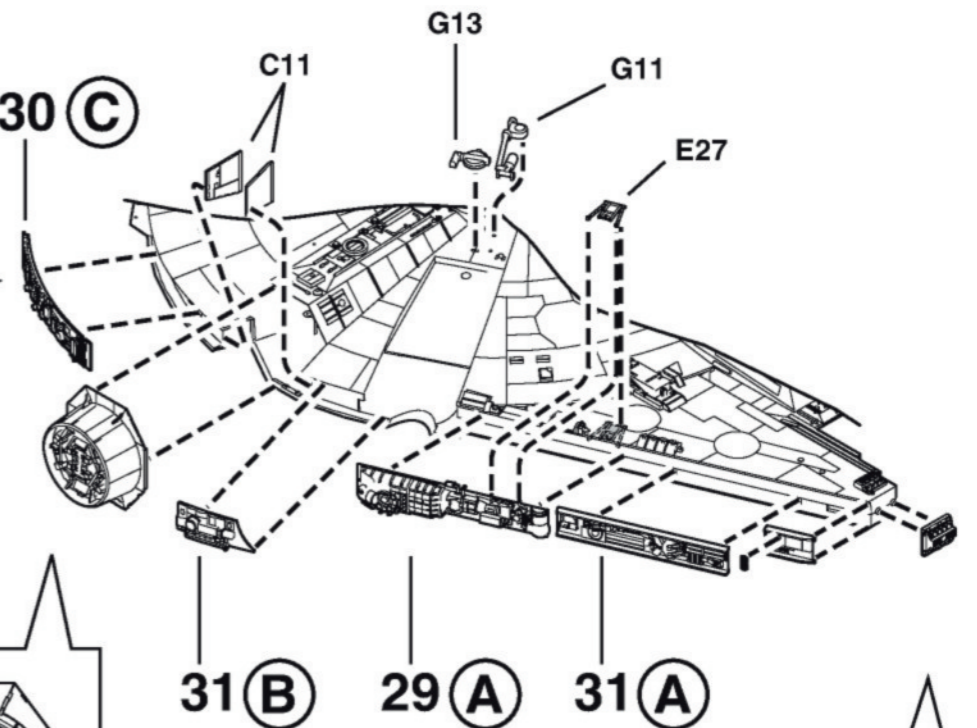

30

A

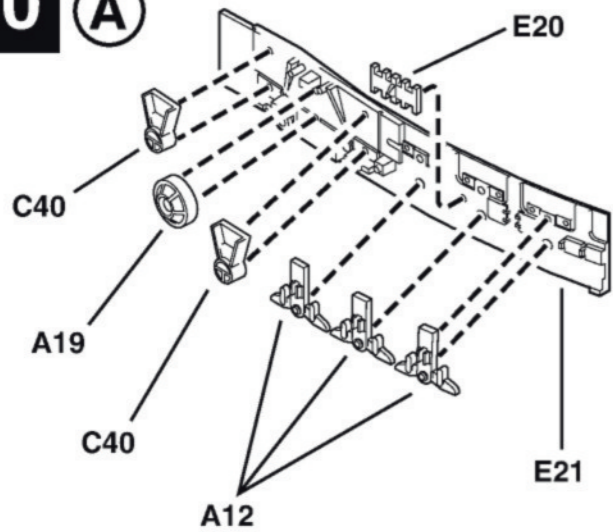

B

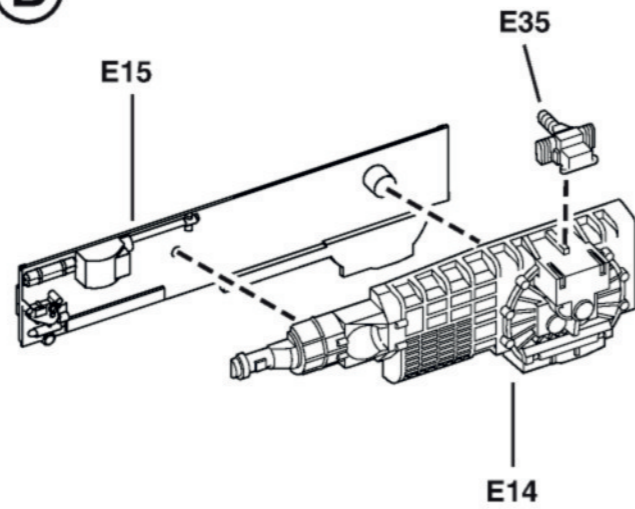

C

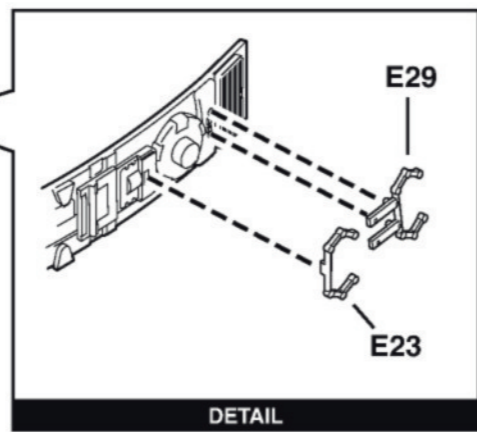
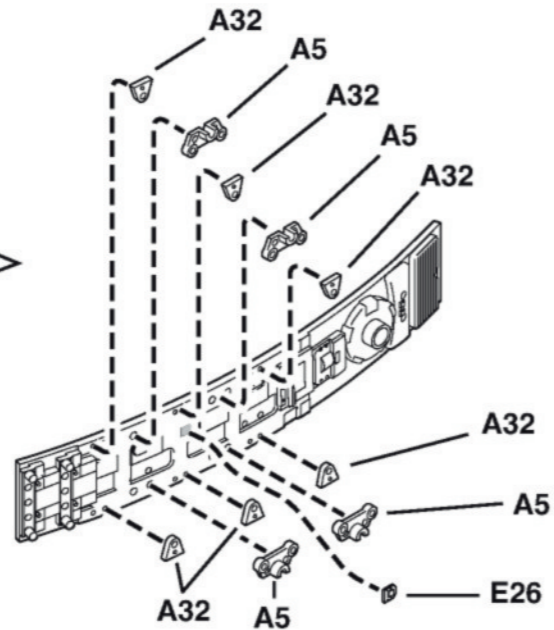
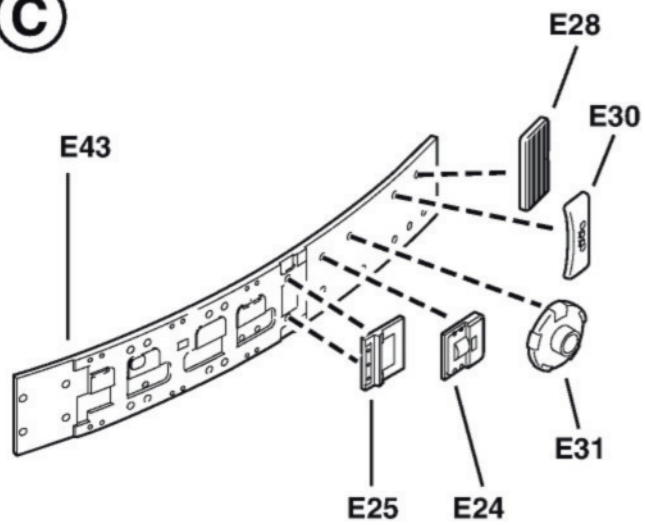

DETAIL

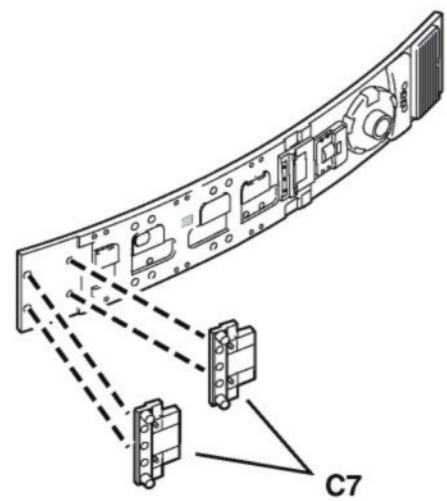

7

RIGHT

UPPER HULL

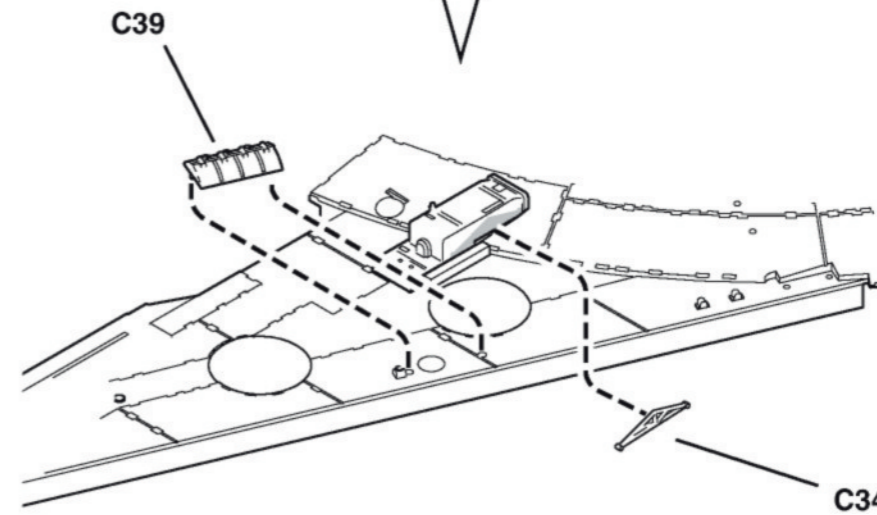
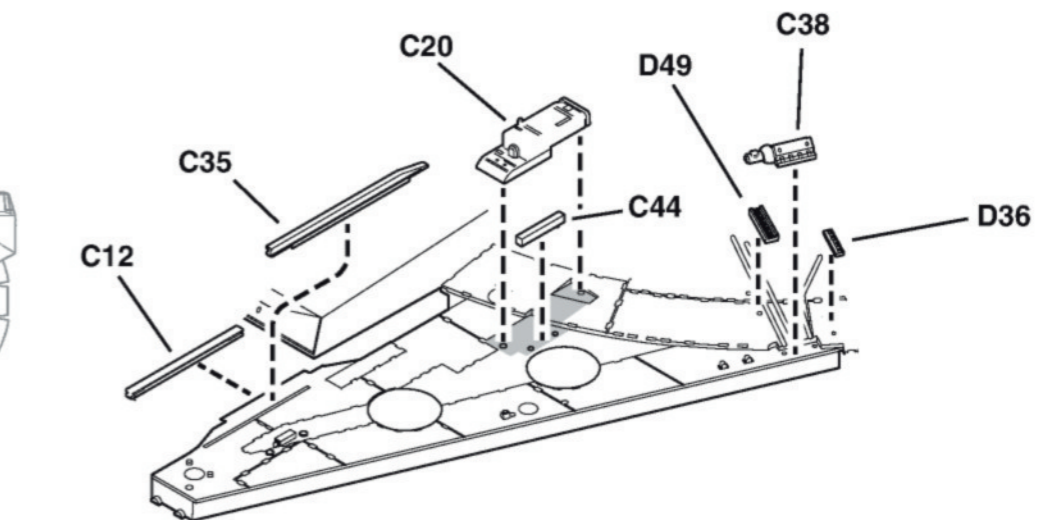
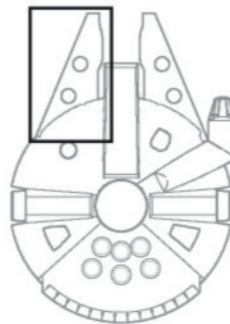

OTHER SIDE

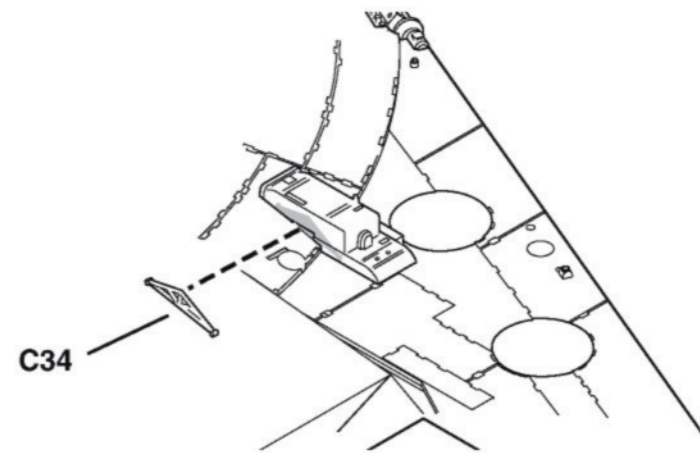

8

LEFT

UPPER HULL

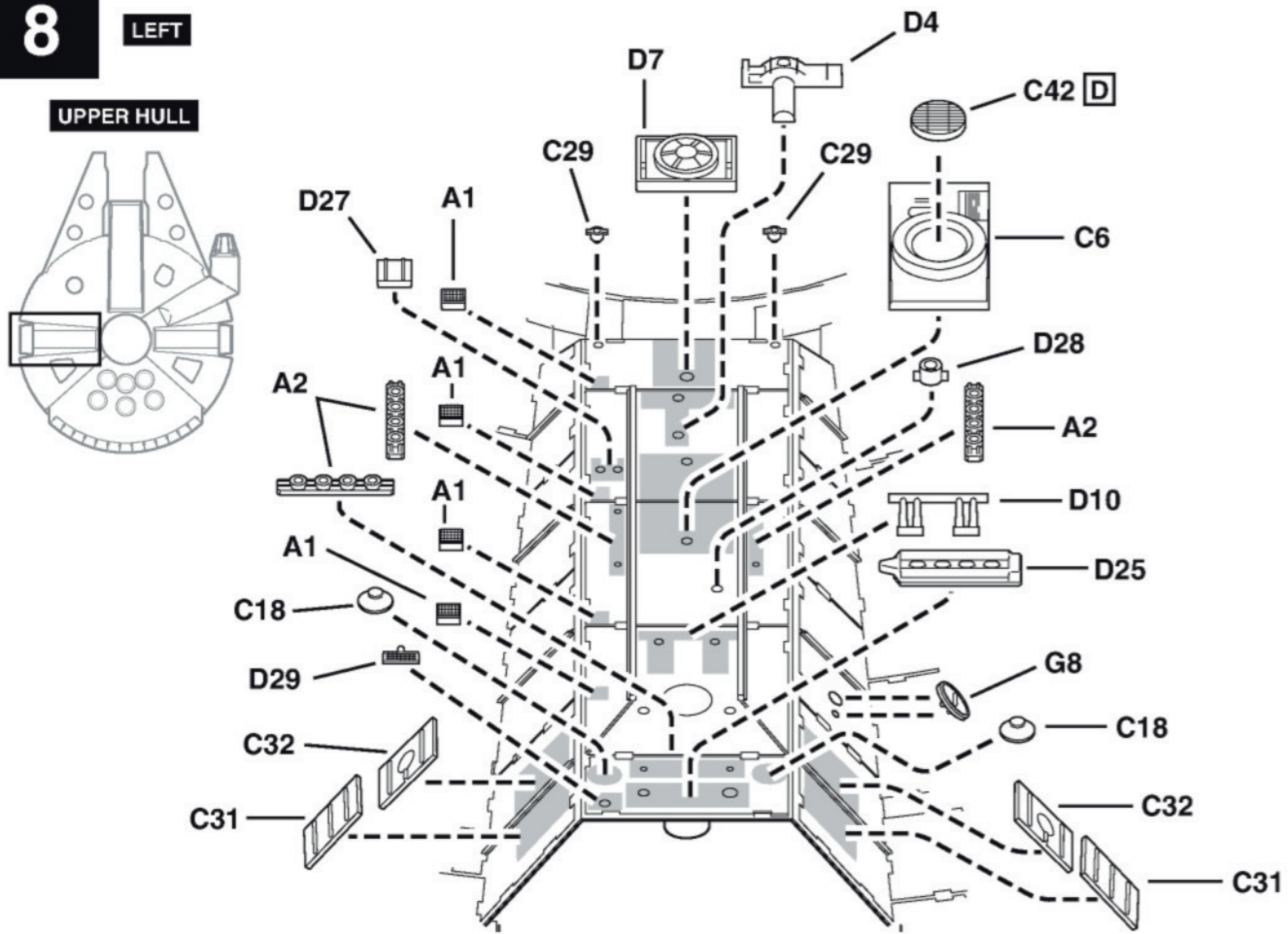

RIGHT

UPPER HULL

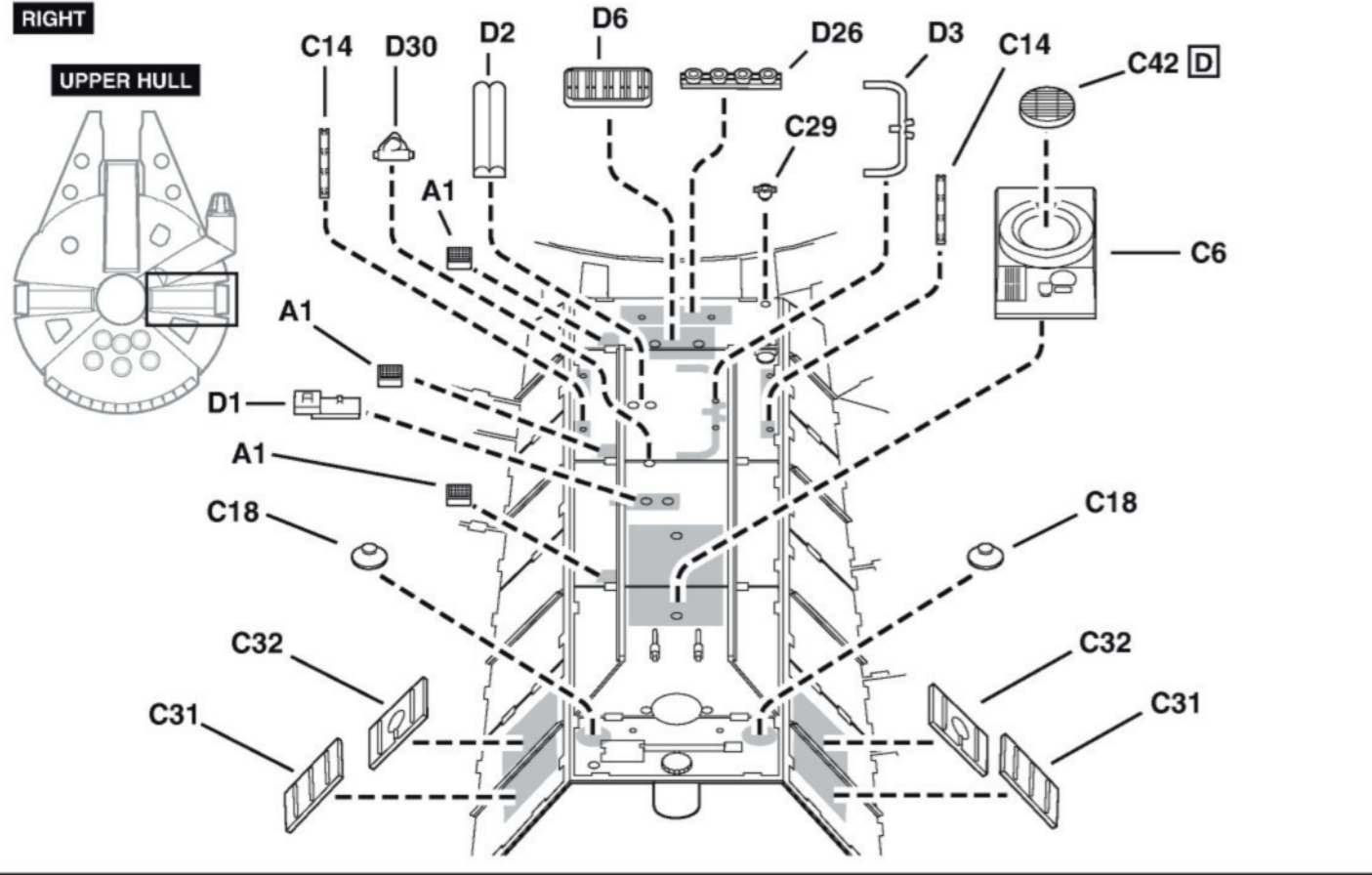

29

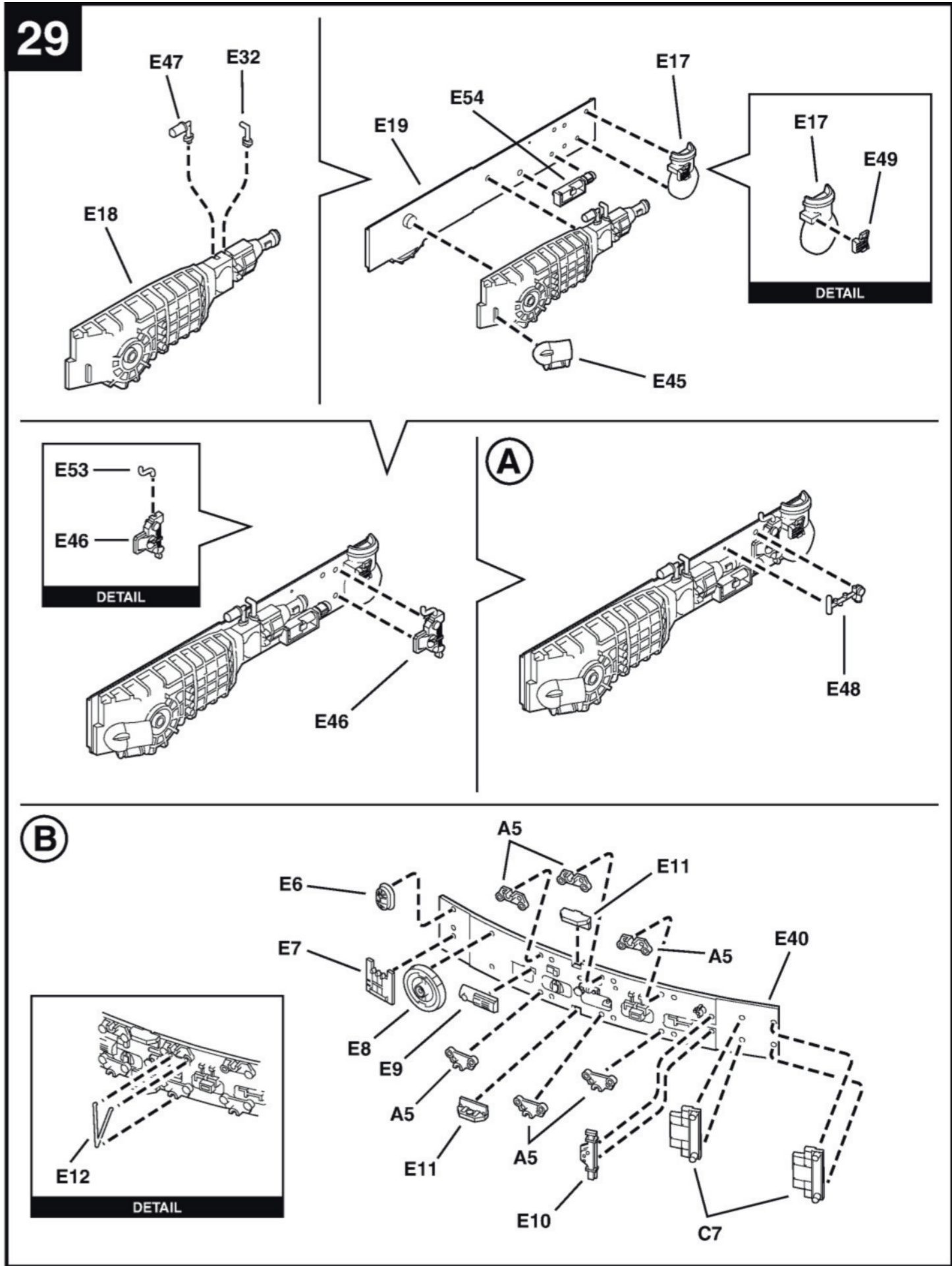

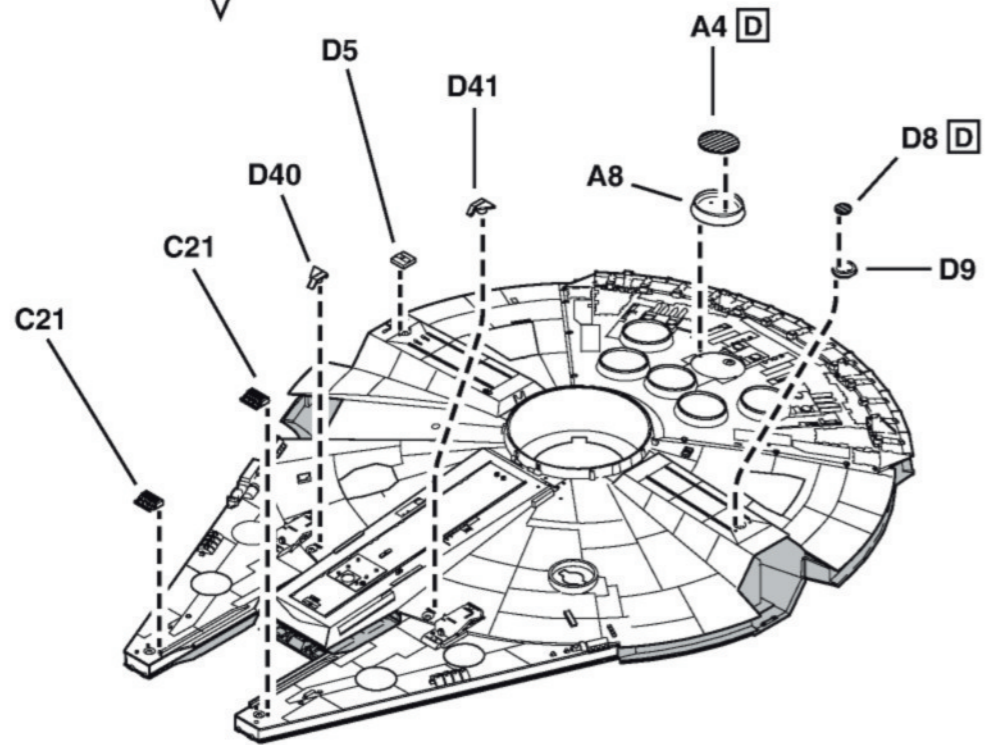
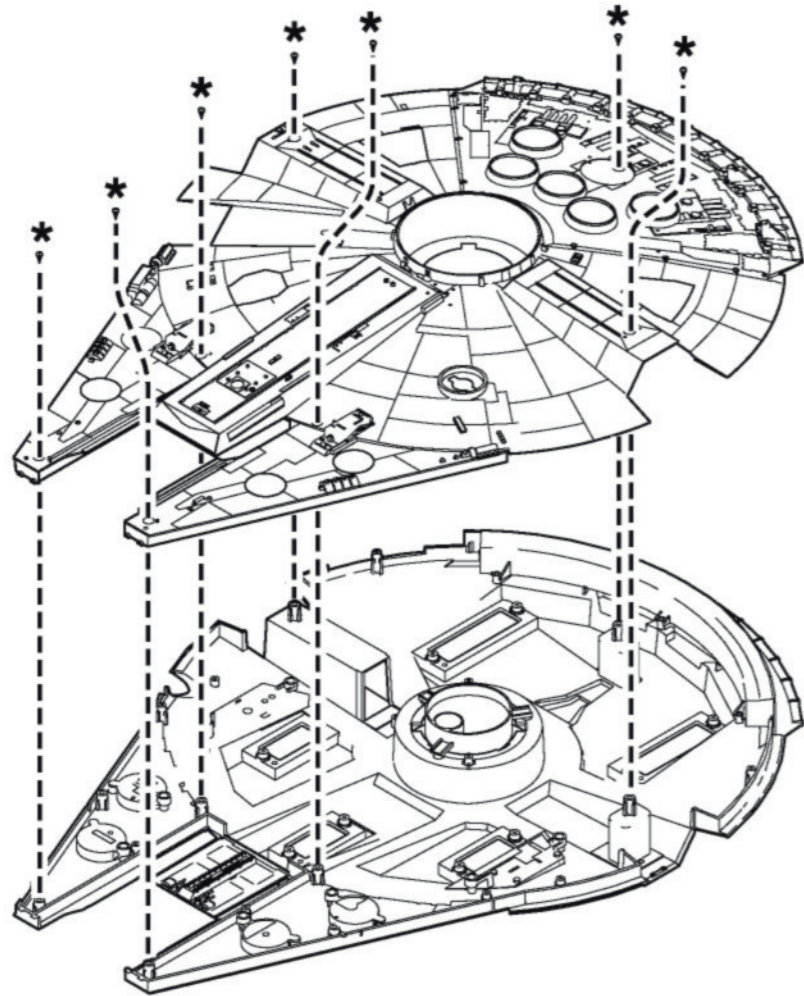

(A)

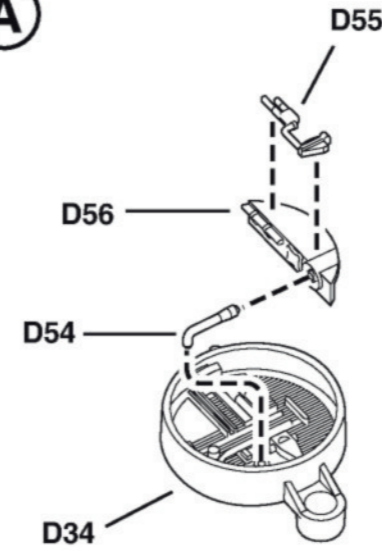

(B)

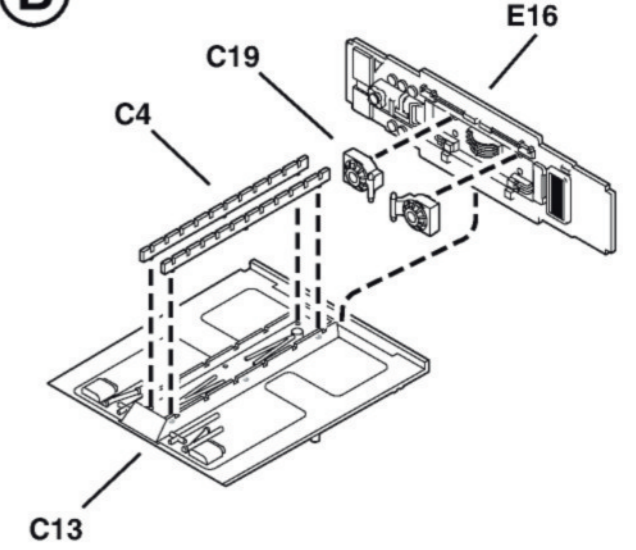

(C)

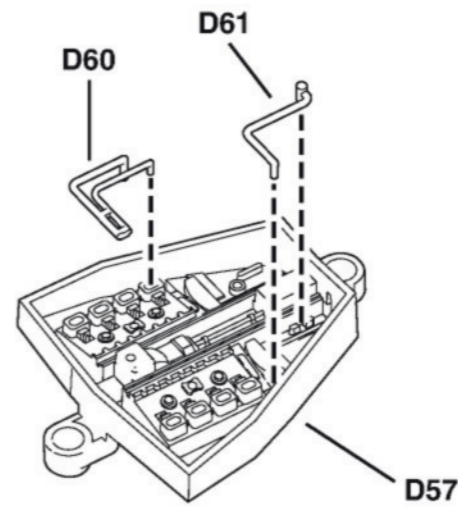

(D)

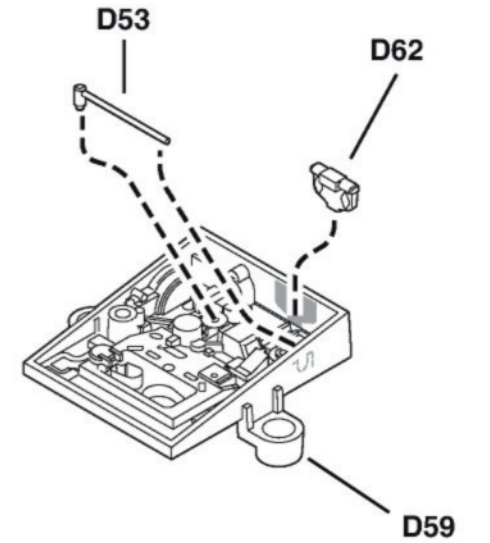

(E)

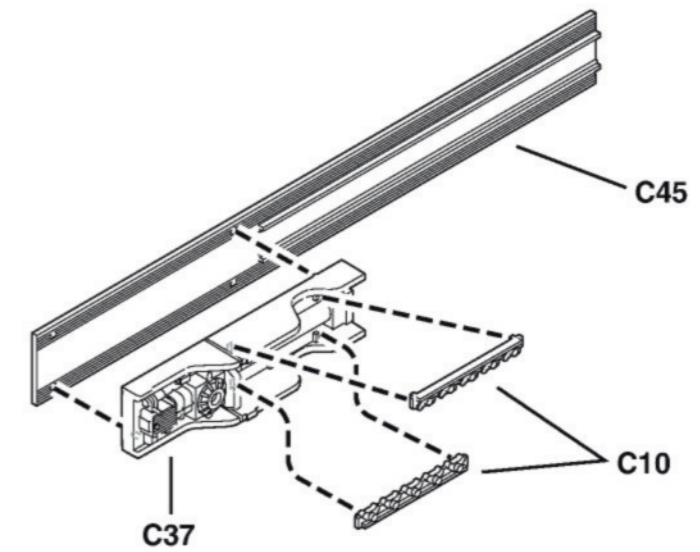

10



UPPER HULL

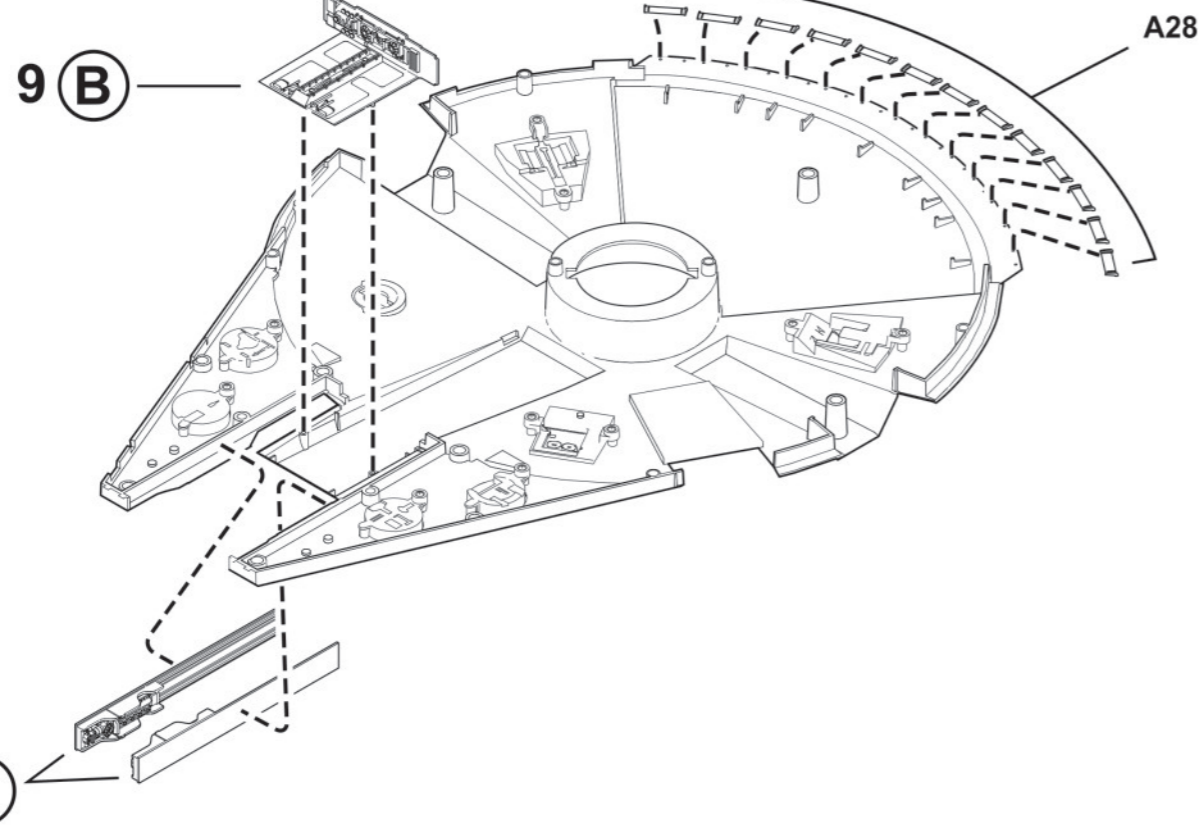
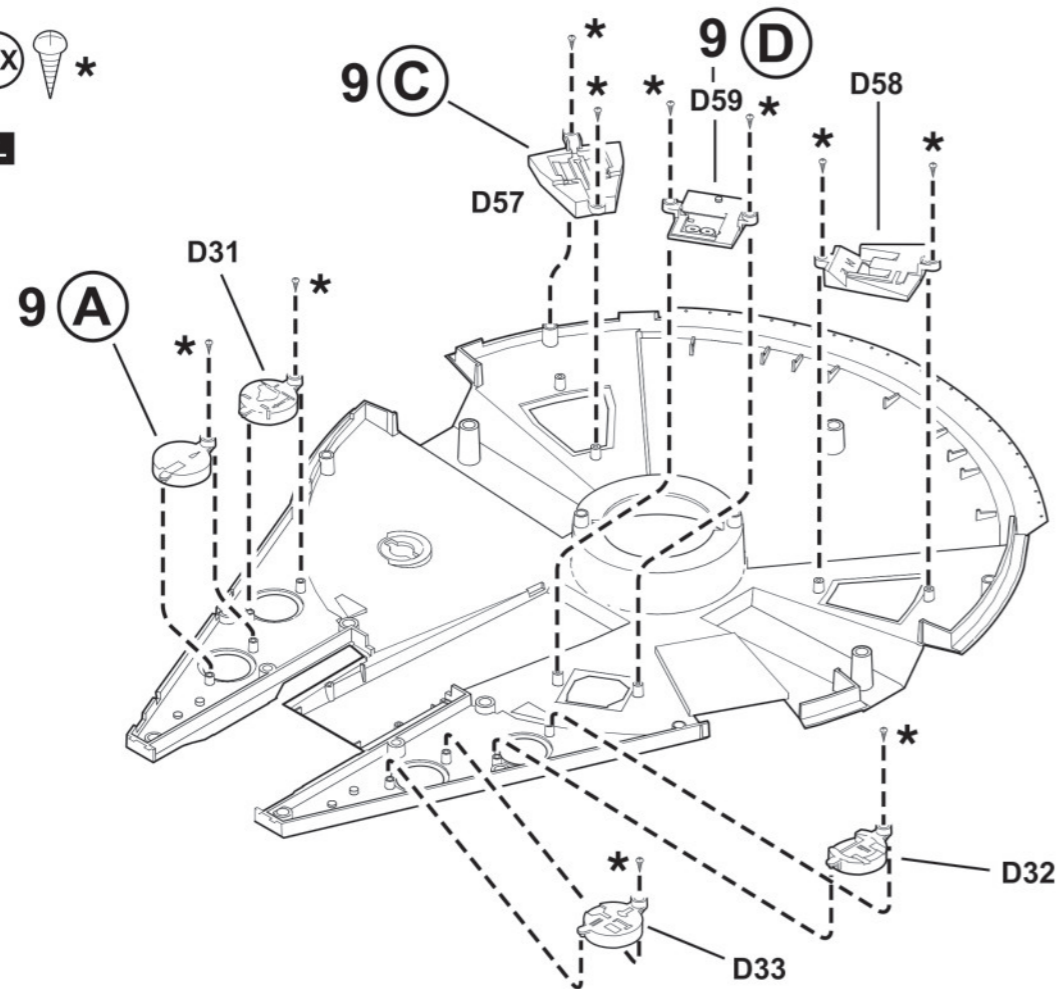

27

RIGHT

UPPER HULL

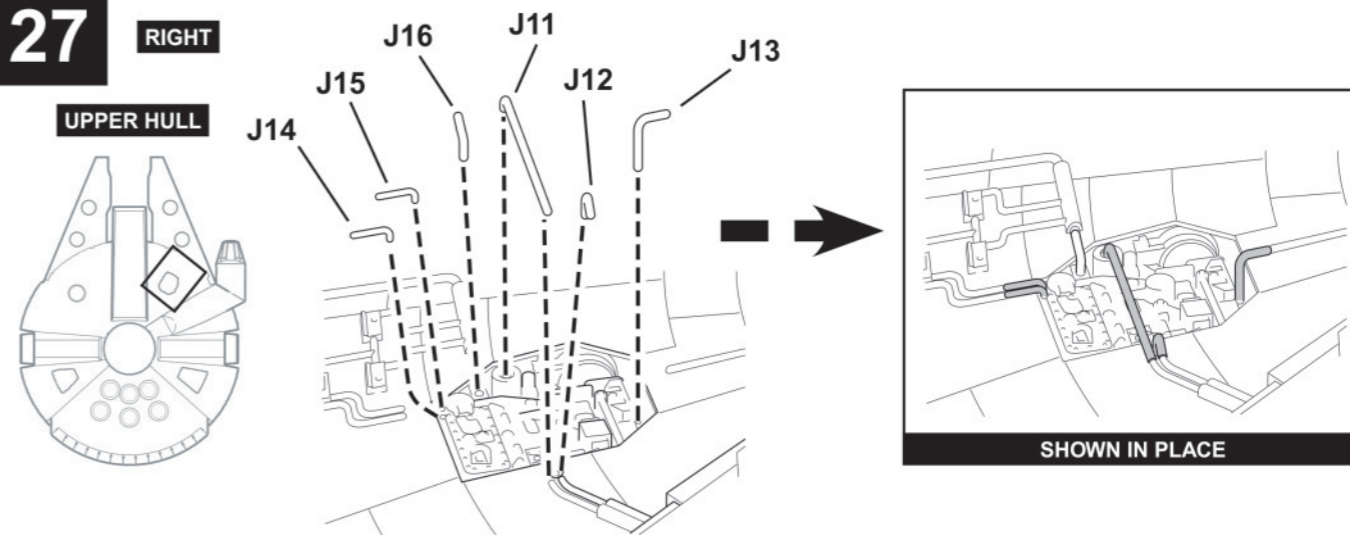

RIGHT

UPPER HULL

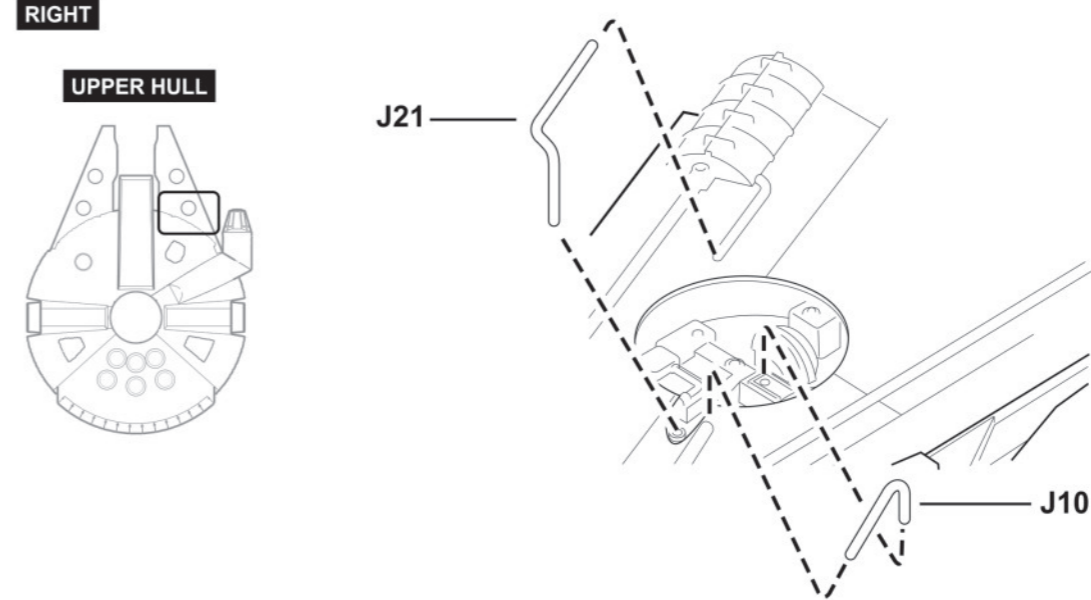

LEFT

UPPER HULL

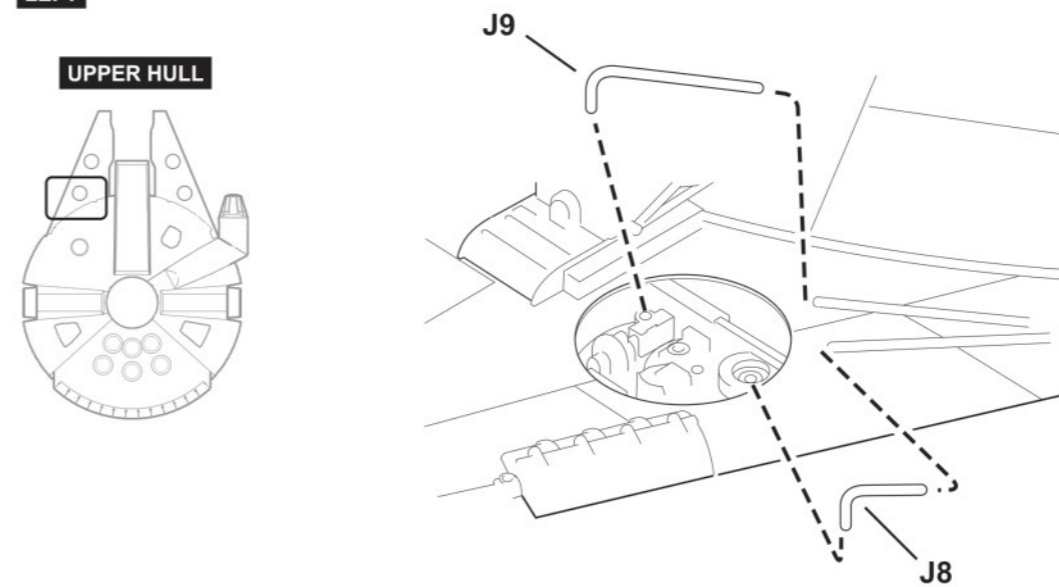

26

LEFT

LOWER HULL

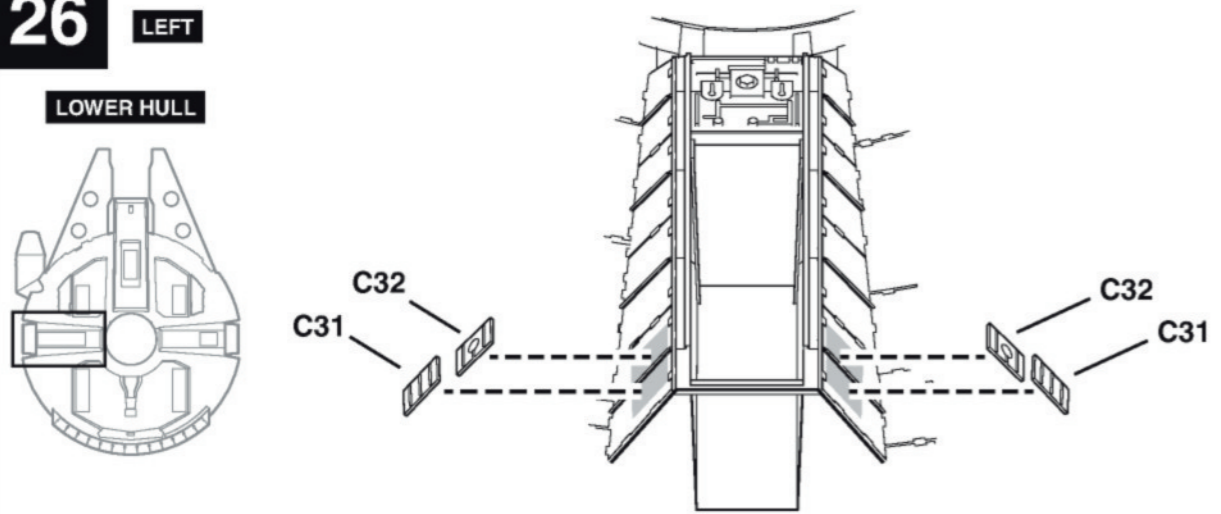

LEFT

UPPER HULL

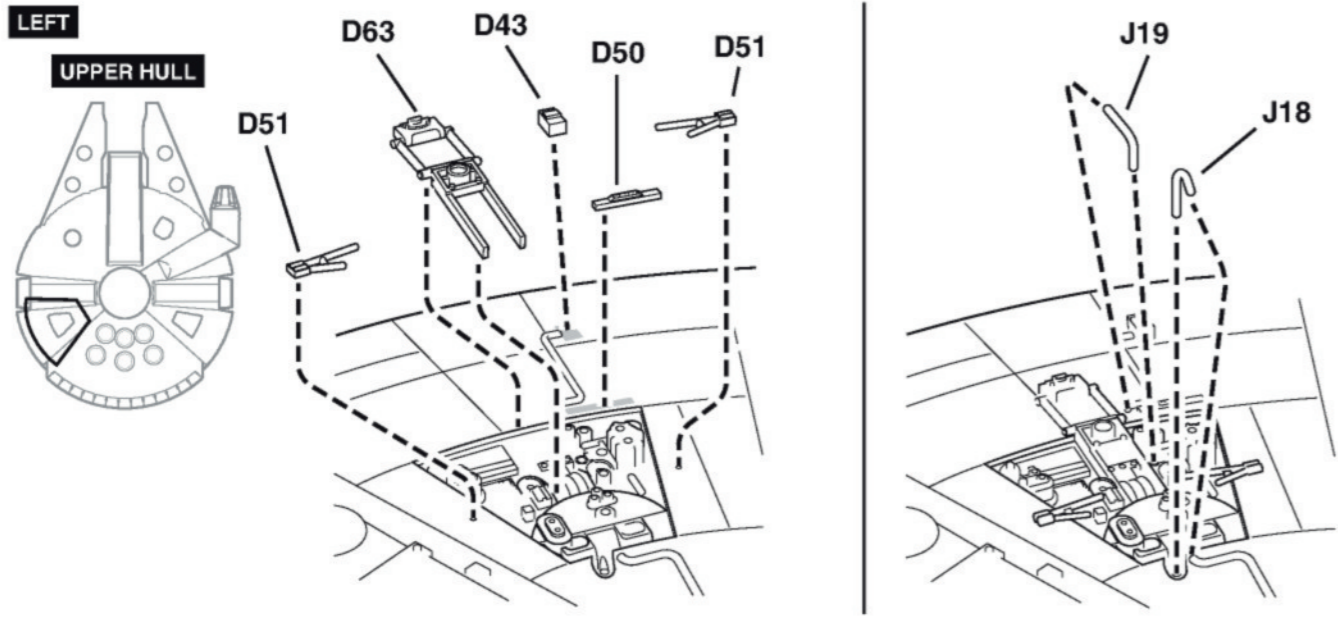

RIGHT

UPPER HULL

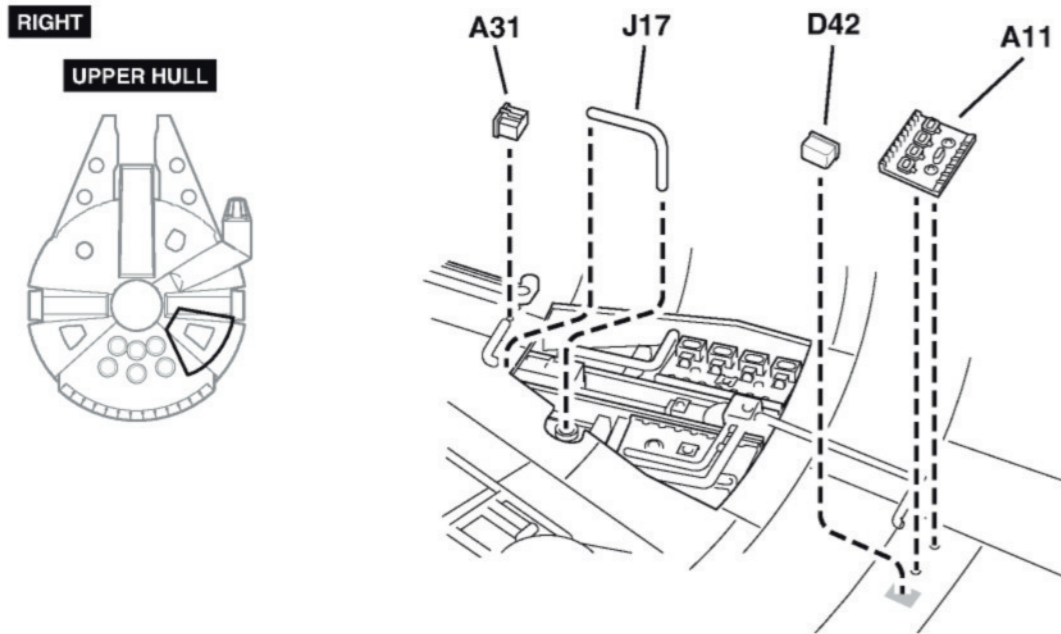

11

UPPER HULL

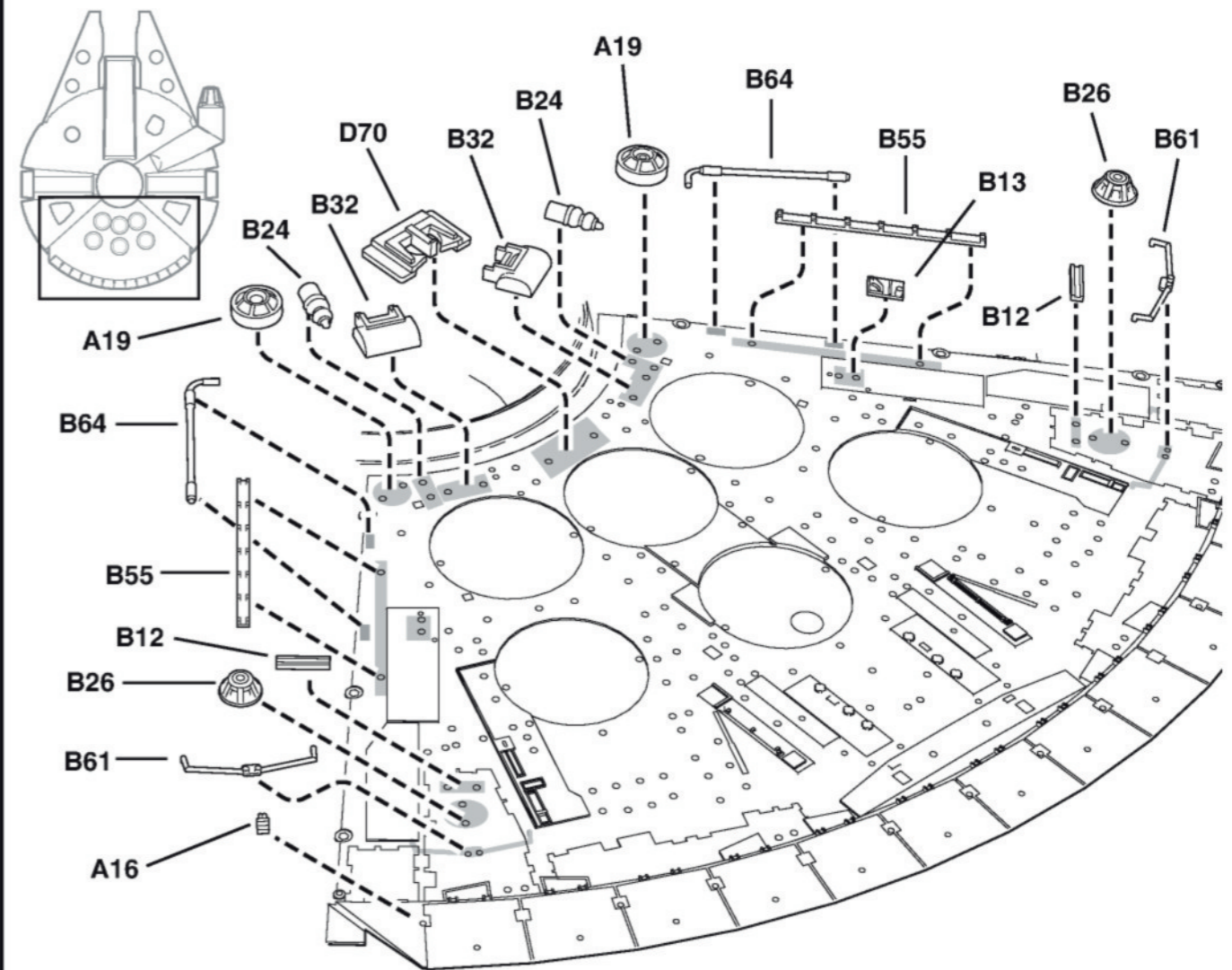

A



B

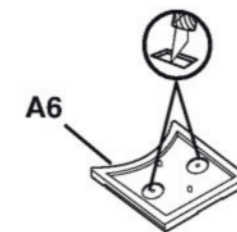

NOTE: REMOVE MATERIAL TO A DEPTH OF THE 1.2MM.
 REMARQUE : RETIRER DU MATÉRIEL À UNE ÉPAISSEUR DE 1,2 MM.
 NOTA: RETIRE EL MATERIAL A UNA PROFUNDIDAD DE 1.2MM.

C

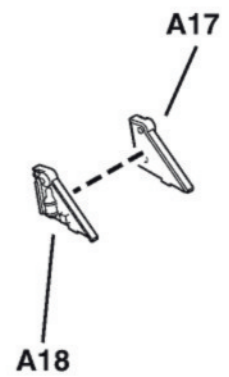

UPPER HULL

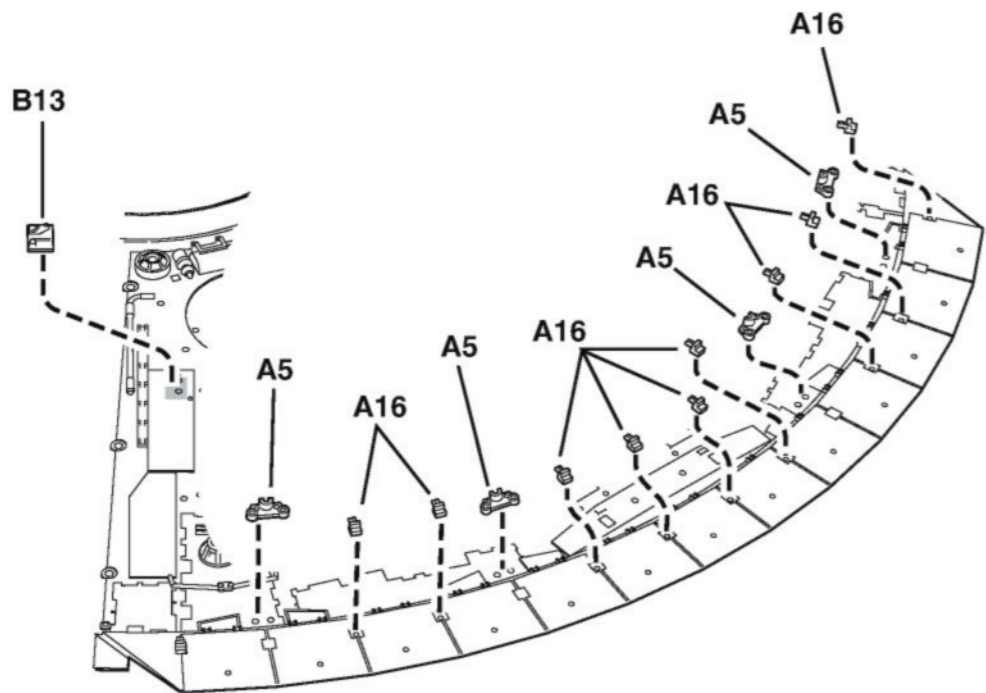

UPPER HULL

11 (B)

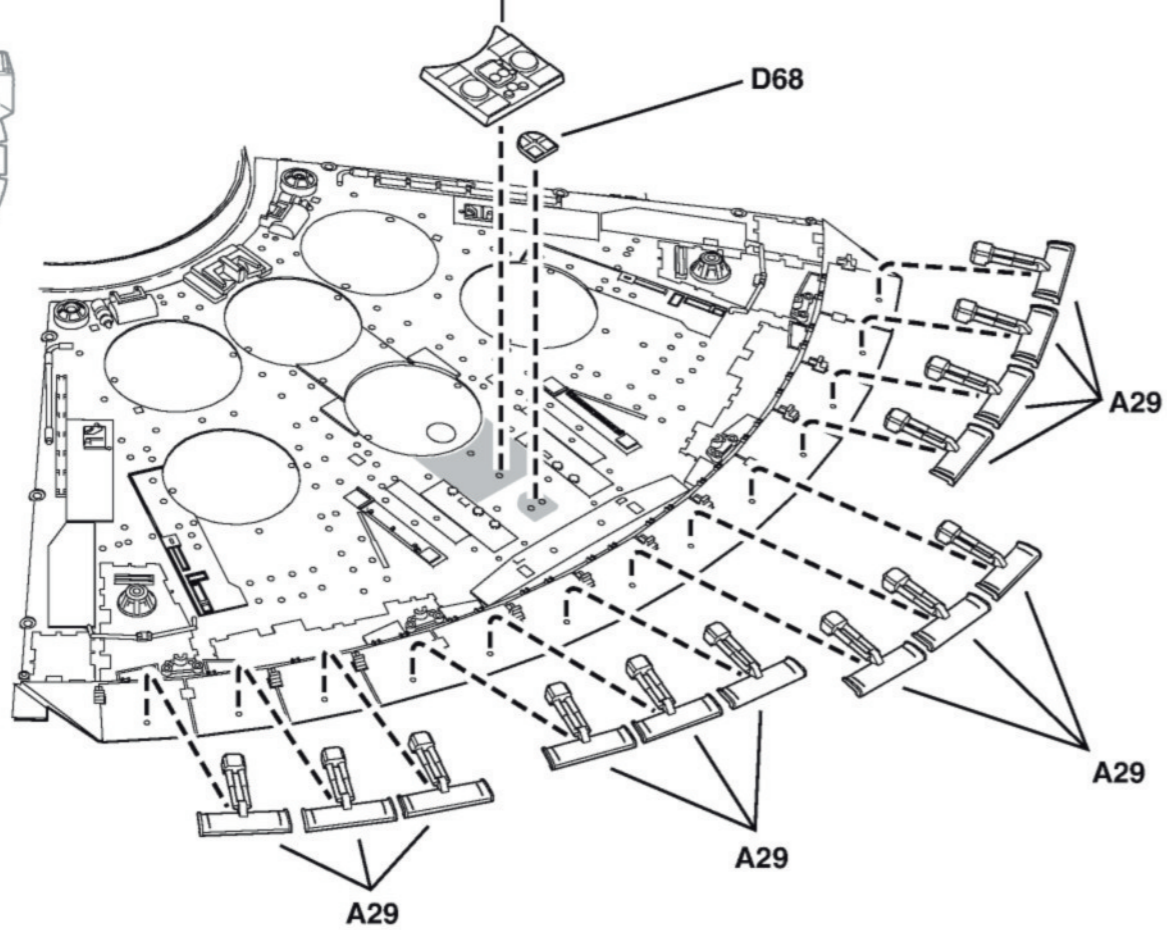

RIGHT

LOWER HULL

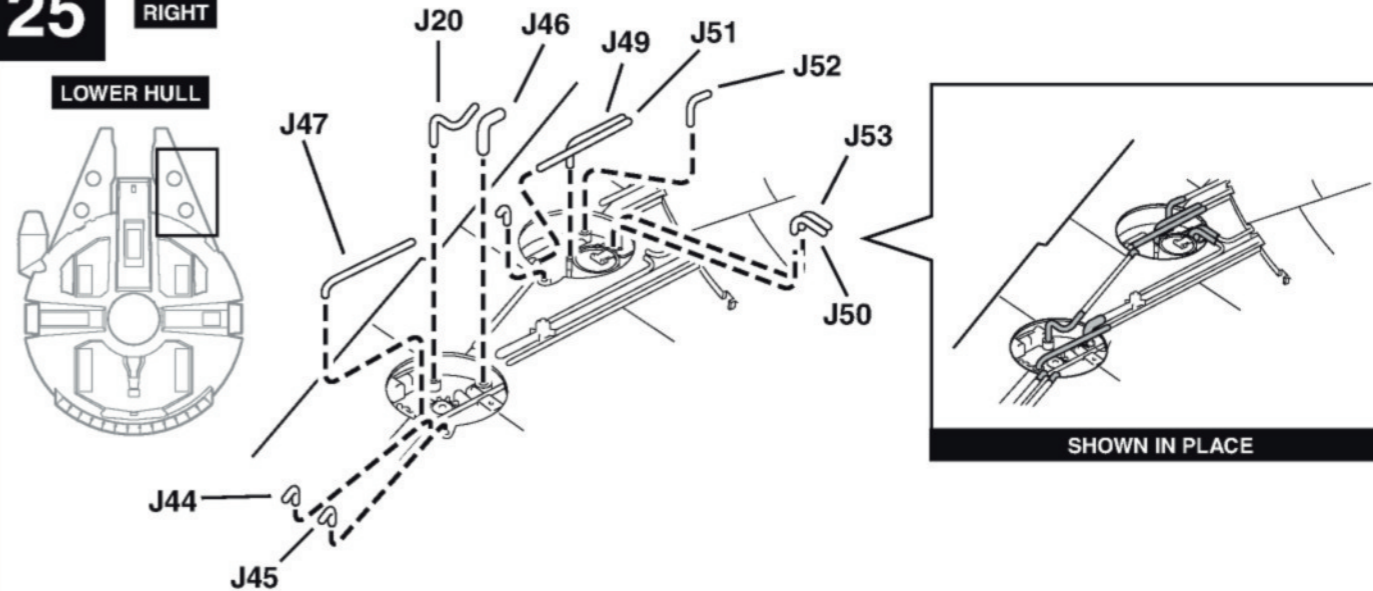

LEFT

LOWER HULL

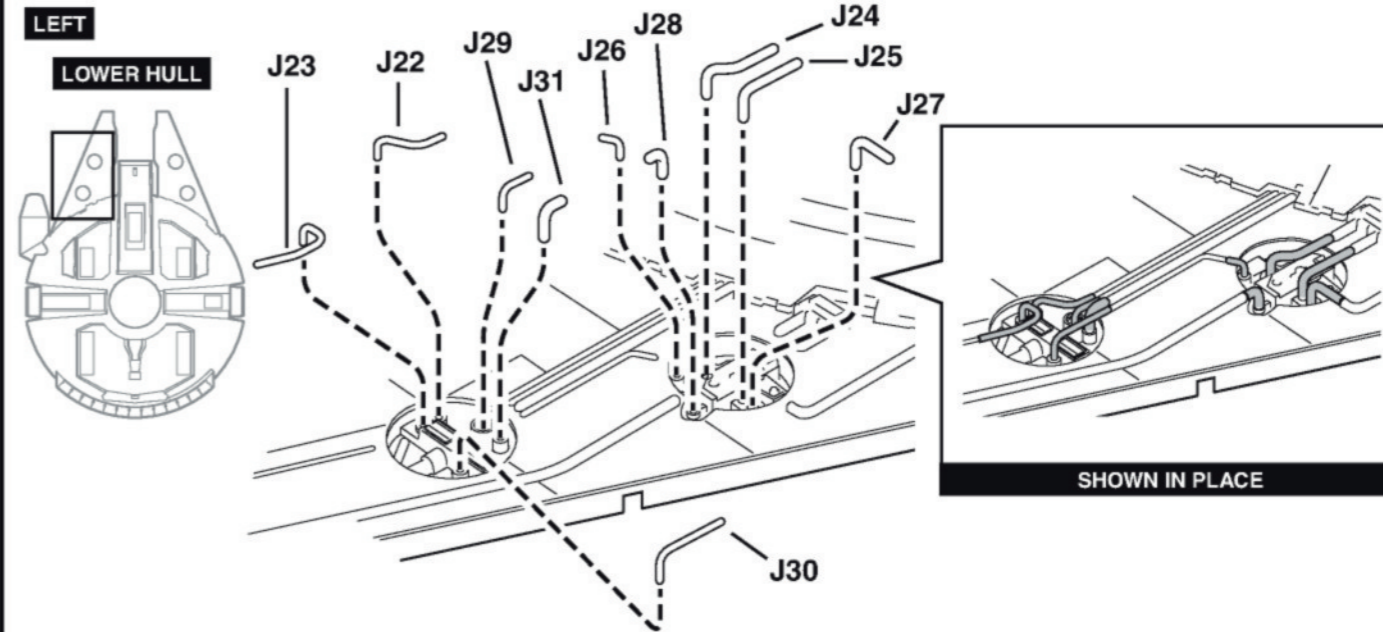

RIGHT

LOWER HULL

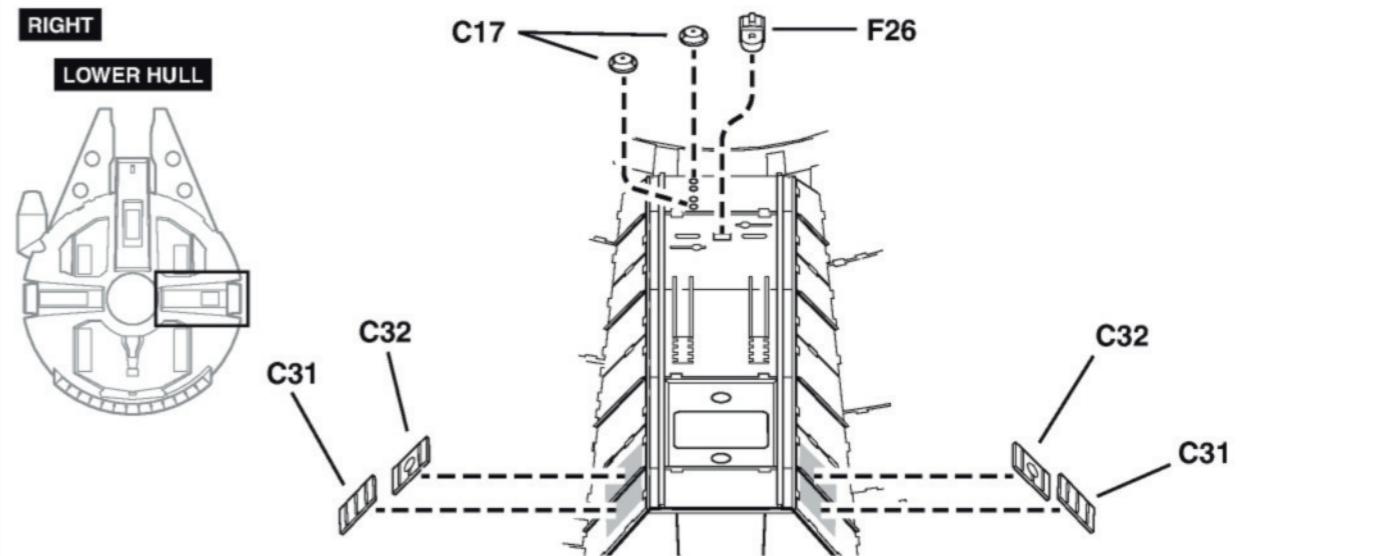

24

LOWER HULL

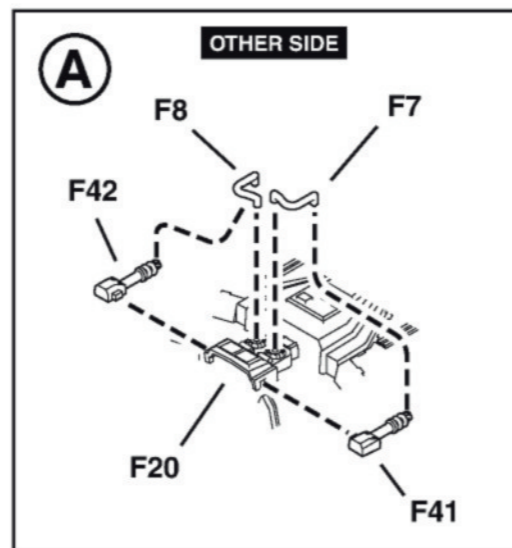
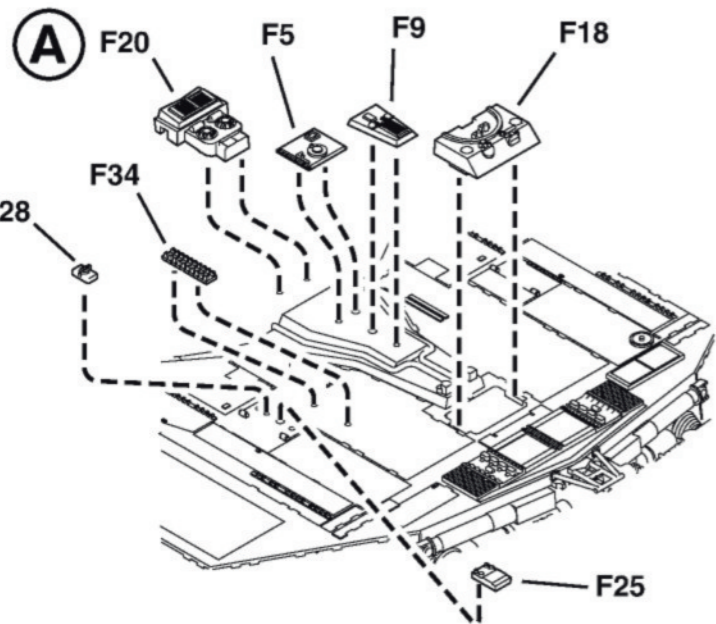
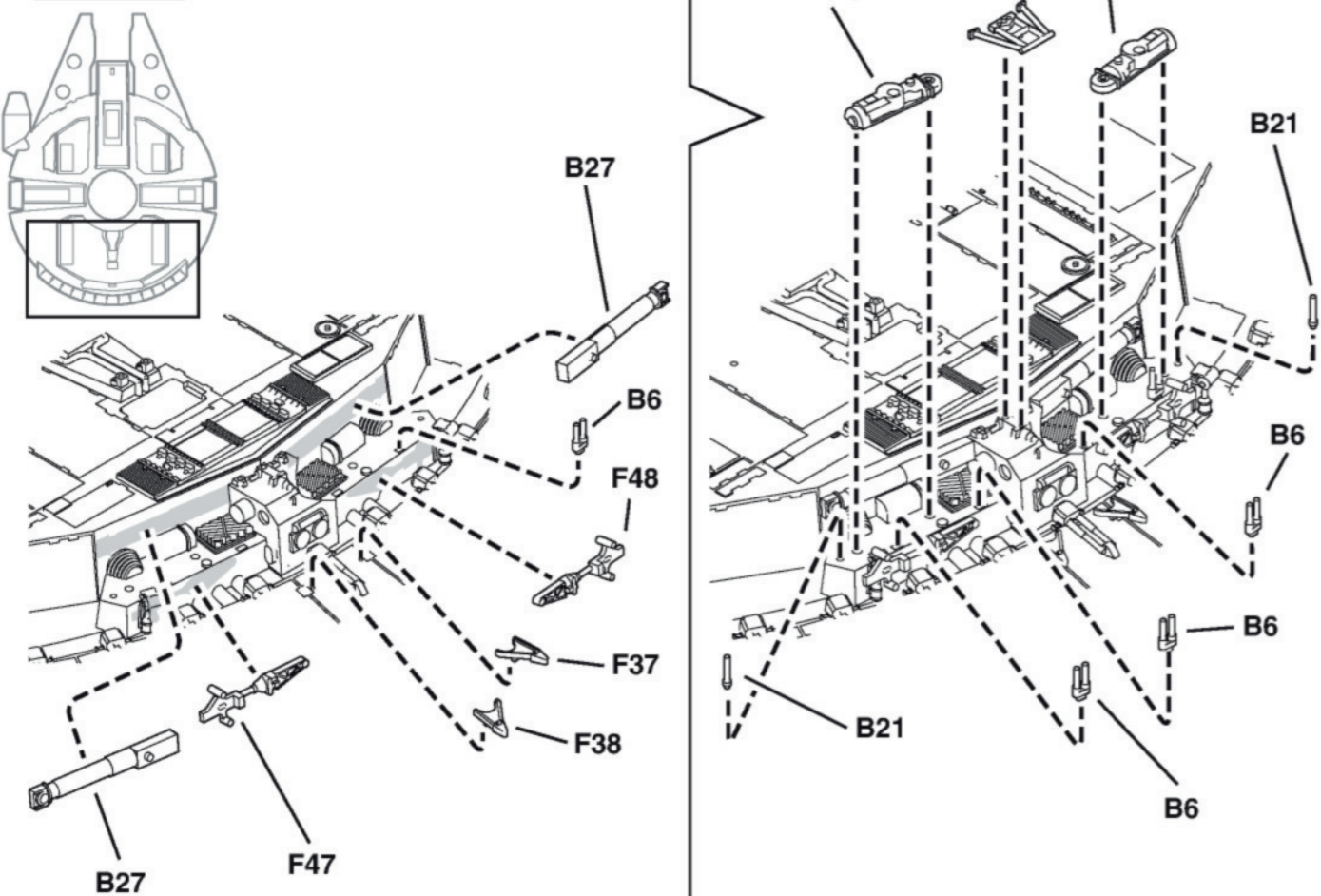

13

UPPER HULL

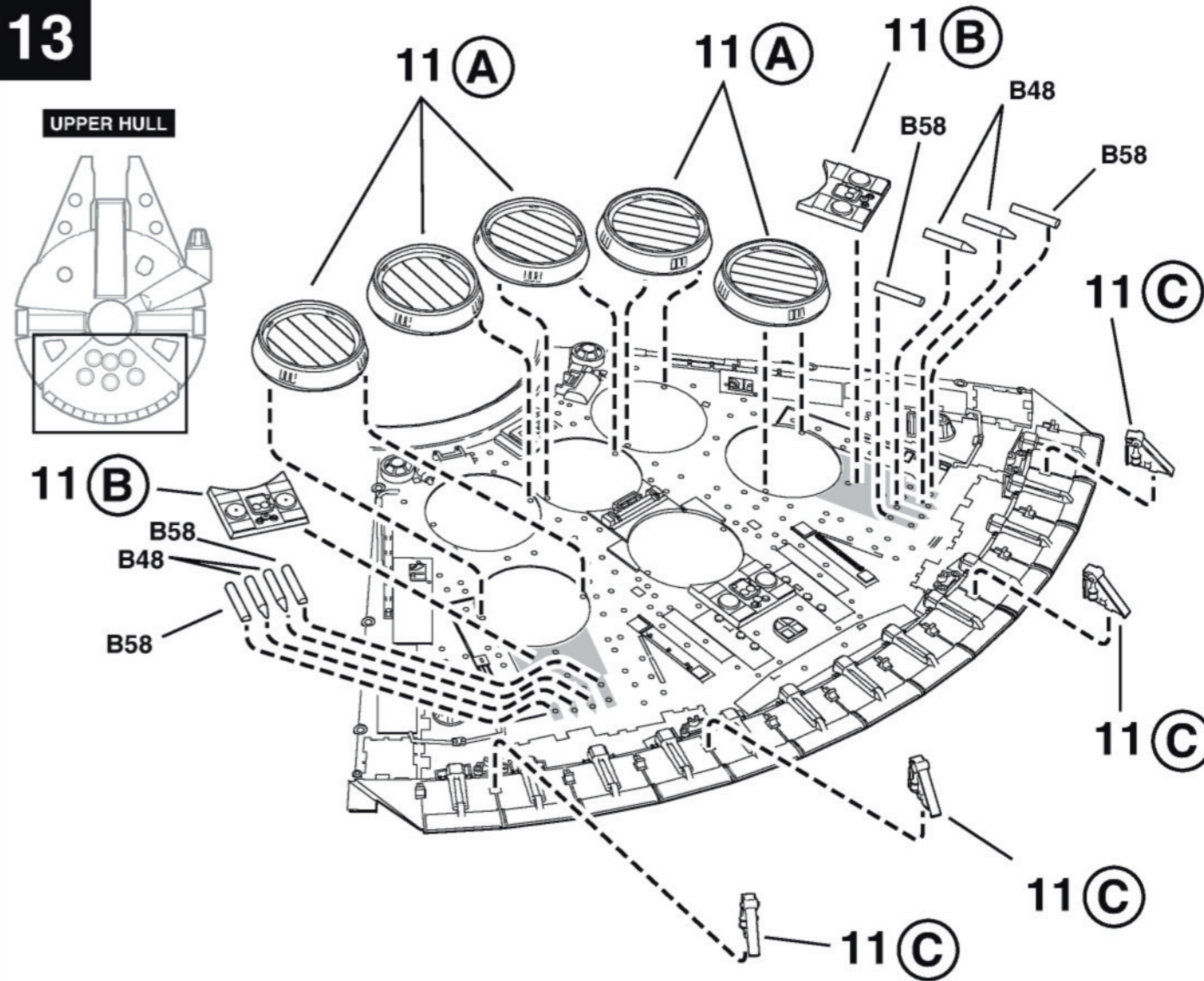

UPPER HULL

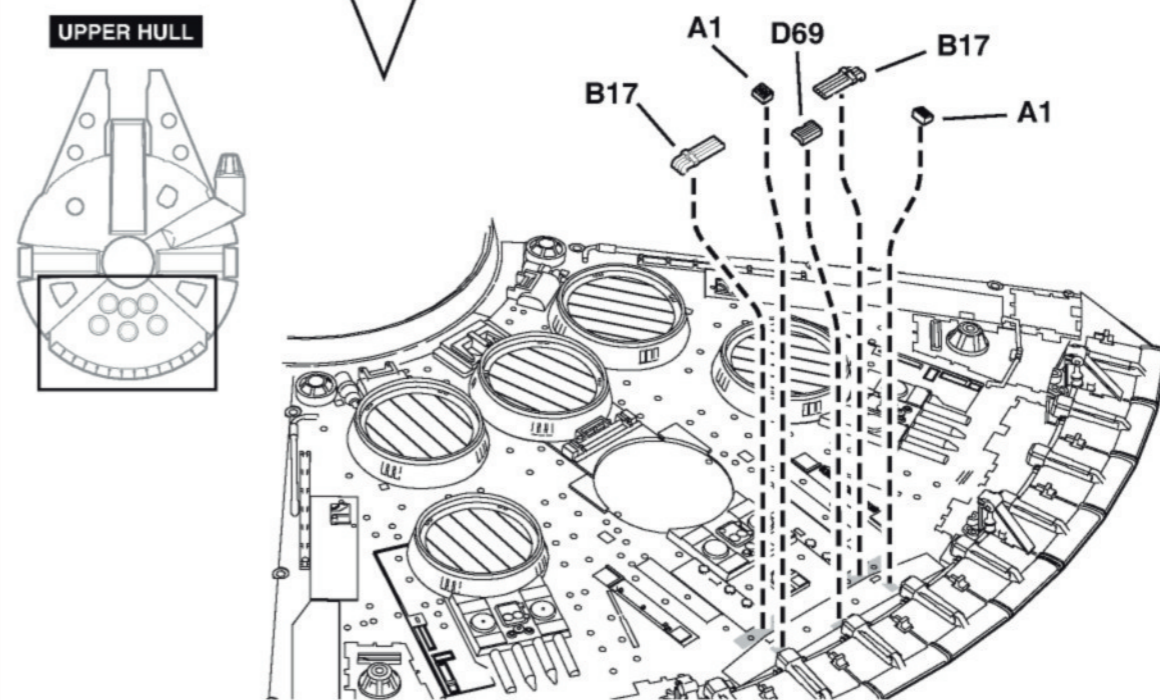

UPPER HULL

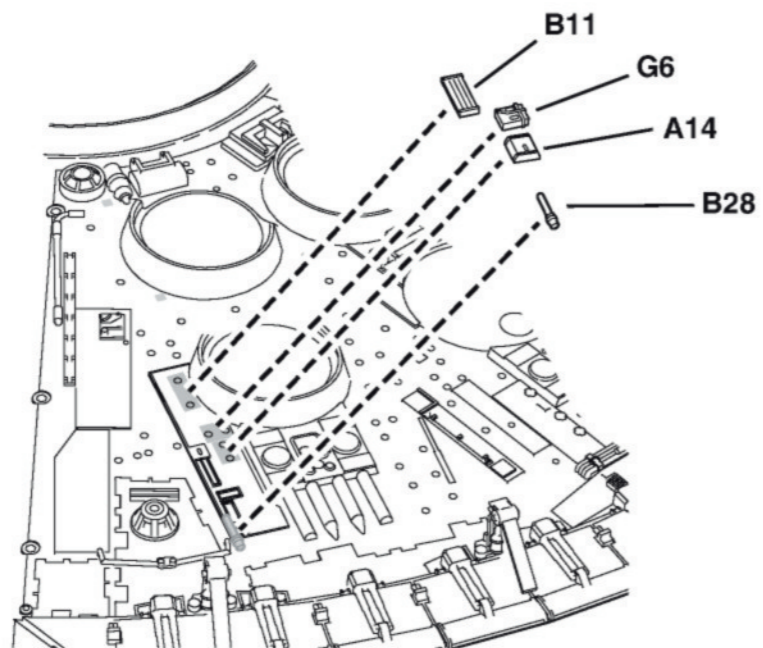
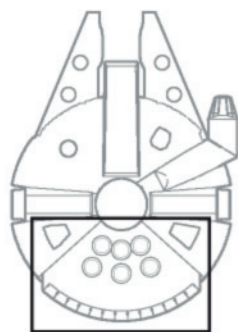

UPPER HULL

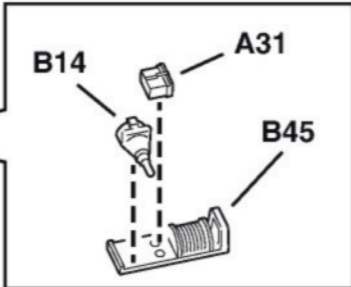
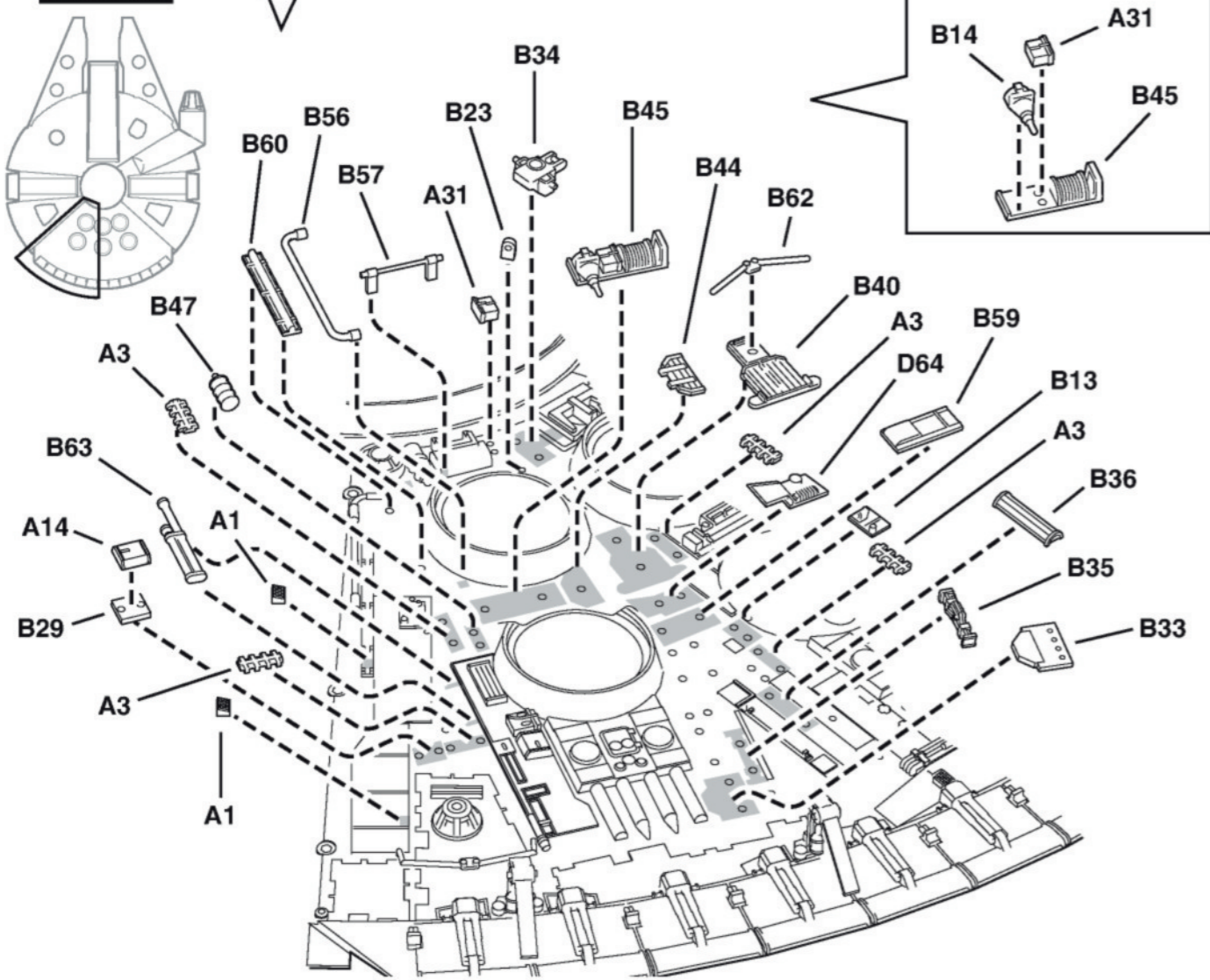
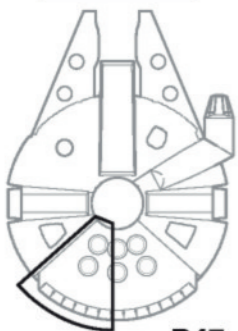

LOWER HULL

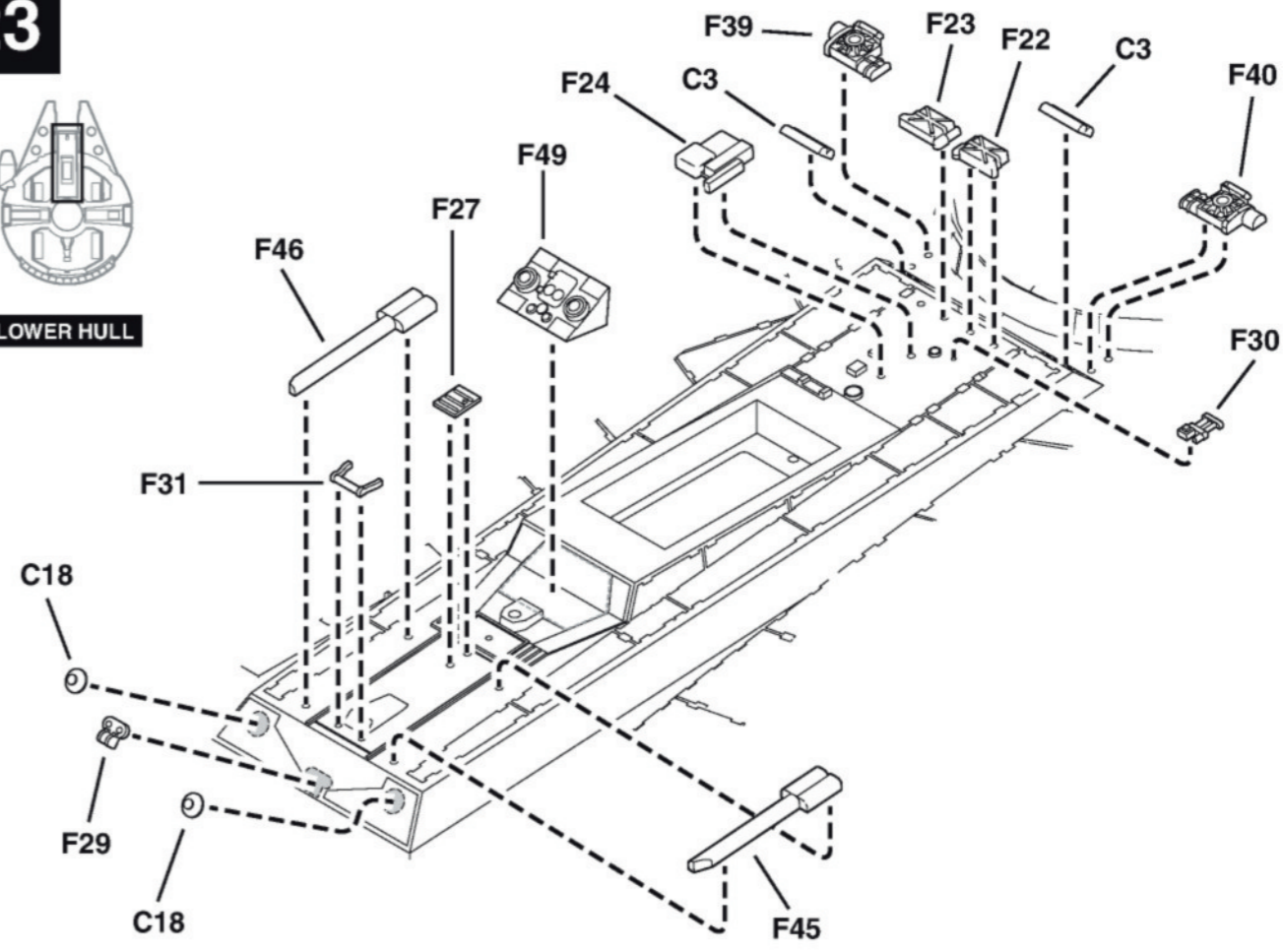

LOWER HULL

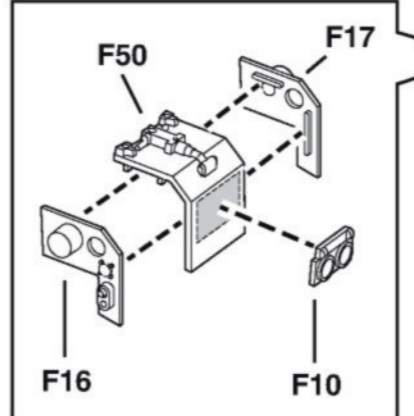
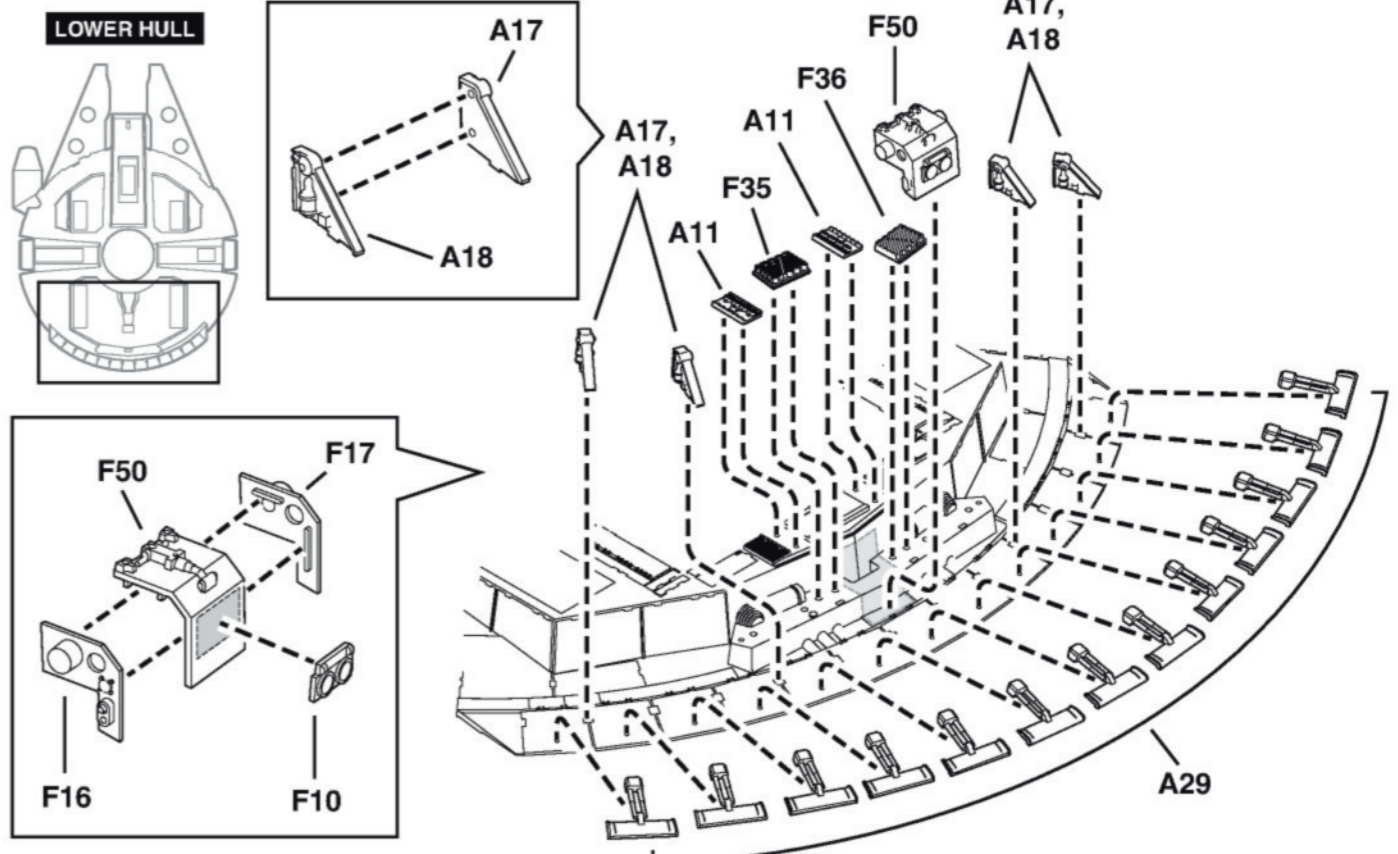
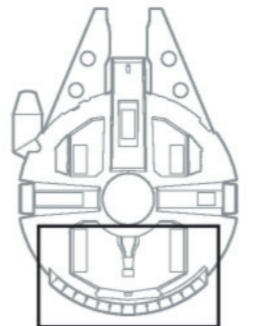

22

8X * 

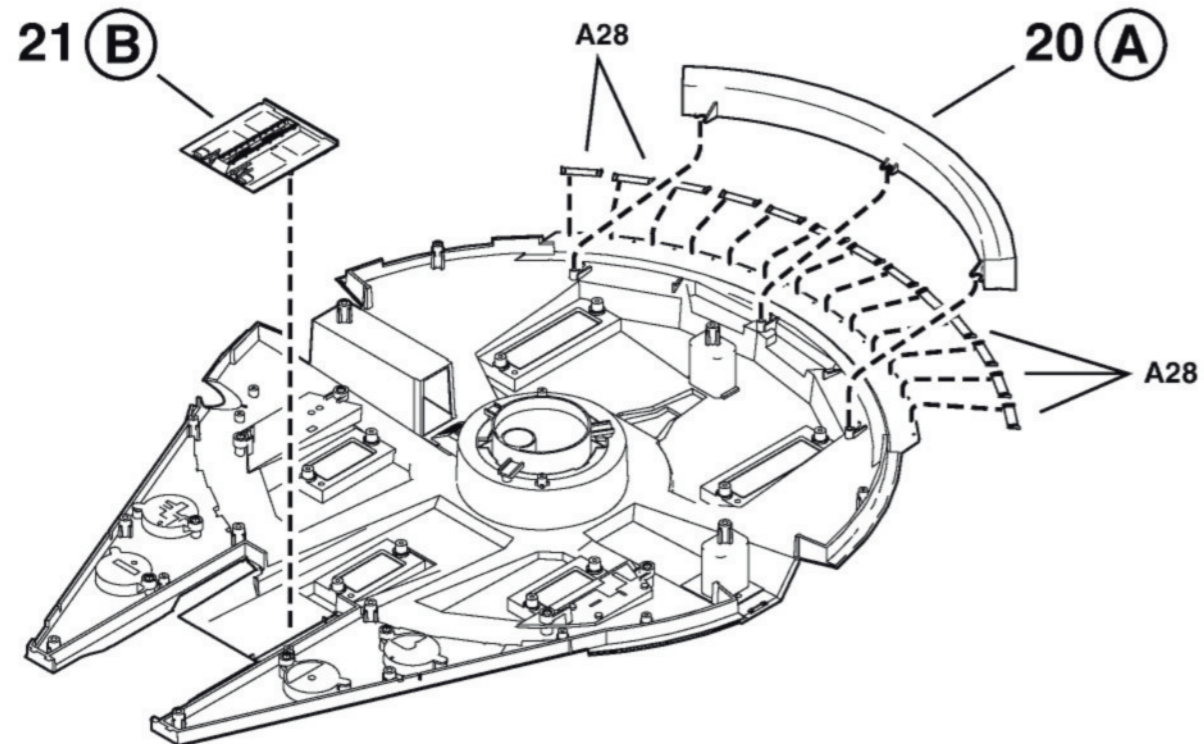
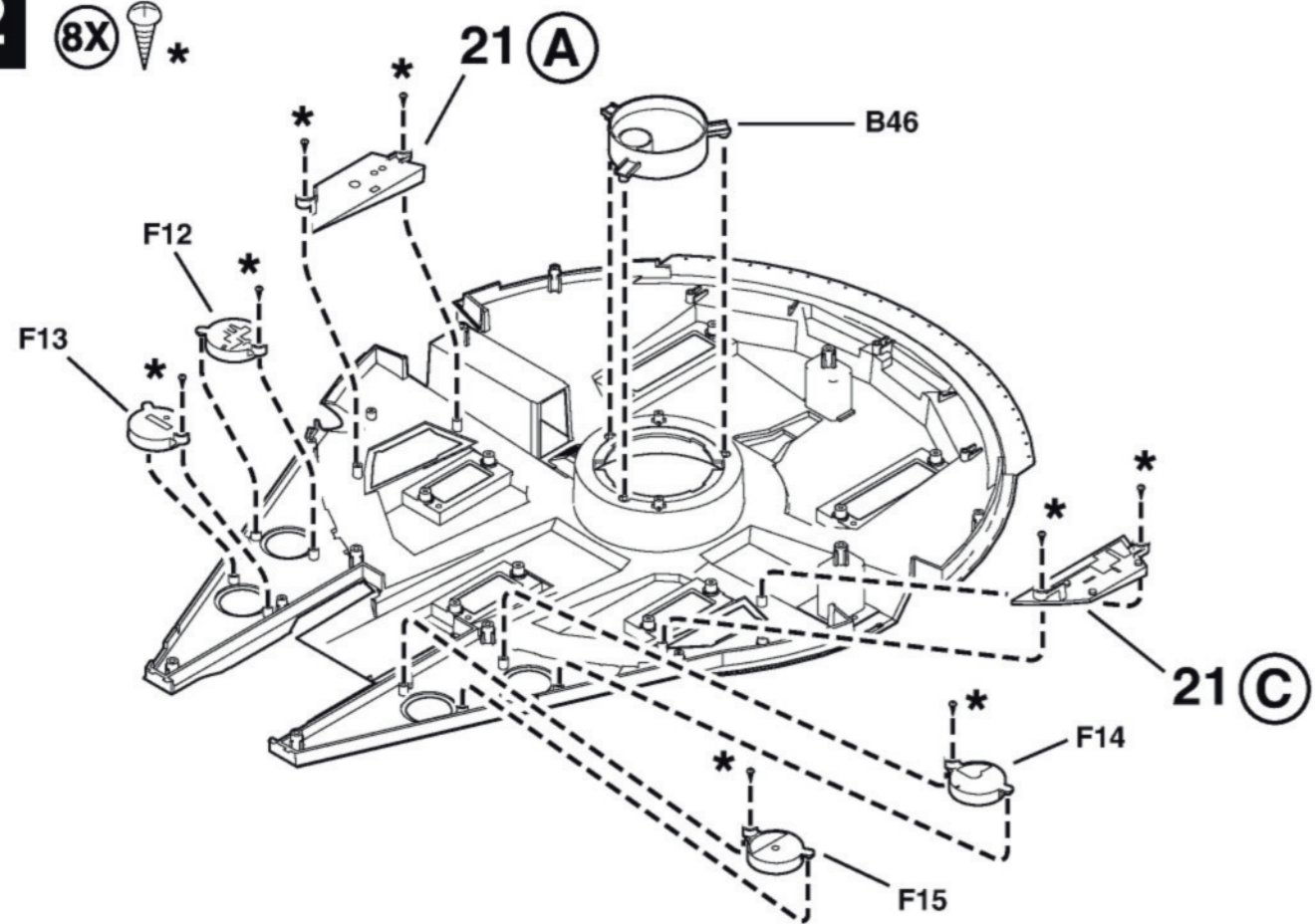

15

UPPER HULL

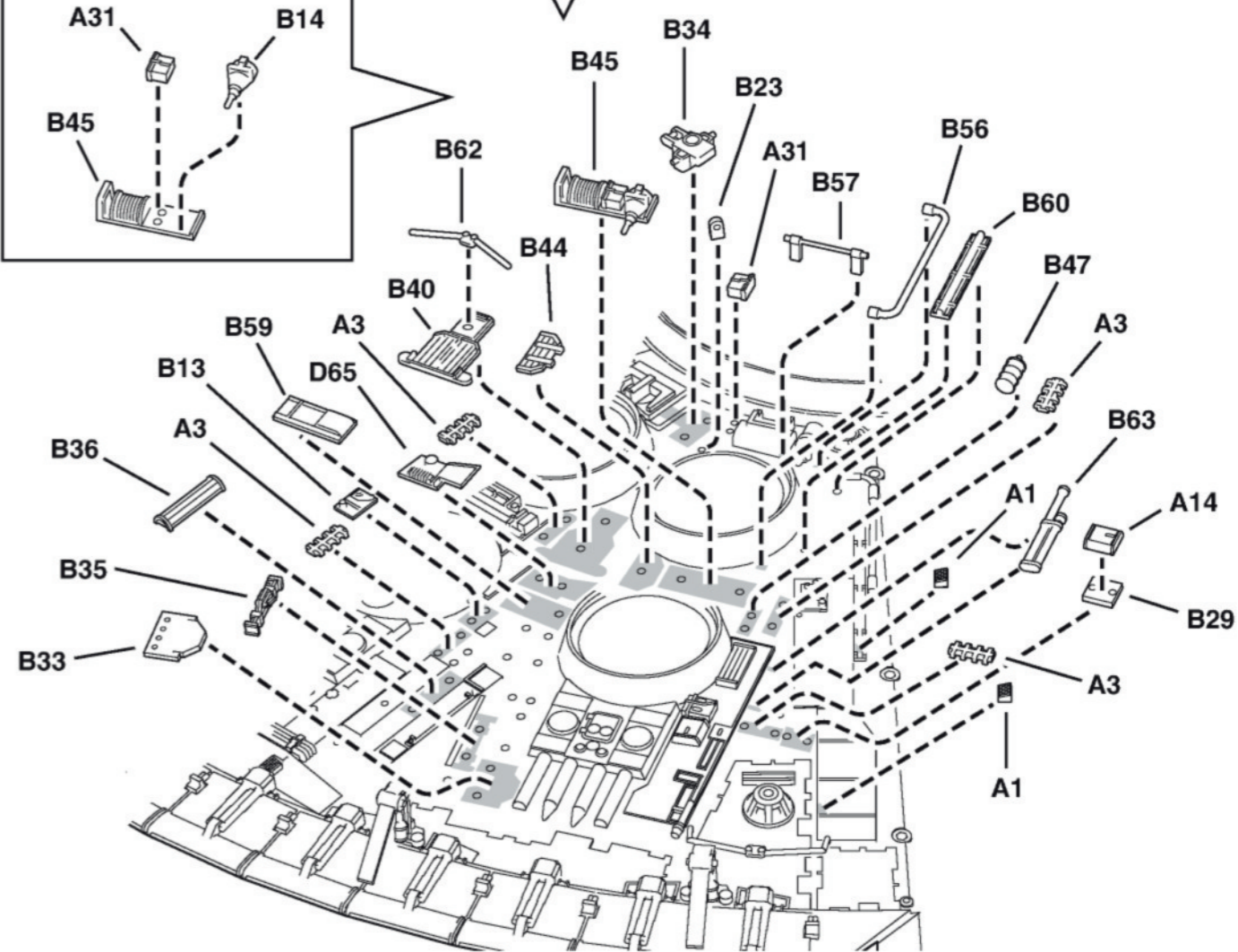
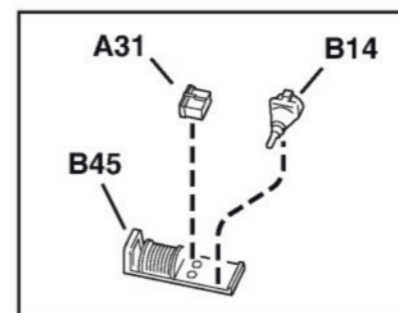
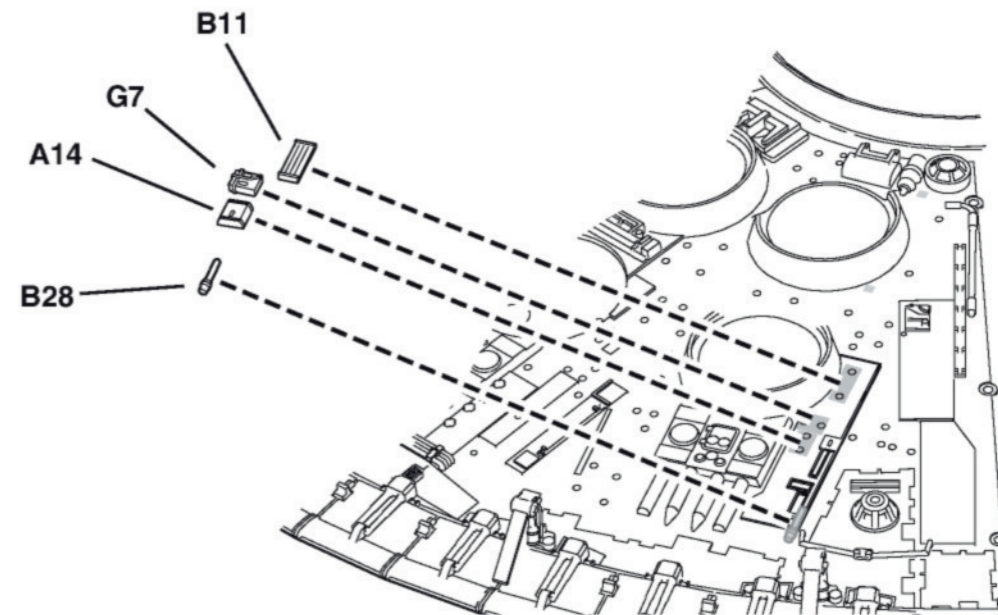
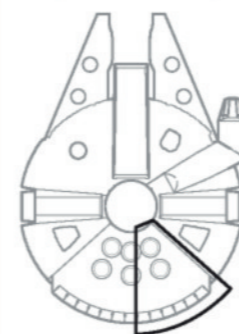

16

(A)

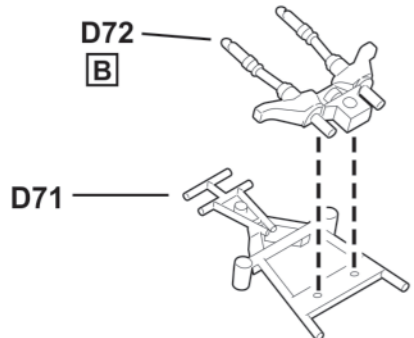

(B)

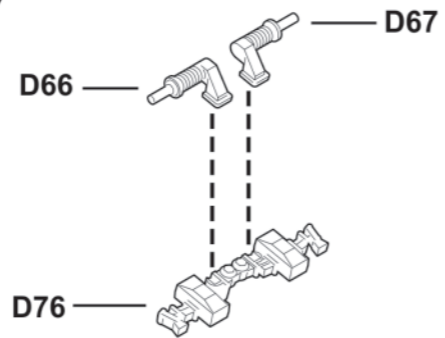

UPPER HULL

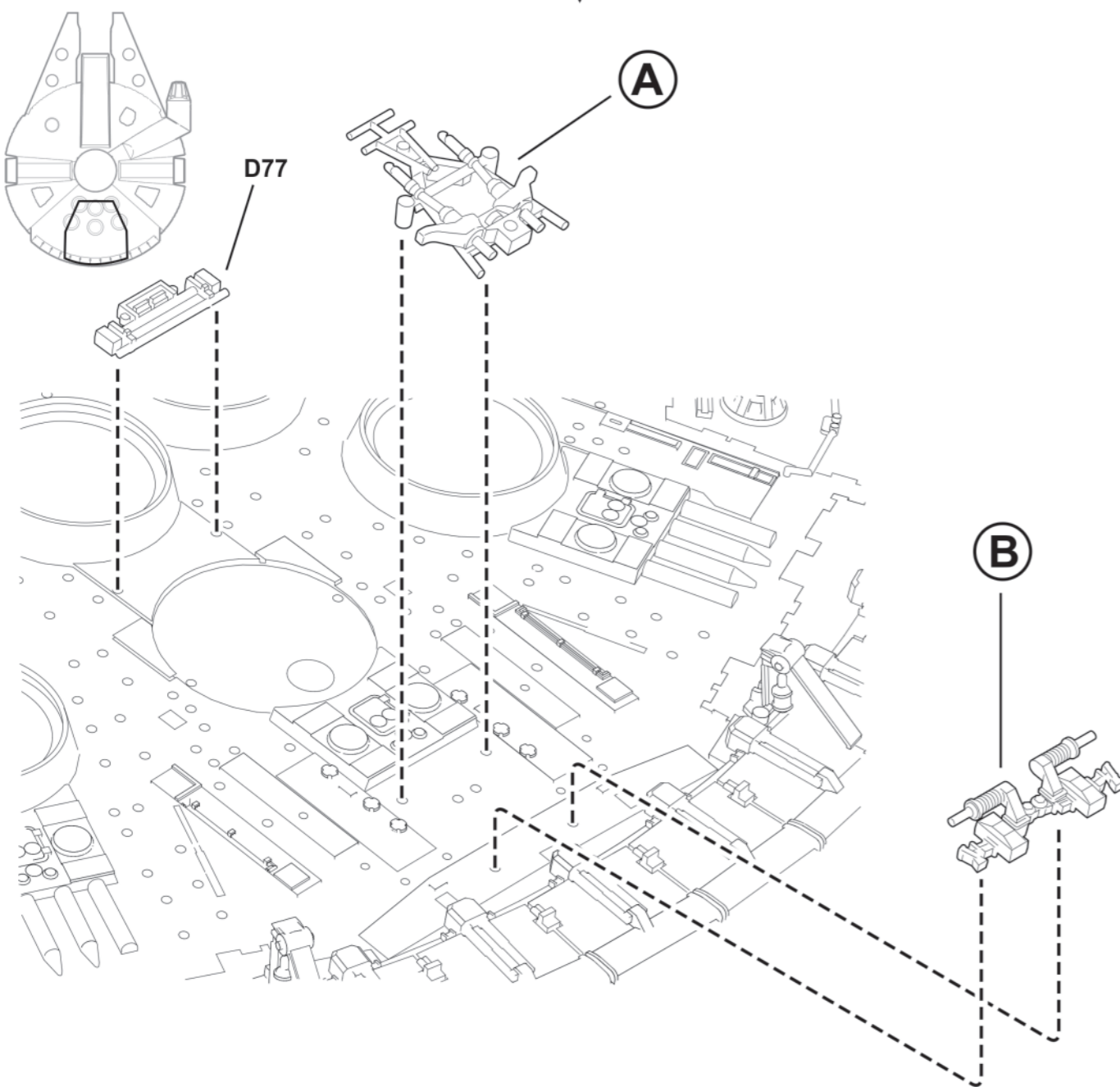

21

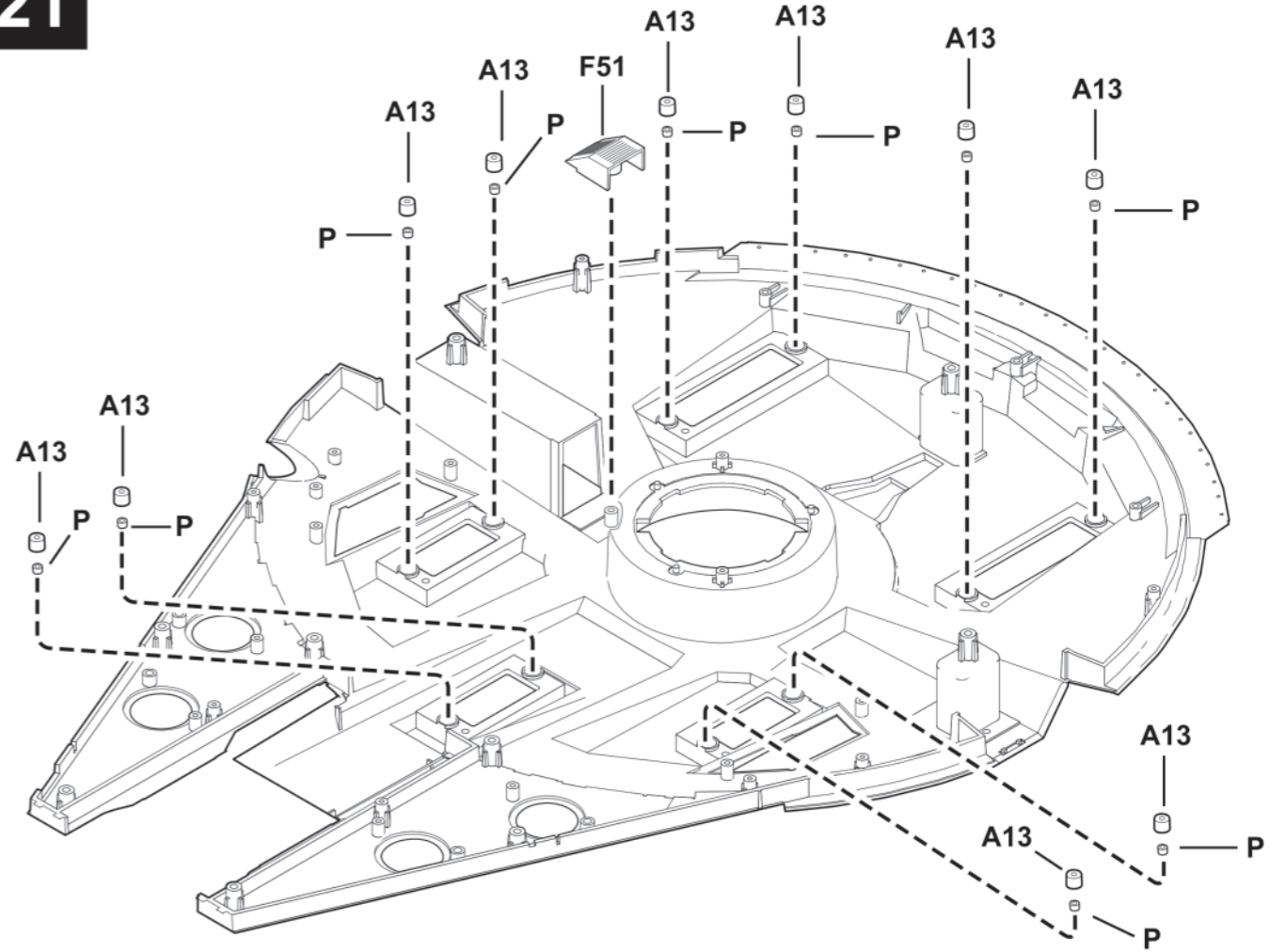

(A)

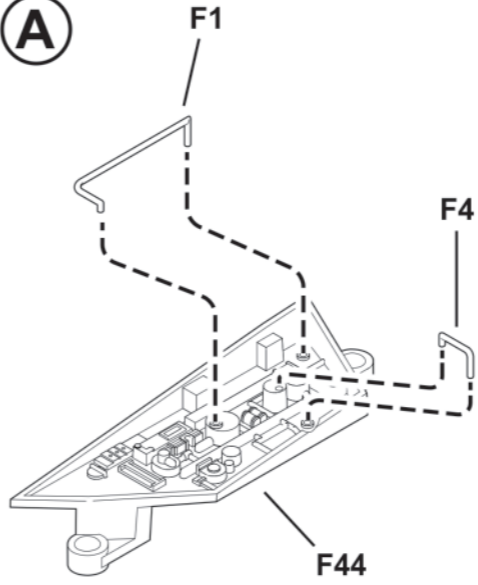

(B)

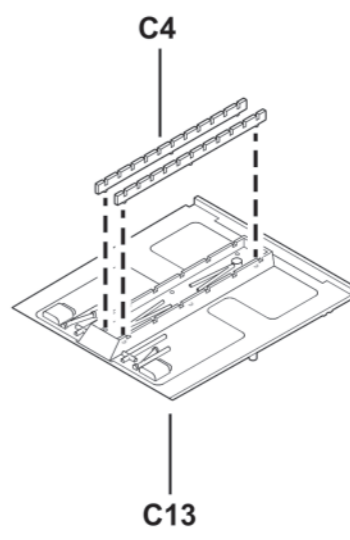

(C)

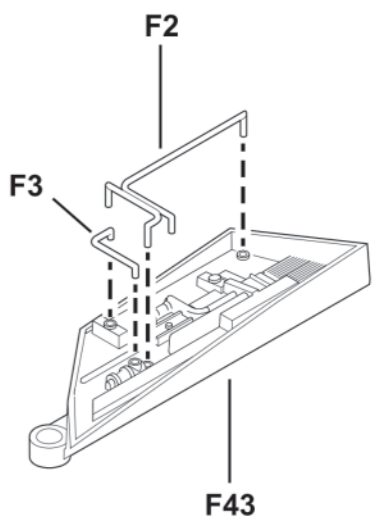

20

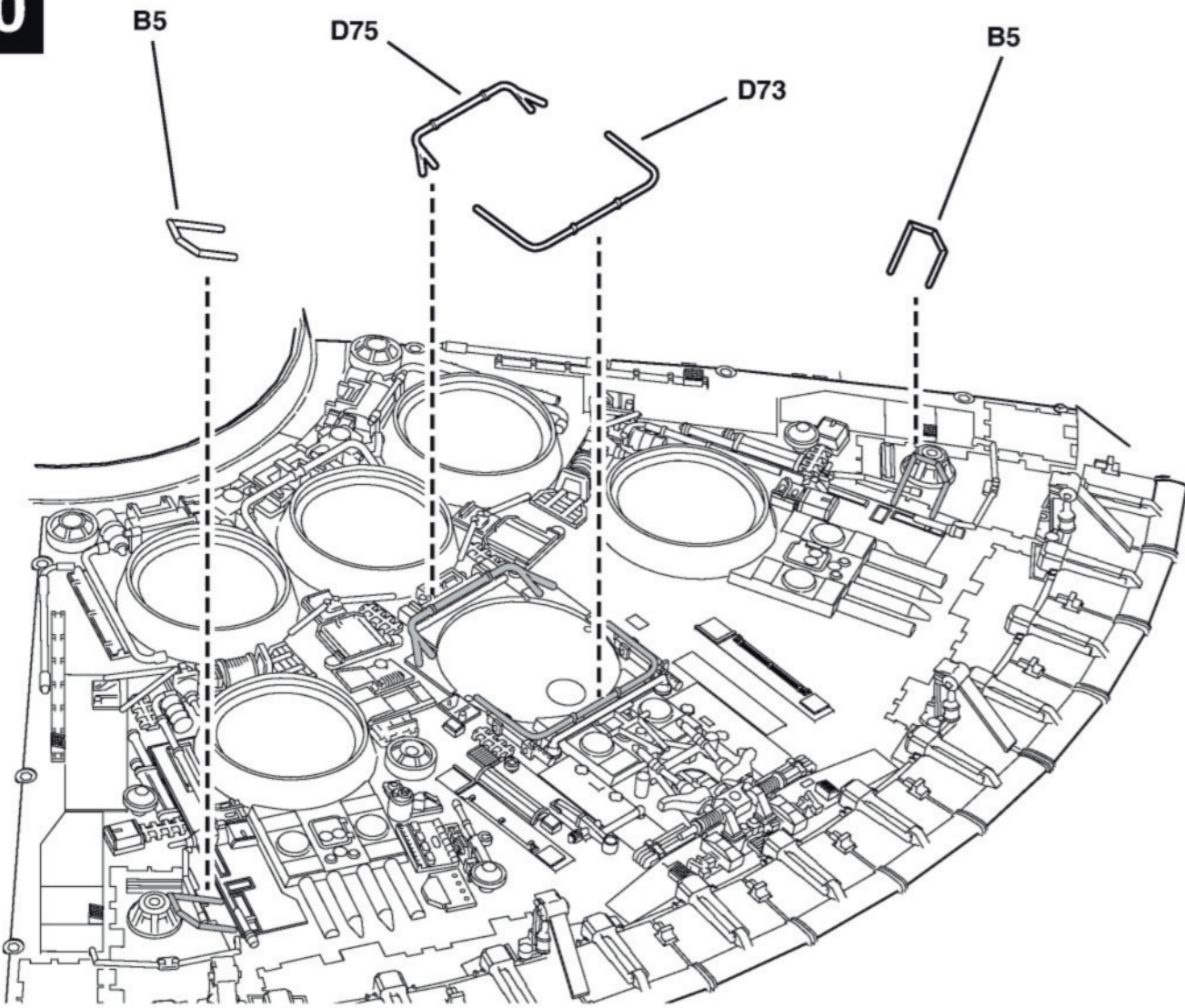

A

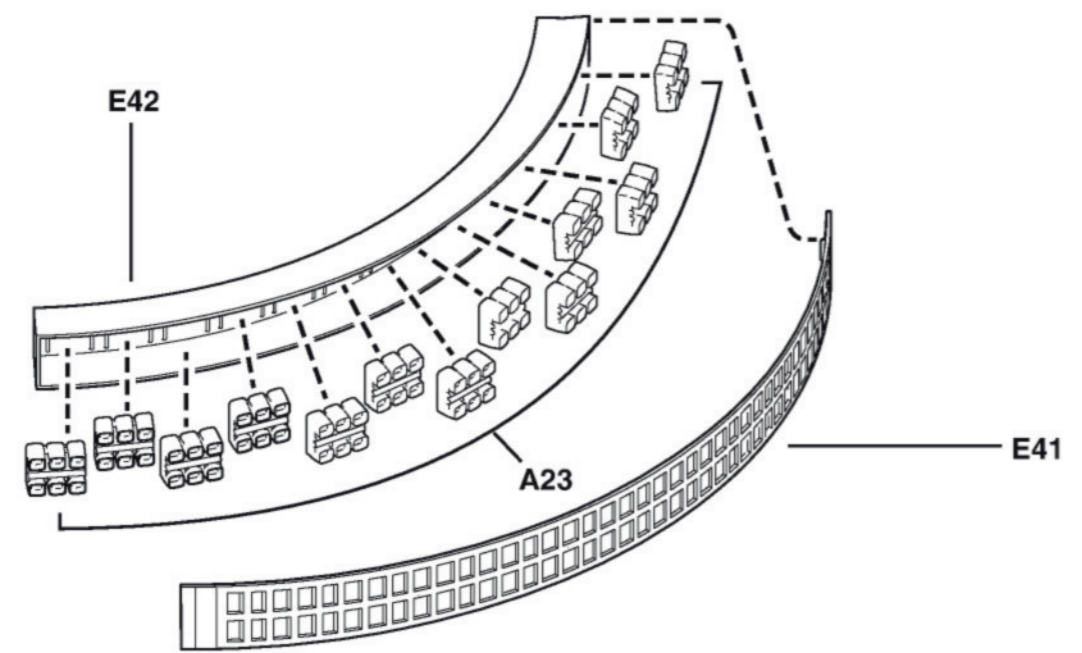

17

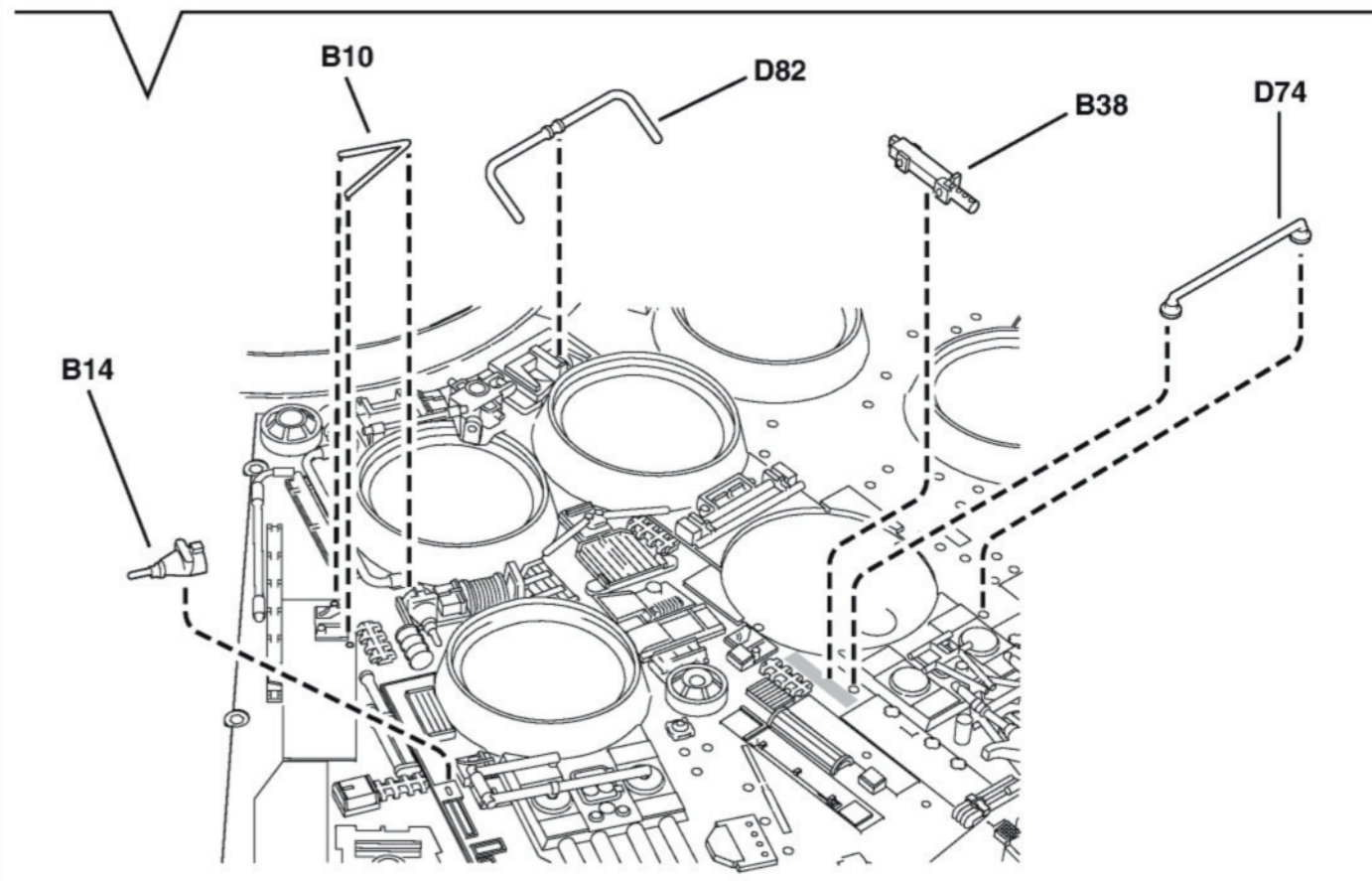
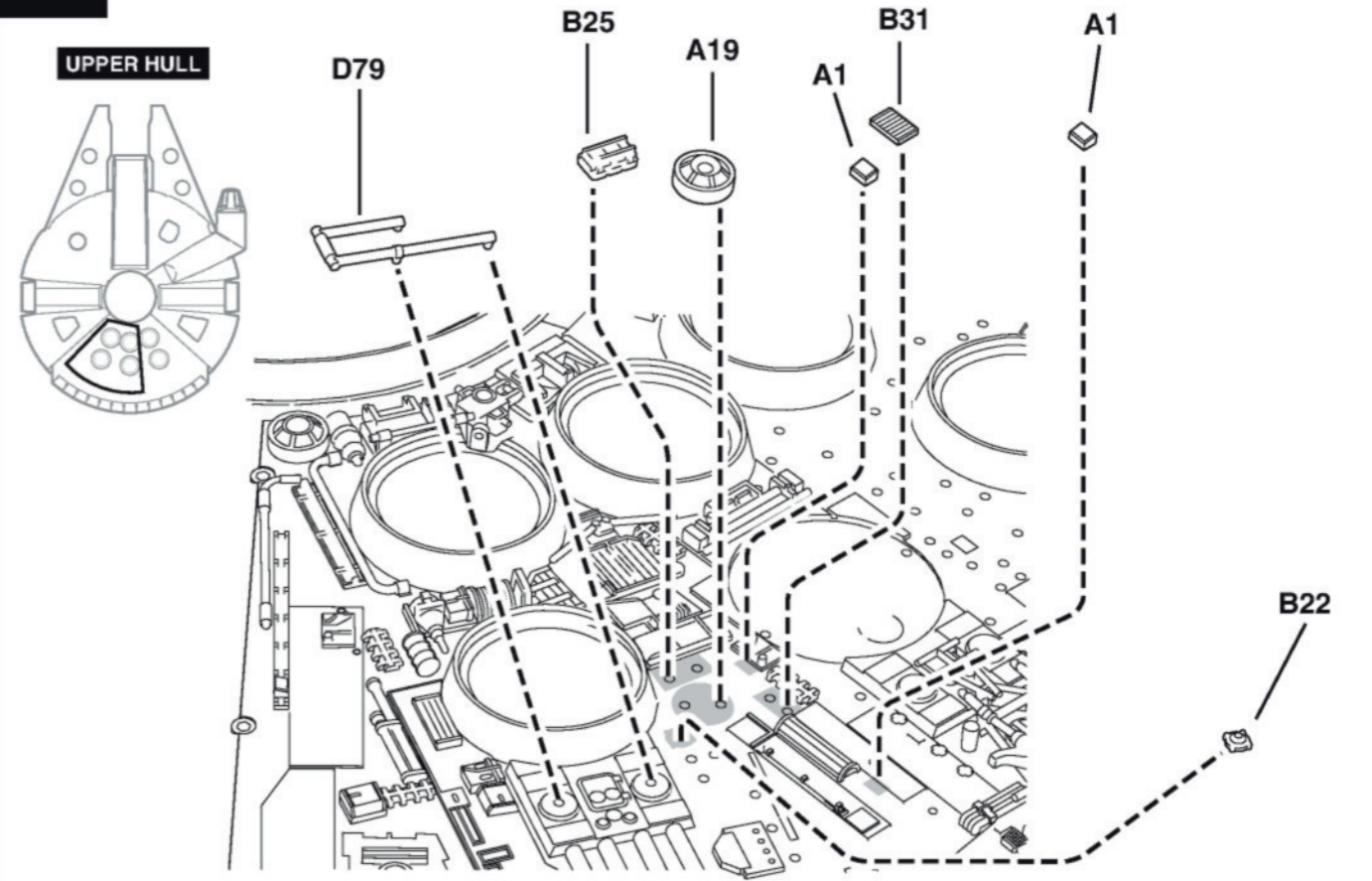

18

UPPER HULL

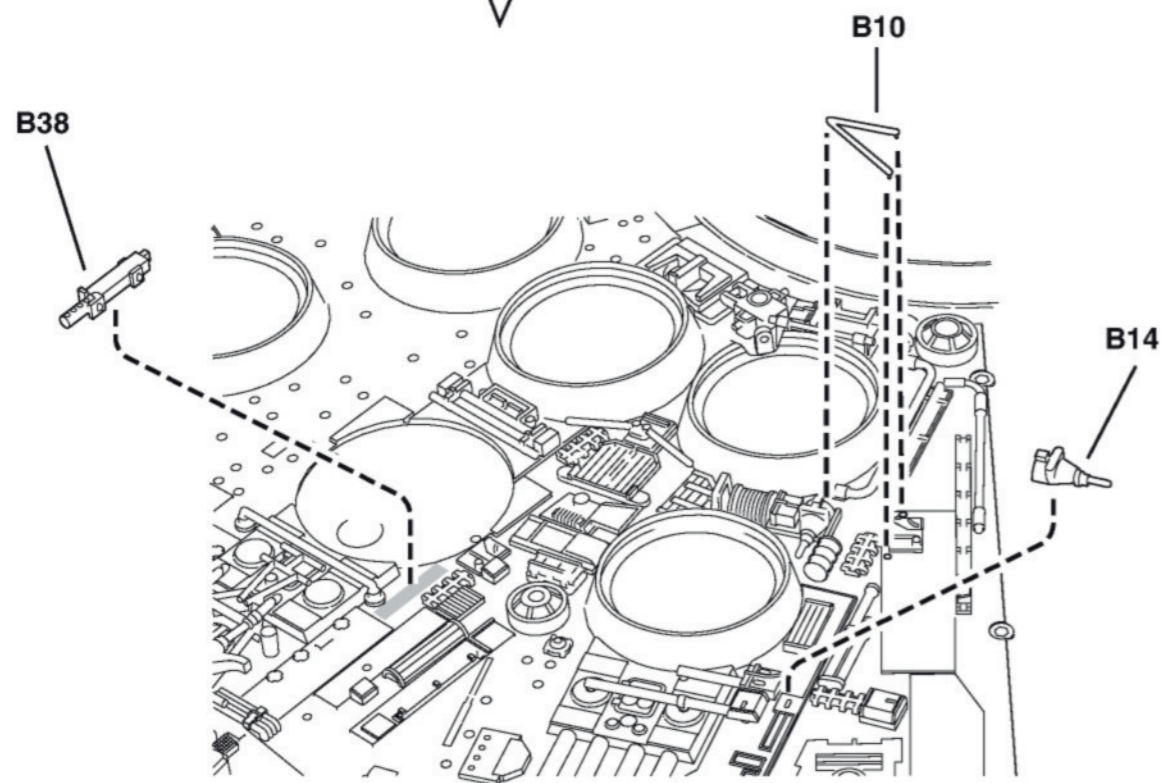
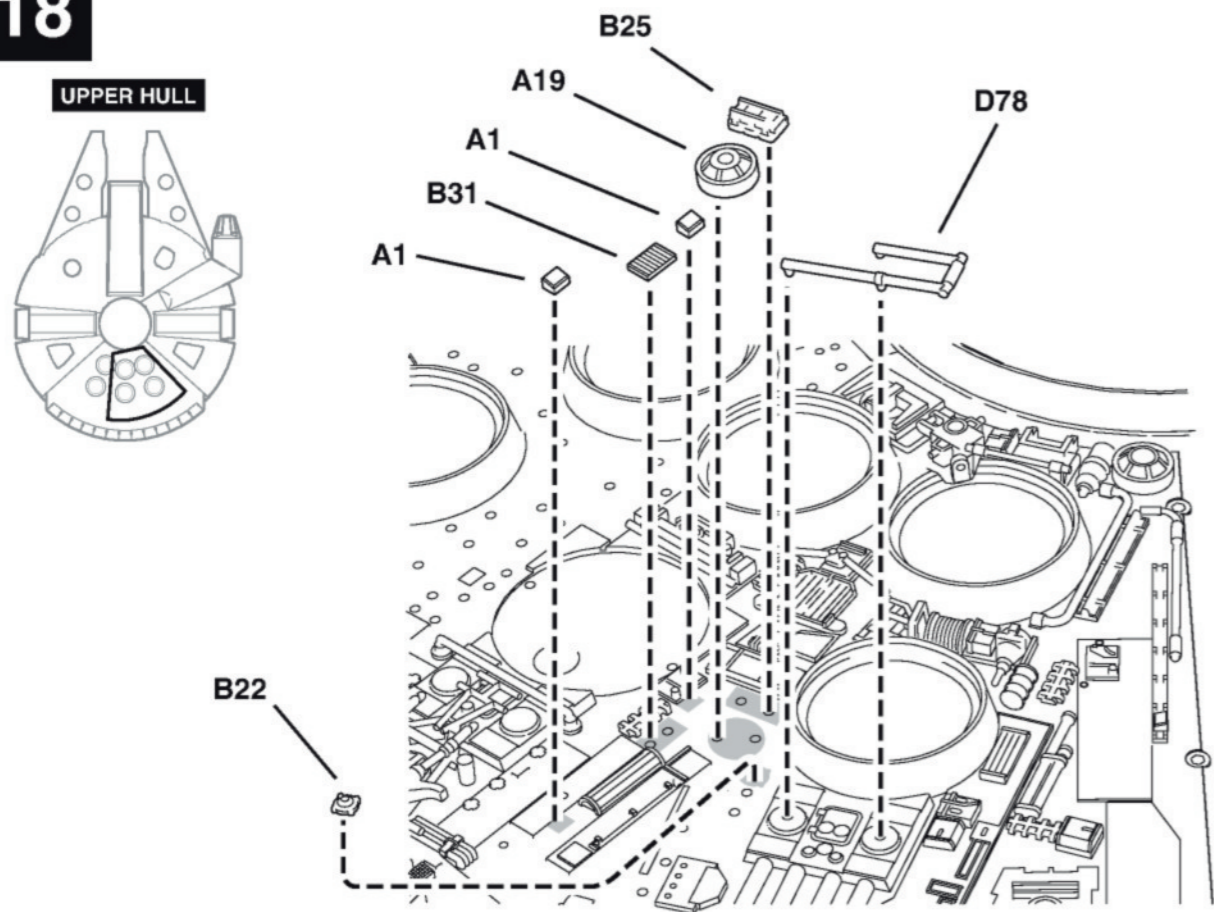

19

UPPER HULL

