

MULTIPLEX®

PROFI TX



Operating Instructions

Version 2.11

MULTIPLEX Modellsport GmbH & Co.KG • Westliche Gewerbestraße 1 • Bretten • Germany

©MULTIPLEX 2014 • Printed in Germany

www.multiplex-rc.de

Contents

Contents	0
1 Introduction	7
1.1 Concept of the PROFI TX	7
1.2 V2 software	9
1.2.1 Update from V1 to V2	9
1.2.2 New features in V2	9
1.2.2.1 Speech output	9
1.2.2.2 Volume	10
1.2.2.3 MagicSwitch	10
1.2.2.4 Switching thresholds	10
1.2.2.5 Timer	10
1.3 Contact	10
1.4 About these operating instructions	11
1.5 Basic safety instructions	13
1.6 Safety instructions for the transmitter battery	15
1.7 ESD notes for electronic sub-assemblies	16
1.8 Intended use	17
1.9 Liability and indemnification	20
1.10 Warranty	21
1.11 EC declaration of conformity	21
1.12 Disposal	22
2 Transmitter	23
2.1 Transmitter overview	23
2.1.1 Top view	23
2.1.2 Underside view	26
2.1.3 Carry handle / bars	27
2.1.3.1 Carry handle	27
2.1.3.2 Carry bars	27
2.1.4 The interior	28
2.1.5 Connectors	29
2.2 Initial setup	30
2.3 Mechanical operations on the transmitter	31

2.3.1	Opening and closing the case	31
2.3.2	Adjusting stick units	33
2.3.2.1	Swivelling stick units.....	33
2.3.2.2	Adjusting ratchet, friction and centring force	34
2.3.3	Installing stick tops with a switch or button.....	35
2.3.4	Installing additional controls	36
2.3.5	Installing additional modules	39
2.4	Transmitter battery.....	40
2.4.1	Charging the battery	40
2.4.1.1	Charging via the PC	41
2.4.1.2	Charging the battery using the plug-in charger	42
2.4.2	Removing the battery	42
2.4.3	Inserting the battery.....	42
2.4.4	Battery management	43
2.5	Switching the transmitter on / off	44
2.5.1	Switching on	44
2.5.2	Switching off.....	45
2.6	Range check.....	46
2.7	Trainer mode	49
2.8	Digital trim	50
2.8.1	Overview.....	50
2.8.2	Trim buttons.....	51
2.8.3	On-screen trim display	51
2.9	microSD card	53
2.9.1	Replacing the microSD card.....	53
2.9.2	microSD card from a different transmitter	53
2.9.3	New microSD card	53
2.9.3.1	Directory structure on the microSD card	54
3	Model templates	55
3.1	Templates for fixed-wing models	56
3.1.1	BASIC model template	58
3.1.2	ACRO model template	61
3.1.3	GLIDER+ model template.....	64
3.1.4	DELTA WING model template	67

3.1.5	FLYING WING model template	69
3.1.6	BIG SCALE model template	71
3.2	Templates for helicopter models	73
3.2.1	FUNCOPTER model template	75
3.2.2	eHeli FBL model template	76
3.2.3	eHeliccpm model template.....	77
3.2.4	HELiccpm model template.....	78
3.2.5	HELImech. model template.....	79
3.3	Templates for land- or water-based models and tracked vehicles	80
3.3.1	CAR / TRUCK model template.....	80
3.3.2	SHIP / BOAT model template	82
3.3.3	TRACKED V. model template.....	84
4	The menus	87
4.1	Status displays	87
4.1.1	Status display #1	87
4.1.2	Status display #2	88
4.1.2.1	Battery status	88
4.1.3	Status display #3	91
4.1.4	Status displays #4 to #8.....	92
4.2	Menu structure	93
4.3	Setup main menu	94
4.3.1	Volume.....	95
4.3.2	M-LINK.....	96
4.3.3	Flight phases.....	97
4.3.4	Training (principle)	99
4.3.4.1	Student mode.....	99
4.3.4.2	Teacher mode	100
4.3.5	Sensors	102
4.3.5.1	Vario. & Altitude	102
4.3.5.2	Announce & Alert	103
4.3.5.3	Edit name	104
4.3.6	Assign.Controls.....	104
4.3.7	Assign.Switches	106
4.3.7.1	TriggerPoint.....	107

- 4.3.7.2 MagicSwitch 108
- 4.3.7.3 Switch 109
- 4.3.8 Define mixer 110
 - 4.3.8.1 Name 110
 - 4.3.8.2 Mixer inputs 110
- 4.3.9 Transmitter 114
 - 4.3.9.1 Sounds 114
 - 4.3.9.2 Battery alarm 114
 - 4.3.9.3 Contrast 115
 - 4.3.9.4 Trim graph 115
 - 4.3.9.5 Menu direction 115
- 4.3.10 User data 116
 - 4.3.10.1 PIN 116
 - 4.3.10.2 Language 116
 - 4.3.10.3 Name 117
- 4.4 ControlFunctions main menu 118
 - 4.4.1 Aileron, Elevator, Rudder 121
 - 4.4.2 Throttle (fixed-wing models, vehicles, boats, and funcopters) .. 123
 - 4.4.3 Throttle (helicopter) 124
 - 4.4.3.1 Throttle curves (Governor OFF) 125
 - 4.4.4 Spoiler, Flap, Retract.Gear, Speed, Aux-1 to Aux-4 127
 - 4.4.5 Gyro 128
 - 4.4.6 Collective (only helicopters) 131
 - 4.4.7 Thr.Limiter (only helicopters) 131
- 4.5 Mixer main menu 132
 - 4.5.1 Fixed-wing models 132
 - 4.5.1.1 Combi-Switch 132
 - 4.5.1.2 Differnt.Ail 133
 - 4.5.1.3 Control mixers (Ctrl.Mix) 134
 - 4.5.1.4 Mixers on the servo side 136
 - 4.5.2 Helicopter models 138
 - 4.5.2.1 TAIL ROTOR 138
 - 4.5.2.2 MAINROTOR 139
 - 4.5.2.3 Control mixers (Ctrl.Mix) 144

4.5.2.4	Mixers on the servo side	144
4.6	Servo main menu	145
4.6.1	Calibrate	146
4.6.2	Assign	149
4.6.3	Monitor	150
4.6.4	Test run	151
4.7	Timer main menu	152
4.7.1	Model uptime count	153
4.7.2	Timer 1 to timer 3	153
4.7.3	Set Alarm Clock	155
4.7.4	Date & Time	156
4.8	Memory main menu	157
4.8.1	Select.....	158
4.8.2	Copy	158
4.8.3	New model	159
4.8.4	Edit name.....	161
4.8.5	Erase	162
4.8.6	Safety check	162
4.9	Error messages	163
5	Operating the transmitter	164
5.1	Operation using the keypad	164
5.1.1	Menu buttons	164
5.1.2	Buttons for special functions	165
5.1.3	Text input	166
5.2	Operation using the wheel.....	167
5.3	Digi-adjuster	168
5.3.1	Allocating a set value	168
5.3.2	Setting a value	169
5.3.3	Erasing the allocation.....	169
5.4	Assigning controls to control functions	170
5.4.1	Assign.Controls.....	170
5.4.2	Assign.Switches	173
6	Operating the transmitter using the PC	176
6.1	Connecting the transmitter	176

6.2	Editing model memories	177
6.3	Software update.....	178
6.4	Switching to normal mode	178
6.5	Model flying simulator	179
6.5.1	Via USB cable	180
6.5.2	Using the MULTIFlight stick	181
6.5.3	MULTIFlight simulator	181
7	Creating and customising models	182
7.1	Fixed-wing models	182
7.1.1	The procedure in principle	182
7.1.2	Creating a new model in the transmitter	182
7.1.3	Adjusting rotation direction and maximum travels for the servos / control surfaces.....	184
7.1.3.1	Configuring aileron differential	184
7.1.3.2	Adjusting control surface travel and maximum servo travel..	184
7.1.3.3	Adjusting elevators	186
7.1.3.4	Adjusting rudders	187
7.1.3.5	Adjusting flaps	187
7.1.3.6	Adjusting the power system	187
7.1.4	Using ailerons as spoilers.....	187
7.1.5	Using camber-changing flaps as spoilers	188
7.1.6	Optimisation.....	188
7.2	Helicopter models.....	190
7.2.1	The procedure in principle	190
7.2.2	Creating a new model in the transmitter.....	190
7.2.3	Preparing controls and switches	193
7.2.4	Checking and changing servo assignment.....	194
7.2.5	Checking and adjusting the main rotor	195
7.2.5.1	Checking / changing direction of servo rotation on the main rotor	195
7.2.5.2	Calibrating servos: setting centre and maximum travel	196
7.2.6	Checking and adjusting the tail rotor	199
7.2.6.1	Checking / changing the direction of servo rotation for the tail rotor	199
7.2.6.2	TAIL ROTOR mixer.....	199

7.2.7	Gyro	201
7.2.7.1	Setting gyro suppression	202
7.2.8	Throttle	203
7.2.9	Setting the collective pitch curve	204
7.2.10	Working with flight phases	205
7.2.10.1	Defaults in the Flight phases menu	205
7.2.10.2	Assigning switches for flight phases	206
7.2.10.3	Disabling / enabling flight phases	206
7.2.10.4	Copying flight phases	207
7.2.10.5	Changing flight phase names	207
7.2.10.6	Setting the transition time	208
8	Speech output & sounds	209
8.1	Volume	209
8.2	During startup	209
8.3	Battery monitor	209
8.4	Announcing trim	209
8.5	Announcing flight phases	209
8.6	Announcing sensor values	209
8.7	Announcing altitude	210
8.8	Other announcements	211
8.8.1	Teacher / student	211
8.8.2	Safety check	211
9	Maintenance and care	211
10	Appendix	212
10.1	Specifications	212
10.2	Accessories	213
	Glossary of technical terms	215
	Index	221

1 Introduction

We are pleased that you have decided to purchase the **PROFI TX** radio control system.

The new **PROFI TX** tray-type transmitter offers numerous innovative and pioneering features:

- Integrated aerial technology (IOAT)
- Secure, ultra-fast signal transmission
- Clean, clearly arranged menu structure
- Operationally secure LiFePo4 battery with battery management
- 30h operating time with one battery charge

Prior to initial setup, please read these operating instructions and observe all safety instructions.

1.1 Concept of the PROFI TX

When we initially mapped out the basic philosophy of the **PROFI TX**, we placed particular emphasis on providing a high level of user-friendliness, flexibility and the greatest possible standardization.

User-friendliness is achieved thanks to the clean overall menu structure, informative and clearly arranged menus and many other useful features which facilitate programming and operating the transmitter.

Flexibility is guaranteed because you can implement almost any customisations to the configuration for controlling a model. Controls, mixers and servos can be assigned freely. Pre-defined mixers can also be customised as required.

Thanks to model templates, you need to press only a few buttons to store your model in the memory and start operating it.

Special features

- Speech output in multiple languages
- Digital trim system
 - Clear visualisation of the trim positions that are specific to each flight phase on the screen
 - Audible support
 - Variable trim increments
- Battery monitor with announcement of remaining operating time (time to empty)

- Battery management system
 - Transmitter battery monitor with display of residual charge
 - Calculated display of remaining operating time (time to empty) in hours
- Servo monitor with graphical or numerical display for checking settings without the model
- Code lock with PIN (4-digit) for protecting the transmitter against unauthorised data access
- Modern, ergonomically efficient case design with ultra-precise, customisable, swivelling ball-raced stick units
- Graphics screen with high contrast
- Modern FLASH processor technology (software updates can be downloaded from the Internet)
- Wireless, selective trainer mode
- Clearly designed, efficiently structured menus for simple programming
- Quick operation thanks to menu buttons and central wheel
- Unique Quick-Select assignment of control functions to teacher and student
- Clear text menu system, screen texts can be displayed in various languages
- Announcement of altitude and other sensor values
- Variometer tone, sink rate configurable
- 4 flight phases with configurable transition time Additional flight phases via mixers.
- 4 mixers on the control side (usage varies between model templates)
- 7 mixers on the servo side with 8 inputs each and 12 mix options per input
- Servo calibration using 2 to 5 points for compensation of mechanical discrepancies
- 3 universal timers: Selectable basic function: frame, sum, or interval. Configurable alarm time, 10 time markers for audible alarms, counter or count down mode
- 2 timers for model and transmitter operating time.
- Convenient model memory management
 - Free-text model names, up to 18 characters
 - Copy and erase functions
 - Model templates for creating new models.

Differences between transmitter versions

	PROFI TX 9	PROFI TX 12	PROFI TX 16
Channels	9	12	16
Model memories	50	100	200
Other			Volume control using mixers

1.2 V2 software

1.2.1 Update from V1 to V2

Additional files must be installed when updating from software version 1 to version 2. Refer to section 6.3 "Software update" on page 178 for details.

In version 2.xx, the volume settings are stored in the model memory. The volume is set to 16 by default for newly created model memories. This setting is not available in older model memories: The volume is initially set to OFF. You can configure the desired volume level in the Setup > Volume menu.

1.2.2 New features in V2

1.2.2.1 Speech output

The following information can be output as speech:

- remaining operating time (time to empty; in minutes) for the transmitter
- flight phase
- status of the teacher / student connection
- trim position
- time markers of the timers
- announcement of the altitude
- announcement of selected sensor channels
- sensor value when a sensor alarm is issued
- announcement of the time of day by the alarm clock

Sound and speech output can be customised. Details will be made available in the Downloads section of our home page by the 3rd quarter 2014.

1.2.2.2 Volume

- The volume can be set by either choosing a fixed value or by configuring freely assignable controls. We recommend using rotary potentiometers that are installed on the front (Item No.: 75756).
- The variometer volume is configured separately.
- With the PROFI TX 16, the volume can also be controlled via mixers.
- The volume control data is stored in the model memory.

1.2.2.3 MagicSwitch

- The number of MagicSwitches was doubled from 2 to 4.
- Each MagicSwitch now has an additional OR input.

1.2.2.4 Switching thresholds

The switching thresholds of controls that are installed on the front were changed from 50% to 95% (rotary potentiometers are used as switches).

1.2.2.5 Timer

The specialised timers were replaced by universal timers.

- Three operating modes are available for each timer: frame, sum, and interval
- The counting mode can be selected: Up or Count down
- You can select to have the time announced within 5 minutes before an alarm occurs or the zero point is passed.
- The timers can be renamed as desired.

1.3 Contact

Should you still have any questions regarding your **PROFI TX**, please feel free to contact your specialist dealer who will be happy to assist you.

Service partners

The addresses of our service partners are available on our website:

www.multiplex-rc.de

1.4 About these operating instructions

These operating instructions describe the **PROFI TX** tray-type transmitter and contain the following sections:

- **Section 1 "Introduction"** provides an overview of the **PROFI TX** concept and information regarding the current firmware version.
- **Section "Safety instructions"** contains important information concerning safety, intended use and warranty.
- **Section 2 "Transmitter"** describes:
 - The **PROFI TX** hardware.
 - How to setup the transmitter for operation.
 - Mechanical operations that may have to be carried out on the transmitter, e.g. installing additional controls.
 - How to charge the transmitter battery including battery management.
 - How to switch the transmitter on and off.
 - How to perform a range check and the binding procedure.
 - How to operate in trainer mode.
 - How to trim your model aircraft.
- **Section 3 "Model templates"** describes the model templates available in the **PROFI TX**.
- **Section 4 "The menus"** describes the **PROFI TX** software:
 - Navigation within the software.
 - The status displays.
 - All menus and their parameters.
- **Section 5 "Operating the transmitter"** describes:
 - How to operate the transmitter by means of the keypad, the central wheel and, if necessary, the optional digi-adjusters.
 - How to assign controls and switches. This defines which controls are used to operate the various functions in the transmitter or model.
- **Section 6 "Operating the transmitter using the PC"** describes how to connect the transmitter to the PC and the options provided by this connection.
- **Section 7 "Creating and customising models"** describes step by step using two examples how to create and configure your own fixed-wing and helicopter models.

- **Section 8 "Speech output & sounds"** contains detailed information on speech output and sound files.
- **Section 9 "Safety instructions"**

Make sure to read and observe the following operating and safety instructions!

Knowledge of these operating instructions and their observance are a prerequisite for safe use as well as safe operation and maintenance.

The following basic safety instructions and warnings are an essential component of these operating instructions and are fundamentally important for product handling.

Keep the operating instructions at hand and pass them on to the new owner on resale of the product.

Failure to observe the safety instructions can result in property damage, injuries or even death.

Signal words and their meaning



DANGER identifies an immediate possible dangerous situation with a high risk that will result in death or severe personal injury if not avoided.



WARNING identifies a possible dangerous situation with a medium risk that may result in death or (severe) personal injury if not avoided.



CAUTION identifies a possible dangerous situation with a low risk that might result in minor or moderate personal injury if not avoided.



NOTICE indicates the possibility of misuse which could cause damage to the product.



INFORMATION that is important for the **PROFI TX** operator.

1.5 Basic safety instructions

The following basic safety instructions and warnings are an essential component of these operating instructions and are fundamentally important for device handling.

NOTICE**Read the instructions carefully!**

Make sure that you have carefully read these operating instructions and the following safety instructions before setting up the device for operation.

⚠ WARNING

Radio-controlled models are not toys in the usual sense. Assembly, installation, and operation of the RC system require technical knowledge, care, safety-awareness and responsibility. Errors or negligence can lead to considerable damage. Since the manufacturer or the seller does not have any influence and control over the proper setting up and operation of a model, such risks are expressly pointed out here and any liability whatsoever is excluded.

A model that goes out of control for whatever reasons can cause significant damage to property or personal injury. Be aware of safety at all times. Make sure to take out general liability insurance.

NOTICE

Do not modify the radio control system. Use only original accessories and spare parts.

NOTICE

If the device is operated in combination with third-party products, ascertain their quality and functional reliability. Each new or changed combination must undergo careful functional testing, including a range check. Do not operate the device or model if there appear to be any problems. First identify the error and troubleshoot it.

NOTICE

In particular, have the radio control transmitter and the receiver inspected at an authorised MULTIPLEX Service Centre (see section 10.1 "Specifications" on page 212) at regular intervals (every 2 to 3 years).

⚠ CAUTION

Operate the transmitter only in the permissible temperature range (see section 10.1 "Specifications" on page 212). Bear in mind that condensation may form in the transmitter due to sudden temperature changes (e.g. warm car, cold environment).

Moisture may impair the function of the transmitter and other components of the radio control system.

If moisture accumulates in electrical devices, immediately stop using the device, disconnect it from the power supply and allow it to dry in the open state as far as possible (up to a few days). Thereafter, perform a careful functional test. In case of major condensation, have the device inspected at an authorised MULTIPLEX Service Centre (see section "1.2" on page 9).



Operation of the radio control system is allowed without restrictions within EU territory and Switzerland.

NOTICE

Program a new model at home in peace. Make sure that the power system of the model cannot start up unexpectedly. Check all functions carefully. Completely familiarize yourself with the operation of the transmitter before putting the model in operation.

1.6 Safety instructions for the transmitter battery

NOTICE

The transmitter battery powers the device and plays an important role in operational safety. The charging circuit integrated in the transmitter matches the battery. Do not charge the battery outside the device.



Batteries are not toys: They must be stored out of the reach of children.

NOTICE

Damaged or defective batteries must not be used and should be disposed of properly (see section 1.12 "Disposal" on page 22).

⚠ WARNING

Do not heat, incinerate, open or short-circuit rechargeable batteries, do not charge or discharge them at excessive currents, do not overcharge them, avoid deep discharge, and do not charge with reversed polarity. Observe of the permissible temperature range for the battery.

⚠ WARNING

Mishandling the battery incurs the risk of combustion, explosion, chemical burns and fire.

1.7 ESD notes for electronic sub-assemblies



The sub-assemblies of radio control transmitters (main circuit board, modules) are fitted with electrostatically sensitive components. These parts can be destroyed, suffer imperceptible damage or have their useful life shortened if static discharges take place (potential equalisation through electro-static discharge) when the sub-assembly is touched.

The following protective measures are essential if you have to handle electrostatically sensitive sub-assemblies:

- Before fitting or removing such sub-assemblies, equalise the electrical potential difference between yourself and your environment (e.g. by touching a heating radiator).
- Open the basic device and touch it over a large area in order to equalise the potential relative to the base unit.
- Do not remove any sub-assemblies from their conductive anti-static bags until you have equalised the potential. Avoid touching electronic components or solder pads directly. Hold the sub-assembly by the edges of the circuit board only.
- Once removed from the basic device, the sub-assembly should only be stored in the conductive anti-static bag in which it was delivered. Never allow the sub-assembly to make direct contact with a conventional, non-ESD compatible container made of foam, Styrofoam or other plastic.

1.8 Intended use

The PROFI TX transmitter is intended exclusively for operation of models by radio control.

NOTICE

Always follow the switching on/off sequence in order to avoid any uncontrolled, dangerous startup of the power system:

Switching on sequence using the BEC:

1. Disconnect the BEC connector from the receiver.
2. Set the throttle on the transmitter to OFF, then switch on the transmitter.
3. Connect the power system battery.
4. Connect the BEC connector to the receiver.

Switching off sequence using the BEC:

1. Disconnect the power system battery.

Switching on sequence using the receiver battery:

1. Disconnect the power system battery.
2. Set the throttle on the transmitter to OFF, then switch on the transmitter.
3. Connect the receiver battery.
4. Connect the power system battery.

Switching off sequence using the receiver battery:

1. Disconnect the power system battery.
 2. Disconnect the receiver battery.
-

Assemble the model carefully

- Install and adjust all control surface linkages in such a way that the surfaces move smoothly and freely, and are not stalled even at maximum travel. Do not use the radio control to regularly limit servo travels. Preferable: Adjust control surface levers and pushrods mechanically and as thoroughly as possible. Avoid lost motion (sloppy linkages). Use configuration options on the servo side of the RC transmitter only for fine-tuning.

Observe the above-mentioned guidelines to make full use of the resolution (positioning accuracy) of your radio control system.

- Provide effective protection from vibration to the receiver, battery, servos and other RC and electronic components. Observe the advice included in the relevant operating instructions. Balance propellers and rotor blades before use and replace them at any sign of damage. Install I.C. engines on vibration-absorbing mounts and replace motors or motor parts which are damaged or do not run true.
- Do not strain or bend cables; protect them against rotating parts.
- Keep servo cables as short as possible.
- Use cables with sufficient cross-section.
- Do not coil up or shorten the receiver aerial. Do not lay the aerial on or close to electrically conductive components. Deploy aerials outside of fuselages with a shielding effect (carbon fibre, metallic painted finish).
- Ensure that the receiver power supply is of adequate capacity. For servos up to about 40Ncm torque you can estimate the required battery capacity using the following formula:
Capacity [mAh] ≥ number of servos x 200 mAh.
Use the next larger size of battery!
- Take care to maintain sufficient distance between cables carrying heavy currents (e.g. electric power system) and the RC system. Especially the cables between brushless electric motors and their actuators must be kept as short as possible (guide value: max. 10 to 15 cm).

Check the model regularly

- Free movement and zero backlash of control surfaces and linkages.
- Stability and flawless condition of pushrods, linkages, hinge joints, etc.
- Carry out a visual check for fractures, cracks, possible shear points etc. on the model itself, and in its components such as the RC and power systems.
- Flawless condition and contact stability of cables and plug connections.
- Absolutely essential: Examine the power supply and its wiring, including the switch harness, and the external condition of the battery.

This entails regular maintenance of the batteries and periodic checks of the voltage curve and capacity, employing a charge process and battery charger suitable for the type of battery in use.

Pre-flight checks

- Charge the transmitter, receiver and power system batteries carefully to full capacity, and verify their state of charge at regular intervals.
- Ensure that the correct model memory is active on the transmitter.
- Carry out a range check (see section 2.6 "Range check" on page 46).
- Check the function and effect of all primary and secondary control systems.

NOTICE

If you discover any irregularities, do not fly. Locate the problem, eliminate it, and then check again.

When operating the model:

- If you have never flown a radio-controlled model before, it is highly recommended you consult an experienced model pilot when getting started. A trainer (buddy-box) system is ideal for taking the first steps in learning to fly.
- Models should only be operated at suitable sites.
- Never fly or drive over or towards spectators.
- Do not carry out any high-risk flying or driving manoeuvres.
- Know your limits: do not over-estimate your abilities and skills.
- If you detect any sign of a problem or interference, land or cease operations immediately.

1.9 Liability and indemnification

The model sport with radio-controlled models is a fascinating hobby. However, model aeroplanes, vehicles and ships are not toys. Their assembly and operation require a high level of technical knowledge, careful craftsmanship, safety-awareness and responsibility. Errors, inattentiveness or even negligence can lead to considerable damage to property or severe personal injury. Generally, you as operator are responsible for any threat arising from your model. This absolute liability will not be assumed by the manufacturer. This is also applicable in the event of uncontrollable external influences and interferences. You are expected to exercise extreme care as operator of a model.

Since manufacturers or dealers cannot have any influence on proper setting up, maintenance and operation of the model and the radio control system, such risks are expressly pointed out here.

MULTIPLEX Modellsport GmbH & Co.KG does not assume any liability for loss, damage or costs which arise through the improper use and operation of our products, or which are connected with such operation in any way.

As far as is legally permissible, the obligation to provide compensation for damages, on whatever legal basis, is limited to the invoice amount of the quantity of MULTIPLEX goods that were directly affected by whatever incident gave rise to the damage. This does not apply if MULTIPLEX is obliged to accept unlimited liability in accordance with mandatory law for deliberate or gross negligence.

Furthermore, MULTIPLEX Modellsport GmbH & Co.KG does not extend any warranty for the completeness and correctness of the documents enclosed with the radio control components.



Observe also the advice included in the relevant transmitter documentation!

1.10 Warranty

Our products are covered by the statutory warranty regulations. If you wish to make a claim under warranty, please contact the model shop where you purchased the product.

The warranty does not cover defects and malfunctions caused by the following:

- improper operation, wrong connections, terminal reversal
- use of third-party components; modifications and repairs that were not carried out at an authorised MULTIPLEX Service Centre
- damages caused by the use of force
- defects due to improper use and / or normal wear and tear
- operation of the equipment outside the technical specifications



Observe the information leaflets included in the relevant transmitter documentation!

1.11 EC declaration of conformity

The **PROFI TX** devices were assessed in accordance with the relevant harmonised European directives.

You are therefore the owner of a product whose design fulfils the protective aims of the European Community relating to the safe operation of equipment.

The detailed declaration of conformity can be downloaded from our website:

www.multiplex-rc.de

under

[DOWNLOADS / Product Information](#)

If required, you may also send us your request for the declaration of conformity by post:

MULTIPLEX Modellsport GmbH & Co.KG

Customer Service

Westliche GewerbestraÙe 1

D-75015 Bretten-Gölshausen, Germany

1.12 Disposal



In the countries of the EU (European Union), electrical equipment must not be disposed of via the household or residual waste system. Waste equipment must be taken to your nearest local authority waste collection point or recycling centre.

There, equipment will be disposed of properly and free of charge.

Remove the batteries before disposing of the equipment. (Rechargeable) batteries are recycled separately.

By returning your waste equipment you can make an important contribution to protecting the environment.

Recycling of rechargeable batteries

Do not dispose of depleted rechargeable batteries in household waste.

Take them to a suitable recycling system. Rechargeable batteries must be discharged and short-circuit safe. Tape over the terminals with non-conducting adhesive tape.

2 Transmitter

2.1 Transmitter overview

2.1.1 Top view



Figure 1: Top view of the transmitter

- 1 Power button with annular light (see "Switching the transmitter on / off" on page 43).
The annular light indicates the status of the RF module during operation (see "Annular light" on page 24).
- 2 UV-stable, anti-glare graphic LCD unit (256 x 64 dots) featuring high contrast.
The screen contrast can be optimised (see section 4.3.9 "Transmitter" on page 114), and the screen can be raised as required.
- 3 Warning lights for the sensors used on the model. The warning lights indicate whether the alarm values for certain sensor groups have been exceeded (see section "Warning lights" on page 25).

- 4 Two ultra-low friction, ball-raced stick units for controlling the 4 primary control axes.
 - The stick ratchet for throttle / spoiler can be activated to the right or left (see section 2.3.2 "Adjusting stick units" on page 33).
 - Both stick units can be swivelled to suit the pilot's ergonomic preferences (see section 2.3.2.1 "Swivelling stick units" on page 33).

The stick tops can be rotated and freely adjusted in length, and are available in different variants.
- 5 Two slide potentiometers (controls <E and F>) with position markers for freely assignable channel and / or switched functions.
- 6 Buttons for digital trim of the 4 stick units (see section 2.8 "Digital trim" on page 50).
- 7 Central wheel for navigating through the menus and editing set values. The wheel can be turned in increments to the left or right and can be pressed (see section 5.2 "Operation using the wheel" on page 167).
- 8 Keypad, consisting of 11 buttons in 2 rows
 - The 6 buttons in the upper row are used for quick and direct access to the 6 main menus (see section 5.1.1 "Menu buttons" on page 164).
 - The 5 buttons in the second row are used for programming (see section 5.1.2 "Buttons for special functions" on page 165).
 - With the exception of the **ENTER** button, all the buttons have a dual function for text input. Text is entered in a similar way to mobile phones (see section 5.1.3 "Text input" on page 166).
- 9 Installation slots for additional controls and digi-adjusters (see section 2.3.4 "Installing additional controls" on page 36).
- 10 Lug for attaching a support strap (# 8 5161 or # 8 5646).
- 11 Two sliders (controls <G and H>) for channel and / or switched functions.

Annular light

The annular light indicates the status of the RF module during operation:

- Yellow flash: Normal mode, full transmitting power.
- Red flash: Range check; reduced transmitting power (see page 46).
- Flashing orange light: A binding procedure is in progress (see page 47).
- Solid light: A PC is or was connected. No RF is generated.
 - Yellow: Battery charging is in progress.
 - Red: The battery is not charged.

Warning lights



Press the **ENTER** button to clear the warning bar if status display #2 is shown.

The warning lights serve as markers for the sensor alarms.
The following warning lights are assigned to the sensors:



- Battery icon: voltage sensors
- Thermometer: temperature sensors
- Petrol pump: level and battery charge sensors
- IC icon: ECU (Engine Control Unit)
- Warning sign: speed and current sensors

2.1.2 Underside view



Figure 2: Underside view of the transmitter

- 1 Recessed control for the sliding latch for USB sockets (see section 2.1.5 "Connectors" on page 29)
- 2 Fasteners for opening the case (see section 2.3.1 "Opening and closing the case" on page 31)
- 3 Carry bars

2.1.3 Carry handle / bars

The carry bars are located inside a drawer which also serves as a handle to carry the transmitter.

2.1.3.1 Carry handle

If you want to use the drawer as a carry handle, pull it out completely (figure). The carry bars are locked in this position.



2.1.3.2 Carry bars

Pull out the drawer only up to the point where the inside bar is fully exposed. This is the only position where the bars are unlocked and can be swivelled out (figure).



Carefully swivel out the bars until they snap into place. The drawer can be pulled out completely to serve as a carry handle or pushed into the back case cover to be stored away.

NOTICE

Only in this position of the drawer (figure) are the carry bars unlocked. In all other positions, the carry bars cannot and must not be swivelled out.

Using force will damage the swivel mechanism!

2.1.4 The interior

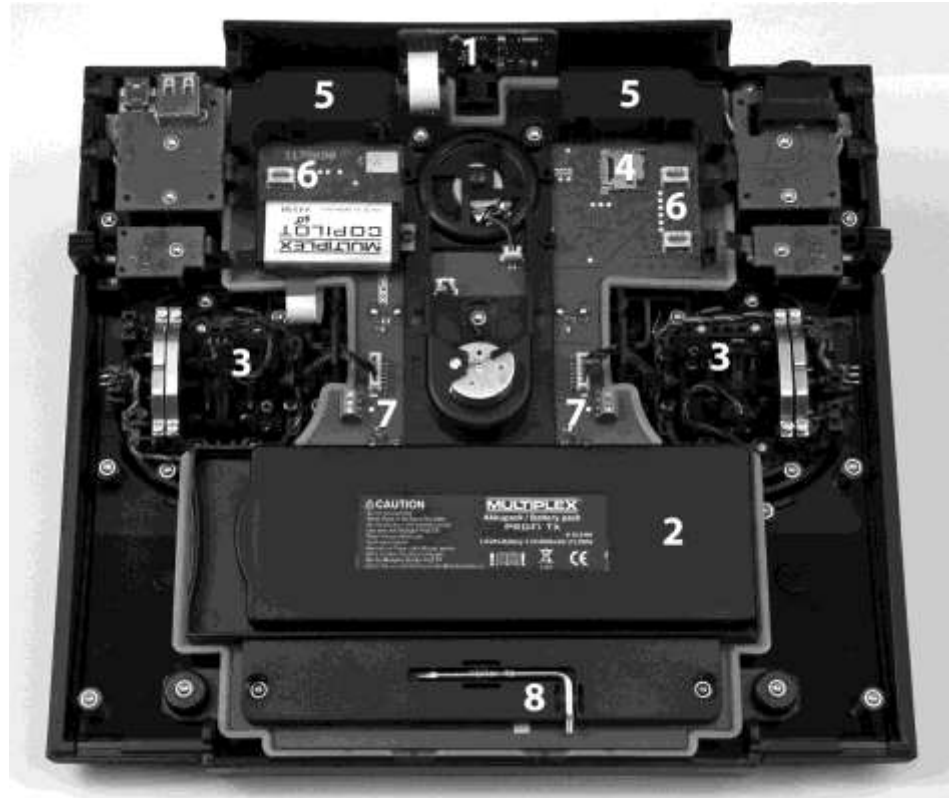

Figure 3: The interior of the transmitter

- 1 RF module with IOAT aerial
- 2 Transmitter battery (see section 2.4 "Transmitter battery" on page 40)
- 3 Control units
- 4 microSD card
- 5 Covers for the slots for controls installable on the front
- 6 4 slots for additional modules (see section "Installing additional modules" on page 39)
- 7 2 clamp terminals for connecting the controls installable on the stick tops (see section "Installing stick tops with a switch or button" on page 35)
- 8 TORX screwdriver

2.1.5 Connectors

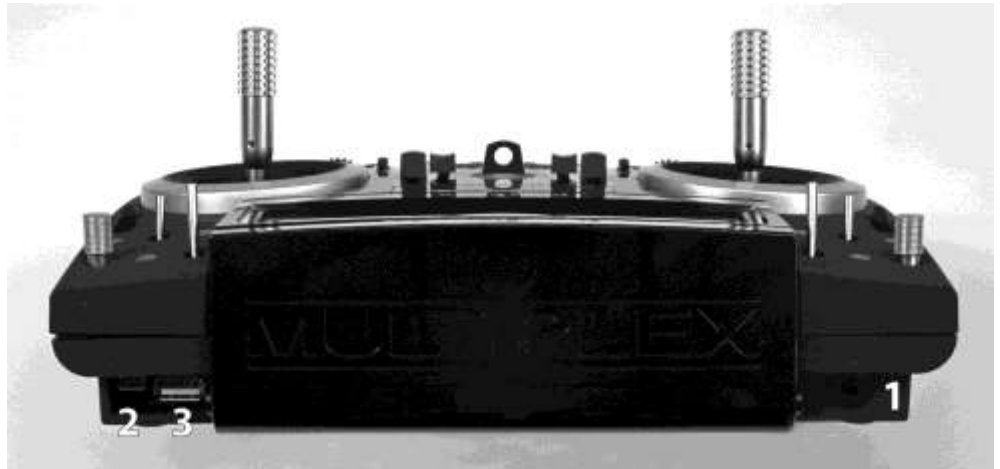

Figure 4: Connectors on the transmitter

- 1 Headset connector (stereo jack); when a headset is connected, the loudspeaker of the **PROFI TX** is switched off
- 2 Mini USB socket for connecting the **PROFI TX** to a PC and for charging the battery via the charging socket (see section 2.4.1 "Charging the battery" on page 40)
- 3 USB-A socket for future expansions

2.2 Initial setup

The following steps should be performed during initial setup of your **PROFI TX**. Refer to the relevant sections listed below for a detailed description.

Briefly charge the battery. It is sufficient to charge the battery for one hour on the PC (500mA) or for 20 minutes via the plug-in charger (1.5A): Refer to section 2.4 "

Transmitter battery" on page 40 for details.

1. Switch on the transmitter: Press and hold the Power button until the annular light is fully lit. The device is switched on when you release the button. Refer to section 2.5.1 "Switching on" on page 44.
2. Select the language to be used in the menus and the texts in the model templates:
Refer to section "Switching on for the first time" on page 45.
3. Switch off the transmitter: Press the Power button until the annular light turns off. The device is switched off when you release the button. Refer to section 2.5.2 "Switching off" on page 45.
4. Open the case of the transmitter:
Refer to section 2.3.1 "Opening and closing the case" on page 31.
5. Adjust the stick units to suit your ergonomic preferences.
 - If necessary, swivel the stick units:
Refer to section 2.3.2.1 "Swivelling stick units" on page 33.
 - Activate the stick ratchet:
Refer to section 2.3.2.2 "Adjusting ratchet, friction and centring force" on page 34.
6. If necessary, install additional switches:
Refer to section 2.3.4 "Installing additional controls" on page 36.
7. Install the receive system and connect the servos.
 - Perform the binding procedure to bind the receiver with the transmitter:
Refer to section "Binding" on page 47.

2.3 Mechanical operations on the transmitter

2.3.1 Opening and closing the case

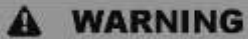
**WARNING**

Danger of short-circuit!

Switch **off** the transmitter before opening the case.

Opening the case

1. Switch off the transmitter.
2. Remove the USB and headset cables.
3. Place the transmitter upside down on a soft surface.
4. Press and hold the two fasteners on the side of the screen and gently lift the back case cover.



5. Release the fasteners, flip up the back case cover and remove it.



Closing the case

6. Remove the USB and headset cables.
7. Place the transmitter upside down on a soft surface.
8. Move the controls on the side to the centre position.

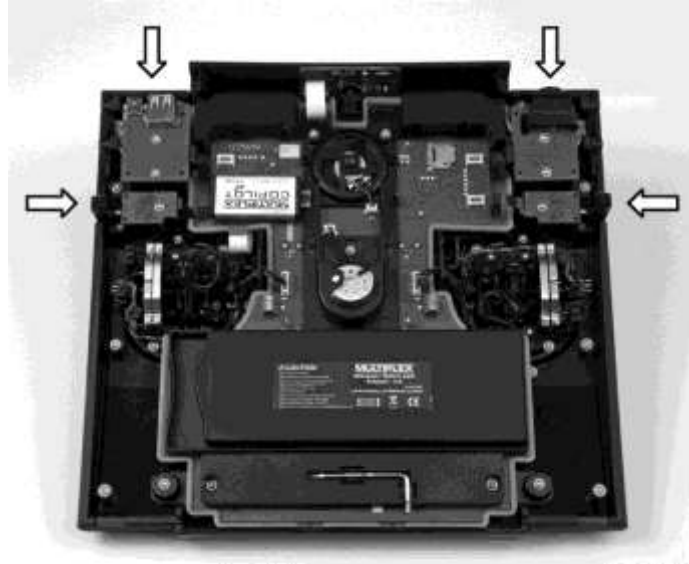

9. Place the lower edge of the back case cover vertically onto the case.



10. Swivel the back case cover to the front, push down and press gently to snap it into place.

2.3.2 Adjusting stick units

2.3.2.1 Swivelling stick units

The "natural working axis" of your hands is at a more or less pronounced angle. The stick units of the **PROFI TX** can be swivelled to perfectly suit your ergonomic preferences. The swivelling range is approx. 15°.



Figure 5: Swivelling stick units

Proceed as follows:

1. Using the TORX screwdriver, loosen the three TORX screws retaining the appropriate stick unit until the unit can be swivelled.

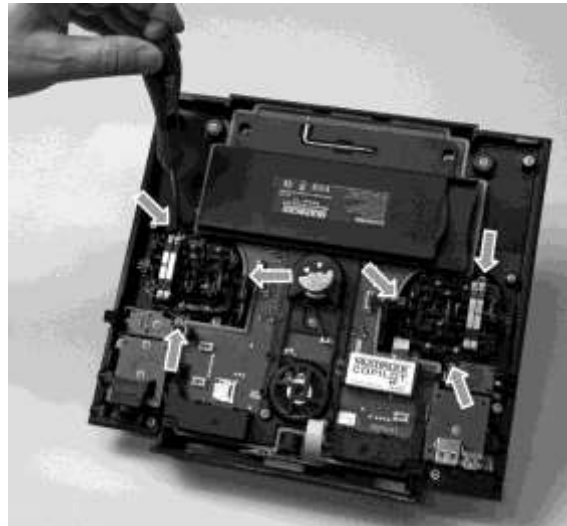

2. Swivel the stick unit to the most comfortable angle for use.
3. Tighten the screws again.

NOTICE

Take care not to over-tighten them or you might strip the threads.

2.3.2.2 Adjusting ratchet, friction and centring force

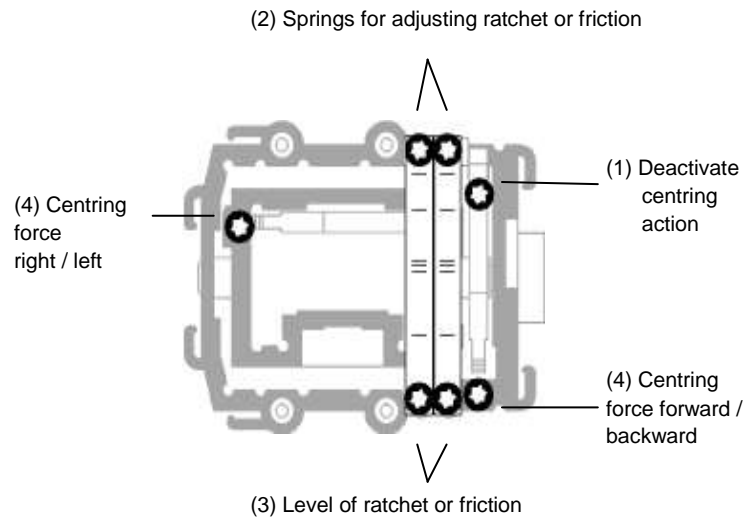

Figure 6: Adjuster screws on the stick

Ratchet and friction

The **PROFI TX** is supplied as standard with self-centring sticks. The springs for use with a ratchet or friction system are already fitted to both stick units, and can be activated quickly and easily.

The screws (2) hold the springs. The screws (3) are used to adjust the level of ratchet / friction action. The more the screw is tightened, the harder the ratchet or friction.

If required, you can set a superimposed ratchet / friction action by activating both springs on one stick. This will help you achieve perfect control as needed.

1. Switch off the transmitter and open it.
2. Using the TORX screwdriver, tighten the TORX screw (turn clockwise) on the appropriate centring lever (1) to the point where the stick centring action is completely disabled.

NOTICE

Do not over-tighten the screws. Do not disassemble the centring lever and/or the centring spring.

2.3.3 Installing stick tops with a switch or button

MULTIPLEX® offers three different stick tops with switch or button for the **PROFI TX** (see section 10.2 "Accessories" on page 213).

To install a new stick top proceed as follows:

1. Switch off the transmitter and open it.
2. Remove the battery¹.
3. Loosen the grub screw at the bottom of the stick top (1.5mm slot-head screwdriver).
Pull off the top from the stick shaft.



4. Wrap the flexible wires of the new stick top with a thin enamelled copper wire. Tightly bend back the section without insulation.

Thread the enamelled copper wire through the borehole on the stick shaft until it is visible at the bottom of the stick unit. Use a pair of pliers to pull the wire out until you can grab it with your fingers.

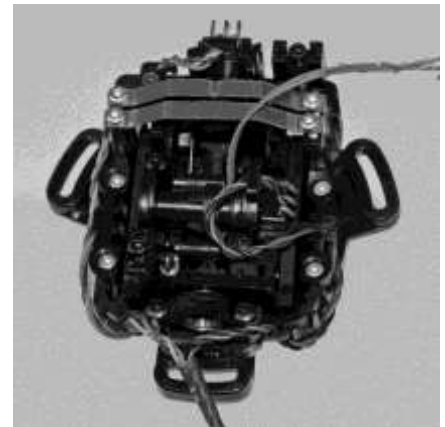

5. Gently pull on the wire until you can grab the flexible wire with your fingers. This will be easier if you turn the stick shaft on the side opposite the point where the wire exits.
6. Slide the stick top onto the stick shaft, simultaneously pulling the flexible wire completely through.
7. Tighten the grub screw on the stick top.

8. You can see one three-pin terminal clamp next to every

¹ After re-inserting the battery, date a

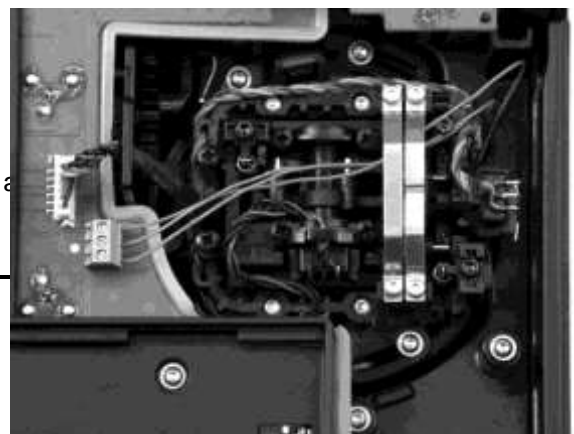

stick unit on the main circuit board of the device. Remove the wire.

Clamp the blue flexible wire to the centre terminal and the red wire(s) to the output terminal(s).

9. Insert the battery and close the transmitter.
10. Switch on the transmitter.
11. Verify that the switch operates correctly.

To test this, assign the new stick switch to any switched function in the `Setup > Assign.Switches` menu.

Stick tops

The standard tops can be replaced with the following stick tops (see also section 10.2 "Accessories" on page 213):

- [Aluminium stick top, long, with 2-position switch](#)
Item No. 85940
- [Aluminium stick top, long, with 3-position switch](#)
Item No. 85941
- [Aluminium stick top, long, with push-button](#)
Item No. 85942

2.3.4 Installing additional controls

You can install 8 controls on each side of the **PROFI TX** (see section 2.1 "Transmitter overview" on page 23).

- The 7 controls can be buttons, 2- or 3-position dip-switches, or rotary potentiometers in any arrangement.
- In addition, a digi-adjuster can be installed on each side. You can assign a parameter for direct configuration to each digi-adjuster (see section 5.3 "Digi-adjuster" on page 168).

To install a control proceed as follows:

- 1 Switch off the transmitter.
- 2 Disconnect the headset and USB cables.
- 3 Unscrew the knobs from all the digi-adjusters and potentiometers.

- 4 Open the transmitter.
- 5 Remove the battery.
- 6 Open the cable cover on the side where you wish to install the additional control. When the control is installed on the right side, the cover of the headset socket must also be removed. To this end, use a screwdriver to pry away the clip on the right side and swivel the cover out to the front.



- 7 Loosen the 2 screws on the circuit boards on top of the switch tray using the TORX screwdriver.



- 8 Lift off the circuit boards and place them nearby. Remove the two screws on the switch tray.



- 9 Lift out the switch tray and remove the blind plugs from the required installation slots.



- 10 Install the controls. Observe the installation direction for dip-switches: The red cable must face the transmitter front.

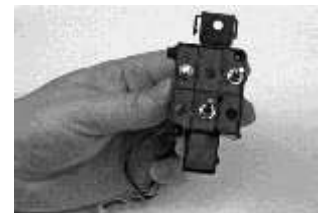

- 11 Replace the switch tray and secure it using the screws.
- 12 Replace the circuit boards and secure them using the screws. Replace the cover over the headset socket and make sure that the clips snap into place.
- 13 Refit the connectors of the controls.
- 14 Close the cap on the slots.
- 15 Insert the battery and close the transmitter.

- 16 Switch on the transmitter.
- 17 Verify that the controls operate correctly.
To test this, assign the new controls to any switched function in the `Setup > Assign. Switches` menu.
- 18 Screw the tops of the digi-adjusters and potentiometers back on.
- 19 Date and time have to be set again in the Timer menu, as the battery was removed.

Additional controls

The following additional controls can be installed in the **PROFI TX** (see also section 10.2 "Accessories" on page 213):

- [2-position switch \(micro\), short](#)
Item No. 75750
- [2-position switch \(micro\), long](#)
Item No. 75751
- [3-position switch \(micro\), short](#)
Item No. 75752
- [3-position switch \(micro\), long](#)
Item No. 75753
- [Digi-adjuster](#)
Item No. 75755
- [Rotary knob \(micro\)](#)
Item No. 75756
- [Push-button \(micro\)](#)
Item No. 75754

2.3.5 Installing additional modules

You can add four modules to the **PROFI TX**.

NOTICE

Never install two identical modules!

When these operating instructions were released for print, only the COPILOT module (item no. 45184) was available (see section 10.2 "Accessories" on page 213).

To install a module proceed as follows:

- 1 Switch off the transmitter.
- 2 Disconnect the headset and USB cables.
- 3 Open the transmitter.
- 4 Insert the module in one of the 4 slots and make sure that the respective fixing clip faces the transmitter centre and is aligned with a fixing bore on the central plastic part.

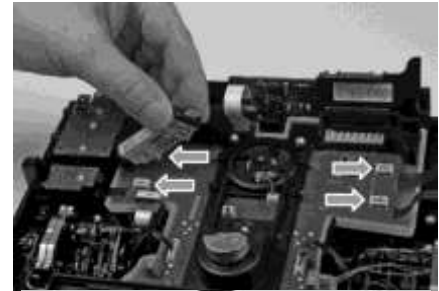

- 5 Tighten the screw supplied.
Take care not to over-tighten the screw.



- 6 Close the transmitter.
- 7 Switch on the transmitter.
- 8 Verify that the module operates correctly. Refer to the section "Trainer mode" on page 49 for more details.

2.4 Transmitter battery

The **PROFI TX** is powered by a robust and durable **LiFePO4** battery. The battery is installed with the electronic system for battery management in a welded case. If the battery is new, the battery capacity of 4000mAh provides an operating time of more than 30 hours. Additionally installed components increase power consumption and shorten the operating time. If the device is exposed to temperatures below -10°C, the operating time is significantly reduced.

2.4.1 Charging the battery

The **PROFI TX** features two USB sockets at the front on the right-hand side of the case, which are protected by a sliding latch. The mini USB socket is used for charging (see section 2.1.5 "Connectors" on page 29).

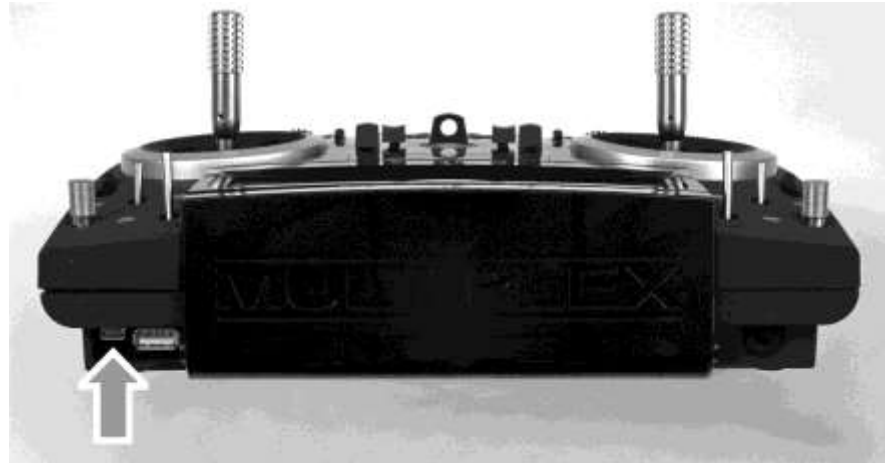

The following options are available for charging the **PROFI TX**:

- Via your PC or laptop
- Via the MULTIPLEX USB car plug-in charger 12V DC (item no. 145533)
- Via the MULTIPLEX USB plug-in charger 100-240V AC (item no. 145534, see section 10.2, "Accessories" on page 213)

NOTICE

The transmitter must not be connected to a charger when no battery is installed!

Without a consumer, the charger can provide unacceptably high output voltages. These voltages can damage the transmitter.

2.4.1.1 Charging via the PC

Proceed as follows:

1. Switch off the **PROFI TX**.
2. Lift the device. The recessed control for the sliding latch is located on the underside of the case.
3. Slide the sliding latch towards the device centre.
4. Switch on the PC. Connect the supplied USB cable to a USB socket on the PC and to the mini USB socket on the **PROFI TX**.
 - The **PROFI TX** starts automatically in charging mode.
 - The figure below is shown on the screen.
Maximum current: 500mA.

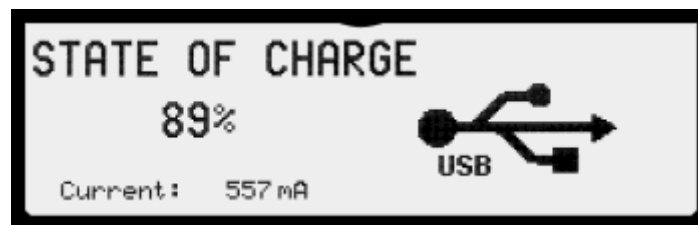

The **PROFI TX** logs into the PC as mass storage with the name "**PROFI TX**".

NOTICE

Upon first time use, the PC automatically installs device drivers. Do not switch off the PC and/or the transmitter and do not disconnect the USB cable while the installation is in progress. This may take several minutes. Some operating systems require an active Internet connection for this process.

If you press and hold the Power button until the annular light is fully lit, the transmitter switches from charging mode to normal mode. The **PROFI TX** logs off from the PC as USB mass storage and logs in again as a game controller (see section 6 "Operating the transmitter " on page 176).

The RF module is disabled while a USB connection is established. It also remains switched off after disconnection. Otherwise, the RF module would be re-enabled when the host (PC, laptop, etc.) is switched off.

2.4.1.2 Charging the battery using the plug-in charger

Proceed as follows:

1. Lift the device (the recessed control for the sliding latch is located on the underside of the case).
2. Slide the sliding latch towards the device centre.
3. Connect the supplied USB cable to the plug-in charger and to the mini USB socket on the **PROFI TX**.
4. Connect the plug-in charger to a mains outlet.

The plug-in charger icon is shown on the right side of the screen and the state of charge and the charging current are displayed on the left. Maximum current (depending on charger and state of charge): 1500mA.

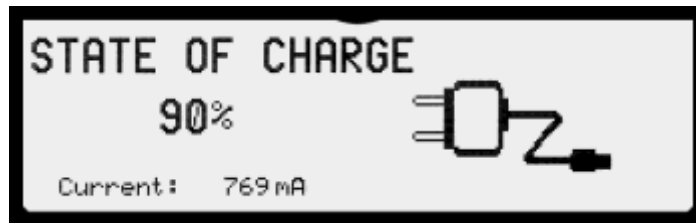

2.4.2 Removing the battery

1	Open the transmitter.	
2	Slide the battery to the left towards the empty area in the battery dock.	
3	Remove the battery.	
4	Place the battery on a non-conducting, dry surface.	

2.4.3 Inserting the battery

1	Insert the battery on the left side of the battery dock, with the rounded side facing to the left.	
2	Slide the battery to the right until the stop is reached.	

2.4.4 Battery management

The **PROFI TX** records the current during transmitter operation and while charging the transmitter battery. The available battery charge is calculated on the basis of the power meter reading, the temperature and the voltage. The remaining operating time (time to empty) is calculated from charge and current and is shown on status display #2 (see page 88). The calculation takes into account that current consumption slightly decreases with decreasing battery voltage.



Battery alarm

If the remaining operating time falls below a configurable threshold, the remaining operating time is announced with increasing frequency. The "TX-BATT." section on the left side of status display #2 flashes.

The factory setting for the alarm threshold is 60 minutes. This value can be changed in the `Setup > Transmitter > Battery alarm` menu (see section 4.3.9 "Transmitter" on page 114).

Self-discharge

If the transmitter is stored for a prolonged period, the available battery charge is estimated based on the idle voltage when the transmitter is switched on. For this reason, the displayed charge and time to empty are not initially very accurate. After one to two charge / discharge cycles the original accuracy is restored.

Under-voltage cut-off

If the operating voltage falls below 2.8V, the device is automatically switched off without further warning. If the voltage is below 2.9V, it cannot be switched on: The following message is briefly displayed on the screen: `BATTERY DOWN!`

Charge the transmitter battery!

NOTICE

If voltage is low, recharge the battery as soon as possible (within 1-2 days) to avoid damage due to deep discharge. Observe the notes on charging (see section 2.4 "Transmitter battery" on page 40).

2.5 Switching the transmitter on / off

NOTICE**Charge the transmitter battery!**

The **PROFI TX** is supplied with a partially charged transmitter battery. You should charge the battery prior to setup. Please observe the notes on charging (see section 2.4 "

Transmitter battery" on page 40).

2.5.1 Switching on

To switch on the device proceed as follows:

1. Press and hold the Power button until the annular light is fully lit. The device is switched on when you release the button.
-



If you press and hold the Power button for a prolonged period, the annular light turns off again and the device is not switched on when you release the button (power-on protection).

2. At this point, either the safety check prompt is displayed on the screen:



Or the language selection screen is shown, if the menu language has not yet been selected (see section "Switching on for the first time" on page 45).





The RF module is switched off until the safety check is completed to prevent the servo from moving to an undesired position.

3. Check if safety-related controls such as landing gear switches, flight phase switches, and throttle sticks are in the proper position.
 4. Press a button on the keypad: The safety check is completed, the RF module is switched on, and status display #2 is shown.
-

You can switch the safety check on and off in the `Memory > Safety check` menu. The safety check is activated by default when you create new model templates (see page 162).

Switching on in Binding mode

- Press and hold the  button during startup until the status display is shown.
- Switching on for range check

Press and hold the  button during startup until "Safety check" or the status display is shown: The device starts up with reduced transmitting power when the range check is performed (see section 2.6 "Range check" on page 46).

Switching on for the first time

The very first time you switch on the **PROFI TX** is a special case. A language selection menu is shown on the screen after startup. Here, you select the language for:

1. Menus
2. Names of mixers, timers and control functions in the model templates
3. Speech output



The language is selected using the keypad (up/down/ENTER). If you select "skip/später", transmitter functionality is restricted: Only one model memory is available and its contents are not stored on the SD card when the device is switched off. The menu is shown in English.

2.5.2 Switching off

Press and hold the Power button until the red annular light turns off completely to switch off the device. The device is switched off when the annular ring turns off and the button is released. If you press and hold the button for a prolonged period, the annular ring returns to ready status. Now, you can release the button without the device switching off (power-off protection).

2.6 Range check

Regular range checks are necessary for ensuring the reliable functioning of the radio control system and for timely detection of changes in transmission properties.

Always perform a range check after:

- installing, modifying or rearranging components in the model,
- reusing components in the model that were involved in a crash,
- observing irregularities when operating the model.

The transmitting power can be significantly reduced for the range check, enabling short distances between transmitter and model.

While the range check is active the status displays #2 to #8 show the flashing message: **RANGE!** with the annular ring flashing red. A warning is announced every minute to alert the operator. The warning is only announced when you are not navigating in menus so as not to disturb you when performing configurations.



Recommended minimum distance: 40m to 100m, depending on receiver type.
Refer to the receiver operating instructions for detailed information.

NOTICE

Always perform a range check before starting up the model.

A second person must always be present for the range check to secure and observe the model.

Large metal objects within or in close proximity to the checking range (wire fences, cars) affect the result of the range check.

Procedure

1. If the model is fitted with a power system, switch it off!
2. Press and hold the  button on the transmitter as you switch the transmitter on.
3. Switch on the receiver.
4. In the `Servo > Test` run menu, activate the test run for a control function, e.g. Elevator. This allows you to check that the receive system responds to control commands with distinct, regular movements of the control surfaces.
5. Increase the distance between transmitter and model. You have reached the range limit when the servos start to jitter.
6. Repeat the check with the power system running. Secure the model. Perform the check using throttle positions that vary between idle and full throttle. In case of electric power systems, the most significant interferences occur at half throttle.
The range should not diminish significantly.
7. Otherwise, eliminate the cause of the interference (power system, installed position of the receive system with power supply).

Factors influencing the radio range

The following factors have significant influence on the radio range:

- Environmental conditions
Hilltops, ground characteristics, type of terrain, and the atmospheric conditions affect radio range.
- Receiver technology and sophistication
Technically sophisticated receivers have a greater range than simple, cheap receivers.
- Installation situation in the model
Installation position / arrangement of the aerials and the distance to batteries, power systems, servos, ignition systems, metal / carbon fibre parts influence the radio range.

Binding

The binding procedure binds the receiver with the transmitter.

M-LINK uses "frequency hopping" and "spread spectrum".

No fixed transmission channel is used for "frequency hopping", but all 39 channels are used in a sequence that is defined by the transmitter.

For "spread spectrum", every data bit is coded in 64 bits (spread). This procedure provides a high level of immunity to interference. During binding, the transmitter passes "hopping sequence", "spreading code", and "response time" to the receiver.

Procedure

The binding procedure can be started in 2 ways: via the keypad during startup or via the menu.

Starting the binding procedure when the device is switched on:

1. Press and hold the  button for the full duration of the transmitter startup procedure.
 - The annular ring of the Power button is flashing in orange and the flashing message "BINDING" is shown in the status displays #2 to #8.
2. Now, switch on the receiver while pressing and holding the Set button (connect the power supply).
 - The receiver LED is flashing rapidly.
3. The binding procedure is completed within a few seconds:
 - The annular light returns to flashing yellow.
 - The receiver LED is flashing slowly.
 - The servos that are connected to the receiver can now be controlled.

Starting the binding procedure via the menu

1. Switch off the receiver and switch on the transmitter.
 - Press the  button to open the "Setup" menu.
 - Use the wheel to select the "M-LINK" menu item. Press the wheel.
 - Open the "Binding" menu item. Press the wheel. The input field **OFF** is now highlighted.
 - Turn the wheel to the right: The text "seeking.." is now displayed in the input field and the annular light of the Power button is flashing in orange. The transmitter is searching for a receiver in binding mode.
 - You can cancel the binding procedure at any time: Turn the wheel to the left. The previous condition is restored.
2. Now, switch on the receiver while pressing and holding the Set button (connect the power supply).
 - The receiver LED is flashing rapidly.
3. The binding procedure is completed within a few seconds:

- The input field briefly shows the text "OFF" and then indicates the detected type: "RX", "RX-ID", "MultiFlight", "Teacher" or "Student".
- The annular light returns to flashing yellow.
- The receiver LED is flashing slowly.
- The servos that are connected to the receiver can now be controlled.



If the binding procedure does not complete automatically within a few seconds, move the transmitter front closer to the receiver aerial(s).



The **Setup > M-LINK > Binding** menu item indicates if and what type of receiver is currently connected to the **PROFI TX**.

The ID is displayed for ID receivers.

2.7 Trainer mode

The trainer mode (teacher / student) is the safest method for beginners to get started in model sport.

An experienced model pilot has control over the model as the teacher. The trainer can transfer control functions to the student by operating a button. Initially these will be individual control functions, and later all the main control functions will be transferred.

The **PROFI TX** can be configured either as a teacher transmitter or as a student transmitter. The teacher and student transmitters are inter-connected using a second M-LINK radio link.



If the radio link between the student and the teacher is lost, all the control functions are returned to the teacher.

Student mode

In Student mode, the control signals of the sticks and sliders are transferred via M-LINK to the teacher transmitter (without trim and travel settings).

A second **PROFI TX** with COPILOT module or another MULTIPLEX transmitter with trainer stick can be used as the teacher transmitter.

Refer to "Training" on page 99 for details.

Teacher mode

A free switch on the teacher transmitter and the COPILOT module are required for the Teacher mode (see section 10.2 "Accessories" on page 213):

- Refer to section 2.3.4 "Installing additional controls" on page 36 for information on how to install a switch.
- Refer to section 5.4.2 "Assign.Switches" on page 173 for information on how to assign the switch to the trainer function.
- Refer to section 2.3.5 "Installing additional modules" on page 39 for information on how to install the COPILOT module.

In Teacher mode, the selected control functions can be controlled by the student transmitter. These control functions are selected in the `Setup > Training` menu. The selection list is only available in Teacher mode.

2.8 Digital trim

2.8.1 Overview

"Trimming" refers to the adjustment of the model aircraft to fly straight and level when you leave the sticks exactly at centre.

Digital trim has two essential advantages:

- Digital trim buttons do not have any physical position corresponding to the actual trim value (which is the case for conventional trim with trim sliders). The digital trim position is displayed on the screen, and any change to the trim values is stored in the model memory. If you switch model memories, there is no need to move the trim sliders to the correct position to suit the model. The correct trims are immediately available.
- In models for which you have set up multiple flight phases each flight phase has its own trim memory, i.e. it is simple to trim each flight phase accurately, and independently of the trims in the other phases.

Example

The model aircraft should fly straight and level when you leave the sticks exactly at centre. If this is not the case, the neutral point of the causal control function should be corrected / trimmed.

Centre trim

The **PROFI TX** enables digital trim on each of the 4 stick axes.

"Centre trim" is applied to the main control functions "Aileron", "Elevator", and "Rudder". For "Throttle" you can choose between idle and centre trim. The centre trim only affects the control centre, but not the end-travels. Unlike standard trim, this offers the advantage that no control travel must be reserved for trimming: the servo travel is used fully.

Both servo end-points remain unchanged, regardless of the current trim position.

2.8.2 Trim buttons

On the **PROFI TX**, trimming is carried out using the trim buttons arranged below and to the side of each stick unit (see section 2.1.1 " Top view" on page 23).

Every time you press a button the associated control axis is trimmed in the direction in which the pressure is applied to the button. If you press and hold the trim button for more than about 0.8 sec., the trim value changes continuously until you release the button again (AUTO-REPEAT function). When the trim reaches the neutral position, the AUTO-REPEAT function stops briefly.

Each trim increment is accompanied by an audible signal. On reaching the neutral position or the end-point, specific audible signals are emitted.

As an option, the current trim value can be announced when the trim button is released. You can activate this announcement in the `Setup > Transmitter > Sounds` menu (see section 4.3.9 "Transmitter" on page 114).

2.8.3 On-screen trim display

Graphic display

The trim positions are displayed as bars on both sides and at the bottom of the screen in the status displays #2 to #8:



Figure 7: On-screen trim display

Starting from the centre position, the trim range is 20 increments in both directions. The trim increment (step, or adjustment rate) can be set to any of the following values: 0.5%, 1.5%, 2.5%, 3.5% (ControlFunctions > respective control function, Step size parameter, see section 4.4 "4.4ControlFunctions main menu" on page 118).



Switching the step size changes the trim value percentage since the number of stored trim increments remains the same. This means if you alter the trim increment size, you must remember to re-trim the model.

The design of the graphic trim display can be selected (Setup > Transmitter > Screen, Trim graph parameter, see section 4.3.9 "Transmitter" on page 114).

2.9 microSD card

2.9.1 Replacing the microSD card

- Open the transmitter.
- Use a finger nail to carefully pull the metal card bracket (top part of the socket) towards the transmitter centre to release the card bracket.
- Flip up the card bracket and remove the card.
- Insert a new card into the card bracket (terminals facing to the back and down).
- Fold down the card bracket. Push the bracket with the card slightly back until it snaps into place.

2.9.2 microSD card from a different transmitter

When inserting a card that was used in different transmitter, you must briefly remove the transmitter battery before switching on the transmitter. This erases the copy of the last model memory from the microcontroller RAM. Erasing the model memory prevents the transmitter from using the RAM copy further and accidentally overwriting the model memory with the same number on the new card when the transmitter is switched off.

2.9.3 New microSD card

- Switch on the PC. Open the "Computer" or "My Computer" pane in the file explorer.
- Switch off the transmitter. Connect the transmitter to the PC via the USB socket. After a few moments, you see an additional drive. That is the SD card in the PROFI TX.
 - Right-click the new drive to open the context menu.
 - Select "Format". Make the following selection in the next menu: file system: FAT; allocation unit size: 32 kilobytes; quick format
 - Click "Start".
- Rename the card to "PROFI TX":
 - Right-click the new drive to open the context menu.
 - Select "Properties".
 - Enter the text "PROFI TX" in the input field.

- Click "OK".
- Now, copy the directory structure to the PROFITX that is described below. A zip file containing this directory structure is available in the Downloads section of our home page.

2.9.3.1 Directory structure on the microSD card

The microSD card must contain the following 3 folders in the root directory:

AUDIO	Contains the 3 subdirectories DE, EN and FR. The subdirectories contain sound and speech output files for each language.
DATA	The model memories are stored in this folder. The file names are written in capitals and start with "PTX" followed by the model number (3-digit with leading zeros). The file name extension is .MDL.
UPDATE	Updates are placed in this folder. If the transmitter detects an update file during startup, the update procedure is started. The file is deleted upon successful completion of the update procedure.

3 Model templates

- Templates for fixed-wing models
 - BASIC, see page 58
 - ACRO, see page 61
 - GLIDER+, see page 61
 - DELTA WING, see page 67
 - FLYING WING, see page 69
 - BIG SCALE, see page 71
- Templates for helicopter models:
 - FUNCOPTER, see page 75
 - HELI FBL, see page 76
 - HELI mech., see page 77
 - HELI cCPM, see page 77
- Templates for land- or water-based models and tracked vehicles
 - CAR / TRUCK, see page 80
 - SHIP / BOAT, see page 82
 - TRACKED V., see page 84

Switch assignment

In the **PROFI TX**, all the switches can be installed and connected as needed. For this reason, switched functions that are usually assigned to dip-switches or buttons cannot be pre-set in the model templates. You have to configure these assignments yourself according to the existing switches.

Using timers

The Frame, Sum, and Interval timers are only functional if a switch has been assigned to them. The same control that is used for the Throttle control function is assigned to the sum timer in all model templates. For this reason, this timer is immediately functional. You activate the other timers by assigning a switch to them.

Control mixers (Ctrl.Mix)

The **Ctrl.Mix** control mixers are not initialised in the templates.

3.1 Templates for fixed-wing models

All the templates for fixed-wing models use similar names for the 15 control functions. Only the Throttle and Spoiler assignments differ:

- For power models, Throttle is assigned to a stick, Spoiler is assigned to slider <E.
- For glider-type models, Spoiler is assigned to the stick, Throttle is assigned to slider <E.

Controls assignment, control function, and settings

Control function	Control	Setting	Parameter
Aileron	[Mode]	Trim ^{FP4} Step size Expo ^{FP4} D/R Travel ^{FP4}	0% 1.5% 0% 100% 100%
Elevator	[Mode]	Trim ^{FP4} Step size Expo ^{FP4} D/R Travel ^{FP4}	0% 1.5% 0% 100% 100%
Rudder	[Mode]	Trim ^{FP4} Step size Expo ^{FP4} D/R Travel ^{FP4}	0% 1.5% 0% 100% 100%
Throttle	BASIC, ACRO, DELTA WING, BIG SCALE: stick GLIDER+: <E	Trim ^{FP4} Step size Mode Expo Slow	0% 1.5% HALF 0% 0.0s

Spoiler	BASIC, ACRO, DELTA WING, BIG SCALE: <E GLIDER+: stick	Slow Fixed value ^{FP4}	0.0s OFF
Flap ¹	F>	Slow Fixed value ^{FP4}	0.0s OFF
Retract.Gear	---	Slow Fixed value ^{FP4}	0.0s OFF
Towing do9	---	-	-
Wheel Brake	---	-	-
Gyro	---	Type of Gyro Damping/Headin g ^{FP4} Suppression	Heading Control OFF
Mixture	---	-	-
Aux-1	---	Slow Fixed value ^{FP4}	0.0s OFF
Aux-2	---	Slow Fixed value ^{FP4}	0.0s OFF
Aux-3	---	Slow Fixed value ^{FP4}	0.0s OFF
Aux-4	---	Slow Fixed value ^{FP4}	0.0s OFF

^{FP4} = 4 flight phases

¹ Camber-changing flap

3.1.1 BASIC model template

This model template is designed for simple power or glider-type models and for models without aileron.

This model template should also be used for model flying simulators.

Servo assignment

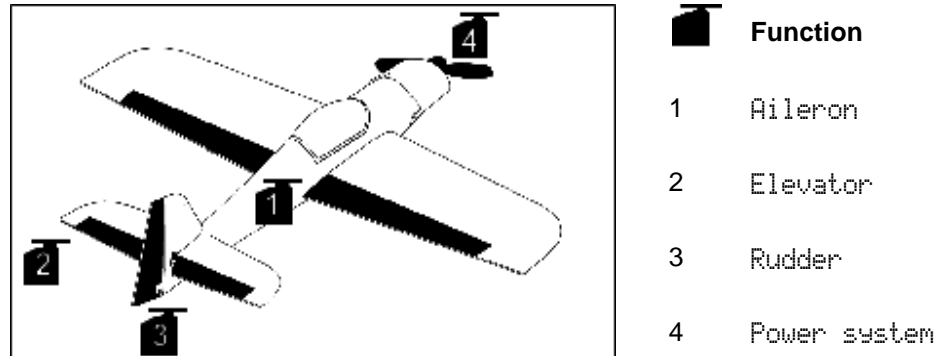

BASIC servo assignment

If you install a second aileron servo to provide separate linkage for the ailerons, simply assign the Aileron function to a free servo (see "Assign" starting from page 149). Would you like to raise the ailerons as an airbrake? In that case, assign the AILERONS+ mixer to both aileron servos at the same position. The extended airbrake will cause major load distribution changes: Change the elevator to ELEVATOR+. It is then possible to compensate for the effects of Throttle and Spoiler (airbrake).

Pre-defined mixers on the control side, with 2 more that can be defined by the operator.

Name	Mixer inputs	Options & settings	Value
Makes it easier to fly accurate turns:			
Combi-Switch	Ail <> rudder	Ail < rudder	OFF
Optimises flying turns:			
Differnt.Ail	Aileron	Mode	OFF

Name	Mixer inputs	Options & settings	Value
		Differnt.Ail	50%



Pre-defined mixers on the servo side in the BASIC template

Name	Mixer inputs	Options & settings	Value
Compensation:			
ELEVATOR+	Elevator	⇅ Up and down travels are asymmetrical	100% 100%
	Throttle-T (untrimmed)	⇩- Single-sided travel, with deadband	OFF OFF
	Spoiler	Single-sided travel, with intermediate point	OFF OFF
Do you use a V-tail model? Reset the control functions "Rudder" and "ELEVATOR+" to "V-TAIL+" in the "Servo > Assign" menu.			
V-TAIL+	Elevator	⇅ Up and down travels are asymmetrical	70% 70%
	Rudder	⇅ 2 Right and left travels are asymmetrical, 2 directions	70% 70%
	Throttle-T (untrimmed)	⇩- Single-sided travel, with deadband	OFF OFF
	Spoiler	⇩ Single-sided travel, with intermediate point	OFF OFF
For airbrake and aileron differential. Requires 2 AILERONS+ servos.			
AILERONS+	Aileron	⇅ 2 Travels are symmetrical	100% 100%

	Spoiler	↕+	Single-sided travel, with offset	OFF	OFF
--	---------	----	----------------------------------	-----	-----

3.1.2 ACRO model template

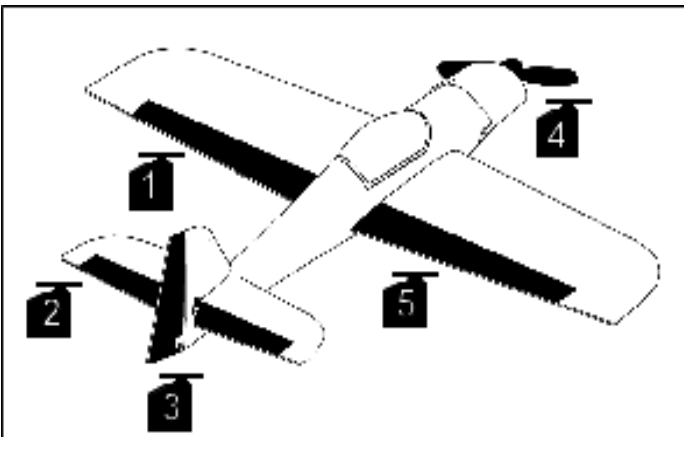
- The ACRO model template is suitable for power models with up to 4 flaps, optionally with snap flap.

		Function
	1	AILERONS+
	2	ELEVATOR+
	3	Rudder
	4	Power system
5	AILERONS+	
ACRO servo assignment		

Pre-defined mixers on the control side, with 2 more that can be defined by the operator.

Name	Mixer inputs	Options & settings	Value (%)
Combi-Switch	Ail <> rudder	Ail < rudder	OFF
Differnt.Ail	Aileron	Mode	+SPOILER
		Differnt.Ail	50%

Pre-defined mixers on the servo side

Name	Mixer inputs	Options & settings	Value (%)	
ELEVATOR+	Elevator	 Up and down travels are asymmetrical	100%	100%

Name	Mixer inputs	Options & settings		Value (%)	
	Throttle-T (untrimmed)	↓-	Single-sided travel, with deadband	OFF	OFF
	Landing flaps	↕	Single-sided travel, with intermediate point	OFF	OFF
	Spoiler	↕	Single-sided travel, with intermediate point	OFF	OFF
U-TAIL+	Elevator	↕	Up and down travels are asymmetrical	70%	70%
	Rudder	↕ 2	Right and left travels are asymmetrical, 2 directions	70%	70%
	Throttle-T (untrimmed)	↓-	Single-sided travel, with deadband	OFF	OFF
	Landing flaps	↕	Single-sided travel, with intermediate point	OFF	OFF
	Spoiler	↕	Single-sided travel, with intermediate point	OFF	OFF
AILERONS+	Aileron	↕+2	Travel is symmetrical, 2 directions, with offset	100%	100%

Name	Mixer inputs	Options & settings		Value (%)	
	Landing flaps (increase in lift)	↕+	Single-sided travel, with offset	OFF	OFF
	Spoiler (airbrake)	↕	Single-sided travel, with intermediate point	OFF	OFF
	Elevator-T (snap flap)	↕	Up and down travels are asymmetrical	OFF	OFF
FLAPS+	Flaps (increase in lift)	↕+	Single-sided travel, with offset	100%	OFF
	Aileron	↕ 2	Up and down travels are asymmetrical, 2 directions	OFF	OFF
	Spoiler (airbrake)	↕	Single-sided travel, with intermediate point	OFF	OFF
	Elevator-T (snap flap)	↕	Up and down travels are asymmetrical	OFF	OFF

3.1.3 GLIDER+ model template

- The model template is suitable for glider-type models with up to 8 flaps, optionally with snap flap.

Servo assignment

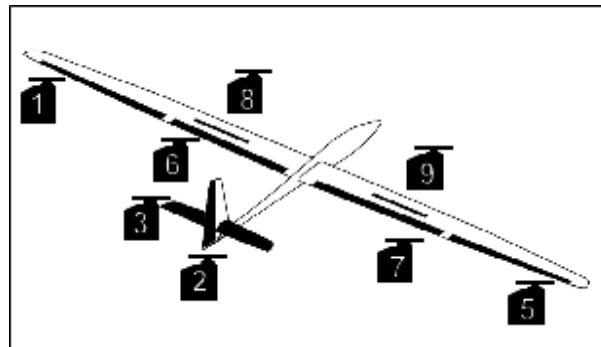

Function
1+5 AILERONS+
2 ELEVATOR+
3 Rudder
4 Throttle
6+7 FLAP_INNR+
8+9 Spoiler

GLIDER+ servo assignment

Pre-defined mixers on the control side, with 2 more that can be defined by the operator.

Name	Mixer inputs	Options & settings	Value
Combi-Switch	Ail <> rudder	Ail < rudder	OFF
Differnt.Ail	Aileron	Mode Differnt.Ail	ON 50%

Pre-defined mixers on the servo side

Name	Mixer inputs	Options & settings	Value
ELEVATOR+	Elevator	⚙ Up and down travels are asymmetrical	1 1 1 1 1 1 1 1

Name	Mixer inputs	Options & settings		V a l u e
	Spoiler	F	Single-sided travel, with intermediate point	
	Flap	⊕	Up and down travels are asymmetrical	
	Throttle-T (without trim)	↓-	Single-sided travel, with deadband	
V-TAIL+	Elevator	⊕	Up and down travels are asymmetrical	
	Rudder	⊕ 2	Right and left travels are asymmetrical	
	Spoiler	↓+	Single-sided travel, with offset	
	Throttle-T (untrimmed)	↓-	Single-sided travel, with deadband	
AILERONS+	Aileron	⊕ 2	Travel is symmetrical, 2 directions	
	Spoiler	↓+	Single-sided travel, with offset	

	Name	Mixer inputs	Options & settings	Value	
		Flap	⊕	Up and down travels are asymmetrical	OFF
		Elevator-T (snap flap)	⊕	Up and down travels are asymmetrical	OFF
FLAP_INNR+	Flap	⊕	Up and down travels are asymmetrical	OFF	OFF
FLAP_CNTR+ ¹	Spoiler	⊕+	Single-sided travel, with offset	OFF	OFF
	Aileron	⊕ 2	Up and down travels are asymmetrical	50%	50%

¹ For centre flap pairs.

3.1.4 DELTA WING model template

This model template is suitable for delta wing models.

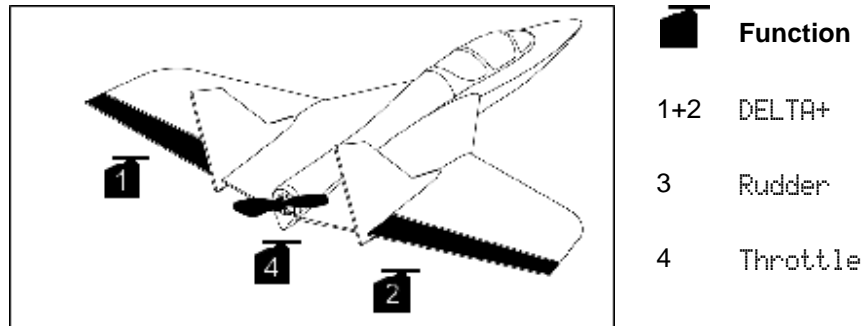

DELTA WING servo assignment

Pre-defined mixers on the control side, with 2 more that can be defined by the operator.

Name	Mixer inputs	Options & settings	Value
Combi-Switch	Ail <> rudder	Ail < rudder	OFF
Differnt.Ail	Aileron	Mode Differnt.Ail	ON 50%

Pre-defined mixers on the servo side

Name	Mixer inputs	Options & settings	Value	
DELTA+	Aileron	⚙️ 2 Up and down travels are symmetrical	70%	70%
	Elevator	⚙️ Up and down travels are asymmetrical	70%	70%
	Throttle-T	⚙️ Single-sided travel, with deadband	OFF	OFF

Name	Mixer inputs	Options & settings		Value	
U-TAIL+	Elevator	⇅	Up and down travels are asymmetrical	70%	70%
	Rudder	⇅ 2	Right and left travels are asymmetrical	70%	70%
	Throttle-T	⇩-	Single-sided travel, with deadband	OFF	OFF

3.1.5 FLYING WING model template

This model template is suitable for models with up to 4 flaps.

Servo assignment

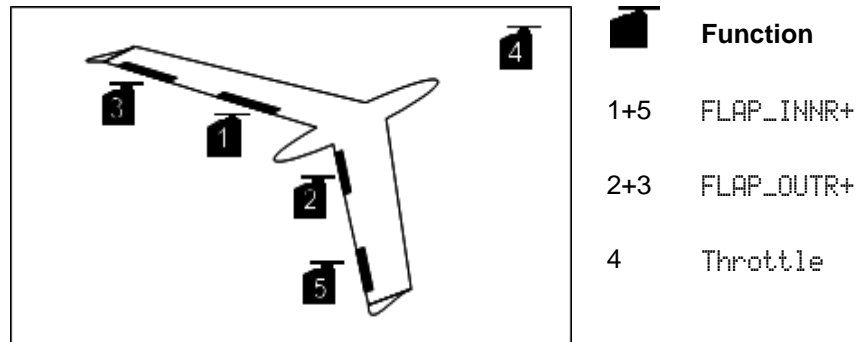

FLYING WING servo assignment

Pre-defined mixers on the control side, with 2 more that can be defined by the operator.

Name	Mixer inputs	Options & settings	Value
Combi-Switch	Ail <> rudder	Ail < rudder	OFF
Differnt.Ail	Aileron	Mode Differnt.Ail	ON 100%

Pre-defined mixers on the servo side

Name	Mixer inputs	Options & settings	Value	
FLAP_INNR+ Inboard flap pair	Aileron	↕ 2 Up and down travels are asymmetrical	70%	70%
	Elevator	↕ Up and down travels are asymmetrical	70%	70%
	Flap (camber-changing flaps)	↕ Up and down travels are asymmetrical	OFF	OFF
	Spoiler	↕+ Single-sided travel, with offset	OFF	OFF
	Throttle-T	↕- Single-sided travel, with deadband	OFF	OFF
FLAP_OUTR+ Outboard flap pair	Aileron (inboard)	↕ 2 Up and down travels are symmetrical	70%	70%
	Elevator	↕ Up and down travels are asymmetrical	70%	70%
	Flap (camber-changing flaps)	↕ Up and down travels are asymmetrical	OFF	OFF
	Spoiler	↕+ Single-sided travel, with offset	OFF	OFF
	Throttle-T	↕- Single-sided travel, with deadband	OFF	OFF

3.1.6 BIG SCALE model template

This model template is suitable for large-scale power models with 2 elevator servos and landing flaps.

Servo assignment

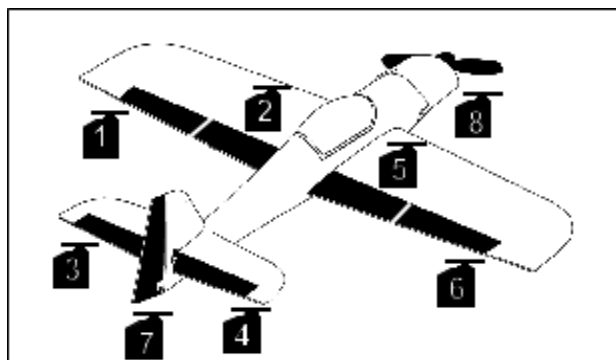

Function
1+6 AILERONS+
2+5 FLAPS+
3+4 ELEVATOR+
7 Rudder
8 Throttle

BIG SCALE servo assignment

Pre-defined mixers on the control side, with 2 more that can be defined by the operator.

Name	Mixer inputs	Options & settings	Value (%)
Combi-Switch	Ail <> rudder	Ail < rudder	OFF
Differnt.Ail	Aileron	Mode	+SPOILER
		Differnt.Ail	50%

Pre-defined mixers on the servo side

Name	Mixer inputs	Options & settings	Value (%)	
ELEVATOR+	Elevator	⬆️ Up and down travels are asymmetrical	100%	100%
	Spoiler	⬇️ Single-sided travel, with centre	OFF	OFF
	Flap	⬆️ Up and down travels are asymmetrical	OFF	OFF

	Throttle-T (untrimmed)	↓-	Single-sided travel, with deadband	OFF	OFF
U-TAIL+	Elevator	↕	Up and down travels are asymmetrical	70%	70%
	Rudder	↕ 2	Right and left travels are asymmetrical, 2 directions	70%	70%
	Spoiler	↓+	Single-sided travel, with offset	OFF	OFF
	Throttle-T (untrimmed)	↓-	Single-sided travel, with deadband	OFF	OFF
AILERONS+	Aileron	↕+2	Travel is symmetrical, 2 directions, with offset	100%	100%
	Landing flaps (increase in lift)	↓+	Single-sided travel, with offset	OFF	OFF
	Spoiler (airbrake)	↕	Single-sided travel, with intermediate point	OFF	OFF
	Elevator-T (snap flap)	↕	Up and down travels are asymmetrical	OFF	OFF
FLAPS+	Landing flaps (increase in lift)	↓+	Single-sided travel, with offset	100%	OFF
	Aileron	↕ 2	Up and down travels are asymmetrical, 2 directions	50%	50%
	Spoiler (airbrake)	↕	Single-sided travel, with intermediate point	OFF	OFF
	Elevator-T (snap flap)	↕	Up and down travels are asymmetrical	OFF	OFF

3.2 Templates for helicopter models

Model templates are provided for 4 helicopter types:

- FUNCOPTER for throttle-controlled electric helicopters
- eHELI FBL for flybarless helicopters
- eHELIccPM for electric helicopters with electronic main rotor mixer
- HELIccPM for I.C. helicopters with electronic main rotor mixer
- HELImech for I.C. helicopters with mechanical main rotor mixer

Controls assignment, control function, and settings

Control function	Control	Setting	Parameter
Aileron	[Mode]	Trim ^{FP4} Step size Expo ^{FP4} D/R Travel ^{FP4}	0% 1.5% 0% 100% 100%
Elevator	[Mode]	Trim ^{FP4} Step size Expo ^{FP4} D/R Travel ^{FP4}	0% 1.5% 0% 100% 100%
Rudder	[Mode]	Trim ^{FP4} Step size Expo ^{FP4} D/R Travel ^{FP4}	0% 1.5% 0% 100% 100%
Throttle	I	Governor Trim ^{FP4} Step size Mode Expo Slow	ON ^e / OFF ^v 0% 1.5% HALF 0% 0.0s
Aux-1	---	Slow Fixed value ^{FP4}	0.0s OFF
Aux-2	---	Slow Fixed value ^{FP4}	0.0s OFF
Retract.Gear	---	Slow Fixed value ^{FP4}	0.0s OFF
Switch-1	---	-	-
Switch-2	---	-	-
Gyro	<E	Type of Gyro Heading ^{FP4} Damping /Control Suppression	Heading Control: <E OFF

Switch-3 ^e Mixture ⁱ	---	-	-
Aux-3	---	Slow Fixed value ^{FP4}	0.0s OFF
Aux-4	---	Slow Fixed value ^{FP4}	0.0s OFF
Collective	same as Throttle	Slow Fixed value ^{FP4}	0.0s OFF
Thr.Limiter	F>	Slow Fixed value ^{FP4}	0.0s OFF

^{FP4} = 4 flight phases

ⁱ = I.C. engine

^e = electric motor

All the helicopter templates contain the same set of mixers:

- four freely configurable, flight phase-enabled control mixers; e.g. to mix Aileron, Elevator, Rudder in Throttle.
- Tail rotor mixer up to 4 servos
- Main rotor mixer

Name	Mixer inputs	Settings	Value
TAIL ROTOR	Rudder, Collective	Offset Coll.+/- Coll. origin Rudd.Diff.	OFF OFF 0% OFF
MAINROTOR-R.	Rudder, Elevator, Collective	Geometry Rotation Lever +/-	90%
MAINROTOR-L.	Rudder, Elevator, Collective		0°
MAINROTOR-FB	Rudder, Elevator, Collective		0%
MAINROTOR-4	Rudder, Elevator, Collective		

3.2.1 FUNCOPTER model template

This model template is suitable for throttle-controlled helicopters with electric motor. This template cannot be adapted to the other helicopter templates as the collective pitch channel is not available.

Servo assignment

Servo	FUNCOPTER assignment
1	Aileron
2	Elevator
3	Rudder
4	Collective
5	Throttle
6	Gyro
7..16	----- (free)

3.2.2 eHeli FBL model template

In the basic configuration, this model template is optimised for helicopters with flybarless controller. The classic configuration can easily be restored by assigning tail rotor mixers and main rotor mixers on the servo side.

The template is equally suited to collective pitch-controlled electric helicopters with mechanical main rotor mixer. The "Governor" mode option is activated for Throttle. Switch off this option if you prefer to work with throttle curves (see "Throttle (helicopter)", page 124).



Servo assignment

Servo	FBL assignment	Classic assignment with mixers (restore to flybars)
1	Aileron	MAINROTOR-FB
2	Elevator	MAINROTOR-L.
3	Rudder	TAIL ROTOR
4	Collective	MAINROTOR-R.
5	Throttle	Throttle
6	Gyro	Gyro
7..16	----- (free)	

3.2.3 eHeliccpm model template

For collective pitch-controlled electric helicopters with main rotor for electronic mixing (Collective Cyclic Pitch Mixer).

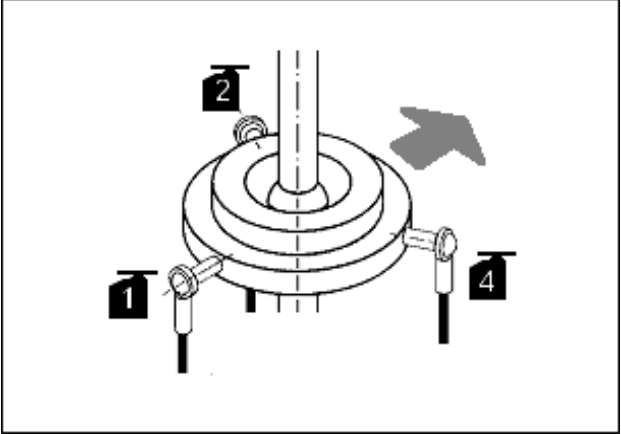
The "Governor" mode option is activated for Throttle. Switch off this option if you prefer to work with throttle curves (see "Throttle (helicopter)", page 124).

		Function
	1	MAINROTOR-FB
	2	MAINROTOR-L.
	3	TAIL ROTOR
	4	MAINROTOR-FB
5		Throttle
6		Gyro
Servo assignment for electronically mixed main rotors		

Mixer

Name	Mixer inputs	Settings	Value
TAIL ROTOR	Aileron, Collective <i>"Collective" and "Offset" are switched off if the gyro operates in Heading-hold mode.</i>	Offset ^{FP4} Coll.+ Coll.- ^{FP4} Origin Rudd.Diff. ^{FP4}	OFF OFF OFF 0% OFF
MAINROTOR-R.	Rudder, Elevator, Collective	Geometry	120%
MAINROTOR-L.	Rudder, Elevator, Collective	Rotation	0°
MAINROTOR-FB	Rudder, Elevator, Collective	Lever +/-	0%
MAINROTOR-4	Rudder, Elevator, Collective		

^{FP4} = 4 flight phases; for helicopters, the fourth flight phase is always AUTOROT (auto-rotation).

3.2.4 HELlccpm model template

For collective pitch-controlled I.C. helicopters with main rotor for electronic mixing (Collective Cyclic Pitch Mixer).

Governor mode is switched off in the throttle channel. The Switch-3 control function was replaced by Mixture for mixture configuration.

If you use a speed controller, switch on the Governor mode to deactivate the throttle curve (page 124).

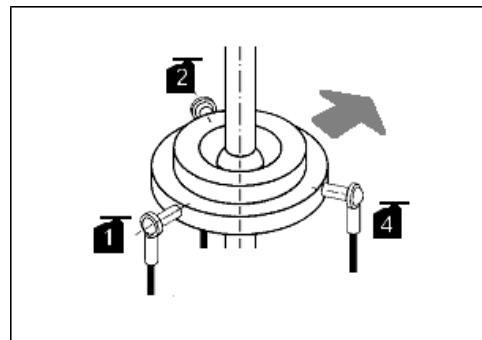

Servo assignment for electronically mixed main



Function

- 1 MAINROTOR-FB
- 2 MAINROTOR-L.
- 3 TAIL ROTOR
- 4 MAINROTOR-FB
- 5 Throttle
- 6 Gyro

Mixer

Name	Mixer inputs	Settings	Value
TAIL ROTOR	Aileron, Collective <i>"Collective" and "Offset" are switched off if the gyro operates in Heading-hold mode.</i>	Offset ^{FP4} Coll.+ Coll.- ^{FP4} Origin Rudd.Diff. ^{FP4}	OFF OFF OFF 0% OFF
MAINROTOR-R.	Rudder, Elevator, Collective	Geometry	120%
MAINROTOR-L.	Rudder, Elevator, Collective	Rotation	0°
MAINROTOR-FB	Rudder, Elevator, Collective	Lever +/-	0%
MAINROTOR-4	Rudder, Elevator, Collective		

^{FP4} = 4 flight phases; in templates for helicopters, the fourth flight phase is always AUTOROT (auto-rotation).

3.2.5 HELMech. model template

This template has been optimised for collective pitch-controlled I.C. helicopters with mechanically mixed main rotor.

Governor mode is switched off in the throttle channel. The Switch-3 control function was replaced by Mixture for mixture configuration.

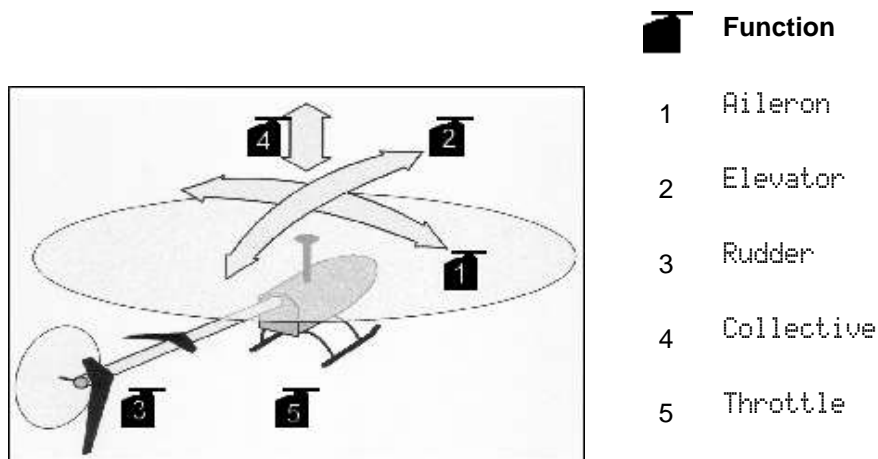

HELMech. servo assignment

Mixer

Name	Mixer inputs	Settings	Value
TAIL ROTOR	Aileron ¹ , Collective	Offset	OFF
		Coll.+	OFF
		Coll.-	OFF
		Origin	0%
		Rudd.Diff.	OFF

To convert the configured helicopter to electronic mixing, you just need to rename the Aileron, Elevator, and Collective servos to MAINROTOR-L, MAINROTOR-R, etc. in the Servo > Assign menu. The main rotor mixer is then available in the Mixer menu.

¹ "Collective" and "Offset" are switched off automatically if the gyro operates in Heading mode.

3.3 Templates for land- or water-based models and tracked vehicles

3.3.1 CAR / TRUCK model template

This model template is suitable for all types of vehicle models.

The control functions `Support Legs`, `Ramp`, `Light`, and `Aux-1` to `Aux-4` provide the `Slow` function. This allows operating support legs and ramp at a realistically slow speed. Smooth transition for `Light` is also possible.

Flight phase switching originates from model flying, as the names suggests. This function has been left activated for vehicle models. Smart modellers will have good ideas for practical application.

Control function assignments and names can be changed as required.

This template does not contain pre-defined mixers. To personalise control, 4 mixers on the control side and 7 mixers on the servo side are provided, each with eight inputs.

Controls assignment, control function, and settings

Control function	Control	Parameter	Value
Gimbal h	Horizontal stick axis. Assignment by means of controls mode.	Trim ^{FP4} Step size Expo ^{FP4} D/R Travel ^{FP4}	0% 1.5% 0% 100% 100%
Gimbal v	Vertical stick axis. Assignment by means of controls mode.	Trim ^{FP4} Step size Expo ^{FP4} D/R Travel ^{FP4}	0% 1.5% 0% 100% 100%
Steering	Horizontal stick axis. Assignment by means of controls mode.	Trim ^{FP4} Step size Expo ^{FP4} D/R Travel ^{FP4}	0% 1.5% 0% 100% 100%

Throttle	I	Trim ^{FP4} Step size Mode Expo Slow	0% 1.5% CNTR 0% 0.0s
Support Legs	---	Slow Fixed value ^{FP4}	0.0s OFF
Ramp	---	Slow Fixed value ^{FP4}	0.0s OFF
Light	---	Slow Fixed value ^{FP4}	0.0s OFF
Headlight	---	-	-
Horn	---	-	-
Gear	---	-	-
Sound	---	-	-
Aux-1	---	Slow Fixed value ^{FP4}	0.0s OFF
Aux-2	---	Slow Fixed value ^{FP4}	0.0s OFF
Aux-3	---	Slow Fixed value ^{FP4}	0.0s OFF
Aux-4	---	Slow Fixed value ^{FP4}	0.0s OFF

^{FP4} = 4 flight phases

Servo assignment

Servo	Control function / mixer	Curve points
1	Steering	3
2	Throttle	3
3 -	unused	

3.3.2 SHIP / BOAT model template

This model template is suitable for all types of water-based models.

The control functions Spoiler, Flap, Light, and Aux-1 to Aux-3 provide the Slow function. This allows operating support legs and ramp at a realistically slow speed. Smooth transition for Light is also possible.

Flight phase switching originates from model flying, as the names suggests. We left this function activated for boat / ship models. Inventive modellers will have good ideas for practical application.

Control function assignments and names can be changed as required.

This template does not contain pre-defined mixers. To personalise control, 4 mixers on the control side and 7 mixers on the servo side are provided, each with eight inputs.

Controls assignment, control function, and settings

Control function	Control	Setting	Parameter
Gimbal h	Horizontal stick axis. Assignment by means of controls mode.	Trim ^{FP4} Step size Expo ^{FP4} D/R Travel ^{FP4}	0% 1.5% 0% 100% 100%
Gimbal v	Vertical stick axis. Assignment by means of controls mode.	Trim ^{FP4} Step size Expo ^{FP4} D/R Travel ^{FP4}	0% 1.5% 0% 100% 100%
Rudder	Horizontal stick axis. Assignment by means of controls mode.	Trim ^{FP4} Step size Expo ^{FP4} D/R Travel ^{FP4}	0% 1.5% 0% 100% 100%
Throttle	I	Trim ^{FP4} Step size	0% 1.5%

Control function	Control	Setting	Parameter
		Mode Expo Slow	HALF 0% 0.0s
Flap	---	Slow Fixed value ^{FP4}	0.0s OFF
Spoiler	---	Slow Fixed value ^{FP4}	0.0s OFF
Light	---	Slow Fixed value ^{FP4}	0.0s OFF
Headlight	---	-	-
Horn	---	-	-
Gear	---	-	-
Sound	---	-	-
Mixture	---	Slow Fixed value ^{FP4}	0.0s OFF
Aux-1	---	Slow Fixed value ^{FP4}	0.0s OFF
Aux-2	---	Slow Fixed value ^{FP4}	0.0s OFF
Aux-3	---	Slow Fixed value ^{FP4}	0.0s OFF

^{FP4} = 4 flight phases

Servo assignment

Servo	Control function / mixer	Curve points
1	Rudder	3
2	Throttle	3
3 - 16	not assigned	

3.3.3 TRACKED V. model template

This model template is suitable for tracked vehicles.

Control function assignments and names can be changed as required.

Completed tracked vehicle models typically contain a functional building block that combines "Throttle" and "Steering" for the two power systems.

If you are using 2 separate speed controllers, it is recommended to change the servo assignment for `Steering` and `Throttle` to TRACK+ (page 149).

TRACK+ stands for a mixer that combines "Throttle" and "Steering". You configure the required settings in the Σ Mixer menu (page 132).

Set a small deadband value in the mixer for `Steering`. If "Steering" and "Throttle" are assigned to the same stick unit, opening the throttle often involves a small steering movement. Applying a deadband to "Steering" solves this problem.

To personalise control, 4 mixers on the control side and 6 mixers on the servo side are provided, each with eight inputs.

Controls assignment, control function, and settings

Control function	Control	Setting	Parameter
Turret turn	Horizontal stick axis. Assignment by means of controls mode.	Trim ^{FP4} Step size Expo ^{FP4} D/R Travel ^{FP4}	0% 1.5% 0% 100% 100%
Gun up/down	Vertical stick axis. Assignment by means of controls mode.	Trim ^{FP4} Step size Expo ^{FP4} D/R Travel ^{FP4}	0% 1.5% 0% 100% 100%
Steering	Horizontal stick axis. Assignment by means of controls mode.	Trim ^{FP4} Step size Expo ^{FP4} D/R Travel ^{FP4}	0% 1.5% 0% 100% 100%
Throttle	I	Trim ^{FP4} Step size Mode Expo Slow	0% 1.5% CNTR 0% 0.0s
Weapon sel.	---	Slow Fixed value ^{FP4}	0.0s OFF
Gear	---	Slow Fixed value ^{FP4}	0.0s OFF

Aux-1	---	Slow Fixed value ^{FP4}	0.0s OFF
Light	---	-	-
Headlight	---	-	-
Gyro	---	Type of Gyro Damping/Heading ^{FP4} /Control Suppression	Heading --- OFF
Horn	---	-	-
Aux-2	---	Slow Fixed value ^{FP4}	0.0s OFF
Aux-3	---	Slow Fixed value ^{FP4}	0.0s OFF
Aux-4	---	Slow Fixed value ^{FP4}	0.0s OFF
Aux-5	---	Slow Fixed value ^{FP4}	0.0s OFF

^{FP4} = 4 flight phases

Servo assignment

Servo	Control function / mixer	Curve point
1	Steering optional TRACK+	3
2	Throttle optional TRACK+	2
3	Turret turn	3
4	Gun up/down	3
5	Weapon sel.	3
6 - 16	unused	

Mixer

Name	Mixer inputs	Options & settings	Value	
TRACK+	Steering	±2 Travel is symmetrical, 2 directions, with deadband	50%	50%
	Throttle	± Forward and backward travels are asymmetrical	OFF	OFF

MULTIPLEX Modellsport GmbH & Co.KG • Westliche Gewerbestraße 1 • Bretten • Germany

©MULTIPLEX 2014 • Printed in Germany

www.multiplex-rc.de

4 The menus

The **PROFI TX** software is divided into status displays and menus that are structured in several levels.

4.1 Status displays

The 8 status displays provide information about transmitter, model and sensors. The status display is shown after transmitter startup or when exiting the main menus.

Press the **+** or **-** buttons or use the central wheel to toggle between screens. Every clockwise increment on the central wheel cycles to the next status display (see also section 5 "Operating the transmitter" on page 164).

Status display #2 is always active when the device is switched on or when a different memory is selected.

4.1.1 Status display #1

Turn the wheel to the left. Status display #1 provides an overview of the current battery and device status:

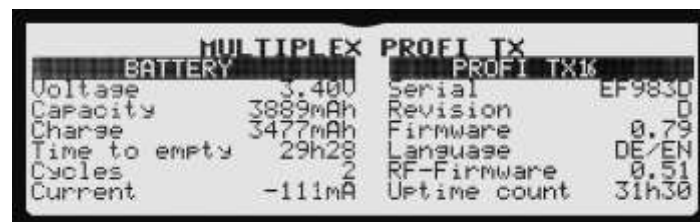

MULTIPLEX		PROFI TX	
BATTERY		PROFI TX16	
Voltage	3.400	Serial	EF9830
Capacity	3889mAh	Revision	0
Charge	3477mAh	Firmware	0.79
Time to empty	29h28	Language	DE/EN
Cycles	2	RF-Firmware	0.51
Current	-111mA	Uptime count	31h30

- The device name is shown in the first line. The text can be edited (menu: Setup > Transmitter > User data > Name parameter, see section 4.3.9 "Transmitter" on page 114).
- The left half of the screen provides information about the battery, e.g. battery voltage, remaining operating time (time to empty), etc.
- The right half of the table provides information about the device, e.g. serial number, total uptime count, etc.

4.1.2 Status display #2

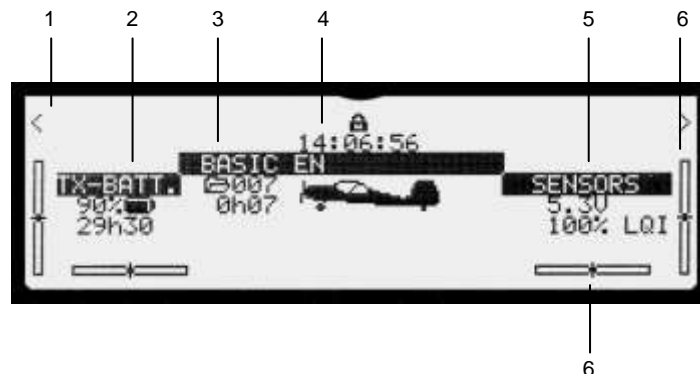

1 Digi-adjuster

Set values and their names, which can be edited using the retro-fittable digi-adjusters.

The padlock icon in the centre opens when the values are enabled for editing (see section 5.3 "Digi-adjuster" on page 168).

2 Battery status

- TX-BATT. (TX is short for "transmitter")
- Battery charge of the transmitter
- Remaining operating time.

These displays start to flash when the remaining operating time (time to empty) reaches the set alarm time (menu: Setup > Transmitter > Battery alarm parameter, see section 4.3.9 "Transmitter" on page 114). From then on, the remaining operating time (time to empty) is announced. Towards the end, the predicted operating time reduce quickly since additional power is consumed by the announcements. For this reason, we have included a small buffer.

3 Model memories

- Name of the model memory (inverted as heading)
- Below the name: model memory number, uptime count for the model and the respective ID number, if an ID receiver is used.
- Next to the name: icon for the type of model used

- 4 Current time. An asterisk next to the time indicates that the alarm clock function is activated.

The following warnings are displayed in capital letters.

MEMORY ERROR!	Displayed when errors occur while loading a model memory. (page 163)
RANGE!	Transmitting power is reduced for the range check. (page 95)
RF ERROR!	The RF component is defective.
STUDENT MODE!	The Student mode is enabled.
STUDENT	Only in Teacher mode: The selected control functions are transferred to the student.
MULTIFLIGHT	A MULTIFlight stick was detected: The mixers on the servo side are switched off.

- 5 Sensor display on status display #2

Displays the values for sensors 0, 1, and 15 if a receiver with downlink is used. The value is shown crossed out if no sensor signal is received for several seconds.

If the sensor reports an alarm:

- The sensor value starts to flash.
- The appropriate warning light for the sensor group below the screen starts to flash (see section 2.1.1 "Top view" on page 23).
- The device also starts to vibrate if the vibration alarm is activated (see section 4.3.5.2 "Announce & Alert" on page 103).

*If the sensor clears the alarm the value stops flashing. The vibration alarm and warning light remain active until they are cleared by pressing the **ENTER** button.*

Notice: In other status displays the ENTER button has different functions.

6 Trim display

Trim settings for the 4 stick axes. The trim display can be customised in the Setup > Transmitter menu.

4.1.3 Status display #3

Status display #3 provides an overview of the timers (see section 4.7 "Timer main menu" on page 152). The other elements are identical to status display #2.

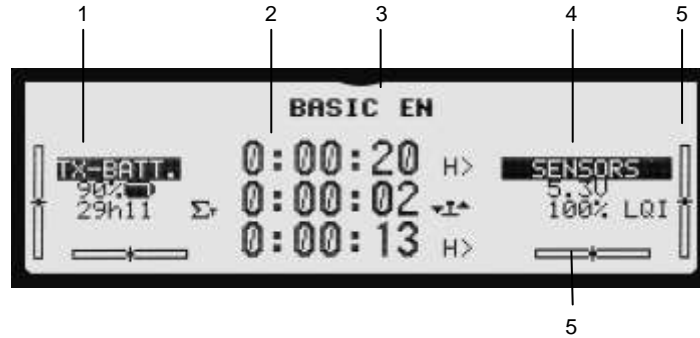

- 1 Battery status (see section 4.1.2 "Status display #2" on page 88)
- 2 Timers:
 - Counting direction of the respective timer
 - Indication of the timer type
 - Assigned switch
- 3 Name of the model memory or status of the digi-adjusters, if used (see section 4.1.2 "Status display #2" on page 88)
- 4 Values for the sensor addresses 0, 1, and 15 (see section 4.1.2 "Status display #2" on page 88)
- 5 Trim display (see section 4.1.2 "Status display #2" on page 88).

Pressing the **REV/CLR** button in status display #3 resets all timers.

4.1.4 Status displays #4 to #8

The status displays #4 to #8 show three sensor values each.

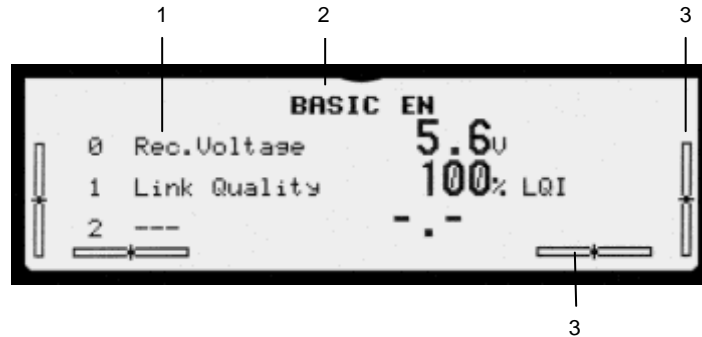

1 Sensors:

- Sensor address
- Sensor name
- Sensor value
- Unit

The inverted display of a line indicates that the sensor reports an alarm.

The value is shown crossed out if no sensor signal is received for several seconds.

The minimum / maximum values are displayed while pressing and holding the **ENTER** button. This is only possible if a receiver with downlink provides data to display!

2 Alternative:

- Status of the digi-adjusters, if used (see section 4.1.2 "Status display #2" on page 88).
- Name of the model memory, if no digi-adjuster is assigned.

3 Trim display (see section 4.1.2 "Status display #2" on page 88).

All minimum / maximum memories are erased when you press the **REV/CLR** button in the status displays #4 to #8.

4.2 Menu structure

The **PROFI TX** menus are structured in several levels:

- Main menu
The 6 main menus are opened via the 6 direct menu access buttons (see section 5.1.1 "Menu buttons" on page 164).
The main menus only provide links leading to the menus themselves.
Each link is always indicated by a succeeding series of 4 full stops.
- Menu
The menu can contain both links to sub-menus and parameters.
- Sub-menu
The sub-menus only contain parameters.
- Parameter
Parameters are set values which appear in menus and sub-menus. Some only provide information, but others can be edited.
Uneditable parameters are skipped when browsing.

Navigation in the menus

You can use the buttons or the central wheel to navigate through the menus:

1. Press one of the direct access buttons to open the respective main menu.
2. Use the central wheel or press the **+** or **-** buttons to select a menu item.
3. Press the wheel or the **ENTER** button to access the respective sub-menu.
4. Press the wheel or the **ENTER** button to move to an input field.

Refer to section 5 "Operating the transmitter" on page 164 for detailed information on how to navigate in menus and enter values.



An **▼** or **▲** arrow on the left edge indicates that the menu contains more lines than can be displayed on screen.

Continue to browse using the central wheel or the **+ / -** buttons to scroll to the top or end of the list.

4.3 Setup main menu

Overview

Volume		Volume control
M-LINK		Binding, Failsafe, etc.
Flight phases		Enabling flight phases, names, transition
Training		Training mode
Sensors	Vario. & Altitude	Settings for variometer and altitude announcements
	Announce & Alert	Vibration alarm, announcements, announcement interval
	Edit name	Entering and editing sensor names
Assign.Controls		Mode (stick assignment), names, assignment
Assign.Switches	TriggerPoint	Trigger points of the proportional controls
	MagicSwitch	Logical combination of switches
	Assignments	Which switch switches which function?
Define mixer		
Transmitter	Sounds	Switching off specific sounds and announcements
	Miscellaneous settings	Battery alarm, Contrast, etc.
User data		PIN, name of the owner, language

Opening the menu

To open the main menu: Button



4.3.1 Volume

The general volume and the volume of the variometer tone are configured separately.

The figure below illustrates the default configuration of a newly created model memory. The following options are available:

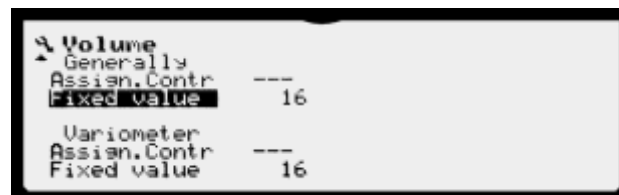

- Assign.Contr.: You can use any freely assignable control as volume actuator. This also includes virtual switches (MagicSwitch and flight phases). The assigned control is used when the fixed value is set to OFF.
- Fixed value: The setting range is OFF to 25. The default setting is 16. When OFF is selected, volume control is transferred to the assigned control. If no control is assigned the device remains muted.

Special features:

- General volume: When the volume is switched on using a control, the announcement sequence of the sensor data is restarted.
- Variometer tone: When the volume is switched on using a control, the altitude is announced once.
- **PROFI TX 16** only: Servo 16 can be used as volume actuator. Complex volume control scenarios can be implemented using mixers, e.g. the variometer tone can be muted when pushing/pulling and opening the throttle.

4.3.2 M-LINK

The radio link functions are set in the M-LINK menu.



Range check

When performing a range check, the transmitting power is significantly reduced to allow shorter distances between transmitter and model (see section 2.6 "Range check" on page 46).

Set Failsafe

The current servo positions are stored in the receiver.

If Failsafe positions were stored in the receiver, the servos return to these positions after 0.5 seconds.

- Use the respective **PROFI TX** controls to move the servos (control surfaces) of your model to the desired positions.
- Set the value to **ON**. After a few moments, it reverts to **OFF**.
- Check the Failsafe function by switching the transmitter off.

FastResponse

FastResponse reduces the transmission cycle from 21ms to 14ms. This reduces the response time for control commands. Only 12 servos can be controlled when FastResponse is active.

NOTICE

Not all servos work properly with FastResponse. Incompatible servos may vibrate excessively in idle position. Check your servo before starting off on the first flight.

FastResponse has a noticeable effect only on extremely agile models that are equipped with ultra-fast servos.

Binding

- Activates the binding procedure and displays the current binding status (see section "Binding" on page 47).

RX-ID: The binding procedure is completed. If the receiver has an ID, this ID number is displayed.

seeking.. The device is locating the receiver, the binding procedure is in progress.

4.3.3 Flight phases

It is useful to have different settings and trims for specific flight phases when flying models. The flight phases technology in the **PROFI TX** provides an easy and convenient way to realize this. You can copy settings for one flight phase to another, disable flight phases if they are not needed, assign switches to flight phases, etc.

After switching to a different flight phase, the name of the new flight phase is announced. If the flight phase is disabled, the flight phase is not switched. The operator is alerted of the disabled flight phase by an announcement.

Refer to section 7.2.10 "Working with flight phases" on page 205 for information on how to work with flight phases, assign switches to flight phases, disable / enable flight phases, etc.

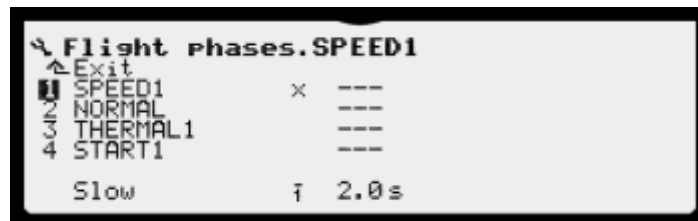

Flight phase number (1, 2, 3, or 4)

Identifies the flight phase in other menus. In the control function menus, all settings that can differ between flight phases are accompanied by the respective identifying number 1 to 4 for the flight phase.

Flight phase name (e.g. SPEED1)

You can select the designations for the flight phases from a list of 13 pre-set names (see section 7.2.10.5 "Changing flight phase names" on page 207).

After activating the input field for the name, select a suitable name by pressing the + / - buttons or by using the central wheel.

Disabled flight phases are shown crossed out.

×

Identifies the active flight phase.

Switch (e.g. 1 >)

Switch that is assigned to the flight phase; the arrow indicates if the left (<) or right (>) switch is associated.

Three dashes "---" indicate that no switch has been assigned for switching between flight phases.

Slow

Transition time to the next flight phase.

Switching flight phases may involve major surface position changes. Sudden major changes e.g. to camber-changing flaps or airbrakes make controlling the model difficult and lead to undesired, hard transitions to the next flight phase.

These problems do not occur when the transition is performed slowly. The transition is automatically calculated in such a way that all servos move to their new positions in a synchronized manner and within the selected time frame.

The control commands by the pilot are not slowed down.

Possible range: 0.1 to 6.0 seconds

Pressing REV/CLR

Disables or enables the selected flight phase.

4.3.4 Training (principle)

In trainer mode (teacher / student), a wireless connection is established between two Multiplex transmitters via M-LINK.

The teacher transmitter controls the model and must be bound to the model (binding procedure). The student transmitter transmits the stick signals to the teacher transmitter via M-LINK. The teacher can transfer a freely definable group of control signals to the student.

The teacher transmitter requires a receiving device for the student signal. On older transmitters with DIN socket, the trainer stick is the receiving device; the **PROFI TX** uses the COPILOT module.

The trainer stick or the COPILOT module are bound in the same way to the student transmitter (binding procedure) as receivers.

4.3.4.1 Student mode

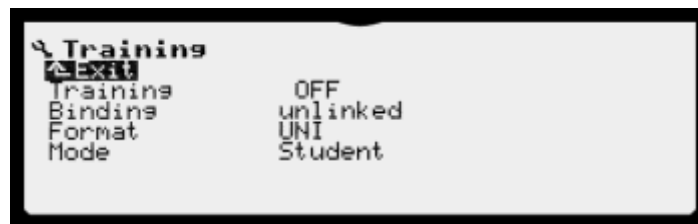

- Set Training to ON. This activates the training system.
- Set "Format" to MPX if the teacher uses an older Multiplex transmitter that does not support the UNI format.
- Set Mode to Student.
- Now, the student transmitter must be bound to the receiving device of the teacher transmitter. For this, "Binding" must be activated on both sides.
 - Activate "Binding": The display changes to `seeking..`
 - Now, activate "Binding" on the receiving device of the teacher transmitter. Place the front of the **PROFI TX** close to the receiving device of the teacher transmitter.
 - After a few moments, the "Binding" display changes from `seeking..` to `Teacher`.

This indicates that the radio link to the receiving device of the teacher transmitter has been established.

The message `STUDENT MODE` flashes on the status displays #2 to #8 while the Student mode is active.

NOTICE

Both transmitters must use the same `Format` setting; otherwise, the centre positions of the control signals will differ.

Remember to set "Training" to `OFF` if you wish to control the model directly.

4.3.4.2 Teacher mode

For Teacher mode, a COPILOT module and an assigned switch are required (see section 2.7 "Trainer mode" on page 49).

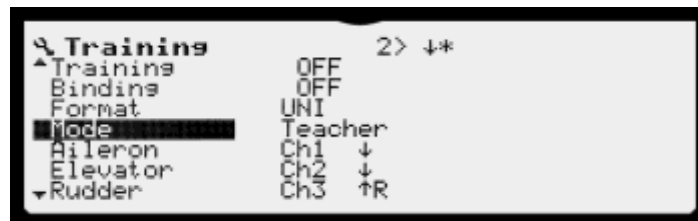

- Set "Training" to `ON`. This activates the training system. In Teacher mode, the COPILOT module is switched on. This increases the power consumption considerably.
 - Choose the same servo format setting as on the student transmitter. Otherwise, the neutral positions of the servos will not match.
 - Set the `Mode` menu item to `Teacher`. This switches the COPILOT module on. The power consumption increases by 40mA. Now, 7 control functions are displayed below, which can be transferred to the student individually or in groups.
 - Activate "Binding" on the student transmitter.
 - Open the "Binding" menu item and turn the wheel by one clockwise increment. The display changes from `OFF` to `seeking..`. The COPILOT module is now bound to the student transmitter. After a few seconds, the display should change from `seeking..` via `OFF` to `Student`. If this is not the case, hold the **PROFI TX** over the aerial of the student transmitter (the COPILOT module is positioned below).
 - The following elevator example illustrates how control functions are assigned to the student.
 - Open the "Elevator" menu item.
 - Operate the elevator stick on the student transmitter vigorously.
-

- The servo channel used by the student transmitter for transmitting the elevator signal is displayed next to Elevator, usually Ch2.
- Check on the model if the rotation direction of the student signal is correct. You can reverse the direction by pressing the REV/CLR button.

⚠ CAUTION

Make sure that the model motor cannot start up!

- Close the menu item.
- Repeat these steps to assign all control functions that the student is allowed to control.
- If the teacher switch is switched on and the connection to the student transmitter is established, the student controls the assigned control functions.

Important information:

- If the control functions are transferred to the student, the message `STUDENT CONTROLS` flashes on the status displays #2 to #8. Upon transfer of the control functions, the speech output announces: "student controls".
- If the connection to the student transmitter is lost, all control functions are returned to the teacher. The speech output announces: "student offline".
- "Binding" can be switched off by rotating the wheel to the left while the menu item is open.

NOTICE

Switch OFF the training system if it is not needed any longer.

Otherwise, the student may inadvertently re-establish the student connection in Teacher mode by switching on the transmitter and take control of your model. Besides, the power consumption of the COPILOT module reduces the operating time significantly.

In Student mode, trim is switched off as long as the training system is switched on.

4.3.5 Sensors



You can use the `Sensors` menu to define or edit sensor names, to configure the setting and sensor address of the variometer and to switch the vibration alarm on or off.

4.3.5.1 Vario. & Altitude

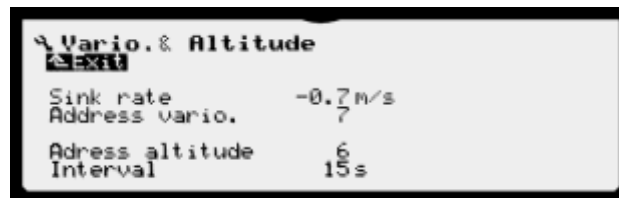

Sink rate

Here, you set the optimum sink rate for your model.

Possible range: -0.1 m/s to -2.0 m/s

How the variometer tones change from climbing to descending is adjusted accordingly:

Climbing

High tone; pitch and interval frequency increase proportionally with the climb rate.

Descending

Low tone (hum);

- From "0 m/s" to "Sink rate": pitch and interval frequency are proportional to the climb rate.
- Below sink rate: continuous low tone without interval.
- From "-3 m/s": no tone.

The menus

Address vario.

Sensor address of the variometer.

Address altitude

Sensor address of the altitude sensor.

Interval

- OFF: The altitude is announced "by grid". The grid adjusts to the altitude: Up to an altitude of 100m the grid spacing is 25m, up to 300m it is 50m, and above it is 100m.
- 4 30s: The altitude is announced at the set intervals.



The altitude announcement can be configured as switchable in the **Setup > Assign.Switches** by assigning a switch.

4.3.5.2 Announce & Alert

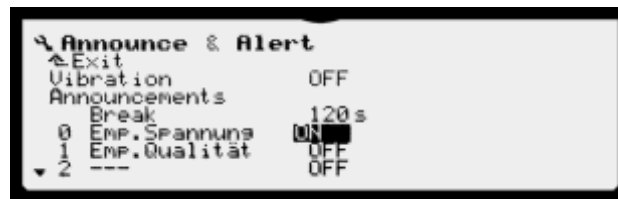

Vibration

Activates/deactivates device vibration to report sensor alarms.

Announcements

Speech output can be generated for the sensor values. This option can be activated for each sensor individually. Please note that the announcement for a single sensor takes several seconds. For 16 sensors, the complete announcement sequence can take up to one minute. For this reason, announcements should only be activated for important sensors.

Sensors that trigger alarms are always announced even if they are not activated.

Break

The break interval between two announcement sequences can be set to a value between 30s and 180s.

Sensor 0 to sensor 15

Here, you activate the announcement for each sensor individually.

4.3.5.3 Edit name



Here, you specify suitable names for the sensors:

1. Select a name or an empty line.
2. Confirm your selection. The sub-menu is opened.
3. Enter a name or edit the name as desired (see section 5.1.3 "Text input" on page 166).
4. Confirm your input.

4.3.6 Assign.Controls

You can use the `Assign.Controls` menu to assign controls (actuators) to control functions, set the actuation direction, and define or edit the name of control functions.



Mode

The controls mode defines how the main control functions are assigned to the sticks (see section "Controls mode" on page 172).

Edit name

You can customise the names of the control functions as needed for your model:

- Select a name or an empty line.
- Confirm your selection. The sub-menu is opened.
- Enter a name or edit the name as desired (see section 5.1.3 "Text input" on page 166).
- Confirm your input.

List of control functions to which controls can be assigned as desired. The control functions "Aileron", "Rudder", and "Elevator" are not included in this list as they are assigned to the sticks using the controls mode.

- Refer to section "Control functions of the model templates" on page 172 for a list of the control functions.
- The freely assignable controls are listed on page 171.

To assign a control function proceed as follows:

- Open the desired input field.
- Assign a control by pressing the + / - buttons, by using the central wheel or by operating the control.
- To set the actuation direction keep the control in the desired zero position and close the input field. Alternatively, you can invert or erase the input by pressing the **REV/CLR** button, if required.

4.3.7 Assign.Switches

You can use the **Assign.Switches** menu to assign the controls to switched functions, set the actuation direction, and configure the control switch and MagicSwitch.

Overview

Assign.Switches	
TriggerPoint	Upper / lower trigger points of the controls: I, E to H
MagicSwitch	4 MagicSwitches
Assignment list	3x Dual-Rate Combi-Switch Throttle-Cut 3x Timer Teacher Phases 1-3 Phase 4 Vibration (OFF) Altimeter



4.3.7.1 **TriggerPoint**

All controls can be assigned as switches except for the stick axes that are assigned to aileron, elevator, and rudder. You can use the `TriggerPoint` sub-menu to set the switching thresholds for the unassigned stick axis `↔` and for the 4 sliders. The switching thresholds for the other controls cannot be configured. They are permanently set to +/- 95%.

The upper and lower switching thresholds are configured separately. When the control is positioned between the switching thresholds this position corresponds to the centre position of a 3-position switch. The control centre is zero. Negative values are below, positive values above.

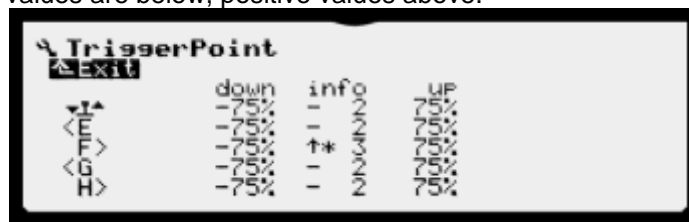

`down / UP`

Upper or lower switching threshold. For values above the switching thresholds the switch is ON, for values in between them it is always OFF.

`info`

Indicates the mode of operation of a switch that is derived from these controls.

Example - control F>:

- Move the slider to the centre position: "(-)" is shown under `info`. That means that the switched state is OFF.
- Move the control slowly upwards. The display under `info` changes to `↑*`. The switch has reached its upper ON position.
- Raise the switching threshold. Can you see what happens? When you raise the switching threshold the arrow and the asterisk disappear. The switched state returns to OFF. Restore the previous switching threshold: Arrow and asterisk are displayed again: The switched state returns to ON.

The number indicates the flight phase that would be active in this position, provided that this control is used as a flight phase switch. Which side of the switch switches on the respective function is defined when you assign the switch, not any earlier.

`↔, E, F, G, H`

Sticks and sliders for which the switching thresholds are set. The arrow points to the side on which the control is installed: left (`<`) or right (`>`).

To set a switching threshold proceed as follows:

1. Select the desired control.
2. Open the down switching threshold.
3. Adjust the value by pressing the + or - buttons or using the central wheel.
4. Open the up switching threshold.
5. Adjust the value.

4.3.7.2 **MagicSwitch**

You can use the MagicSwitch sub-menu to change the configuration and settings for the 4 MagicSwitches MS1 to MS4 (see section "MagicSwitch" on page 175).

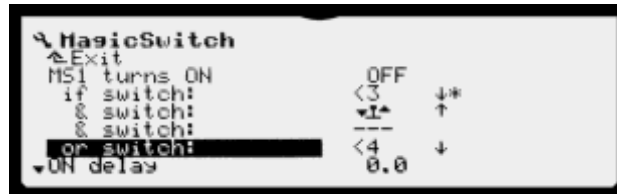

The following settings are available:

if / & switch

Assignment of switches that are combined by AND; i.e. the MagicSwitch is "ON" when all of the switches assigned here are ON.

or switch

Assignment of a switch that is combined by OR. The MagicSwitch is ON when either this switch is ON or when all of the switches that are combined by AND are ON.

ON delay, OFF delay

Delay time for switching the MagicSwitch output; OFF and ON delay are configured separately.

To assign a MagicSwitch proceed as follows:

1. Open the desired input field.
2. Assign the desired switch using the central wheel.
3. Set the switch to the ON position or select it using the **REV/CLR** button.
4. Close the input field.

MS3 and MS4 were added in version 2. For reasons of backward compatibility, the additional MagicSwitches were added at the end of the list of switches.

4.3.7.3 **Switch**

The following parameters in the menu indicate the switchable functions provided in the software. Refer to section 5.4.2 "Assign.Switches" on page 173 for the list of functions.

To assign a control function proceed as follows:

1. Open the desired input field.
2. Assign the desired switch by operating it. Other MagicSwitches (MS1.. MS4) and the flight phases (FP1.. FP4) cannot be assigned by operating them. The wheel must be used to do so.
3. Set the switch to the ON position or select it using the **REV/CLR** button.
4. Close the input field.

4.3.8 Define mixer

You can use the `Define mixer` menu to define how the mixers on the servo side are construed. The parameters are configured in the `Mixer` menu (see section 4.5 "Mixer main menu" on page 132).

The mixer definition determines the structural design of the mixer. Each mixer can combine up to eight control functions (mixer inputs). A switch can be assigned to every input. The mixing method is defined using options.

The number of mixers depends on the model template selected. Helicopters have 2 of these mixers, while all other models have 7. Depending on the template, several mixers may be pre-defined with meaningful names. These names are used to assign the mixer outputs to the servos.

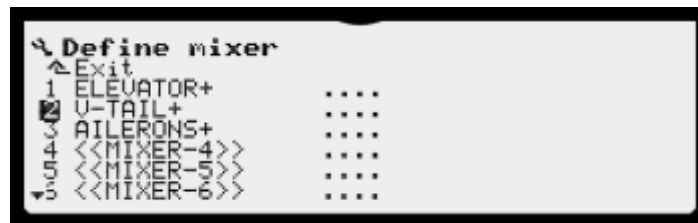

Each mixer has the following sub-menu:

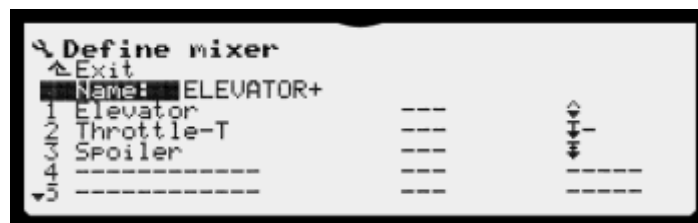

4.3.8.1 Name

The `Name` parameter shows the name of the mixer.

You can enter a new name or edit the name as desired (see section 5.1.3 "Text input" on page 166).

4.3.8.2 Mixer inputs

The name of the mixer is followed by eight numbered lines with three input fields each.

Control function (mixer input)

You select the mixer input in the first field simply by operating the desired control function. Naturally, this only works if the control (actuator) has a control function assigned. Alternatively, you can use the + / - buttons or the central wheel to select a control function as mixer input.



Switching input

In the second field the mixer input can be configured as switchable. To do this, simply operate the desired switch. The ON position is the switch position upon exiting the input field. The arrow next to the switch name points in the direction of the ON position (↗ or ↘). When the switch is switched on an asterisk "*" appears next to the arrow.

Alternatively, you can assign the switch using the + / - buttons or the central wheel. The switch can be reversed by pressing the REV/CLR button.

Mixer option

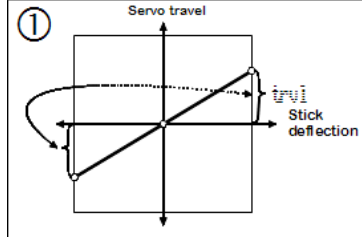
8 options are available for adapting the mixing method. The options are represented by icons:

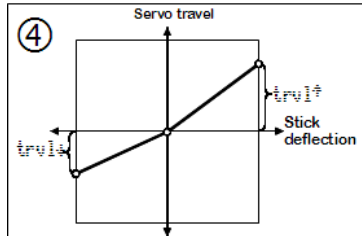
Icon	Effect	Figure
	<p>Symmetrical option: The neutral position of the control function is in the centre (aileron, elevator, rudder). The control travels on both sides of the neutral position are identical.</p>	
	<p>Bilateral option: The neutral position of the control function is in the centre (aileron, elevator, rudder). The travels on both sides of the neutral position can be configured separately.</p>	

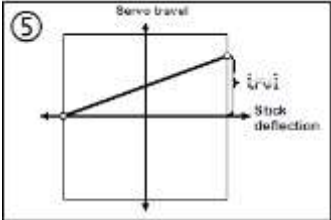

- ↓ Single-sided option: The neutral position is located on one side (end-point) of the control. The end-travel is set.

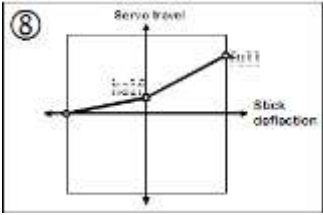

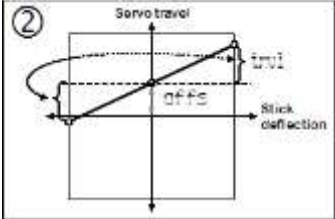
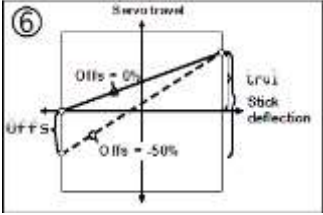
- ⌘ 3P option: The neutral position is located on one side (end-point) of the control. The control travel is set at half and at full travel.

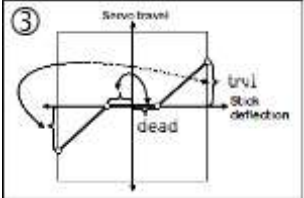
- 2 Toggle option: The input control function (usually aileron) changes direction (is toggled) upon each assignment of this mixer to a servo. Example: The aileron moves up on one wing panel and down on the other. This option can be combined with ⌘, ⌘, and ⌘.
- + Offset option: An offset shifts the origin of the mixer to one side. Example: The ailerons are raised as spoilers. The travel distance up (spoiler) is long, the travel distance down of the aileron is short. Part of the servo travel remains unused. The offset is used to shift the neutral position of the mixer down. This option can be combined with ⌘ and ⌘.



- Deadband option: Mixing does not start immediately at the neutral position, but after the control has passed the set deadband.

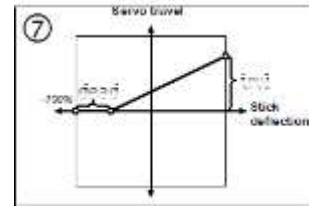













The option can be combined with  and .



Cu Curve option: The input passes through a 7-point curve. You can choose from 8 curves. The same curve can be used for multiple inputs in different mixers.

When scrolling through the 3rd column of the mixer definition you will see any combination of the icons described above in the following order:

Icon	Effect
	Symmetrical, for surface pairs moving in opposite directions
	Symmetrical, for surface pairs moving in opposite directions with offset
	Symmetrical, with offset
	Symmetrical, for surface pairs moving in opposite directions with deadband
	Symmetrical, with deadband
	Symmetrical
	Asymmetrical
	Asymmetrical, for surface pairs moving in opposite directions
	Single-sided
	Single-sided, with offset
	Single-sided, with deadband
	Single-sided, with additional set point at half travel
Cu1 to Cu8	Curve mixer: The mixer input passes through one of 8 control curves.
Cu1 2 to Cu8 2	Curve mixer for surface pairs moving in opposite directions.

4.3.9 Transmitter

You can use the Transmitter menu to configure transmitter-related settings. You can activate some audible signals, set the battery alarm threshold, define the contrast, etc.



The settings in this sub-menu only apply to the transmitter. They are not stored in the respective active model memory on the SD card, but in a dedicated memory area.

4.3.9.1 Sounds

Various announcements and sounds can be switched on or off in this sub-menu.



- Startup: A tune is played when the device is switched on.
- Trim values: The trim position is announced after the trim lever is released.
- Safety Check: Voice prompt to perform the safety check.

4.3.9.2 Battery alarm

Remaining operating time (time to empty) at which the device starts to issue audible warnings. A spoken warning is issued. The expected remaining operating time (in minutes) is announced.

Possible values: 20 to 60 minutes

Factory setting: 60 minutes



The announcement interval reduces with decreasing remaining operating time (time to empty). To save power, a shortened announcement is issued in the last minutes. Please note that several charge/discharge cycles are required before the remaining operating time (time to empty) can be determined accurately.

The menus

4.3.9.3 Contrast

Optimise the contrast.
Possible values: +8 to -8
Factory setting: 0

4.3.9.4 Trim graph

Trim graph The 6 trim display designs.

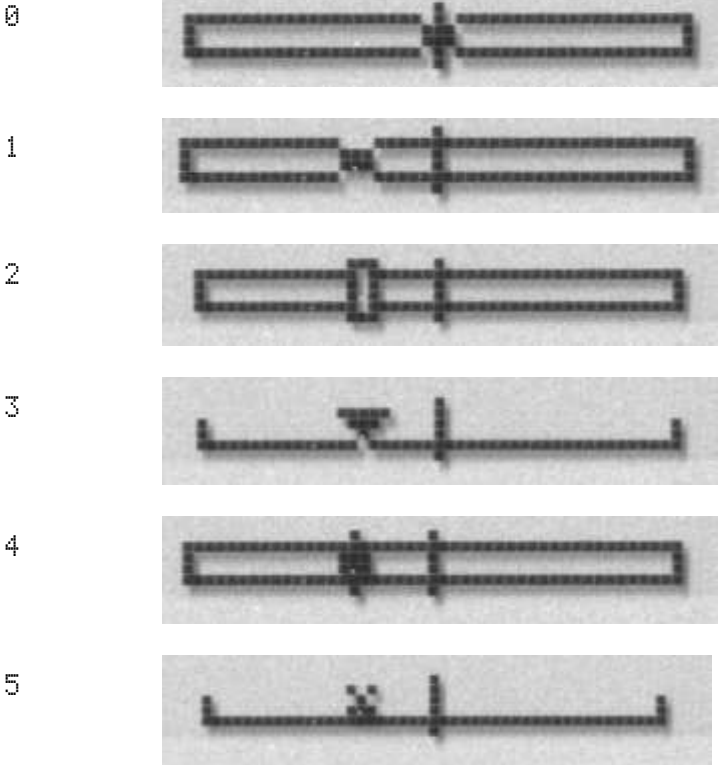
**4.3.9.5 Menu direction**

Direction of menu navigation (see section 5 "Operating the transmitter" on page 164).

4.3.10 User data



Personal data, the PIN for disabling data entry, the menu language and free text (max. 32 characters) can be configured in this menu to customise the transmitter according to your needs.

4.3.10.1 PIN

Any PIN entry that differs from the pre-set value 0000 activates the code lock. Entering 0000 deactivates the lock.

When the code lock is active the user is prompted for the PIN before an input field is opened. The PIN is entered via the buttons on the keypad. The PIN must be known in order to be able to change any settings.

If you have forgotten the PIN the code lock cannot be deactivated: Please contact one of our Service Centres.



After PIN entry, the code lock is activated when the device is switched on again.

- With active code lock, the user is prompted for the PIN when opening an input field.
 - Upon entry of the correct PIN, all input fields remain enabled until the device is switched off again.
 - If the wrong PIN is entered the input fields remain disabled. The PIN prompt is displayed every time you try to open an input field.
-

4.3.10.2 Language

Used for changing menu language and speech output.

The PROFI TX uses language pairs: always English and an alternative language (German, French).

- You can use the update function to change the language pair (see section 6.3 "Software update" on page 178).
 - Any user-editable text (names of models, control functions, mixers, timers) remain unchanged in the language they were created.
 - New model memories are created in the new language.
-

4.3.10.3 Name

Any text, e.g. the name of your device; this text is shown in status display #1 in line 1 (see page 87).

Max. length: 32 characters.

Refer to section 5.1.3 "Text input" on page 166 for details.

4.4 ControlFunctions main menu

You can use this menu to adjust the settings for control functions, e.g. trims, travels, control curves, etc.

The menu is dynamic:

- It lists only the control functions that are actually used, i.e. the control function must control at least one servo directly using mixers.
- The menu content differs for vehicle models, fixed-wing models, and helicopter models.
- Control functions that do not have configurable parameters are not shown (Wheel Brake, Mixture, Towing dog).

Refer to section "Control functions of the model templates" on page 172 for a list of the control functions offered by the **PROFI TX** model templates.

Overview of controls functions - fixed-wing models

Aileron	
Elevator	Trim Step size, Expo ^{FP} , D/R, Travel ^{FP}
Rudder	
Throttle	Trim: Step size & Mode, Expo, Run-up Time
Flap	
Spoiler	
Retract.Gear	
Aux-1	Slow, Fixed value ^{FP}
Aux-2	
Aux-3	
Aux-4	
Gyro	Type of Gyro, Fixval. Sense ^{FP} , Suppression, controlled Axis

^{FP} = with flight phase switching

Overview of controls functions - helicopters

Aileron	
Elevator	Trim Step size, Expo ^{FP} , D/R, Travel ^{FP}
Rudder	
Throttle	
Thr.Limiter	Run-up Time (Slow)
Retract.Gear	
Aux-1	Slow, Fixed value ^{FP}
Aux-2	
Aux-3	
Aux-4	
Gyro	Type of Gyro, Fixval. Sense ^{FP} , Suppression, controlled Axis

^{FP} = with flight phase switching

Opening the menu

To open the main menu: Button 

Fixed-wing models:

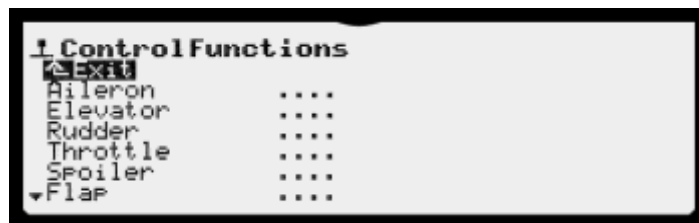

Helicopter models:

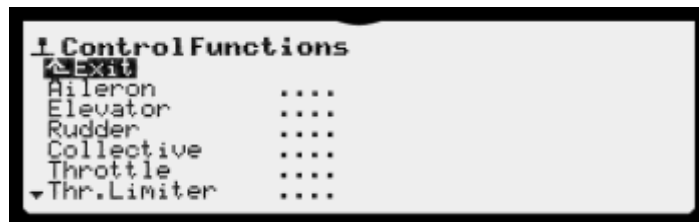

This example shows the screen for the Aileron control function:

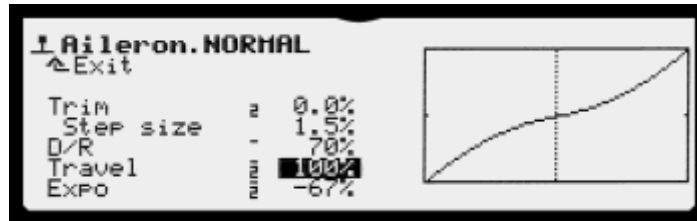

- Line 1: Designation of the control function and the active flight phase
- Line 2: Exit: Return to the parent menu level
- Remaining lines:
 - On the left, all parameters for the selected control function are listed with their set values.
 - Values that can be assigned to a digi-adjuster are marked by a short horizontal dash preceding the value (see section 5.3.1 "Allocating a set value" on page 168).
 - Values that have individual parameters for each flight phase are marked by a small number (the flight phase number) preceding the value (see section 4.3.3 "Flight phases" on page 97).
- Graph
 - The effect of all settings is visualized in the graph on the right side of the screen. The graph illustrates the behaviour of the control function. The dotted vertical line indicates the current position of the control.

4.4.1 Aileron, Elevator, Rudder

The following control functions have identical settings:

- Aileron, Elevator, and Rudder for fixed-wing models
- Aileron, Elevator, and Rudder for helicopter models

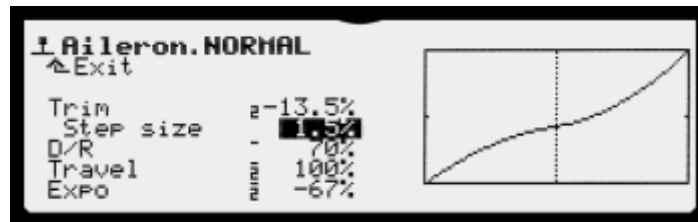

Trim

Current trim setting of the control in the respective flight phase (only display).

Step size

Trim increment: 0.5%, 1.5%, 2.5%, 3.5%

Step size defines the trim change (in %) per trim increment (see section 2.8 "Digital trim" on page 50).



For general-purpose use an increment size of 1.5% has proved a good compromise. For very fast models with accurate control surface linkages or models with very large control surface travels (e.g. FunFlyers) a trim increment size of 1.5% could be too large. In this case, the Step size can be set to 0.5% providing very fine trim control. A large increment size can be useful when you practise flying.

D/R

Dual rate: 10% to 100%

The dual rate setting is used to change the control sensitivity of a control. If the D/R parameter for a control function (e.g. Aileron) is set to 50%, you can use the assigned switch to reduce the control surface travels on the model by half for finer control. The control curve in the graph changes accordingly when you operate the switch assigned to D/R.

Travel

Control travel setting (flight phase specific): 0% to 100%

You can use the Travel parameter to influence the control sensitivity of a control for specific flight phases. That means you can configure a separate value for each flight phase, e.g. in the flight phase NORMAL = 100% for

maximum control surface effectiveness, in the flight phase `SPEED1 = 60%` for finer control.



Make sure to activate the desired flight phase first before making any changes!

`Expo`

Flight phase specific: `-100%` to `+100%`

The `Expo` parameter can be used to assign an exponential characteristic to a control curve.

- For `Expo = 0%`, the control works in a linear fashion.
- The effect of negative `Expo` values is that the control generates smaller control surface travels around the centre position providing finer control.
- The effect of positive `Expo` values is that control surface travels are increased around the centre position.
- The end-travels remain unchanged when `Expo` is used. So, full travel is still available when required.

4.4.2 Throttle (fixed-wing models, vehicles, boats, and funcopters)

The Throttle control function provides the following functions for fixed-wing models:

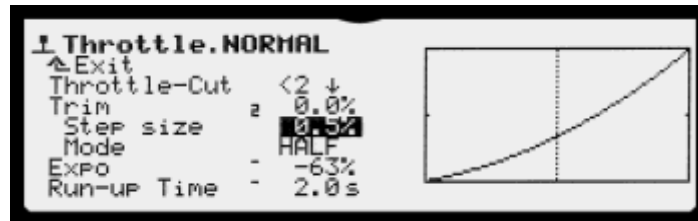

Throttle-Cut

Throttle-cut switch for the motor (only display)

Trim

Current trim setting of the control in the respective flight phase (only display).

Step size

Trim increment: 0.5%, 1.5%, 2.5%, see page 121.

Mode

Used for switching the trim from centre trim to idle trim and adjusting the idle height for models with internal-combustion engines.

CNTR Centre trim. For vehicles with "reverse gear".

HALF Idle trim; the trim is only effective for idle to half throttle.

FULL Idle trim; the trim is effective for idle to full throttle.

Expo

-100% to +100%, see page 122.

Run-up Time

Delay time: 0.0s to 6.0s

As its name implies, the delay time is only effective when the throttle is opened.

4.4.3 Throttle (helicopter)

The Throttle control function provides the following functions for the templates eHELI FBL, eHELIccPM, HELIccPM, and HELImech.:

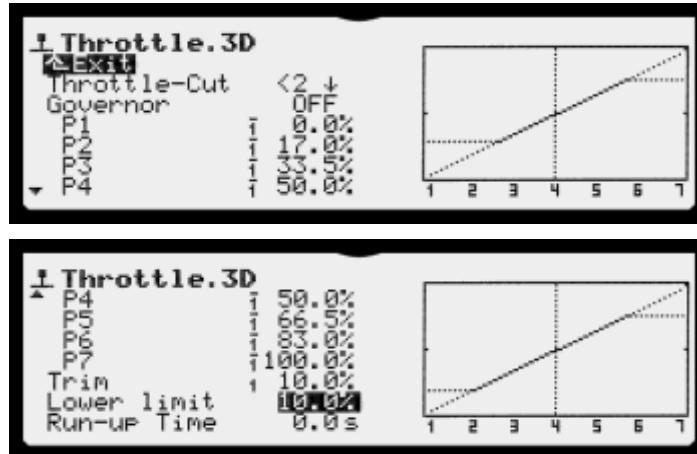

Governor

Choose between throttle curve or controller with active Governor mode (speed controller).

OFF The throttle curve is used. Individual curves are used for each flight phase.

ON A controller with active Governor mode is used: Each flight phase has a fixed value.

Governor OFF

P1 to P7

7-point curve, flight phase specific:

0.0% to 100.0% (= full throttle) for all points on the curve P1 to P7.

Resolution: 0.5%.

Exception: In the auto-rotation flight phase (AUTOROT) all curve points have the same values.

Refer to section 4.4.3.1 "Throttle curves (Governor OFF)" on page 125 for a description of the throttle curves.

Governor ON

Throttle

Fixed value, flight phase specific: 0.0% to 100.0%

Trim

Display of the throttle trim value

Lower limit

Defines the lower limit for the throttle curve to ensure safe idle speed. This setting is overridden in the auto-rotation flight phase (AUTOROT).

Not required for models with electric power system: Thus, set it to 0%. The flight phase-specific throttle trim is added to the lower limit and thus increases the lower limit by the trim value.

The horizontal dotted line in the graph shows the position of the throttle limiter in all flight phases.

Run-up Time

Slow function for throttle: 0.0s to 6.0s

This parameter defines the time for running up from idle to full throttle. This does not affect the run-down time.

4.4.3.1 Throttle curves (Governor OFF)

For each of the flight phases 1 to 4 a separate throttle curve with 7 points can be configured to achieve optimum adaptation of the motor power to the throttle curve setting for the respective flight phase.

The aim is to achieve a constant system speed over the entire collective pitch range. Ultimate fine-tuning of the throttle curve is only possible in flight and depends on many parameters (motor power, motor setting, power characteristics, setting for the collective pitch curve, rotor blades used, etc.). If a parameter is changed, fine-tuning of the throttle curve must usually be repeated.



Tip: Allocate a digi-adjuster to the curve point to be configured. Refer to page 168 in section "Digi-adjuster" for details.

To assist configuration the current position of the collective pitch stick is displayed in the graph as a vertical dotted line.

Special case: auto-rotation

In the AUTOROT flight phase the throttle curve is switched off. All curve points have the same value: You can set the throttle position for auto-rotation at every curve point. The lower limit is switched off. For training with an internal-combustion engine, set a value at which the motor does not yet stop.

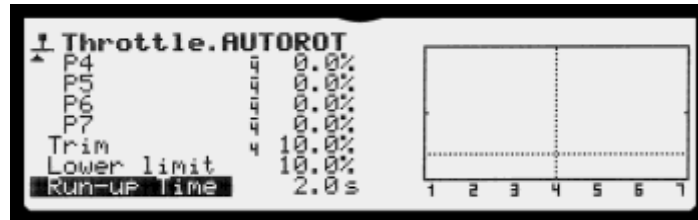

Example: throttle curve in the HOVER flight phase

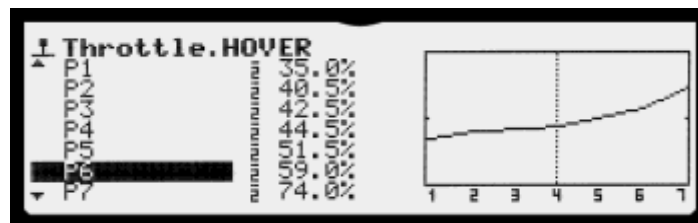

Simple throttle curve for hovering:

- For a negative collective pitch (= descending) the lowest motor power is required (in the example: P1 = 35%).
- A positive collective pitch (= climbing) requires the highest motor power (in the example: P7 = 85.5%).

Example: throttle curve in the 3D flight phase

Symmetrical V-shaped throttle curve for increased throttle when climbing in normal and inverted flight:

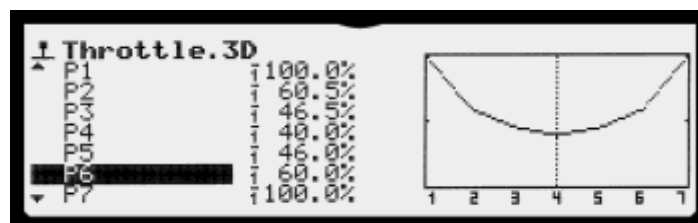

Governor mode

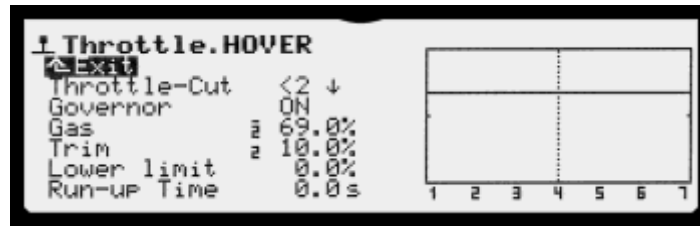

In Governor mode, the speed controller (governor) provides for a constant system speed. It merely requires a fixed value for the required system speed in the respective flight phase. The throttle curve can be switched off in the ControlFunctions > Throttle menu by choosing the setting Governor = ON.

4.4.4 Spoiler, Flap, Retract.Gear, Speed, Aux-1 to Aux-4

The following control functions have identical setting options:

- Spoiler, Flap, Retract.Gear, and Aux-1 to Aux-4 for fixed-wing models
- Spoiler, Speed, Retract.Gear, and Aux-1 to Aux-4 for helicopter models

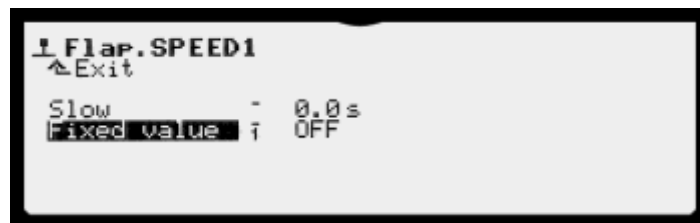

Slow

Slow function: 0.0s to 6.0s

You can use this parameter to reduce the actuation time for the control function; i.e. the connected servos travel from one end to the other during this time.

Fixed value

Flight phase specific: -100%.. 0, OFF, 0.. +100%

Allows setting a control function to fixed positions that are specific to the flight phase. If OFF is selected, the function is controlled by the assigned control, provided an assignment exists. If this is not the case, refer to page 104.

Example of the Flap control function

Objective: Fixed, optimised flap position (camber) in specific flight phases.

You use 3 flight phases: SPEED1, NORMAL, THERMAL1.

Preparation: Use the GLIDER+ model template. A 3-position switch must be assigned to the phases 1-3 for switching between the flight phases (see page 109).

Open the Controls > Flap menu item. To begin with, set estimated values for the Fixed value of the flight phases SPEED1 and THERMAL1. Retain the value OFF for the NORMAL flight phase. Allocate a digi-adjuster (see page 168). The allocation applies to all flight phases.

Now, you can use the digi-adjuster to optimise the camber in flight from the status display. If OFF is selected, the digi-adjuster has no effect: The flaps are controlled by the assigned control. When the optimum camber has been identified allocation of the digi-adjuster can be erased (see page 169).

4.4.5 Gyro

This control function is used to control the sensitivity of a gyro. You can select a different sensitivity setting for each flight phase. Alternatively, you can control the sensitivity using a control (actuator). To this end, simply set the sensitivity to OFF and assign a control to the Gyro control function in the Setup > Assign.Controls menu.



Select the gyro model used in Type of Gyro. If your gyro is heading-hold capable, the gyro type Heading must be selected even if you only use the damping function.

The following table lists the characteristics and differences between the two gyro systems:

Damping gyro	Heading-hold gyro
This gyro type dampens the rotational movement of a model around the axis to which the stabilisation is applied.	This gyro type supports two operating modes ("Mode"): "Damping" and "Heading". You can switch between the

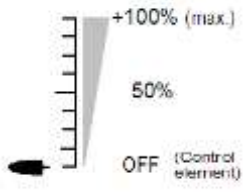
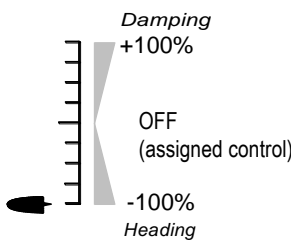
<p>To maintain good control of this axis the damping effect should be reduced proportionally with stick travel. The reduction level is configured by selecting a setting between 0 and 200% for the <code>Suppression</code> parameter.</p> <p>The servo pulse of the gyro channel covers the entire setting range.</p> <p>The sensitivity setting ranges from 0% ... 100%:</p> 	<p>modes by changing the prefix for the sensitivity setting.</p> <p>The gyro operates in Damping mode (as described in the opposite column) if the sensitivity setting is a positive value.</p> <p>In Heading-hold mode the control signal for the axis to be stabilised is used as the setting for the rotational speed around this axis. In neutral position the rotational speed is maintained at zero: The model always points in the same direction.</p> <p>The sensitivity setting ranges from -100% ... +100%:</p> 
--	---

`Fixval.Sense`

With this parameter, a fixed gyro sensitivity is set for each flight phase individually. Alternatively, a control can be used. If this is preferred, set the sensitivity to `OFF` and assign a control to the `Gyro` control function. Refer to page 104 for more details regarding controls assignment.

- The following applies to pure **Damping gyros**: Setting range: 0% to +100%
- The following applies to **Heading gyros**:
 - Setting range for heading-hold: -100% to -1%
 - Setting range for damping: 0% to +100%



Only the value of the activated flight phase can be displayed. When implementing changes make sure to activate the desired flight phase first.

The next line indicates if a heading gyro operates in Damping or Heading mode. If the sensitivity parameter is set to OFF and a control is assigned to the "Gyro" control function, the value supplied by this control and the respective identifier (<E) are displayed next to it on the right. If no control is assigned, nothing is displayed and the sensitivity setting is zero.

Suppression

In Damping mode, the gyro also counteracts intentional control commands. For improved control, the gyro sensitivity can be suppressed proportionally to stick travel using this parameter. This function is already integrated in many gyros. If this is the case, retain the value OFF.

Setting range: OFF to 200%

The setting 200% reduces damping to 0% at half stick travel. If the gyro has its own suppression function, set the value to OFF.

controlled Axis

Here, you select the control function on which the gyro takes effect in the model.

- In Heading-hold mode, the trim for this control function is switched off. For helicopters, the static tail rotor compensation using the TAIL ROTOR mixer is also switched off.
 - In Damping mode, the selected control function is used to reduce the level of damping (suppression).
-



If you are using a Heading-hold gyro, you must check whether the gyro operates in the displayed mode before operating the model. Make sure that the model motor cannot start up. Then, switch on the receive system and the gyro.

- Set the sensitivity to a mid-range negative value: "Heading" is now displayed for mode.
- Hold the rudder or tail rotor stick in an end position.

If the rudder or tail rotor servo moves to an end-point, the gyro operates in Heading-hold mode. If this is not the case, the gyro operates in Damping mode: The rotation direction of the Gyro servo channel must be reversed! The respective procedure is described on page 146.

4.4.6 Collective (only helicopters)

The **Collective** control function is only available for helicopter models that are controlled using collective pitch. The curve for the "Collective" control function is set here.

A separate collective pitch curve with 7 curve points is provided for each flight phase.

Refer to section 7.2.9 "Setting the collective pitch curve" on page 204 for examples of collective pitch curves.

To assist configuration the current position of the collective pitch stick is displayed in the graph as a vertical dotted line.

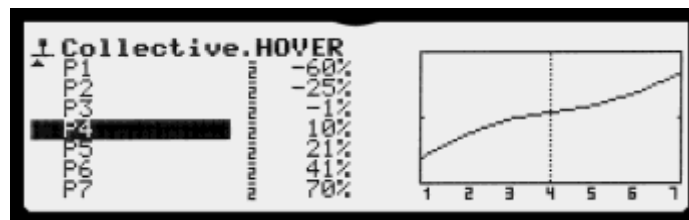

P1 to P7

7-point curve, flight phase specific:

-100% - 0% - +100% for all curve points P1 to P7



Only the collective pitch curve of the activated flight phase can be displayed. When modifying collective pitch curves make sure that the desired flight phase is activated.

4.4.7 Thr.Limiter (only helicopters)

The **Thr.Limiter** control function is only available for helicopter models. To ensure a safe setup of the helicopter, you can use the throttle limiter to restrict the throttle towards full throttle.

Here, you define the time needed for the throttle limiter to run up.

Setting range: 0.0s to 6.0s

4.5 Mixer main menu

You configure the mixers in this menu.

The menu is partially dynamic:

- The menu content differs for fixed-wing models and helicopter models.
- Mixers on the servo side are only listed if they are in use, i.e. they are assigned to a servo.
- Mixers on the control side are always listed, e.g. "Combi-Switch", "Differnt.Ail".

Opening the menu

To open the main menu: Button



4.5.1 Fixed-wing models

Overview

Combi-Switch	Linkage of aileron and rudder, making it easy to fly accurate turns.
Differnt.Ail	Aileron differential for flying accurate turns
ELEVATOR+	Various mixers for the aileron servo. For multiple servos, simply assign the same mixers repeatedly.
V-TAIL+	V-tail with mixers. For models with V-tail, the names of the elevator and rudder servos are changed to V-TAIL+. Then, only rotation directions and travels need to be set.
AILERONS+	Mixers for the ailerons, e.g.: spoiler for raising the ailerons.
<<MIXER-4>>	Freely configurable mixers
<<MIXER-7>>	
Ctrl.Mix1	Mixer for mixing on the control side.
Ctrl.Mix2	

Number, names and functions of the mixers may vary between model templates.

- The mixers **Combi-Switch**, **Differnt.Ail**, and **Ctrl.Mix** are always listed.
- The 7 mixers on the servo side are only listed if they are assigned to a servo.

4.5.1.1 Combi-Switch

The Combi-Switch links aileron and rudder in a way that allows both of the control functions to be controlled by either of the functions. This makes it easier to fly accurate turns.

The Combi-Switch can be configured for specific flight phases. You define the associated switch in the "Setup > Assign.Switches" menu using the CS/DTC parameter (see section 4.3.7 "Assign.Switches" on page 106).

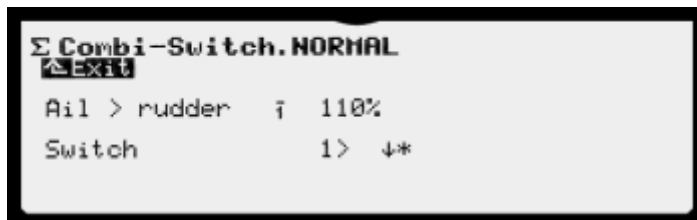

Ail > rudder or Ail < rudder

Percentage of the respective control function (%).

Increment: 2%

Setting range:

-200% OFF +200%

Ail < rudder Default Ail > rudder

Switch

The switch used and its respective switch position are displayed here. The switches are assigned in the Setup > Assign.Switches menu.

4.5.1.2 Differnt.Ail

You use the Differnt.Ail menu to configure the aileron differential. Refer to section 7.1.3.1 "Configuring aileron differential" on page 184 for differential information.

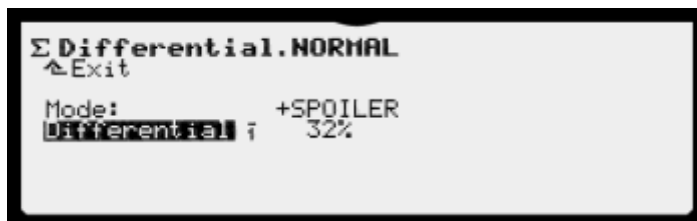

Mode

Possible values:

OFF The differential is switched off.

ON The differential is switched on.

+SPOILER If the ailerons are raised as an additional landing aid, +SPOILER should be selected here.

The differential is then reduced incrementally as the spoiler is extended. The aileron travels in the downward direction are increased. As a result, aileron response is enhanced when the ailerons are raised.

Differnt.Ail

Flight phase specific setting for the differential level.

If the differential is incorrect (aileron travel is reduced in upward direction instead of downward), reverse the value (**REV/CLR** button).

4.5.1.3 Control mixers (Ctrl.Mix)

For fixed-wing models, 2 control mixers are provided. They mix the signal of any second (Source) control function into any (Target) control function. The mixer takes effect on all servos that are connected to the target control function directly or via mixers.



Travel+ / Travel-

Mixing level.

Increment: 1%

Setting range: -100% - OFF - +100%

Source

Control function to be mixed in. The mixer is added without any control settings (Expo, D/R, Travel, Trim).

Target

Control function to be mixed into the Source.

Switch

Switch for switching off the mixer. Without the switch the mixer is switched on.

All three components *Source*, *Target*, and *Switch* can be selected by operating a switch, using the central wheel or pressing the + or - button.

Press the **REV/CLR** button to erase *Source* and *Target*. The *Switch* is inverted when pressing the button the first time and erased when the button is pressed again. Pressing the button a third time restores the original setting.

Origin

Possible values:

- ↕ → ↕ *Source* with centred origin, to *Target* with centred origin.
 Each side can be configured separately using *Travel+* and *Travel-*.
- ↕ → ↓ *Source* with centred origin, to *Target* with origin located at one end of the associated control. The origin was defined during controls assignment.
 Each side can be configured separately using *Travel+* and *Travel-*.
- ↓ → ↕ *Source* with origin located at one end of the associated control. The origin was defined during controls assignment. The *Target* has a centred origin.
 The mixing level is configured using *Travel+*. *Travel-* has no effect.
- ↓ → ↓ *Source* with origin located at one end of the associated control to a *Target* of the same type. The origins were defined during controls assignment.
 The mixing level is configured using *Travel+*. *Travel-* has no effect.

4.5.1.4 Mixers on the servo side

Each of the 7 mixers combines 8 control functions in one common output signal. You should assign a unique name to each mixer. The output signal is assigned to the servos using the name of the mixer. You can assign the same mixer to multiple servos.

For safety reasons, the mixers are defined and configured in separate main menus. The mixers are defined in the Setup > Define mixer menu (see section 4.3.8 "Define mixer" on page 110).

In this menu, the travels and other parameters are configured. Only mixers are shown that are actually used, i.e. that are assigned to a servo.

The following example of the AILERONS+ mixer, which is used in the GLIDER++ model template, illustrates how mixers on the servo side are configured.

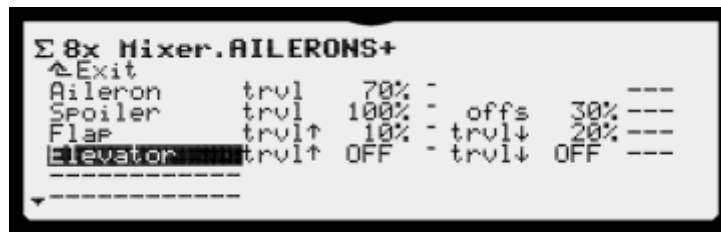

Each line on the screen has 2 input and 2 display fields:

Aileron: The aileron travel in an upward direction is set here. The differential is set using the A.-Differential mixer. Observe the directions of sticks and control surfaces: Reverse the travel using the REV/CLR button, if required. In addition, check the differential direction. Level and direction can be adapted for all aileron inputs using the A.-Differential mixer. If "Spoiler" is mixed in, you should switch the differential mode to +SPOILER.

Spoiler: The end-travel of the spoiler on the aileron is configured in addition to Travel. The direction is determined by the prefix of the set value. Apply an offset (offs) to shift the origin of the output signal to make full use of the servo travel (always in opposite direction of the spoiler).

Flap: Configure the control surface travels separately for up and down using the two set values.

Elevator: The input is used untrimmed. Configure the control surface travels separately for up and down using the two set values. Usually, this mixer should be switchable. As we do not know the type and location of the switches installed in your transmitter it is not possible to assign switches in the templates. However,

you can assign switches in the `Setup > Define mixer` menu (see section 4.3.8 "Define mixer" on page 110).

4.5.2 Helicopter models

Overview

TAIL ROTOR	Tail rotor mixer.
MAINROTOR	Mixer for main rotors up to 4 servos.
<<MIXER-1>>	2 freely configurable mixers with 8 inputs each for mixing on the servo side.
<<MIXER-2>>	
Ctrl.Mix1	4 freely configurable mixers for mixing on the control side.
Ctrl.Mix2	
Ctrl.Mix5	
Ctrl.Mix4	

- The 4 Ctrl.Mix mixers are always shown.
- The other mixers are only displayed if at least one servo is assigned.
- In the model templates HELImech., HELIccpm, and eHeli FBL, the TAIL ROTOR mixer is assigned to a rotor and is, therefore, shown here.
- Servos are assigned to the main rotor mixers in the HELIccpm template; as a result, MAINROTOR is displayed here.
- The MAINROTOR mixer is shown if it is assigned to one of the servos MAINROTOR-R., MAINROTOR-L., MAINROTOR-F, or MAINROTOR-B.

4.5.2.1 TAIL ROTOR

Mixer for the tail rotor. Refer to section 7.2.6 "Checking and adjusting the tail rotor" on page 199 for information on how to check and adjust the tail rotor and for a detailed description of the workflow for the TAIL ROTOR mixer.

Preparations

- To display the TAIL ROTOR mixer in the Mixer menu the TAIL ROTOR must be assigned in the Servo > Assign menu (see section 4.6.2 "Assign" on page 149).
 - A 2-point calibration is sufficient for the TAIL ROTOR servo. Take care that the servo is not stalled (mechanically obstructed) at its end-points (P1, P5)!
-



All settings for throttle and collective pitch must be completed before the TAIL ROTOR mixer is configured. Subsequent changes usually require a correction.

The TAIL ROTOR mixer is only activated in the Dampin9 mode of the gyro. In Heading mode, it is switched off (see section 4.4.5 "Gyro" on page 128). If you do not use Damping mode, you can replace the mixer with the RUDDER control function (Servo > Assign main menu, see section 4.6.2 "Assign" on page 149).

Coll.+ / Coll.-

Separate configuration of the collective pitch mixers for the tail rotor when climbing and descending:

- Coll.+ : correction for climbing
- Coll.- : correction for descending

The exact values can only be established through a programme of flight testing, and vary according to many parameters.

Rudd.Diff.

Reduce tail rotor travel in one direction.

Offset

Set the pitch angle of the tail rotor at 0° collective pitch on the main rotor.

Origin

The origin for the static tail rotor compensation mixer.

Starting from this collective pitch setting angle in the direction of "climbing", the "Collective -> Tail rotor" mixer is added using the value set for Coll.+ . The value set for Coll.- is applied in the opposite direction (descending).

4.5.2.2 MAINROTOR

You control the main rotor of your helicopter model with the MAINROTOR mixer. The **PROFI TX** features a universal swashplate mixer (CCPM) which can be used to control all types of swashplate fitted with 3 to 4 linkage points / servos.

Refer to section 7.2.5 "Checking and adjusting the main rotor" on page 195 for information on how to check and adjust the main rotor and for a detailed description of the workflow for the MAINROTOR mixer.



To ensure that the swashplate moves in the required manner, the swashplate servos must be connected to the receiver in the correct sequence. The channel assignment varies according to the selected servo assignment and can be viewed at any time in the Servo > Assign menu (see section 4.6.2 "Assign" on page 149):

Servo	Description
MAINROTOR-FB	Front or back swashplate servo
MAINROTOR-L.	Left swashplate servo (as seen from the tail)
MAINROTOR-R.	Right swashplate servo (as seen from the tail)
MAINROTOR-4	Fourth swashplate servo, only useful when installed at 90°

Geometry

Angle between the MAINROTOR-FB swashplate servo and the lateral MAINROTOR-L. / MAINROTOR-R. servos.

Setting range: 90 to 150° / -90 to -150°

Default: 120°



The angle must be entered with a negative prefix "-" if the MAINROTOR-FB servo is at the front when seen from the tail (see example 2).

Example 1: 3-point 120° swashplate

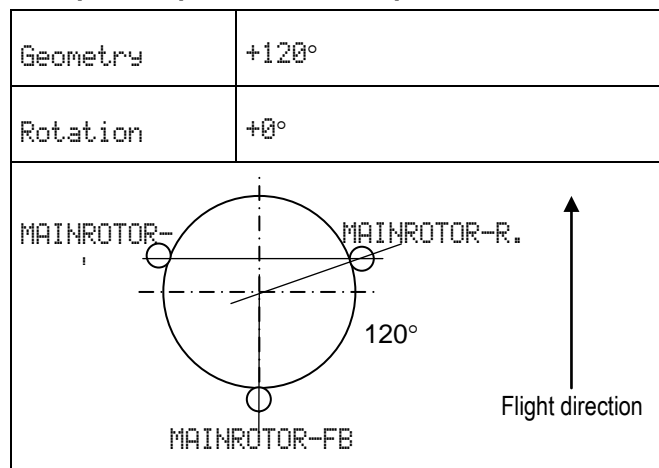

Example 2: 4-point 90° swashplate

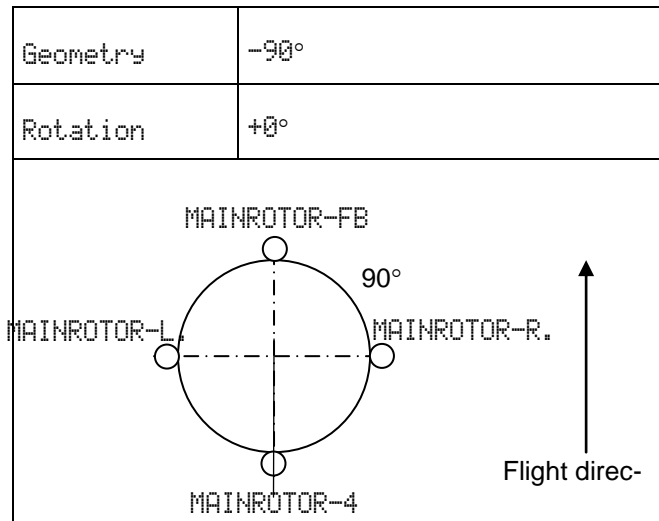

Rotation

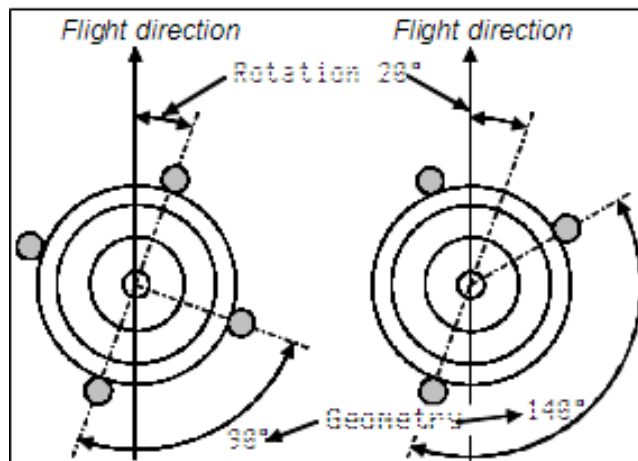

Virtual swashplate rotation. It is required in the following cases:

- The swashplate is physically installed in the model in such a way that the MAINROTOR-FB servo is not located on the centreline.
- The model rolls (aileron movement) when an elevator control command is given, and vice versa.



- For virtual rotation in the clockwise direction: set negative values
- For virtual rotation in the anti-clockwise direction: set positive values

Lever

Is only required for 3-point swashplates whose linkage points are not equidistant from the rotor shaft centre for mechanical reasons.

The difference is set as a percentage (%) of the radial distance (from rotor shaft centre to the linkage point) between the MAINROTOR-FB servo and the lateral MAINROTOR-L. / MAINROTOR-R. servos. The lateral levers are set to 100%.

Setting range: -100% - 0° - 100%

Default: 0%

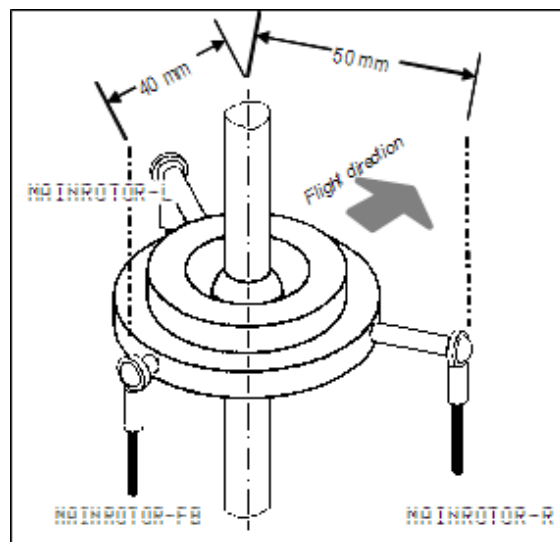

Example

Distance for MAINROTOR-FB: 40 mm

Distance for MAINROTOR-R. / MAINROTOR-L. : 50 mm (= 100%)

The lever for the fore-and-aft linkage (MAINROTOR-FB) is 20% shorter than the levers for the two side-mounted linkages.

So, you apply the following setting: Lever +/- -20%.

**TIP**

Once you have entered the mechanical values of the swashplate as parameters for the MAINROTOR mixer, the next step is to carry out a careful and thorough calibration of the main rotor servos in the `Servo > Calibrate` menu (see section 4.6.1 "Calibrate" on page 146).

This step is essential to ensure accurate swashplate control. The direction of servo rotation can be checked using collective pitch control commands. If servos rotate in the wrong direction, you will need to reverse the rotation direction (**REV/CLR** button). It can be useful to disconnect the pushrods between the swashplate and the main rotor for the servo calibration process, as this makes it easier to calibrate the maximum travels (P1, P5).

The control travels for Aileron, Elevator, and Collective are then configured in the `ControlFunctions` menu (see section 4.4 "ControlFunctions main menu" on page 118).

**TIP: Helicopters with Heim mechanical system**

If you wish to fly a helicopter fitted with the HEIM mechanical system, proceed as follows:

1. Select the HELIccpM template for the new model.
2. Change the MAINROTOR-FB assignment to Elevator in the `Servo > Assign` menu. Then the front/back swashplate servo is controlled directly by the Elevator.

Set Geometry to 90° in the MAINROTOR mixer. This means that the MAINROTOR-L. or MAINROTOR-R. servos are only controlled by the Aileron and Collective functions.

4.5.2.3 Control mixers (Ctrl.Mix)

These "mixers on the control side" mix the signal of any second (Source) control function into any (Target) control function. Mixing takes effect on all servos that are connected to the target control function either directly or via mixer. These mixers are typically used for throttle compensation in helicopters. In the helicopter templates, 4 of these mixers are provided.

Refer to page 134 for a detailed description of the Ctrl.Mix mixers.

4.5.2.4 Mixers on the servo side

"Mixers on the servo side" are mixers that combine up to 8 control functions in one common signal. Their output signal can be assigned to one or more servos. The mixers are defined in the Setup > Define mixer menu (see section 4.3.8 "Define mixer" on page 110).

If they are assigned to a servo, these mixers can be configured in the Mixer menu according to the requirements of the particular model.

Refer to page 136 for instructions on how to configure mixers on the servo side.

4.6 Servo main menu

You can use this menu to configure, manage and monitor servos.

Overview

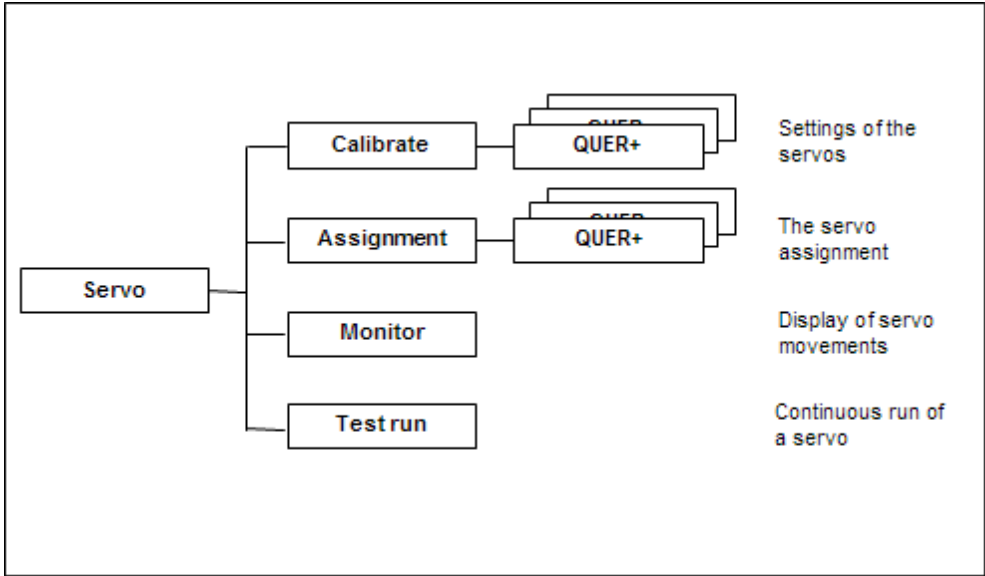

Opening the menu

To open the main menu: Button



4.6.1 Calibrate

You can use the `Calibrate` menu to calibrate the travels, centre and any intermediate points for all servos so that they move evenly and run only to the permissible end-points.

Surface pairs such as ailerons and camber-changing flaps can be trimmed for synchronised movement in this menu. The 5-point curve requires more configuration work, but yields better results.



The menu shows a list of all the servos which can be used with your transmitter type (9, 12, or 16 servos).

The sub-menu is identical for all servos.

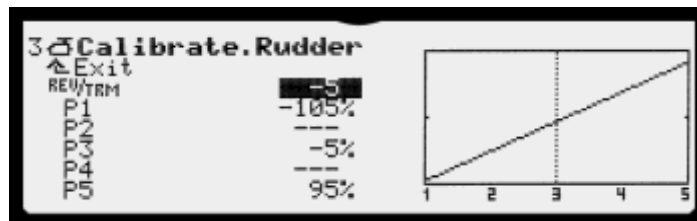

Parameter changes are immediately reflected in the graph. The channel number (receiver output) of the selected servo is shown above the graph.

REV/TRM

The `REV/TRM` parameter has two functions:

- Servo reverse (`REV`) changes the direction of servo rotation. To reverse the direction of servo rotation "open" the set point and press the `REV/CLR` button: The entire curve is "reversed" and the prefixes of all curve points change.
- Servo trim (`TRM`) shifts all points on the servo curve in parallel. Use the wheel or the `+/-` buttons to adjust the trim.

The set trim value results in a parallel shift of the curve. The curve points are limited to $\pm 110\%$. The shape of the curve remains unchanged until the limit is reached. The effect is the same as the standard trim procedure.

P1 to P5

The number of configurable servo calibration points (min. 2, max. 5 points) varies according to the setting selected when initially assigning the servos (see section 4.6.2 "Assign" on page 149).

You can complete several tasks by making adjustments to the servo calibration points (parameters P1 ... P5):

- Establish the maximum working range of the servo:
The servo travels set at this point are never exceeded by the transmitter (protection from mechanical servo stalling, limit).
- Compensate for mechanical differences in the control surface linkage:
For example, adjust the flaps in a multi-flap wing so that they match.

NOTICE

Servo calibration should only be used for fine-tuning. Careful and thorough mechanical pre-adjustment is strongly recommended.

Never reduce the maximum servo travels (P1 and P5) by more than approx. 30%. Otherwise, available servo power is wasted, you will forfeit servo resolution and the play in the servo gearbox will be amplified unnecessarily.

Procedure

1. Adjust the direction of servo rotation.
 - Servos controlled by basic functions (e.g. Aileron, Elevator, Rudder, ...):
First, check that the rotation direction of the controlled surface correlates to the control movement. If required, change the rotation direction in the REV/TRM parameter (**REV/CLR** button).
If the rotation direction is changed later, a re-calibration is required.
 - Servos controlled by mixers (e.g. AILERONS+, DELTA+, V-TAIL+, ...):
In the case of servos to which a mixer has been assigned, the absolute direction of servo rotation is initially irrelevant. The correct direction can be set later in the mixer. However, for paired control surfaces—e.g. ailerons with mixers—the ailerons must rotate in opposite directions. If this is not the case, one of the servos must be reversed.
2. Select a calibration point (P1 to P5) and open the input field.
3. Press the allocation button  for the digi-adjusters.
The servo—and all the other servos to which the same control function or mixer is assigned—automatically assume the position corresponding to the

percentage figure at the selected calibration point.

With one hand you can easily and conveniently measure and check the control surface travel (ruler, calliper), while the other hand remains free to change the value using the wheel.

4. If the travel is correct, press the allocation button **F**.

The servo(s) assume(s) the position corresponding to the position of the associated control.



Vertical line for orientation:

The vertical dotted line in the graph shows the current position of the associated control for easier orientation. If you activate a value using the allocation button **F**, the vertical line jumps to the corresponding point and remains there until you press the allocation button again or operate the associated control.

4.6.2 Assign

Here, you assign a control function or a mixer to your servos.

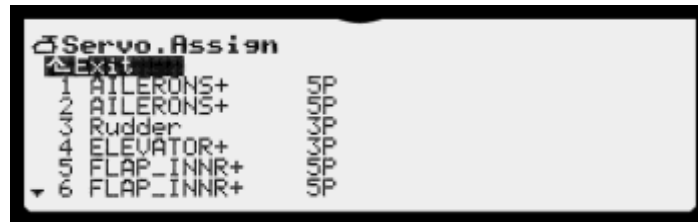

The menu shows a list of all the servos.

The following information is displayed for each servo:

Servo number

Number of the servo; corresponds to the number of the servo connector on the receiver.

Control function / mixer

Here, you select the control function or mixer whose signal is to be fed to this receiver output. Multiple output of control functions and mixers is possible, e.g. if the elevator is linked to several servos.

"-----" has the following meaning: The receiver output is not used. A neutral pulse is fed to the receiver.

nP

Number of servo calibration points available for selection in the **Calibrate** menu (see page 146).

2P 2 points (e.g. for Throttle, Towing dog, Retract.Gear)

3P 3 points (e.g. Elevator, Rudder)

5P 5 points (trim several servos / control surfaces for synchronised movement)

Assignment procedure

1. Select the servo.
2. Press the wheel or the **ENTER** button.
3. Select the function (control function or mixer).
4. Press the wheel or the **ENTER** button.
5. Select the number of calibration points.

6. Press the wheel or the **ENTER** button.
 - The input cursor returns to the servo number.
 - This completes the assignment procedure for one receiver output.

Procedure for erasing an assignment

1. Select the servo.
2. Press the wheel or the **ENTER** button.
3. Press the **REV/CLR** button. Pressing the button again restores the assignment.
4. Press the wheel or the **ENTER** button.

4.6.3 Monitor

The servo monitor visualises the actuation movement of the servos. It enables you to detect errors and check the function / operation of cruise controls, gyro systems, speed controllers, etc.

Two display types are available:

- graphic, with a display of output signals in bar-chart form
- numerical, with the values stated as percentages

Press the **+ / -** buttons or use the central wheel to toggle between the two screen types. The figure shows the servo monitor for the **PROFI TX 16**. The display varies according to the number of available servo channels.

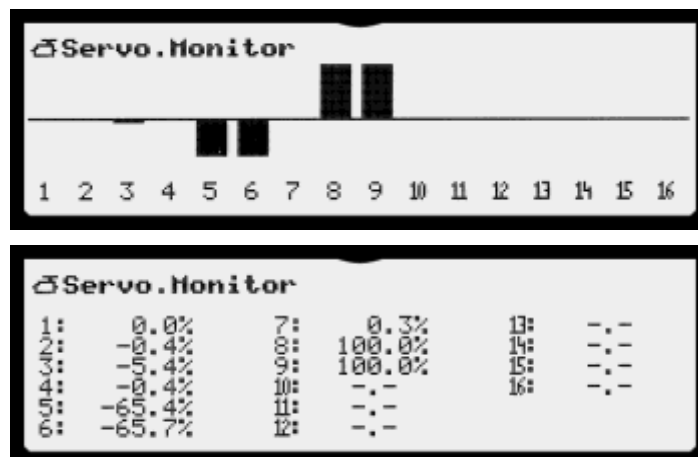

4.6.4 Test run

This function triggers an automatic servo run that can be used for testing or demonstration purposes or as an aid in range checks.

While the test run is activated the selected control function cannot be controlled manually!

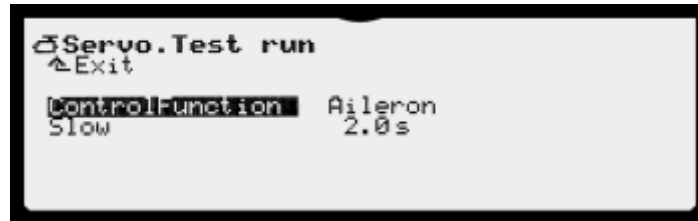

ControlFunction

Here, you select the control function intended for continuous operation. The test run is switched off when the name of the function is crossed out. Press the + / - buttons or use the central wheel to select the control function. When the selection is changed, the test run is switched off so that critical functions such as motor or landing gear are not operated when scrolling.

Slow

Time required by the control function to move from one end position to the other.

Range: 0.1 to 6.0 seconds

OFF: Switched off, no movement

Starting a test run

Set the run time. Select the desired control function and then press the **REV/CLR** button. An even control movement is generated—moving from one end position of the control to the other. All the servos that are either directly controlled by this function or indirectly using mixers start to run.

Stopping the test run

To stop the test run do one of the following:

- Open the `ControlFunction` selection and press the **REV/CLR** button: The control function is shown crossed out.
- Open the `ControlFunction` selection and select a different control function: The control function is shown crossed out.
- Open `Slow` and set it to `OFF`.

4.7 Timer main menu

You can use this menu to set the current time and manage the PROFI TX timers.

Overview

Model	Model uptime count
Timer 1	Three freely configurable timers.
Timer 2	Operating modes: frame, sum, interval.
Timer 3	Options: Up, Count down, Save value, Announce.
Alarm Clock	Configuring the integrated alarm clock function
Date & Time	Setting date and time

Opening the menu

To open the main menu: Button 



4.7.1 Model uptime count

The Model timer is available for each model memory. It records the operating time (uptime count) for each model. The timer only runs when the transmitter emits RF signals.



Time

Displays the summed up operating time (uptime count) for the model in hours and minutes.

Range: 1000 h 00 m

Resetting the timer to 0h00

1. Select the input field **Time**.
2. Press the wheel or the **ENTER** button to open the input field.
3. Press the **REV/CLR** button.
4. Press the wheel or the **ENTER** button to close the input field.

4.7.2 Timer 1 to timer 3

The three timers are suitable for universal use and share the same structure. Each timer can be configured freely. You can select operating mode, counting mode (Up or Count down), etc. as required.

Each timer has time markers at 5-4-3-2-1 minute(s) and 30-20-15-10-5-0 seconds.



Mode

Select the operating mode for the timer: frame, sum, or interval

1. **Frame:** A time window is monitored. Frame times are set in competitions, for example, where a certain flying task must be completed within a specified time.
 - a. The timer starts when the assigned switch is set to the ON position.
 - b. It can only be stopped when either the alarm time (frame time) is reached or the frame is opened using the freely assignable "Frame OPEN" switch.
2. **Sum:** The timer measures the time during which the assigned switch is set to ON.
3. **Interval:** This operating mode is used to monitor a specified time repeatedly or only once.

Time

This field indicates the time that has elapsed since timer start. After selecting this field you can reset the timer to zero by pressing the **REV/CLR** button.

Alarm

Time at which an alarm is to be issued. When Count down is selected, the timer starts at this time, counts down to zero; when zero is reached, the timer counts up again. The alarm is issued when zero is reached.

Maximum setting range: 4:00:00

Switch

Displays the switch used to control the timer and the respective switched state. If the switch is set to ON, i.e. the timer is running, an asterisk "*" is shown next to the arrow. Refer to page 109 for information on how to assign the switch.

Count down

When Count down is activated, the timer starts at the specified alarm time, counts down to zero and then up again. The alarm is issued when zero is reached.

Otherwise, the timer starts at zero and counts up.

Save value

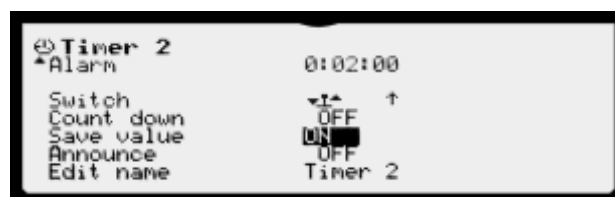

Here, you select if the counter reading is stored when the memory is changed or the device is switched off.

- Select ON to store the counter reading.
- Select OFF if you wish the timer to restart.

Announce

Here, you select if time markers are announced.

Time markers are defined at 5, 3, 2, 1 minute(s) and 30, 20, 15, 10, 5, 0 seconds.

Edit name

Specify a name for the timer. Refer to section 5.1.3 "Text input" on page 166 for details.

4.7.3 Set Alarm Clock

The clock in the **PROFI TX** (see section 4.7.4 "Date & Time" on page 156) has an alarm clock function.

When the set alarm clock time is reached, the alarm clock rings in brief intervals for 10 minutes and the time is announced. During this time, a clock icon, the date, time, and battery charge level are displayed on the screen.

To stop the alarm press the wheel.

In line 1, the current date and time are displayed on the right.

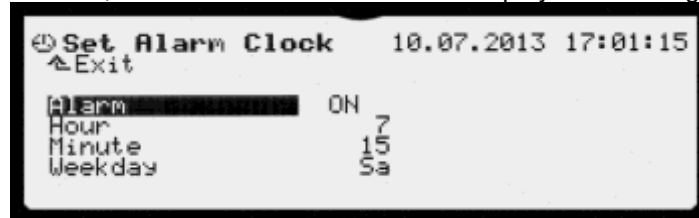

OFF

Here, you activate the alarm clock. You must reactivate the alarm clock for each alarming procedure.

Hour

Hours of the alarm clock time in 24-hour format.

Minute:

Minutes of the alarm clock time.

Weekday

Day of the week on which the alarm clock should ring.

OFF: The weekday is ignored.

4.7.4 Date & Time

The **PROFI TX** features a clock with calendar that continues to run when the device is switched off. The clock (RTC) is used for the alarm clock function and for the file system on the SD card. **The clock must be reset after removing the battery.**

In line 1, date and time are displayed on the right.

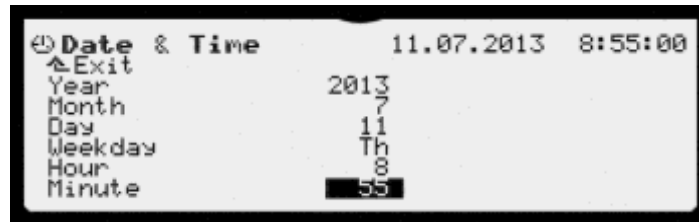

- Move the input cursor in turn to the menu items "Year", "Month", "Day", "Weekday", "Hour", and "Minute".
- Open the input field next to the menu item by pressing the wheel or the **ENTER** button.
- Set the date or time using the wheel or the + / - buttons.
- Finish entering by pressing the wheel or the **ENTER** button.

Year

Set the current year.

Month

Set the current month.

Weekday

Set the current weekday.

Hour

Set the hour of the current time in 24-hour format.

Minute:

Set the current minute.



The seconds display remains zero with the **Minute** input field open, i.e. the clock is stopped while the input field is open.

For an accurate time setting, set the next minute to come and close the input field when the clock strikes the full minute.

4.8 Memory main menu

You can use this menu to manage the model memories in your **PROFI TX**.

Overview

Select	Here, you switch between model memories.
Copy	Copy the model memory.
New model	Create a new model memory.
Edit name	Edit the name of the current model memory.
Erase	Erase a model memory. The current memory cannot be erased.
Safety check	Activate a safety function. After starting the device or switching to a different memory, no RF signals are emitted. Thus, you have the time to check the position of all the safety-related controls such as "Throttle", "Retract.Gear", "Flight phase", etc.

Opening the menu

To open the main menu: Button 



4.8.1 Select

You can switch to a different model memory in this menu. The menu shows a list of all the available model memories. The name of the current model memory is bolded.



Move the input cursor to the desired model memory. The change takes effect when you press the wheel or the **ENTER** button.

The model memory currently in use is stored to the internal SD card and the newly selected model memory is loaded from the card.

Then, the screen switches to status display #2.



If the safety check is switched on (Safety check menu, see page 162), the safety check prompt is displayed on the screen when you change the model memory.

Press any transmitter button to exit the safety check.

4.8.2 Copy

You can copy the model memory to a different memory cell in this menu.



The menu shows a list of all the available model memories. The current memory is bolded.

1. Select a model memory.
2. Confirm your selection by pressing the wheel or the **ENTER** button.

The name of the memory you have selected for copying is shown inverted and in parentheses.

3. Move the memory to the target memory cell using the central wheel.
4. Copying is initiated by pressing the wheel or the ENTER button. Now, either of the following cases is possible:
 - a. The target memory is empty: The model data is copied to the target memory. The model name is applied.
 - b. The target memory is in use: You are prompted to confirm that you wish to overwrite the memory.



Pressing **REV/CLR**:

Overwrites the existing memory with the copy.

Pressing **ENTER** or wheel:

Cancels copying; the target memory remains unchanged.

5. Now, you can copy further memories or close the menu using **Exit**.

4.8.3 New model

You can use the **New model** menu to create new model memories.

All the settings in this menu are retained, so, you do not have to re-enter the full set of information for every new model memory.

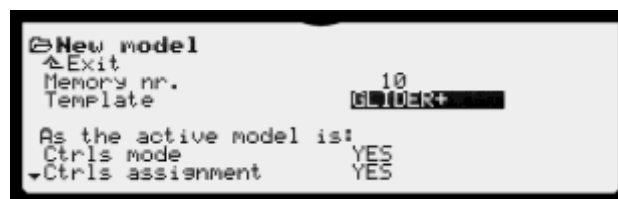

Memory nr.

Data is automatically saved to the next empty memory cell in the transmitter.

It is not possible to choose at will. You can copy the model to a different memory cell later (see section 4.8.2 "Copy" on page 158).

If all the memories are in use, the following information is displayed on screen:

Memory nr.-1

If you still try to create the new model by pressing OK, the following warning is displayed:

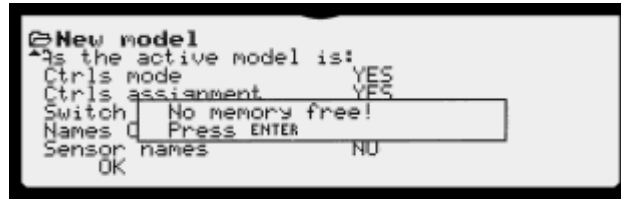

You cannot create new models until you have erased a model memory (see section 4.8.5 "Erase" on page 162).

Template

Template for the new model. The template provides the basic configuration for certain model types—fixed-wing models, vehicles, helicopters. The model type cannot be changed later.

The scrollable field shows a list of all the model templates available in the **PROFI TX** (see section 3 "Model templates" on page 55).

As the active model

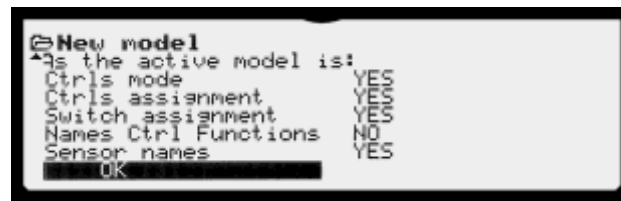

Here, you specify the setting areas to be inherited from the current model.

If the current model and the template are incompatible, not all of the areas are inherited. All fixed-wing models are compatible with each other; the same applies to all helicopters. Vehicles, boats, and crawler-type vehicles (tanks) are not compatible with any other template.

Ctrl's Mode

YES	NO
The stick assignment is inherited from the current model.	Mode 0 is used. This setting can be changed later.

Ctrl's assignment

YES	NO
Only if compatible: The controls assignment is inherited from the current model.	Controls assignment as defined in the template.

Switch assignment

YES	NO
Only the assignment list defined in the Setup > Assign.Switches menu is inherited.	Switch assignment as defined in the template.

Names Ctrl Functions

YES	NO
Only if compatible: The names of the control functions are inherited from the current model.	Designations as defined by the template.

Sensor names

YES	NO
The names of the sensors are inherited from the current model.	Names as defined by the template.

OK

When you have selected all options mentioned above move the input cursor to OK. You create a new model memory with the settings selected above by pressing the wheel or the **ENTER** button.

The device automatically switches to the new model memory and you can immediately start to configure further settings.

If you decide that you do not wish to create a model template, close the input screen using **↵Exit**.

4.8.4 Edit name

You can use the `Edit name` menu to change the name of the currently selected model. The name can have up to 18 characters.

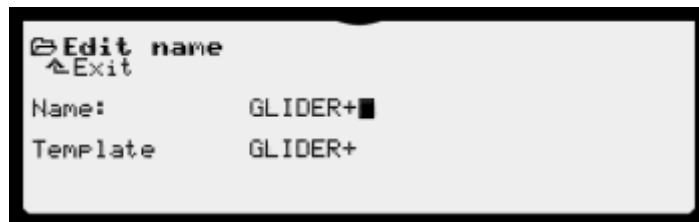

The current name and the designation of the associated model template are displayed on screen. Refer to section 5.1.3 "Text input" on page 166 for details.

4.8.5 Erase

Here, one or more model memories can be erased.



The menu shows a list of all the available model memories. The current model memory is bolded and cannot be erased.

1. Select a model memory.
2. Press the wheel or the **ENTER** button.
3. A safety check prompt is displayed:

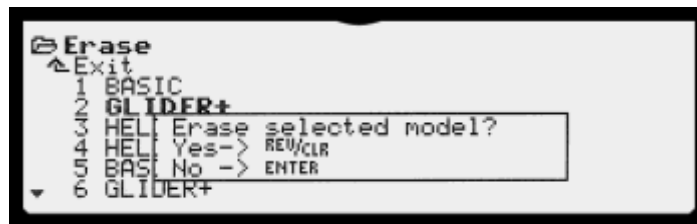

Pressing **REV/CLR**: Erases the selected memory.

Pressing **ENTER** or wheel: Erasing is cancelled.

4. You can erase further memories or close the menu using **Exit**.

4.8.6 Safety check

Safety check switches the safety check prompt on or off. This function is activated by default for newly created model memories.

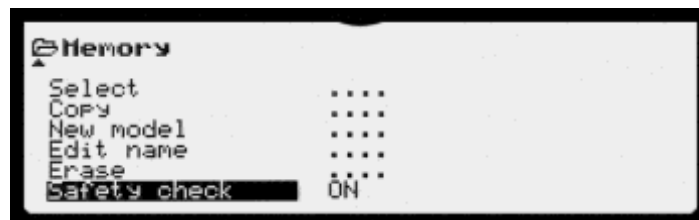

The safety check allows you to check the position of all the controls before establishing a wireless connection. Pay special attention to the control for throttle and landing gear. Refer to page 44 for more details.

4.9 Error messages

The **PROFI TX** checks the condition of the current memory when it is switched on or the model memory is switched. If it detects a problem, the following error message appears:

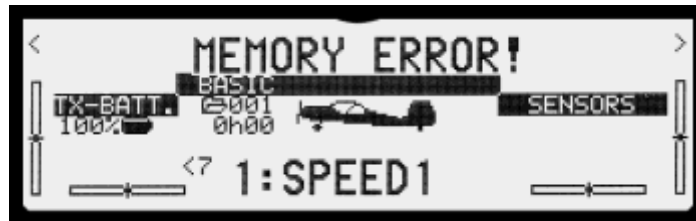

If this error message is displayed, proceed as follows:

- Copy the memory to a different memory number.
- Change the name to "defective". For safety reasons, this memory must not be used again.
- Switch to the copy.
- Carefully check all the settings of the model memory.

Contact a Service Centre if the error occurs repeatedly.

5 Operating the transmitter

The **PROFI TX** is operated using the keypad and the central wheel.

5.1 Operation using the keypad



Figure 17: Keypad

5.1.1 Menu buttons



The keypad is arranged in two rows. The upper row provides quick and direct access to the 6 main menus.

- Pressing one of the buttons in a status display or a different menu opens the menu associated with the button.
- If you press one of the buttons when the associated menu is displayed, the screen display switches to the parent menu level until the current status display is shown again.

Button	Menu
	Setup
	ControlFunctions
	Define mixer
	Servo
	Timer
	Memory

5.1.2 Buttons for special functions

The lower keypad row provides the following functions:

Button	Function
	<ul style="list-style-type: none"> • Allocation button: Activation button for the digi-adjusters (see section 5.3 "Digi-adjuster" on page 168). • In the menu: <code>Servo > Calibrate</code>: The servo—and all the other servos to which the same control function or mixer is assigned—automatically assume the position corresponding to the percentage figure at the selected calibration point (see section 4.6.1 "Calibrate" on page 146).
	<p>Erases and/or reverses (inverts) set values. Confirmation when erasing model memories or text.</p> <p>In case of bipolar set values, pressing the button three times restores the original value: Invert—Erase—Restore.</p>
<p>ENTER</p>	<p>Open / close input fields or trigger a function; pressing the button has the same effect as pressing the wheel.</p>
	<p>Down (minus) button; pressing the button has the same effect as turning the wheel in the anti-clockwise direction:</p> <ul style="list-style-type: none"> • In the status displays: Every time you press the button the screen cycles back to the previous status display. • In the menus: Every time you press the button the cursor is moved to the previous menu item. • In a scrollable field: Every time you press the button the value or the content of the scrollable field is reduced.

	<p>Up (plus) button; pressing the button has the same effect as turning the wheel in the clockwise direction:</p> <ul style="list-style-type: none"> • In the status displays: Every time you press the button the screen cycles to the next status display. • In the menus: Every time you press the button the cursor is moved to the next menu item. • In a scrollable field: Every time you press the button the value or the content of the scrollable field is increased.
---	--

5.1.3 Text input

Use the buttons that are labelled with characters for text input:

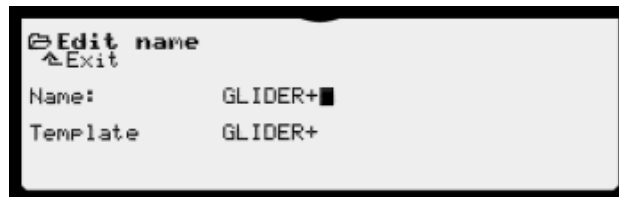

1. Open the input field by pressing the **ENTER** button or the wheel. The first character is now highlighted to indicate the input position.
2. Change the input position as needed using the wheel.
3. Enter the text at the input position.

The procedure for text input is identical to a simple mobile phone:

- A list of 3 to 4 alphabetic characters (upper and lower case plus special characters) and one numeric character is assigned to each button.
- The desired character is selected by repeatedly pressing the button.
- The cursor moves to the next input position when you wait for 1.5 seconds or you use a different button.

4. Finish entering by pressing the **ENTER** button or the wheel.
5. If there are characters below or to the right of the input cursor, you are prompted to confirm that these characters, i.e. the rest of the text, should be deleted.

Press the **REV/CLR** button for "Yes".

Press the **ENTER** button for "No".

The prompt is not displayed if the input cursor is positioned on the first character.

5.2 Operation using the wheel

You can use the central wheel to navigate through the menus and to edit set values. The wheel can be turned in increments to the left or to the right and it can be pressed.

Turning the wheel

- In the status displays:
Every increment in the clockwise / anti-clockwise direction cycles to the next status display or back to the previous status display.
- In the menus:
Every increment in the clockwise / anti-clockwise direction moves the cursor to the next / previous menu item.
- In a scrollable field:
Every increment in the clockwise / anti-clockwise direction increases / reduces the value or the content of the scrollable field.

Pressing the wheel

Press the wheel to open / close an input field or to trigger a function. Pressing the wheel has the same effect as pressing the **ENTER** button (see section 5.1.2 "Buttons for special functions" on page 165).

5.3 Digi-adjuster

A digi-adjuster can be installed in each of the two installation slots on the right and left side at the transmitter front (see section 2.3.4 "Installing additional controls" on page 36).

A digi-adjuster can be allocated to most of the set values. This allows direct and quick optimisation of set values.

Digi-adjusters only function on the status display level.

5.3.1 Allocating a set value

Values that can be allocated to a digi-adjuster are marked by a horizontal dash

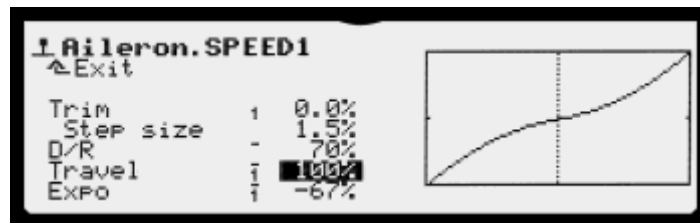

preceding the input field.

1. Open the desired input field.
2. Press the allocation button

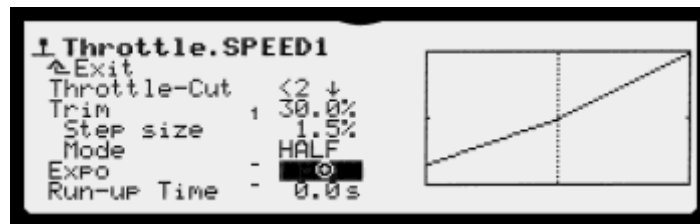

The allocation icon is displayed in the input field:

The following icon appears for values that cannot be allocated:

3. Turn the desired digi-adjuster.

The icon disappears.



If you change your mind and decide not to allocate a digi-adjuster, simply close the input field. The allocation icon disappears and the value is displayed again.

5.3.2 Setting a value

Initially, the digi-adjusters are disabled after switching the device on. The padlock icon in the middle of the first line is closed.

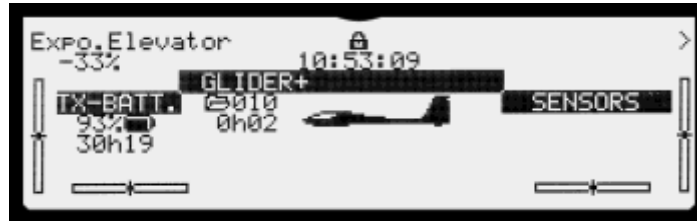

1. Press the allocation button F to open the input.

In the status displays #2 to #8, the button activates / deactivates the optional digi-adjusters.

- The padlock icon changes from closed to open.
- If a value is allocated, the set value is displayed in the first line in the top left corner.

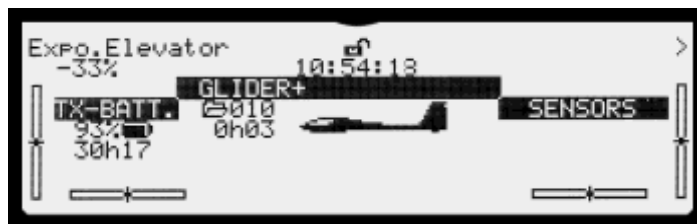

Turn one of the digi-adjusters: The set value is temporarily displayed in double font size for easier reading.

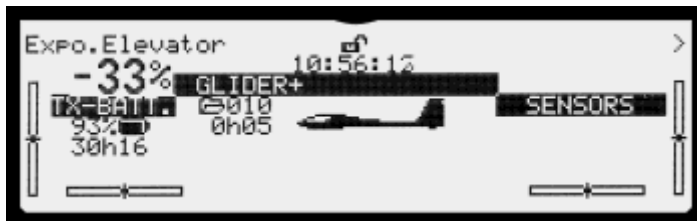

5.3.3 Erasing the allocation

Press the allocation button  to open the padlock icon.

Press and hold the **REV/CLR** button and turn the digi-adjuster for which you wish to erase the allocation.



Allocations can only be erased in status display #2 (see page 88).

5.4 Assigning controls to control functions

The assignment for controls and switches defines which functions in the transmitter or model are controlled by which control.

Controls, i.e. actuators, are:

- Sticks
- Slide potentiometers
- Rotary potentiometers
- Switches and their designated buttons

Controls can be assigned to control functions and/or switched functions. Multiple assignments are possible and in many cases quite useful, e.g. a stick can be assigned to the "Throttle" control function and also be used as a switch for one or more timers.

Examples of control functions: "Aileron", "Throttle", "Retract.Gear", "Spoiler", "Flap".

Examples of switched functions: Timer ON/OFF, dual rate, throttle-cut.

5.4.1 Assign.Controls

Controls are assigned in the `Setup > Setup > Assign.Controls` menu. The menu shows a list of all the controls provided in the software (see section 4.3.6 "Assign.Controls" on page 104).

The basic functions ("Aileron" / "Elevator" / "Rudder" for fixed-wing models and helicopters plus "Collective" for helicopters only) are always assigned to the sticks. They are not assigned using the list, but by configuring the controls mode (see page 172). One vertical axis always remains unassigned and can be assigned using the list ( icon). This is typically used for "Throttle" or "Spoiler" in glider-type models.



You can use this menu to customise the controls assignment according to your needs.

Controls mode

Ailerons, elevators and rudders are controlled by the stick units. The stick units are assigned to the individual axes using a standardised controls mode (1 to 4).

You configure the controls mode in the `Setup > Assign.Controls > Ctrl Mode` menu (see section 4.3.6 "Assign.Controls" on page 104). One vertical axis always remains unassigned (⏏ icon) and can be assigned using the assignment list. In power models, ⏏ is typically used for "Throttle", in glider-type models for "Spoiler".

The controls modes:

Mode	left vertical	left horizontal	left vertical	right horizontal
1	Elevator	Rudder	⏏	Aileron
2	⏏	Rudder	Elevator	Aileron
3	Elevator	Aileron	⏏	Rudder
4	⏏	Aileron	Elevator	Rudder

Assignment list

The assignments are stored in the memory of the respective model.

To assign a control function proceed as follows:

1. Move the input cursor to the control function you wish to assign a control to.
2. Open the input field.
3. Assign a control by pressing the + / - buttons, by using the central wheel or by operating the control.
4. To set the actuation direction keep the control in the desired zero position and close the input field. Alternatively, you can invert, erase or reset the control by pressing the **REV/CLR** button, if required.

You can freely assign 21 physical and 6 logical controls to the following

12 control functions:

Icon	Control
⏏	Free stick that is not assigned to "Aileron", "Rudder" or "Elevator".

E, F	E = left slider, F = right slider
G, H	G = slider on the far left, H = slider on the far right
<1,<2,<3,<4,<5,<6,<7	Installation slots on the front left side for switches, buttons, and rotary potentiometers
1>,2>,3>,4>,5>,6>,7>	Installation slots on the front right side for switches, buttons, and rotary potentiometers
< I	Left stick button or stick switch
I >	Right stick button or stick switch
MS1, MS2	MagicSwitches (logical controls)
Fp1, Fp2, Fp3, Fp4	Flight phases (logical controls)

Control functions of the model templates

The following control functions are defined in the **PROFI TX** model templates. The control functions 1 to 3 are assigned using the controls mode.

	Fixed-wing models	Vehicles	Ships / boats	Tanks	Helicopters
1	<i>Aileron</i>	<i>Gimbal h</i>	<i>Gimbal h</i>	<i>Turret turn</i>	<i>Aileron</i>
2	<i>Elevator</i>	<i>Gimbal v</i>	<i>Gimbal v</i>	<i>Gun up/down</i>	<i>Elevator</i>
3	<i>Rudder</i>	<i>Steering</i>	<i>Steering</i>	<i>Steering</i>	<i>Rudder</i>
4	Throttle	Throttle	Throttle	Throttle	Throttle
5	Spoiler	Horn	Aux-1	Weapon sel.	Aux-1
6	Flap	Gear	Aux-2	Gear	Aux-2
7	Retract.Gear	Light	Aux-23	Aux-21	Retract.Gear
8	Towing dog	Full beam	Light	Light	Light

	Fixed-wing models	Vehicles	Ships / boats	Tanks	Helicopters
9	Wheel Brake	Sound	Headlight	Headlight	Switching channel-1
10	Gyro	Support Legs	ESP	Gyro	Gyro
11	Mixture		Horn	Horn	Switching channel-2
12	Aux-1	Aux-1	Aux-4	Aux-2	Aux-3
13	Aux-2	Aux-2	Aux-5	Aux-3	Aux-4
14	Aux-3	Aux-3	Aux-6	Aux-4	Collective
15	Aux-4	Aux-4	Aux-7	Aux-5	Thr.Limiter

5.4.2 Assign.Switches

Switches are controls that toggle functions or switch functions on/off.

Switches are assigned in the Setup > Assign.Switches menu (see section 4.3.7 "Assign.Switches" on page 106). This menu includes a list of the switchable functions provided in the software.

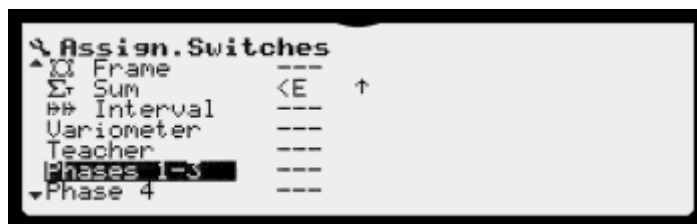

You can use this menu to customise the switch assignment according to your needs.

To assign a switch proceed as follows:

1. Move the input cursor to the control function you wish to assign a switch to.
2. Open the desired input field.
3. Assign the desired switch by operating it.

4. Set the switch to the position in which you wish the function to be enabled.
Alternatively, you can reverse the switch by pressing the **REV/CLR** button.
5. Close the input field.

List of switched functions

Switch	Description
DR aileron	Dual rate (switching between travels) for the aileron signal
DR elevator	Dual rate (switching between travels) for the elevator signal
DR rudder	Dual rate (switching between travels) for the rudder signal
CS/DTC	<ul style="list-style-type: none">• Combi-Switch (fixed-wing models)• Direct Throttle Control (helicopters)
Throttle-Cut	For switching the motor off.
Timer 1	Universal timer
Timer 2	Universal timer
Timer 3	Universal timer
Frame OPEN	"Opens" the frame of all the timers
Teacher	For transferring control functions to the student
Phases 1-3	For switching between the flight phases.
Phase 4	Switches from every other flight phase to phase 4
Vibration	Switches the vibration alarm off
Altimeter	Switches the altitude announcement on

MagicSwitch

The **PROFI TX** features 4 MagicSwitches.

A MagicSwitch is a logical switch which can be assigned to a switched or control like a real control.

It combines up to 4 switches (including other MagicSwitches and flight phases).

The first switches are combined by AND: The output of the MagicSwitch is only switched to "On" when all of the switches are ON. Unused inputs are considered switched on.

The 4th switch is combined in an OR function with the result of the AND group. If this switch is "ON" or the AND group is "ON", the MagicSwitch is "ON". When no switch is assigned, this input is considered to be switched off.

The MagicSwitch is switched on when all switches of the AND group that are assigned to it OR the 4th switch are switched on.

The MagicSwitch output switches with a configurable delay. OFF and ON delays can be configured separately.

Switches are assigned in the Setup > Assign.Switches > MagicSwitch menu (see page 108).



To assign a MagicSwitch proceed as follows:

1. Move the input cursor to a switch.
2. Open the desired input field next to it.
3. Assign the desired switch using the central wheel or by operating the switch.
The switches MS1, MS2 (MagicSwitch) and FP1 to FP4 (flight phases) cannot be assigned by operating a switch.
4. Set the switch to the ON position or select the ON position using the **REV/CLR** button.
5. Close the input field.

6 Operating the transmitter using the PC

You can use the supplied USB cable to connect the **PROFI TX** to any PC or tablet featuring an operating system that supports USB mass storage and an USB port that is compliant with the USB standard (4.5-5.5V / 500mA). Some laptops and tablets are not compliant with this standard.

The following functions are available when the transmitter is switched off (charging mode):

- Charging the battery; refer to section 2.4.1 "Charging the battery" on page 40 for detailed information
- Accessing the model memory on the SD card in the transmitter
- Updating the **PROFI TX** software
- Switching the transmitter on

The following functions are available when the transmitter is switched on (normal mode):

- Charging the battery
- Controlling a model flying simulator
- Switching the transmitter off

6.1 Connecting the transmitter

To connect the transmitter proceed as follows:

1. Lift the device (the recessed control for the sliding latch is located on the underside of the case).
2. Slide the latch to the left.
3. Connect the supplied USB cable to the mini USB socket on the **PROFI TX** and to the USB socket on the PC.



Die **PROFI TX** switches on automatically when it is supplied with charging voltage. The USB icon is shown on the right side of the screen and the state of charge and the charging current are displayed on the left.

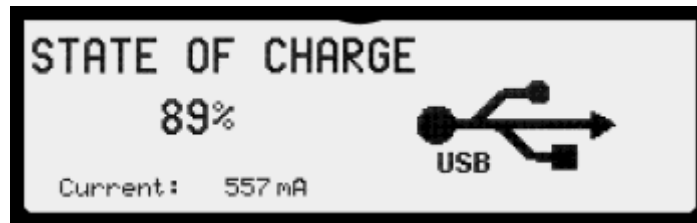

The **PROFI TX** logs into the PC as mass storage (drive) with the name "**PROFI TX**".

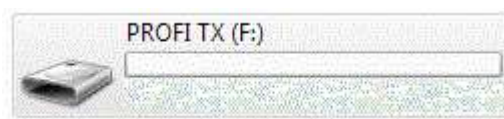

Open this "drive". It contains the following folders:



- DATA; contains the model memories, see section 6.2 "Editing "
- AUDIO; contains the speech output files
- UPDATE; see section 6.3 "Software update"

6.2 Editing model memories

The "DATA" folder on the PC contains the entire model memory of your **PROFI TX**. Files with the extension "MDL" contain one model data set each.

You can delete or archive the model data sets on the PC or edit the numbers to reorganise the memory.



Do not change the file name format. The **PROFI TX** only recognises file names in this format: PTXxxx.MDL (where "xxx" represents the memory number with leading zeros)

6.3 Software update

The "Update" folder is used for updating the firmware on your **PROFI TX** and for changing the language pair. You simply "place" the current update in this folder. The update is performed when the device is switched on again.

1. Download the latest firmware from the Downloads section of our home page.
2. Connect the transmitter to the PC.
3. When the transmitter is connected to the PC for the first time, you must wait until the automatic driver installation is completed.
4. Open the "**PROFI TX**" mass storage.
5. Place the update file in the "UPDATE" folder.
6. When updating from version 1 to version 2 with speech output, you must copy the entire content of the AUDIO folder (three subdirectories: DE, EN, FR) to the AUDIO folder of the **PROFI TX**. This process takes several minutes due to the amount of data.
7. Switch on the transmitter.

The update process starts automatically when an update file is found in the "Update" folder. The file name of the update is displayed on the transmitter screen. The annular light "rotates" until the update is completed.

Upon completion of the update process, the transmitter starts as usual. The update file is deleted automatically.

6.4 Switching to normal mode

In charging mode, the **PROFI TX** logs into the PC as mass storage with the name "**PROFI TX**".

Press and hold the power button until the annular ring is fully lit to switch to normal mode: The **PROFI TX** logs off from the PC as USB mass storage and logs in again as a game controller.

Now, you can access the status displays and menus as usual and program the transmitter.

6.5 Model flying simulator

You can use the **PROFI TX** to control a model flying simulator in two ways:

- Via USB cable
- Via M-LINK in conjunction with the MULTIFlight stick

In both cases, you have the following options:

- Would you like to work in simulator mode without configuring "Travel", "Expo" and "Trim"?
Switch ON "Training" in the Setup > Training menu (see page 99).
Select the Student mode. In this case, only unprocessed stick signals are used for controlling. It is not relevant which model memory is used. Only the stick assignment must match (see "Ctrl Mode" on page 104).
- Would you like to use "Trim", "D/R", "Expo", "Combi-Switch" and the "Ctrl.Mix" mixers?
Create a new model using the BASIC template (page 159) and change the model name (page 161), e.g. to Simulator. Safety check can be switched off.
From now on, use this model memory for simulator mode.
- Would you like to use "Expo", "D/R", "Trim", and "Combi-Switch" for the simulator?
Create a new model memory based on the BASIC model template (page 159). Change the model name (page 161), e.g. to Simulator.
Alternatively, you can copy the memory of a suitable model. Change the model name to avoid mix-ups. Do not use the memory of a real-world model: Settings that you configure for the simulator mode will not automatically suit your real-world model.

In simulator mode, all the functions on the servo side (mixers, curves, reverse) are switched off.

6.5.1 Via USB cable

If the **PROFI TX** transmitter is operating in normal mode and is connected to the PC via USB cable, it logs into the PC as a game controller. Upon first time use, Windows automatically installs the required drivers. This may take several minutes.

Neither the transmitter nor the PC must be switched off while the driver installation is in progress.

Once the installation is completed, the "Devices and Printers" menu contains the following additional entry:



If you are using our MULTIFlight simulator, no further steps are required. Calibration and assignment of the control channels match automatically.

For other simulators, you may have to perform a calibration and assign the control functions.

6.5.2 Using the MULTIFlight stick

Insert the MULTIFlight stick in a free USB socket on your PC. Wait until the driver installation process, which starts automatically, is completed.

Now, you have to bind stick and transmitter. Press and hold the MULTIFlight stick button until the yellow LED starts to flash. Switch on the transmitter. Open the Setup > M-LINK menu. Activate the binding as described on page 95.

The binding procedure has completed successfully when the LED on the MULTIFlight stick flashes slowly in regular intervals.

If you are using our MULTIFlight simulator, no further steps are required. Calibration and assignment of the control channels match automatically. The binding procedure can also be activated from the MULTIFlight simulator.

For other simulators, you may have to perform a calibration and assign the control functions.

6.5.3 MULTIFlight simulator

The simulator is available as freeware download on our website:

www.multiplex-rc.de

There are 2 options available for configuring the **PROFI TX** transmitter for simulator mode:

- Would you like to use "Trim", "D/R", "Expo", "Combi-Switch" and the "Ctrl.Mix" mixers?
Create a new model using the BASIC template (page 159) and change the model name (page 161), e.g. to Simulator. Safety check can be switched off.
From now on, use this model memory for simulator mode.
- Would you like to use only the stick signals, like a game controller?
Open the Setup > Training menu item. Leave Training switched off and set Mode to Student.

The MULTIFlight simulator automatically recognises the MULTIFlight stick and **PROFI TX**.

If you have questions regarding the use of **PROFI TX** with third-party simulators, please contact the manufacturer of the third-party simulator.

7 Creating and customising models

The following sections contain detailed descriptions of the menus and how the transmitter is operated using the keypad or central wheel:

- "The menus", see page 87
- "Operating the transmitter", see page 164

7.1 Fixed-wing models

7.1.1 The procedure in principle

A model memory for a glider-type model is created in this example. The procedure for power models is identical. For power models, only the Throttle and Spoiler controls are swapped and the mixer definition differs.

The following steps are required to ensure correct operation of the basic model functions:

1. Setting basic functions, see page 182
2. Setting rotation direction and maximum travels for the servos, see page 184

The basic functions of the model can be controlled once these steps are completed.

The basic functions can be extended and fine-tuned as follows:

3. Using ailerons as spoilers, see page 187
4. Using camber-changing flaps as spoilers, see page 188
5. Using further optimisation options, see page 188

7.1.2 Creating a new model in the transmitter

1. Switch on the transmitter.
1. Open the Memory main menu.
2. Open the New model menu.

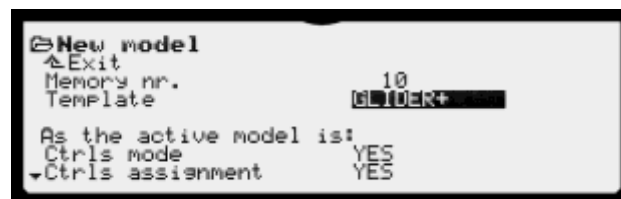

3. Select the GLIDER+ model template as *Template*. This is the most complex of all fixed-wing templates and thus offers more "training material" than the other templates.
4. Open the *Memory > Edit name* main menu and enter a unique and descriptive name for the model (see section 4.8.4 "Edit" on page 161).
5. Assign the desired controls (actuators) to the control functions in the *Setup > Assign.Controls* menu (see section 4.3.6 "Assign.Controls" on page 104).



Pay attention to the zero positions when assigning "Throttle" and "Spoiler"! The arrow next to the control name (F>, <E, etc.) points in the direction of the zero position.

6. Connect the servos as shown in the following figure.

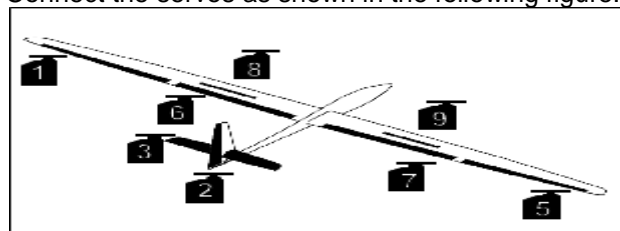

Do not connect the electric motors yet!

- Perform the binding procedure (see section "Binding" on page 47).

7.1.3 Adjusting rotation direction and maximum travels for the servos / control surfaces

NOTICE

Use electronic means as little as possible to reduce the servo travels. Otherwise, you will forfeit servo resolution!

If possible, implement major changes using control surface linkages.

7.1.3.1 Configuring aileron differential

1. Open the Mixer > Differnt.Ail menu.
2. Set Mode to ON and Differnt.Ail to + or -100%.

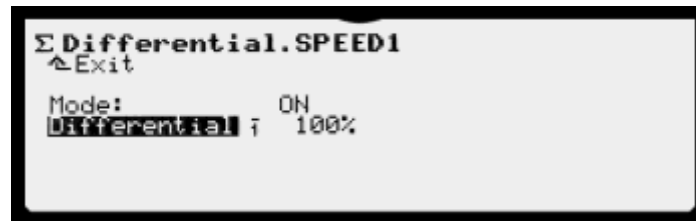

3. Set aileron travel to the left.
In case of stick travel to the left, only the left aileron should move.
If the right control surface moves, reverse the differential using the **REV/CLR** button (-100%).
4. Now, reset Differnt.Ail to 50% (+ or -). The suitable value is determined later in flight. If the transmitter has a digi-adjuster, you can allocate the differential for the set value to it (see section "Allocating a set value" on page 168).

7.1.3.2 Adjusting control surface travel and maximum servo travel

The AILERONS+ mixer is defined as follows:

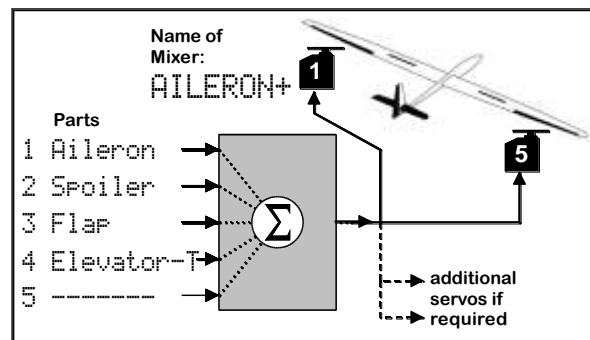
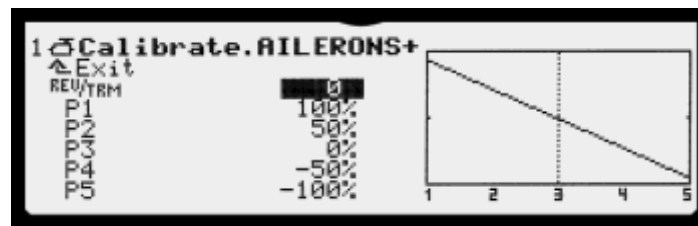
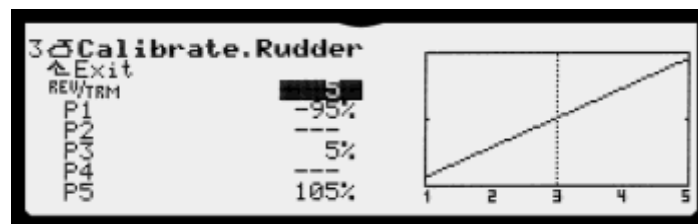



Figure 18: Principle of the AILERONS+ mixer

1. Open the Servo > Calibrate > 1: AILERONS+ menu.



2. Open the REV/TRM parameter and set aileron travel to the left.
If the left aileron does not move up, reverse the servo using the REV/CLR button.
3. Move the aileron stick to the centre position. Move the control surface to the neutral position using the central wheel or the + / - buttons.
The setting range is +/-10%. Offsets exceeding 5% should be corrected mechanically.
4. Open the input field P1.



5. Press the button: .
Both ailerons move to maximum.
6. Choose a P1 setting so that the left aileron (servo 1) stops a little way from the mechanical stop.
7. Now open P5.
8. Press the F button.
Both ailerons move to the opposite maximum.
9. Set the positive travel on the left aileron (servo 1) to a safe value.
10. You can use the points P2 and P4 to linearise the control curve, if required.
P3 shifts the neutral position without changing the other points.
11. Open the Servo > Calibrate > 5: AILERONS+ menu.
12. Open the REV/TRM parameter and set aileron travel to the right.
If the left aileron does not move up, reverse the servo using the REV/CLR button.
13. Move the aileron stick to the centre position. Move the control surface to the neutral position using the central wheel or the + / - buttons.

The setting range is $\pm 10\%$. Offsets exceeding 5% should be corrected mechanically.

14. Choose a P1 and P5 setting so that control surface travels on the right aileron are identical to those on the left aileron:

- Open the input field P1.
- Press the \oplus button.

Both ailerons move to the negative maximum.

- Use P1 to align the negative travel of the right aileron with that of the left aileron.
- Open the input field P5.
- Press the \oplus button.

Both ailerons move to the positive maximum.

- Use P5 to align the positive travel of the right aileron with that of the left aileron.
- Repeat these steps for the points P2 and P4. P3 shifts the neutral position without changing the other points.

7.1.3.3 Adjusting elevators

1. Open the Servo > Calibrate > 2: ELEVATOR+ menu.

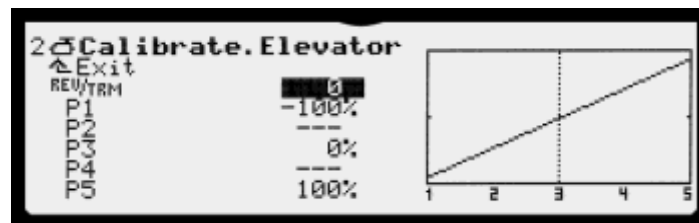

2. Open the REV/TRM parameter and apply up-elevator.

If the elevator moves down, reverse the servo using the **REV/CLR** button.

3. Move the control surface to the neutral position using the central wheel or the **+ / -** buttons.

The setting range is $\pm 10\%$. Offsets exceeding 5% should be corrected mechanically.

4. Correct the maximum servo travels using P1 and P5 (see section 7.1.3.2 "Adjusting control surface travel and maximum servo travel" on page 184).

7.1.3.4 Adjusting rudders

1. Open the Servo > Calibrate > 2: Rudder menu.

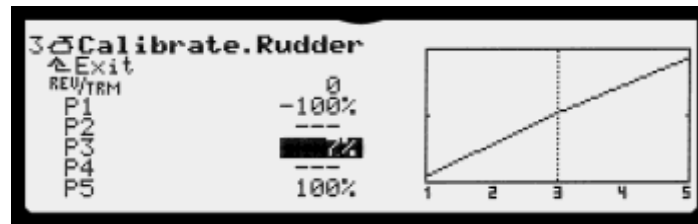

2. Open the REV/TRM parameter and set rudder travel to the left. If the rudder does not move to the left, reverse the servo using the **REV/CLR** button.
3. Move the control surface to the neutral position using the central wheel or the + / - buttons. The setting range is +/-10%. Offsets exceeding 5% should be corrected mechanically.
4. Correct the maximum servo travels using P1 and P5 so that no mechanical stop is reached (see section 7.1.3.2 "Adjusting control surface travel and maximum servo travel" on page 184).

7.1.3.5 Adjusting flaps

1. If your model has inboard flaps perform step 1 to 4 in section 7.1.3.1 "Configuring aileron differential" on page 184 for the inboard flaps.
2. If your model features mechanical airbrakes, extend them using the assigned control. Check and correct the actuation direction in the Servo > Calibrate menu for servos 8 and 9.

7.1.3.6 Adjusting the power system

1. If your model has a power system, check the actuation direction of the throttle channel.
2. If required, adjust the rotation direction using the **REV/CLR** button.



After these steps, the main setup is completed:

- The control surfaces move in the correct direction.
- Maximum travels and neutral positions are adjusted.
- The ailerons move synchronously.

7.1.4 Using ailerons as spoilers

To raise the ailerons as airbrakes (spoilers) proceed as follows:

1. Open the Mixer > AILERONS+ menu.

2. Set the value for the `Spoiler > Travel` parameter to 100%.
3. Move the control for the Spoiler control function to maximum.
If the ailerons move down, reverse the travel using the **REV/CLR** button.
4. Reduce the value for the `Aileron > Travel` parameter to a value significantly below the spoiler travel. Use the manufacturer's specifications for your model as a guideline.
5. Set "Mode" to "+SPOILER" in the `Mixer > Differnt.Ail` menu. Set the differential to a suitable value (see section 7.1.3.1 "Configuring aileron differential" on page 184).

7.1.5 Using camber-changing flaps as spoilers

If your model has inboard flaps, you should use the camber-changing flaps also as airbrakes (spoilers):

1. Open the `Mixer > FLAPS+` menu.
2. Set the value for the `Spoiler > Travel` parameter to 100%.
3. Move the control for the Spoiler control function to maximum.
If both flaps do not move down, reverse the travel using the **REV/CLR** button.
4. Reduce both travel distances, up and down, of the aileron.
In this mixer, you can adjust the travel distances of the ailerons separately. The flaps should have the travel recommended by the manufacturer of your model.
5. Configure the differential in the `Mixer > Differnt.Ail` menu (see section 7.1.3.1 "Configuring aileron differential" on page 184).

7.1.6 Optimisation

Your model is now configured and ready for flying. The following optimisation options are available:

- **Camber-changing flaps:**
Increase the travels for `Flap` in the mixers `AILERONS+` and `FLAPS+` (see section 4.5.2.4 "Mixers on the servo side" on page 144).
- **Snap flap:**
Increase the travels for `Elevator` in the mixers `AILERONS+` and `FLAPS+`.
You can configure the mixer input as switchable by assigning a switch to the `Elevator` mixer input in the `SETUP > Define mixer > AILERONS+` menu

and the `SETUP > Define mixer > FLAPS+` menu (see section 4.3.8 "Define mixer" on page 110).

- Elevator compensation:

You can mix `Spoiler`, `Flap`, and `Throttle` into the elevator using the `Mixer > ELEVATOR+` menu (see section 4.5.2.4 "Mixers on the servo side" on page 144).

- Combi-Switch:

- Define a switch in the `Setup > Assign.Switches` menu and assign it in the `Mixer > Combi-Switch` menu (see section 4.3.8 "Define mixer" on page 110).

- Other control functions:

If required, assign other control functions to unused servo channels in the `Servo > Assign` menu (see section 4.6.2 "Assign" on page 149).

- V-tail:

In the `Servo > Assign` menu, reassign servo channels 2 and 3 from `ELEVATOR+ / Rudder` to `V-TAIL+`.

Then, adjust the rotation direction and travels in the `Mixer > V-TAIL+` menu (see section 4.5.2.4 "Mixers on the servo side" on page 144).

- Flight phases:

Assign a switch to flight phases 1-3 in the `Setup > Assign.Switches` menu. The 4th phase is activated by assigning a switch to `Phase 4`.

Choose a suitable name for each flight phase in the `Setup > Flight Phases` menu. Set the transition time to the next phase using the `Slow` parameter (see section 4.3.3 "Flight phases" on page 97).

- Flight phases as virtual switches:

You can also assign flight phases as virtual switches, e.g. if you prefer to use different mixers in some flight phases. The virtual switch is ON when the associated flight phase is active.

- Control functions:

Further options—many of which are flight phase specific—are available in the `ControlFunctions` menu (see section 4.4 "ControlFunctions main menu" on page 118).

7.2 Helicopter models

7.2.1 The procedure in principle

A model memory for a helicopter with 120° CCPM main rotor and electric power system is created in this example.

The following steps are required to ensure correct operation of the basic model functions:

1. Creating a new model in the transmitter, see page 190
2. Preparing controls and switches, see page 191
3. Checking and changing servo assignment, see page 194
4. Checking and adjusting the main rotor, see page 194
5. Checking and adjusting the tail rotor, see page 199

The basic functions of the model, i.e. Aileron, Elevator, Rudder, and Throttle / Collective, can be controlled once these steps are completed.

The basic functions can be extended and fine-tuned as follows:

6. Working with flight phases, see page 205

7.2.2 Creating a new model in the transmitter

1. Open the `Memory` main menu.
2. Switch to a similar model in the `Select` menu. If no model is available yet or if the current model is quite similar to the new model, simply proceed with the next step.
3. Open the `New model` menu in the `Memory` main menu.

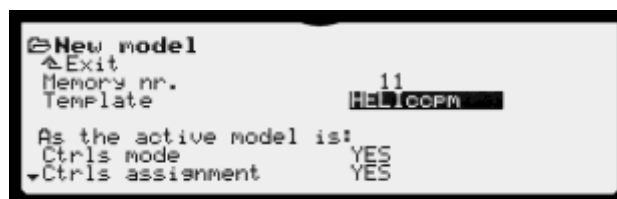

Selecting a template



Thanks to pre-defined model templates (see page 55) new models can be created more easily and quickly since the basic configuration is more or less completed by selecting the template.

You can use the `Memory > Edit name` menu to find out which template was used for model creation.

4. Select the `HELICCPM` model template for the `Template` parameter.

Inheriting parameters from the active model

5. Select the data to be inherited from the currently active model.
 - a. `Ctrl Mode`: Usually, the basic control functions will always remain on the same stick axes. So, keep the switch setting "ON".
 - b. `Ctrls assignment`: When you select "ON", the assignments of controls to control functions are inherited from the current model. When set to "OFF", they are inherited from the template.
 - c. `Switch assignment`: When you select "ON", the assignments of switches to switched functions are inherited from the current model. When set to "OFF", they are inherited from the template.
 - d. `Names of Controls`: When you select "ON", the names of the control functions are inherited from the current model. When set to "OFF", they are inherited from the template. If you changed the names in the current model and you would like to inherit these names, "ON" should be selected. Otherwise, setting the switch to "OFF" is preferable.
 - e. `Sensor names`: When you select "ON", the names of the sensors are inherited from the current model. When set to "OFF", they are inherited from the template. If you changed the names in the current model and you would like to inherit them, "ON" should be selected. Otherwise, setting the switch to "OFF" is preferable.

The device stores your selection. In most cases, you just have to check the selection switches.

Confirming settings

6. Confirm the setting with `OK`: The model memory is created and immediately activated. The display automatically switches to safety check and status display.

Editing the model name

The new model that is created has the same name as the template used: HELIccpm. For easier reference, you should change the name to the actual model name:

7. Open the Memory > Edit name menu.
8. Enter a name (max. 16 characters) that clearly identifies the model. Refer to page 161 for details.

The creation of a new model in the memory is now completed. These settings determine the following in the model memory:

Receiver output assignment

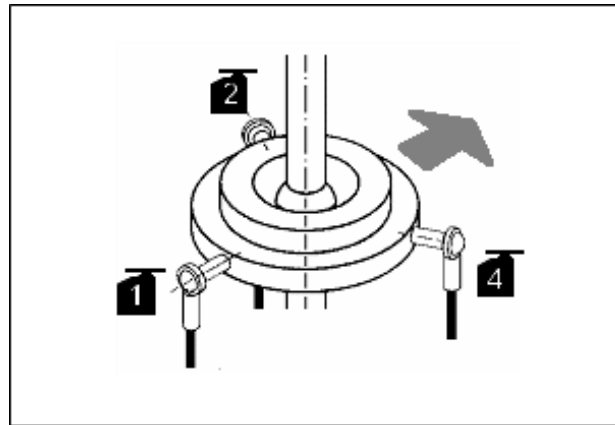

- Servo 1 to 6 are pre-defined
- The servo assignments can be changed and amended as required (Servo > Assign menu).

Controls assignment from the template

Controls are assigned to control functions in the Setup > Assign.Controls menu:

Function	Control	
Throttle ↓*	↔*	Collective is assigned to the same control as Throttle

Gyro	<E	↕*	Left-hand slider for gyro sensitivity
Thr.Limiter	F>	↕*	Right-hand slider for Thr.Limiter

Switch assignment

The Setup > Assign.Switches menu contains:

Function	Switch		
CS/DTC		You can use this switch to alternate from the throttle curve to direct throttle control using the throttle limiter. Useful for configuring I.C. engines.	
Throttle-Cut		Do not use any button here!	
Σ Timer2	F	↑	Switch for timer 2, controlled by control F> (throttle limiter). Timer 2 records the motor run time as a sum timer.
Phase 4			Switch for the main flight phase = AUTOROT.
Phases 1-3			Flight phases switch

Unused switches are marked with " --- " and are not listed here.

- Assign a switch to all the switched functions that you intend to use.



You can now perform the first functional test with the servo monitor. The model is not required for this test (see section 4.6.4 "Test run" on page 151).

7.2.3 Preparing controls and switches

Checking / changing the minimum control positions for idle / collective pitch and throttle limiter

In the templates for helicopters, minimum idle / collective pitch is set to "back" (↕ arrow next to the identifier). The minimum position for the throttle limiter is also set to "back".

To change the setting to "front" proceed as follows:

1. Open the Setup main menu.
2. Open the Assign.Controls menu.
3. Select the control function, e.g. Throttle.



4. Operate the throttle stick vigorously. Leave it in idle position.
The direction arrow points to the current position of the stick.



WARNING

Never change the assignments and/or rotation direction of controls and switches when the model is switched on. Power systems and servos may start up unexpectedly and cause damage.

5. Confirm the change by pressing ENTER.
Proceed as described above to change the minimum position for the throttle limiter.

7.2.4 Checking and changing servo assignment

The servo assignment defines:

- The receiver output controlling the servo
- The number of curve points (2, 3, or 5) used for adjusting servo travel



Defaults

The main rotor servos and the servo gyro have 3 curve points (the centre can also be set). Throttle and tail rotor have 2 curve points for a linear characteristic (only end-points must be set).

Procedure

1. Open the Servo main menu.
2. Open the Assign menu.
In this menu, the assignments for all the receiver outputs can be changed as required.

In the following example, servos 3 and 4 are swapped so that all the main rotor servos are in sequence.

3. Select servo 3 TAIL ROTOR.



4. Press ENTER. Use the central wheel to set MAINROTOR-R.
5. Press ENTER. Set the number of curve points to 3P.
6. Press ENTER. Select servo 4.
7. Press ENTER. Use the central wheel to set TAIL ROTOR.



8. Set the number of curve points to 2P. Only the end positions then require setting. This always yields a straight line between the points.



9. Confirm the change by pressing ENTER.
Servo 3 and servo 4 are now swapped. All the main rotor servos are in sequence.

7.2.5 Checking and adjusting the main rotor

CAUTION

Secure the model when you set the rotation direction, centre, and travels for the servos to prevent danger or damage due to unexpected reactions.

7.2.5.1 Checking / changing direction of servo rotation on the main rotor

The directions of travel for the servos must be checked and changed (if required) before centre and travel are set.



- For electric helicopters: disconnect the motor!
- Move the collective pitch stick approximately to the centre position.
- Then, switch the receive system ON.



Start with the Collective function!

If the swashplate responds correctly when you move the collective pitch stick and if the main rotor servos are connected correctly, the directions of travel for aileron and elevator must also be correct.

To perform the check move the collective pitch stick in the direction of maximum collective pitch (climbing) and observe if the swashplate moves up and remains horizontal.

Changing the rotation direction

1. Open the `Servo` main menu.
2. Open the `Calibrate` menu.
3. Select a servo.
4. Select `REV/TRM` and open the parameter.

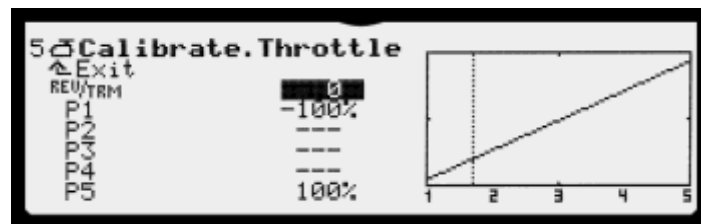

5. Adjust the direction of servo rotation using the **REV/CLR** button. The effect of the change is immediately visible in the graph (the curve reverses).
6. If the rotation direction is correct, confirm the change and exit the menu.
7. Select the next servo to be edited.



Make sure that the rotation direction for all the servos is correct before you start to set travel and centre. If the rotation direction is changed later, a re-calibration is required.

7.2.5.2 Calibrating servos: setting centre and maximum travel

Use the `Servo > Calibrate` menu (see page 146) to adjust the travels (P1 and P5) and the centres (P3) for all the servos so that the servos assume the correct idle position, move evenly across their range of travel, and reach the appropriate end-travels.



If you wish your models to fly accurately, precise servo calibration is essential!

The travel you set at this point cannot be exceeded (travel limit).

Always set the largest travel which the servo will be required to carry out.

Setting the centre

1. Open the `Servo` main menu.
2. Open the `Calibrate` menu.
3. Select a servo.
4. Select the `P3` menu item and open the parameter.
5. Press the `F` button to allocate the centre. This passes the Centre value, 0%, to all the servos with the same basic function. This enables you to set the centre for the current servo regardless of the stick position.

Moving the stick, or pressing the `F` button again erases the allocation!



Note regarding "allocation"

Allocating in this way saves you the bother of holding the stick at one end-point, and enables you to use both hands in order to measure the control surface travel on the model. If required, you can make corrections using the central wheel.

Calibrating multiple servos with the same function:

Example: Servos 1, 2, and 4 are assigned as `MAINROTOR-X` (mixed function). Point `P3` is opened in the `Calibrate` menu for servo 1. When you now allocate the centre using the `F` button, all the swashplate servos will immediately move to the centre. At this point, you can use the central wheel to adjust the current servo to match the other two.

6. Use the wheel to set the servo to the desired centre. Any changes you make are immediately visible on the model itself.
7. If the centre is correct, confirm the change and exit the menu.
8. Select the next servo to be edited.

Adjusting the maximum servo travel (control surface travel)



At this point, set the maximum required value for blade deflection; this is generally the auto-rotation value. The smaller values required for normal flying can be set for the individual flight phases in the `ControlFunctions` menu under `Collective`.

1. Open the `Servo` main menu.
2. Open the `Calibrate` menu.
3. Select a servo.
4. Select the `P1` menu item and open the parameter.

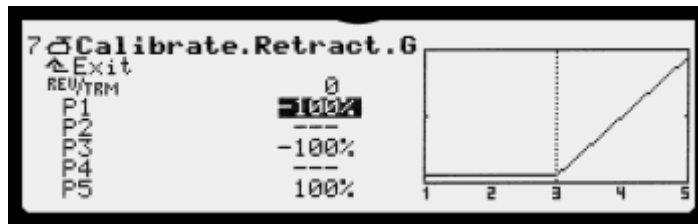

5. Press the `F` button. All the swashplate servos now assume this position.
This enables you to set the servo travel regardless of control position and trim.
Pressing the `F` button again enables the servos.



Maximum servo travel = 110%

If required, servo travel can be increased to up to 110% on both sides.

6. Complete the calibration for `P1`.
7. Repeat the procedure for point `P5`, starting from step 4.
8. Exit the menu and set up the other servos accordingly.

7.2.6 Checking and adjusting the tail rotor

7.2.6.1 Checking / changing the direction of servo rotation for the tail rotor

The direction of servo travel must be checked and changed (if required) before centre and travel are set.



When entering the basic settings do not connect the tail rotor servo via the gyro, but directly to the respective receiver output. This ensures that the gyro has no effect on your settings.

Move the rudder stick to the left, and observe the response of the tail rotor. Does the pitch angle of the blades change in the correct direction? Otherwise, reverse the tail rotor servo as described on page 147.

7.2.6.2 TAIL ROTOR mixer

The **TAIL ROTOR** mixer of the **PROFI TX** conceals the function "static tail rotor compensation", which is also sometimes referred to as REVO-MIX (revolution mixer). The **TAIL ROTOR** mixer is always displayed in the Mixer main menu when you create a model based on the model templates **HELI_{mech.}** or **HELI_{ccpm.}**

When a helicopter transitions from hovering to a climb or descent, the torque which the tail rotor has to compensate for becomes larger or smaller, with the result that the model yaws in one direction. Once set up correctly, the **TAIL ROTOR** mixer compensates for these torque fluctuations, and prevents the model yawing. It also eases the task of the gyro system, so that you can set a high sensitivity value and thereby obtain very good tail rotor stabilisation.

For this, the following parameters are required in the **TAIL ROTOR** menu:

Offset

To compensate for the torque at 0° collective pitch (main rotor), a small tail rotor pitch angle (= **Offset**) is required. The value can be set separately in each flight phase. This will be necessary if you use different system speeds in the various flight phases.

In the flight phase **AUTOROT** (auto-rotation) the **Offset** parameter can be changed so that no tail rotor pitch is present at all. This is particularly important if your model helicopter features a driven tail rotor.

Coll.+ / Coll.- (REVO-MIX)

You can use the `Coll.+ / Coll.-` parameters to set the collective pitch mixers for the tail rotor separately for climb and descent, and for each flight phase:

- `Coll.+`: correction for climbing
- `Coll.-`: correction for descending

The exact values can only be established through a programme of flight testing, and vary according to many parameters.

Origin

The origin for the static tail rotor compensation mixer is set under `Origin`. Starting from this collective pitch setting angle in the direction of "climbing", the "Collective -> Tail rotor" mixer is added using the value set for `Coll.+`. The value set for `Coll.-` is applied in the opposite direction (descending).

1. Move the collective pitch stick to the position corresponding to 0° collective pitch (use a rotor blade gauge if available).



The configuration of the collective pitch curve must be completed, first.

The value for `Collective` (last line) cannot be changed. It shows the current position of the collective pitch stick, and serves as an aid during setup. Use the throttle / collective pitch stick to set the main rotor blades to a pitch angle of zero. Apply this value to the `Origin` parameter.

Configuring rudder differential

The purpose of the `Rudd.Diff.` parameter is to reduce the tail rotor travel in one direction. This is necessary if the model behaves differently when yawing (rudder commands) to left and right (rotational speed). Since the tail rotor has to counteract the torque generated by the main rotor, "Rudder" is usually weaker when the model is required to turn against the rotation direction of the main rotor.

A separate value can be set for each flight phase.

7.2.7 Gyro

The Gyro control function is intended for gyro systems which allow radio-controlled configuration of the sensitivity via a servo channel.

If Gyro is not assigned to a servo channel, this function is not available in the Controls menu.

1. Open the Controls main menu.
2. Open the Gyro menu.

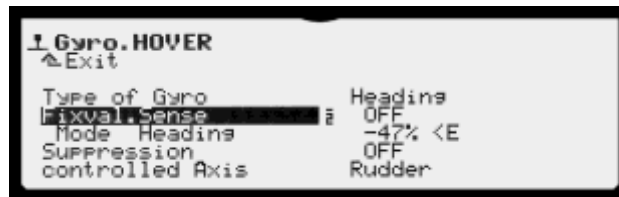

The gyro type `Heading` is selected by default in the model templates. The fixed value for sensitivity is switched off (`OFF`). Gyro sensitivity is controlled using the assigned control. In the helicopter templates, this control is always the left-hand slider (`<E`). The next line shows the operating mode (`Mode`), the value provided by the control in %, and the identifier for the control (`<E`) for heading gyros. `Rudder` is by default set as `controlled Axis`.

Heading gyros have two operating modes. The prefix of the sensitivity setting is used for switching between these modes. Minus switches to `Heading-hold` mode, plus switches to `Damping` mode.

In `Heading-hold` mode, rudder trim and tail rotor mixer (`TAIL ROTOR`) are switched off.

The gyro is assigned to servo channel 6 in all the helicopter templates. Refer to section 4.4.5 "Gyro" on page 128 for more information.

- Damping mode

The gyro operates in `Damping` mode if sensitivity is set to positive values.



- The gyro operates in `Heading-hold` mode if you set the sensitivity to a negative value.
- Controls mode

In controls mode, gyro sensitivity can only be set manually using the Gyro control function (factory setting: slider E). To this end, Fixval.Sense must be set to OFF. The next line now shows the position (50%) and control (<E):

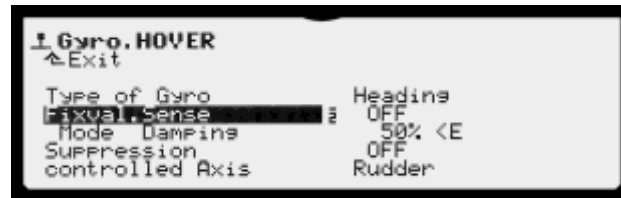

7.2.7.1 Setting gyro suppression

Without suppression, the gyro would also damp out intentional control commands. Many gyros reduce their effect (sensitivity) automatically when the pilot gives a deliberate command. Unfortunately, the trim is taken into account. For this reason, you should deactivate automatic suppression on your gyro (if possible) and use transmitter suppression (read the appropriate notes in the gyro system operating instructions!).

The gyro effect is suppressed in proportion to the travel of the control that was set in addition to the controlled Axis. In case of helicopters, this control is always Rudder.



- If Suppression = 100%, the gyro effect (Fixval.Sense) is reduced to zero (= gyro OFF) at full travel of the Rudder control.
- If Suppression = 200%, gyro sensitivity is reduced to zero (= gyro OFF) at half travel of the control.
- If Suppression = 50%, gyro sensitivity at full travel is 50% of the original value setting.

Suppression is only effective in the Damping gyro mode, regardless of the flight phase.

NOTICE

Before flying a model, make sure that the gyro counteracts the rotational movement of the model in Damping mode. A gyro operating in the wrong direction renders will render it uncontrollably unstable!

7.2.8 Throttle

The Throttle control function can be adjusted using 7 curve points or using a fixed value when the electric power system operates in Governor mode.

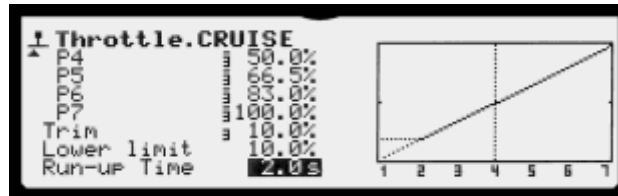

Each flight phase has a specific curve. Only in the AUTOROT flight phase, all the curve points have the same value (yielding a straight line).

To assist model adjustment when the motor is running Throttle can be limited towards full throttle using a limiter. In all the helicopter templates, the right-hand slider F> is used for this function (changing; see page 104). During adjustment, reduce the limiter to a value that prevents the model from taking off.

- The purpose of the throttle-cut switch is to switch off the power system quickly in case of an emergency.

NOTICE

No Throttle-Cut switch is assigned in the templates. You must assign a switch before you start operating your model (see page 109). **Always use a dip-switch. If a button were used, electric motors would start up again when the button is released!**

- The limiter (upper dashed horizontal line) limits the throttle upwards to allow the model to be adjusted (slider at the top = no limit). The sum of lower

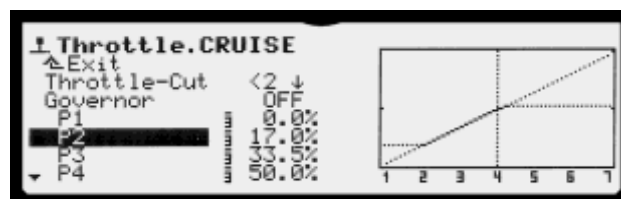

limit + trim^{FPH} restricts Throttle downwards as the idle limit for I.C. engines (upper dashed horizontal line).

- The idle limit is switched off in the AUTOROT flight phase, even if flight phase specific trim was or is set to 0.0%.

Sometimes, it can be useful to operate the throttle directly without any restrictions. To do so, assign a switch to the CS/DTC switched function as described on

page 109. When this switch is in ON position, the limiter controls the throttle directly.

7.2.9 Setting the collective pitch curve



Does not apply to the FUNCOPTER template!

The FUNCOPTER is throttle-controlled. It does not require collective pitch control.

For helicopter models, the collective pitch curve is set in the `ControlFunctions` menu under `Collective`. For each of the flight phases a separate collective pitch curve can be configured to achieve optimum adaptation to the respective flight phase:

Each curve point can be allocated using the central wheel to allow in-flight configuration (see section 4.4.6 "Collective" on page 131).

Example 1: collective pitch curve in the HOVER flight phase

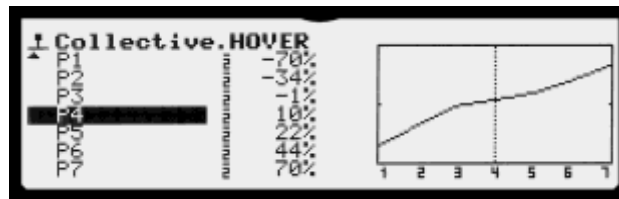

A "flatter" collective pitch curve from hover collective pitch (stick centre) to collective pitch minimum (descent) helps to provide fine control during the hover and promote accurate landing of the model.

In the "climb" area (stick centre to collective pitch maximum) only 70% of possible collective pitch travel is used. This also contributes to fine control during the hover.

Example 2: collective pitch curve in the CRUISE flight phase

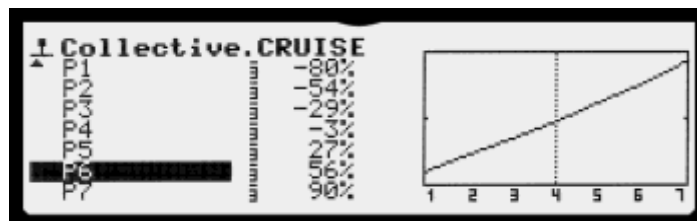

Linear, symmetrical collective pitch curve for the same collective pitch control when climbing and descending; overall higher maximum collective pitch values since a higher system speed is typically set (throttle curve) allowing higher climbing performance:

7.2.10 Working with flight phases

Requirement

To allow working with flight phases, at least one switch must be assigned in the Setup > Assign.Switches menu (either for Phase 4 or Phases 1-3). Otherwise, the transmitter always operates in Phase 1.

For each flight phase, you can customise the control characteristics on the transmitter according to the requirements of the model (e.g. reduced control travels for HOVER, maximum control travels for collective pitch for AUTOROT, V-shaped throttle curve for 3D flying). In the control function menus, all settings that can differ between flight phases are accompanied by the respective identifying number for the flight phase.

Example: Aileron

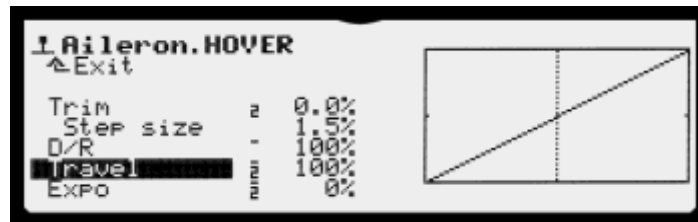

Flight phase specific settings can only be configured for control functions and control mixers. The servo settings are identical in all the flight phases.

7.2.10.1 Defaults in the Flight phases menu

1. Open the Setup main menu.
2. Open the Flight Phases menu.

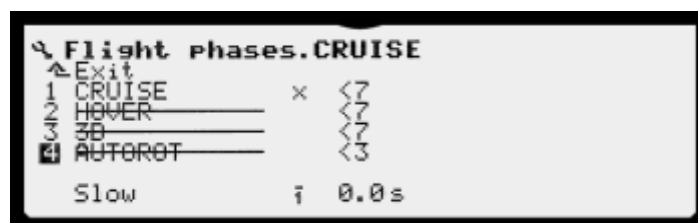

Three dashes "---" next to the flight phases indicate that no switch has been assigned for switching between flight phases. In this case, flight phase 1 HOVER is automatically selected and marked as the active flight phase (x).

Names are pre-assigned to all four possible flight phases. However, those can be edited using the + / - button or the central wheel.

7.2.10.2 Assigning switches for flight phases

At least one of the two switches must be assigned before you can use different control settings in the flight phases:

1. Open the `Setup` main menu.
2. Open the `Assign.Switches` menu.
3. Select `Phases 1-3` and open the parameter.
4. Move switch I to the ON position (* must be visible).

To use all four flight phases a switch must also be assigned to `Phase 4`.

Phase 4 switch (assign a 2-position switch)

If this switch is in ON position (marked with * during assignment), flight phase 4 is activated. For helicopters, this flight phase is assigned to "auto-rotation". The position of the switch for flight phases 1-3 does not have any effect in this case.

If no switch is assigned to `Phases 1-3`, you can only switch between phase 1 and 4 by operating the `Phase 4` switch.

Phases 1-3 switch (assign a 3-position switch)

You can use this switch to activate `Phase 1, 2, or 3`, provided that the `Phase 4` switch is in OFF position.

7.2.10.3 Disabling / enabling flight phases

You can disable flight phases that have not yet been set. Disabled phases cannot be activated even if a switch is assigned to them. If the switch is moved to a position for a disabled flight phase, the operator is alerted by a message (announcement every minute, for as long as the switch remains in this position).



The active flight phase—marked with an x—cannot be disabled.

1. Open the `Setup` main menu.
 2. Open the `Flight Phases` menu.
-

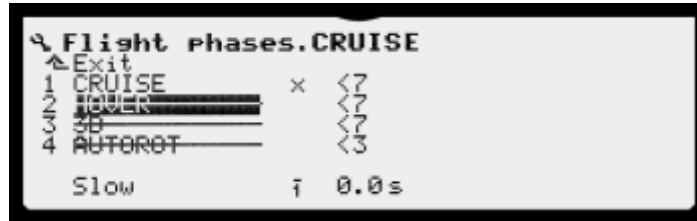

3. Select the respective flight phase in the menu.
4. Every time you press the **REV/CLR** button, the flight phase toggles between disabled and enabled.
5. Confirm the change.

7.2.10.4 Copying flight phases

Once you have established the correct settings in one flight phase, you can copy the values to another flight phase and then modify them. This eliminates the need for re-entering all the settings from scratch.



Only the active flight phase can be copied.

1. Open the **Setup** main menu.
2. Open the **Flight Phases** menu.
3. Select the active flight phase (with the **X**) and press the **ENTER** button twice: **A C** (for "copy") is now shown above the **X**.
4. Select the copy target by moving the **C** to the respective line.

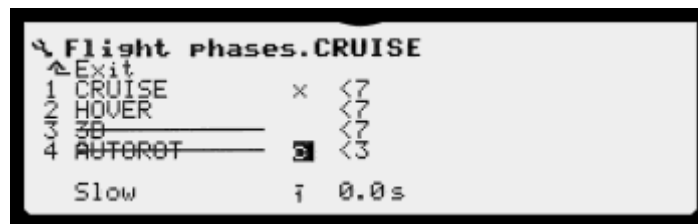

5. Press the **ENTER** button.
The cursor returns to the number of the active flight phase. Except for the run times, all the flight phase specific settings are now identical to those of the active flight phase.

7.2.10.5 Changing flight phase names

You can select any of the 13 pre-set names for the flight phases:

1	NORMAL	6	SPEED1	11	HOVER
---	--------	---	--------	----	-------

2	START1	7	SPEED2	12	3D
3	START2	8	CRUISE	13	ACRO
4	THERMAL1	9	LANDING		
5	THERMAL2	10	AUTOROT		

After activating the input field for the name, select a name by pressing the **+ / -** buttons or by using the central wheel.

Two exceptions apply to the **AUTOROT** name: There is no transition delay when switching to this flight phase and the lower throttle limit is overridden.

7.2.10.6 Setting the transition time

When switching between flight phases, you can choose to apply a delay time of 0.1 to 6.0 seconds for a smooth transition.

1. Open the Setup main menu.
2. Open the Flight Phases menu.
3. Select the Slow menu item.
4. Switch to the desired flight phase.
5. Press the **+ / -** buttons or use the central wheel to set the transition time.
6. Confirm your settings.

8 Speech output & sounds

8.1 Volume

The transmitter volume can be set by either choosing a fixed value or by configuring a freely assignable control. The variometer volume is configured separately. Refer to section 4.3.1 "Volume" on page 95 for details.

8.2 During startup

A tune can be played when the device is switched on. You can switch this feature on or off in the `Setup > Transmitter > Sounds` menu (see page 114).

8.3 Battery monitor

You can use the `Setup > Transmitter` menu to set the time to empty value at which the remaining operating time of the PROFI TX will start to be announced. Refer to page 114 for details.

8.4 Announcing trim

You can have the device announce the trim position (increments) after trimming. You can switch this option on or off in the `Setup > Transmitter > Sounds` menu (see page 114).

8.5 Announcing flight phases

After switching to an enabled flight phase, the name of the flight phase is announced. If the flight phase is disabled, the current flight phase is retained and the message "flight phase disabled" is announced.

8.6 Announcing sensor values

You can enable the value of each of the 16 sensor channels for announcing (see section 4.3.5.2 "Announce & Alert" on page 103).

The values of the enabled sensors are then announced in sequence in one block. The break interval between the blocks can be set to a value between 30 and 180 seconds.

If a sensor triggers an alarm, it is announced immediately even if it is not enabled for announcing. As long as the alarm persists, it is included in the sequence of the announcement block in accordance with its sensor address.

When a control is used for setting the volume (see section 4.3.1 "Volume" on page 95), the announcement sequence can be restarted by muting the volume and then turning it up again.

8.7 Announcing altitude

If your model includes an altitude sensor, you can have the device announce the altitude. 4 options are available:

1. Announcement at intervals

The altitude is announced at intervals of 3 to 30 seconds.

2. Announcement by grid

A grid is applied to the altitude values. When the altitude changes to a different field in the grid, the altitude is announced. This method is activated when the announcement interval is switched off.

Altitude	Grid
up to 100m	25m
up to 350m	50m
400m and higher	100m

3. A switch can be assigned to the altitude announcement (see section 4.3.7.3 "Assign.Switches" on page 109). The altitude is announced immediately after the announcement feature is switched on. Then, the altitude is announced at intervals or by grid as long as the switch is set to ON. Use a button to call up the altitude if you do not wish to have the altitude announced continually.
4. The volume of the variometer tone is configured separately. You can also assign a control (see section 4.3.1 "Volume" on page 95). When you mute the variometer volume and then turn it up again, the altitude is announced once.

Refer to section 4.3.5.1 "Vario. & Altitude" on page 102 for more information.

8.8 Other announcements

8.8.1 Teacher / student

When the teacher transfers control to the student, the message "student controls" is announced if a connection to the student transmitter is established.

If the connection to the student is lost, control is returned to the teacher. The warning message "student offline" is announced.

8.8.2 Safety check

The announcement can be switched on or off in the `Setup > Transmitter > Sounds` menu (see page 114).

9 Maintenance and care

The transmitter does not require any special maintenance or care.

However, we strongly recommend that you have the transmitter checked by an authorised MULTIPLEX Service Centre at regular intervals (every 2-3 years), depending on the intensity of use. Regular functional and range checks are mandatory (see section 2.6 "Range check" on page 46).

NOTICE

Never use abrasive cleaning agents such as spirit or solvents!

- Remove dust and dirt preferably with a soft bristle brush.
- Remove persistent dirt, in particular grease and oil, with a moist cloth and, if required, with a mild household cleaning agent.
- Protect the transmitter against mechanical impact and shock.
The transmitter should be stored and transported in a suitable container (bag or carrying case).

At regular intervals, check that the transmitter case, mechanical parts and especially the wiring and contacts are in good condition.

10 Appendix**10.1 Specifications**

	PROFI TX 9	PROFI TX 12	PROFI TX 16
Channels	9	12	16
Model memories	50	100	200
Transmission type	M-LINK 2.4GHz spread spectrum + frequency hopping		
Servo pulse width at +/- 100% servo travel	UNI 1.5 ± 0.55ms		
Power supply	3.3V LiFePO4 4000mAh		
Current consumption	approx. 120 mA		
Charging via USB socket	<ul style="list-style-type: none">• 500mA on the PC• Up to 1.5A using a special charger		
Permissible temperatures	<ul style="list-style-type: none">• operation: -15°C to +55°C• storage: -20°C to +60°C• charging: 0°C to +40°C		
Weight with battery	approx. 1800 g		
Dimensions without stick tops	L x H X W: 235 x 250 x 71 mm		

10.2 Accessories

2-position ON/OFF switch, long
Item No.: 75750



2-position ON/OFF switch, long
Item No.: 75751



3-position ON/OFF/ON switch, short
Item No.: 75752



3-position ON/OFF/ON switch, short
Item No.: 75753



COPILOT
Item No.: 45184



Digi-adjuster
Item No.: 75755



Rotary knob
Item No.: 75756



PROFI TX hand-rest
Item No.: 85701



Aluminium stick unit, long, with 2-position switch
Item No.: 85940



Aluminium stick unit, long, with 3-position switch
Item No.: 85941



Aluminium stick unit, long, with push-button
Item No.: 85942



Transmitter case
Item No.: 763323



Lanyard transmitter neckstrap
Item No.: 85710



Standard transmitter neckstrap
Item No.: 85711



Push-button
Item No.: 75754



USB plug-in charger 100-240V
Item No.: 145534



USB car plug-in charger 12V DC
Item No.: 145533

Glossary of technical terms

Allocation

Permanently allocating a set value to a digi-adjuster.

Assignment

Defines which function in the transmitter or model is controlled or switched by which control.

Battery management

Determines the remaining operating time (time to empty), the capacity and other battery data from the current and voltage characteristics. Optimises the charge / discharge limits for a long battery life.

Binding

Required to ensure that the receiver exclusively responds to signals from its specific (bound) transmitter. The binding procedure must be performed during initial setup.

Re-binding is required when switching to the "FastResponse" option. FastResponse reduces the transmission cycle to 14ms and the number of available servo channels is reduced to 12.

Centre trim

Trim corrections do not change the end-travels.

Combi-Switch

Links aileron and rudder in a way that allows both of the control functions to be controlled by either of the functions. This makes it easier to fly accurate turns.

Control

Any transmitter control which can be assigned to a control function or switched function:

- Sticks
- Slide potentiometers
- Rotary potentiometers
- Switches and their designated buttons

Control function

"Aileron", "Elevator", "Throttle", etc. are control functions with a set of configuration options that is specific to their function. A control or fixed value is assigned to them for operation. Any control function is uniquely identified by a 12-digit freely configurable name. The PROFI TX can manage 15 control functions. Control functions are assigned to mixer inputs and servos. Direct control assignment is not intended.

Differential

Indicates the percentage by which the travel distance of the control surface down is reduced; if the differential is set to 50%, the travel distance down is half as great as the travel distance up. The higher the % value, the shorter the travel distance of the control surface down. The prefix of the percentage figure indicates on which side of the wing travel is reduced (depending on control surface linkage and aileron servo sequence).

Why configure a differential?

When flying turns, the outer aileron in the turn moves down, while the inner control surface moves up. The downward control surface generates greater drag than the upward control surface. This results in a negative turning moment (known as adverse yaw) which tends to push the model out of the turn. This problem is solved by a correctly configured differential.

Digital trim

Digital trim buttons do not have any physical position corresponding to the actual trim value (which is the case for conventional trim with trim sliders). The digital trim position is displayed on the screen, and the trim values are stored in the model memory. If you switch model memories, there is no need to return the trim sliders to the correct position to suit the model. The correct trims are immediately available.

If the **PROFI TX** is used with a model for which you have set up multiple flight phases, each flight phase has its own trim memory, i.e. it is simple to trim each flight phase accurately, and independently of the trims in the other phases.

DTC (only helicopters)

Direct Throttle Control

If DTC is switched on, the throttle channel (regardless of whether it acts upon a carburettor or a speed controller) is controlled directly by the transmitter

control assigned to throttle limiter, and is independent of the position of the collective pitch stick.

Dual rate (D/R)

Changes the control sensitivity of a control. If the D/R parameter for a control function (e.g. Aileron) is set to 50% you can use the assigned switch to reduce the control surface travels on the model by half for finer control. The control curve in the graph changes accordingly when you operate the switch assigned to dual rate.

Expo

Generates a non-linear control function.

- For Expo = 0%, the control works in a linear fashion.
- The effect of negative values is that smaller control surface travels are generated around the centre position with the same stick travel, thus providing finer control.
- The effect of positive Expo values is that control surface travels are increased around the centre position.

The end-travels remain unchanged.

Failsafe

If the receiver stops receiving signals, the servos stop at their most recent positions (Hold function). If Failsafe positions were stored in the receiver, the servos return to these positions after 0.75 seconds. This time setting is stored in the receiver. It can be edited using the MULTIPLEX Launcher.

FastResponse

Reduces the transmission cycle from 21ms to 14ms. This reduces the response time for control commands. Only 12 servos can be controlled with FastResponse.

Flight phases

Settings / data sets for a model which can be called up by operating a switch. The data sets are optimised for particular flight tasks.

Lower limit for throttle (only helicopters)

The lower limit for throttle is used to limit the throttle channel preventing I.C. engines from being turned off inadvertently.

MagicSwitch

Logical switch, which can be assigned like a normal control; it combines up to three switches in an AND function. The result can be combined with a 4th switch by OR. Unused AND inputs are considered switched on. The OR input is switched off when not in use. In addition, switching can be delayed.

Mixer

For combining control functions (e.g. elevator, aileron, etc.) in various percentages.

In the **PROFI TX**, 7 freely configurable mixers with 8 inputs each for mixing on the servo side.

Mode

Defines the assignment of the main control functions Aileron, Elevator, and Rudder to the stick units.

Model template

Template for creating new models; thanks to model templates, new models can be created more easily and quickly since the basic configuration is more or less completed by selecting the template. Model templates also contain the basic configuration for mixers, controls, servos and flight phases.

Range check

Is used to check the proper operation of the radio link. The transmitter power is reduced to approx. 1% so that the check can be performed at a shorter distance.

Ratchet

Ratchet system in which a mechanism assumes and holds a specific position.

Servo calibration**Servo curve**

Used to define the maximum control surface travels, set the neutral position, and configure the control surface travels of servos with the same function to the same value. Also for trimming servos on surface pairs to synchronous operation.

Servo reverse

Used to change the rotation direction of a servo.

Snap flap

Elevator mixer to the camber-changing flaps (flaps) and/or the ailerons.

Spoiler

Used for glide path control or for "braking" the model.

Switch

Controls that switch functions on or off or toggle between functions; multiple menus are available for assigning switches to functions. Standard functions (D/R, Timer, etc.) are compiled in a list.

Thr.Limiter (only helicopters)

Restricts (limits) the maximum possible throttle value. This allows safer model setups. For normal flying, the limiter is set to maximum.

After startup of the power system, the throttle limiter can be used to slowly increase the speed of the main rotor.

Throttle curve (only helicopters)

The throttle curve has 7 points and determines how much throttle is assigned to the individual positions of the collective pitch stick. The aim is a constant speed, i.e. the higher the collective pitch, the more the throttle is advanced.

Throttle-Cut

While this switch is switched on, the throttle channel is maintained in the position which you earlier selected during travel adjustment as point P1 for the throttle servo. This enables you to "switch off" an I.C. engine, assuming that the carburettor barrel is fully closed at this position.

Throttle trim (idle)

You can use this function to fine-tune the idle characteristics of an I.C. engine to suit the operating conditions (temperature, humidity). Trimming is carried out using the trim button adjacent to the stick which you have selected (via "Mode") to control throttle and collective pitch.

Trainer mode

Safest method for beginners to get started in model sport; two transmitters are inter-connected using a second M-Link radio link. An experienced modeller has control over the model, and is able to transfer control functions to the student by operating the trainer button ("TEACHER" button). Initially these will be individual control functions, and later all the main control functions are transferred when the "student" has gained sufficient skill. If individual control functions are transferred, the teacher retains control over the remaining control functions. When the TEACHER button is released, the teacher resumes full control of the model—typically if a dangerous situation

develops. The teacher transmitter carries out all the data processing. This means that the student transmitter (depending on the type used) simply needs to be switched to "Student" mode. No further configuration or programming is required. All the teacher transmitter needs from the student transmitter are the pure stick signals.

Trimming

Adjustment of the model aircraft to fly straight and level when you leave the sticks exactly at centre.

Standard trim

Shifts the entire setting range of the stick in parallel up and down (by the trim value). To allow this shift without limiting the control signal, the control signal must be reduced by the maximum trim value possible. Thus, unlike centre trim, the servo travel cannot be fully used.

Variometer

Device in the model aircraft that indicates the climbing and descending rate through audible signals.

Index

A

Assign

controls->control functions · 94, 95, 104, 128, 170, 171, 183, 192, 194, 210

switch · 11, 50, 55, 94, 103, 106, 109, 133, 137, 161, 173, 175, 188, 189, 193, 205, 206, 210

Auto-rotation · 77, 78, 124, 126, 198, 199, 206

B

Battery

alarm · 43, 88, 94, 114

battery management · 7, 8, 11, 40, 43, 215

battery monitor · 209

charge · 15, 29, 30, 40, 41, 43, 89, 178, 212

plug-in charger · 30

remaining operating time · 8, 87, 215

remove · 42

safety instructions · 15

self-discharge · 43

time to empty · 7, 40, 43, 88, 101, 152, 153, 209

under-voltage cut-off · 43

Binding · 11, 24, 30, 45, 47, 48, 49, 94, 97, 99, 100, 101, 181, 183, 215

C

Code lock · 116

Code lock (PIN) · 8, 94, 116

Combi-Switch · 58, 61, 64, 67, 69, 71, 106, 132, 133, 174, 179, 181, 189, 215

Control functions

Aileron · 51, 56, 58, 59, 61, 62, 63, 64, 65, 66, 67, 69, 70, 71, 72, 73, 74, 75, 76, 77, 78, 79, 105, 112, 118, 119, 120, 121, 132, 133, 134, 136, 141, 143, 147, 170, 171, 172, 182, 184, 185, 186, 187, 188, 190, 196, 205, 215, 216, 218

Airbrake · 58, 59, 63, 72

Aux · 57, 73, 74, 80, 81, 82, 83, 85, 118, 119, 127, 172, 173

camber-changing flap · 57

Collective · 74, 75, 76, 77, 78, 79, 125, 126, 131, 139, 143, 170, 173, 190, 192, 193, 196, 198, 199, 200, 204, 205, 217, 219

Elevator · 47, 51, 56, 58, 59, 61, 62, 63, 64, 65, 66, 67, 68, 70, 71, 72, 73, 74, 75, 76, 77, 78, 79, 100, 101, 105, 118, 119, 121, 132, 136, 141, 143, 149, 170, 171, 172, 186, 188, 189, 190, 196, 216, 218

Flap · 57, 61, 63, 64, 65, 66, 70, 71, 72, 82, 83, 118, 127, 128, 136, 170, 172, 188, 189, 218

Gyro · 57, 73, 75, 76, 77, 78, 79, 85, 118, 119, 128, 129, 130, 139, 173, 193, 194, 199, 201, 202

landing flaps · 62, 63, 71, 72

Mixture · 57, 74, 78, 79, 83, 118, 173

Retract.Gear · 57, 73, 118, 119, 127, 149, 151, 157, 162, 170, 172

Rudder · 51, 56, 58, 59, 61, 62, 64, 65, 67, 68, 71, 72, 73, 74, 75, 76, 77, 78, 79, 105, 107, 118, 119, 121, 130, 132, 139, 170, 171, 172, 187, 189, 190, 199, 200, 201, 202, 215

Spoiler · 24, 56, 57, 58, 59, 60, 62, 63, 64, 65, 66, 70, 71, 72, 82, 83, 112, 118, 127, 132, 134, 136, 170, 171, 172, 182, 183, 187, 188, 189, 219

Switch · 73, 74, 78, 79

Thr.Limiter · 74, 119, 131, 173, 193, 194, 203, 204, 217, 219

Throttle · 17, 24, 51, 55, 56, 58, 59, 62, 64, 65, 67, 68, 69, 70, 71, 72, 73, 74, 75, 76, 77, 78, 79, 81, 82, 83, 84, 85, 106, 118, 119, 123, 124, 125, 126, 127, 131, 139, 149, 157, 162, 170, 171, 172, 173, 174, 182, 183, 189, 190, 192, 193, 194, 200, 203, 205, 216, 217, 219

Towing dog · 57, 118, 172

Wheel Brake · 57, 118, 173

Controls

slider · 24, 49, 56, 107, 172, 193, 201, 202, 203

wheel · 8, 11, 24, 48, 87, 93, 98, 100, 101, 105, 108, 109, 111, 135, 146, 148, 149, 150, 151, 153, 155, 156, 158, 159, 161, 162, 164, 165, 166, 167, 171, 175, 182, 185, 186, 187, 195, 197, 204, 206, 208

Curve

collective pitch · 125, 131, 200, 204, 205

mixer · 113

servo · 146, 218

throttle · 124, 125, 126, 127, 205, 219

D

Digi-adjuster
allocate · 197, 215
allocation button · 147, 148, 165, 168, 169
erasing the allocation · 169

L

Language pair · 116
Language selection · 44, 45

M

Menu direction · 115
Menu language · 44, 45, 116
Mixer · 7, 8, 9, 10, 58, 59, 61, 64, 67, 69, 70, 71, 77, 78, 79,
80, 81, 82, 83, 84, 85, 89, 94, 95, 110, 111, 118, 130,
132, 134, 136, 137, 138, 139, 143, 144, 147, 149, 151,
164, 165, 179, 181, 182, 184, 187, 188, 189, 199, 216,
218
bilateral travel setting · 111
curve · 113
deadband · 112
input · 111
offset · 112
switch · 111
symmetrical travel setting · 111
toggle · 112
travel using 3 points · 112
Model templates
ACRO · 55, 56, 57, 61, 208
BASIC · 55, 56, 57, 58, 59, 179, 181
BIG SCALE · 55, 56, 57, 71
DELTA WING · 55, 56, 57, 67, 147
eHeli FBL · 76
FLYING WING · 55, 69
FUNCOPTER · 55, 73, 75, 204
GLIDER · 55, 56, 57, 64, 128, 136, 183
helicopter with electr. main rotor mixer · 55, 73, 78,
124, 138, 143, 191, 192, 199
helicopter with mech. main rotor mixer · 55, 73, 79,
124, 138, 199
ships & boats · 55, 82
tanks & tracked vehicles · 55, 84

vehicles · 55, 80

P

PIN · 8, 94, 116

R

Range · 19, 45, 47
Reach of children · 15

S

Safety instructions · 7, 11, 12, 13, 15
SD card · 45, 53, 114, 156, 158, 176
Servo
assignment · 58, 61, 64, 67, 69, 71, 75, 76, 77, 78, 79,
81, 83, 85, 140, 190, 194
calibration · 8, 143, 147, 149, 218
Speech output & sounds
announcements
altitude · 210
flight phases · 209
sensors · 209
teacher / student · 101, 211
trim · 209
volume · 9, 10, 94, 95, 209, 210

T

Timer · 8, 9, 10, 38, 55, 91, 106, 152, 153, 154, 155, 164,
170, 174, 219
alarm clock · 9, 152, 155, 156
date · 35, 38, 152, 155, 156
frame · 8, 10, 55, 152, 153, 154, 174
sum · 8, 10, 55, 152, 153, 154, 203
time · 10, 44, 45, 53, 96, 98, 99, 108, 125, 127, 131, 151,
152, 153, 154, 155, 156, 157, 208
transmitter operating time · 8
Transmitter
annular light · 23, 24, 30, 41, 44, 45, 46, 48, 49, 178
carry bars · 26, 27
carry handle · 27

close case · 32
contrast · 8, 23, 94, 114, 115
digi-adjuster · 11, 24, 36, 38, 88, 91, 92, 120, 125, 128,
147, 165, 168, 169, 184, 213, 215
install controls · 24, 30, 36, 50, 168
install stick button/switch · 172
installation slots · 24, 172
modules · 16, 28, 39, 50
open case · 26, 30, 31
rotary potentiometer · 10, 36, 170, 172, 215
screen · 7, 8, 23, 31, 41, 42, 43, 44, 45, 50, 51, 52, 120,
136, 155, 158, 162, 164, 177, 178, 216
simulator mode · 176, 179, 180, 181
software · 8, 9, 11, 87, 109, 116, 170, 173, 176, 177, 178
stick
adjust centring force · 30, 34
adjust friction · 30, 34
adjust ratchet · 30, 34, 218
swivel · 24, 30, 33
switch off · 30, 45, 96, 116, 135, 155, 174, 203
switch on · 30, 43, 44, 45, 48, 49, 53, 87, 95, 101, 114,
116, 157, 163, 169, 174, 178, 209, 210
update · 9, 54, 116, 177, 178
USB · 26, 29, 31, 32, 36, 39, 40, 41, 42, 53, 176, 177,
178, 179, 180, 181, 212, 214
warning lights · 23, 25
Trim
centre trim · 51, 123, 215, 220
trim buttons · 50, 51, 216
trim graph · 52, 115

