

ENDURO

DRIVE TRAIN

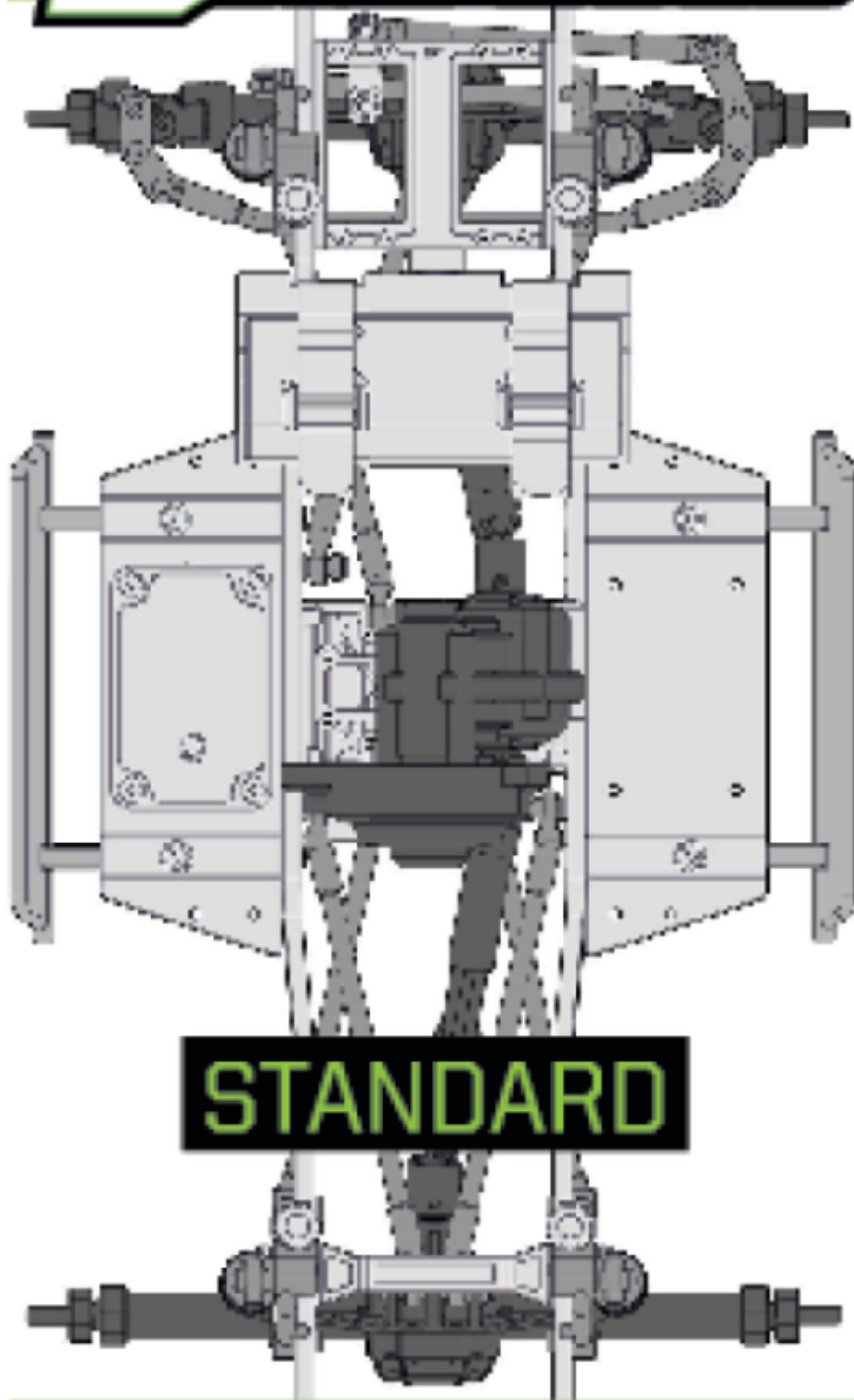

STANDARD

The Enduro drivetrain is designed to suit a variety of applications. The transmission can be rotated to allow for a more forward bias weight distribution, different motor rotational directions, and possible dig unit installations.

The Enduro's axle internals can also be installed flipped for added versatility and build applications.

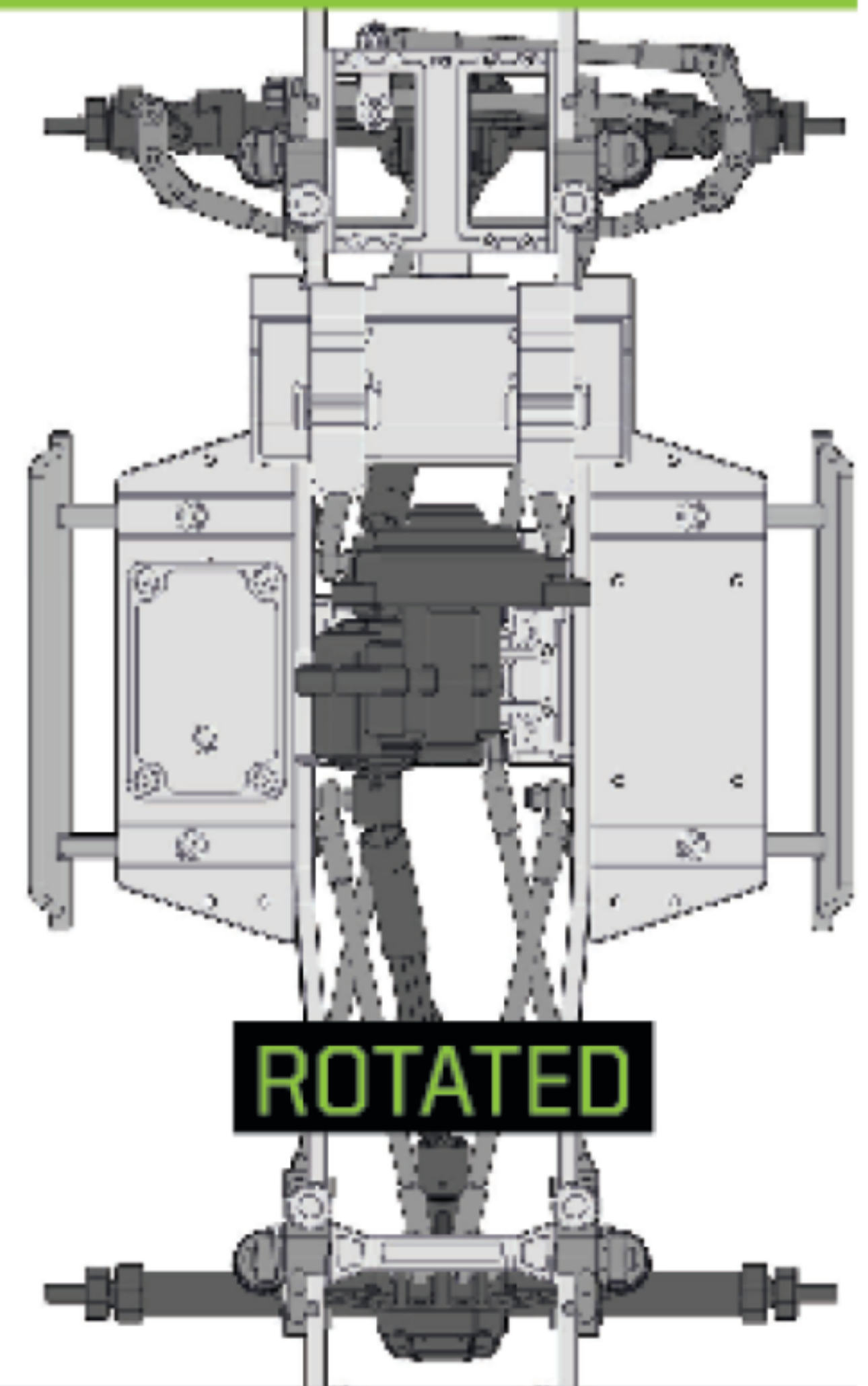

ROTATED

STEALTH® X GEARBOX

STEALTH® X GEARBOX WITH ADJUSTABLE OVERDRIVE GEARS:

At the heart of the Enduro is our revolutionary Stealth® X gearbox. Although the exterior appears to have a conventional 3-gear transmission look, the inside is far from conventional. The Stealth® X features the ability to adjust the rear drive ratio independently from the front drive in 3 levels. Stock overdrives the front end 5.7%, option 1 provides a one-to-one drive ratio front to rear and option 2 overdrives the front end 11.83%.

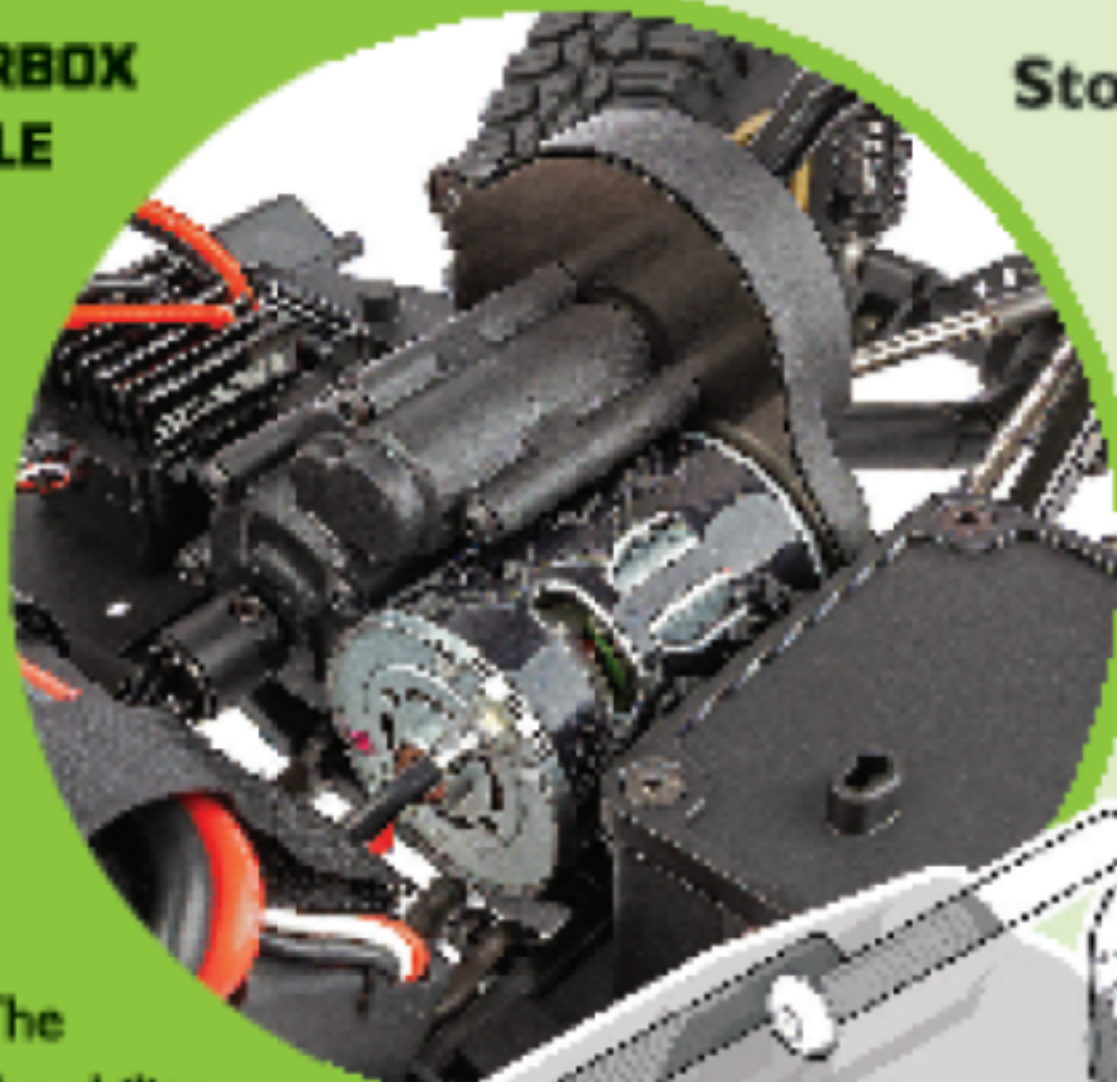

Stock 5.7% Overdrive

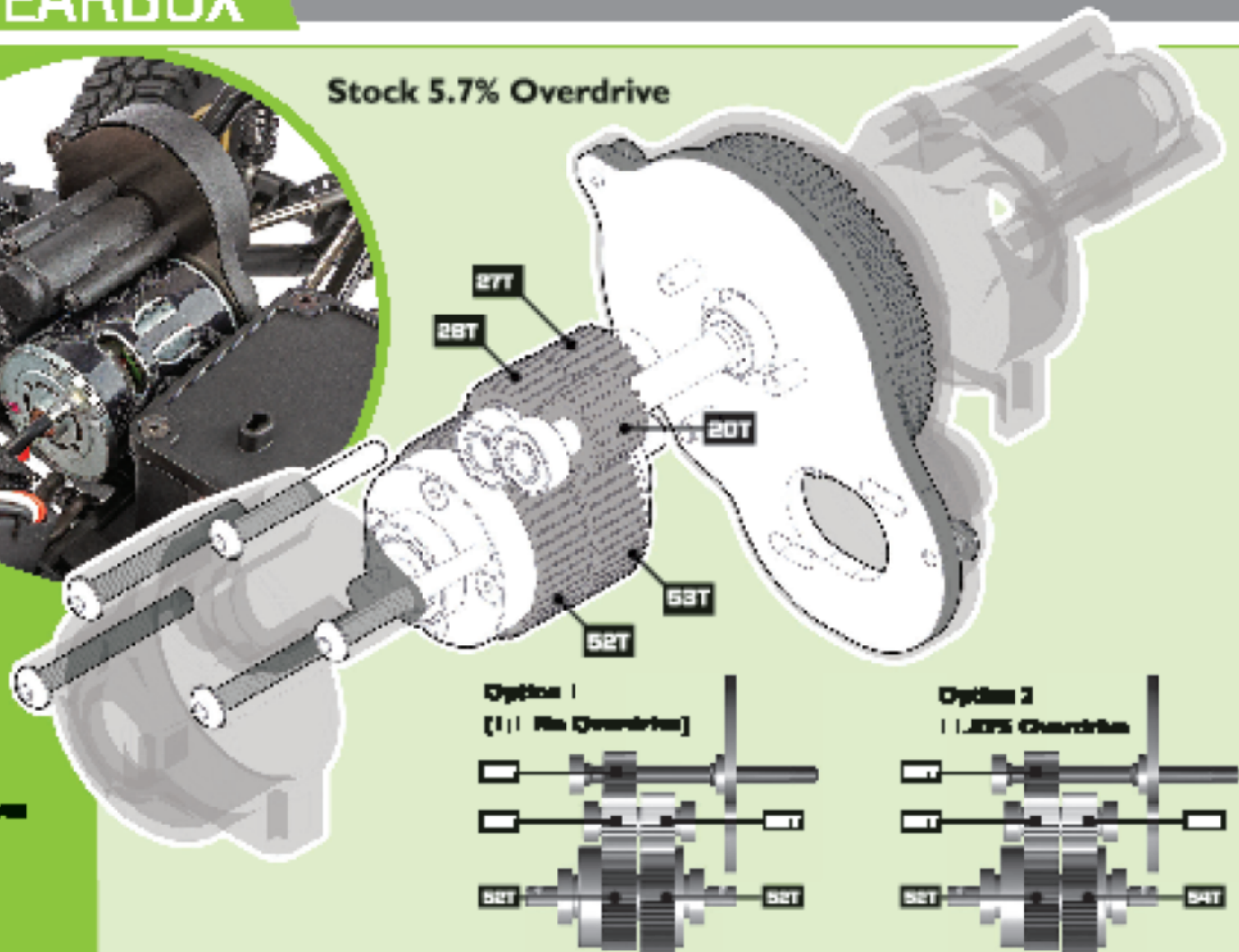

YOUR JOURNEY BEGINS HERE!

