

**STANDARD**

The Enduro drivetrain is designed to suit a variety of applications. The transmission can be rotated to allow for a more forward bias weight distribution, different motor rotational directions, and possible dig unit installations.

The Enduro's axle internals can also be installed flipped for added versatility and build applications.

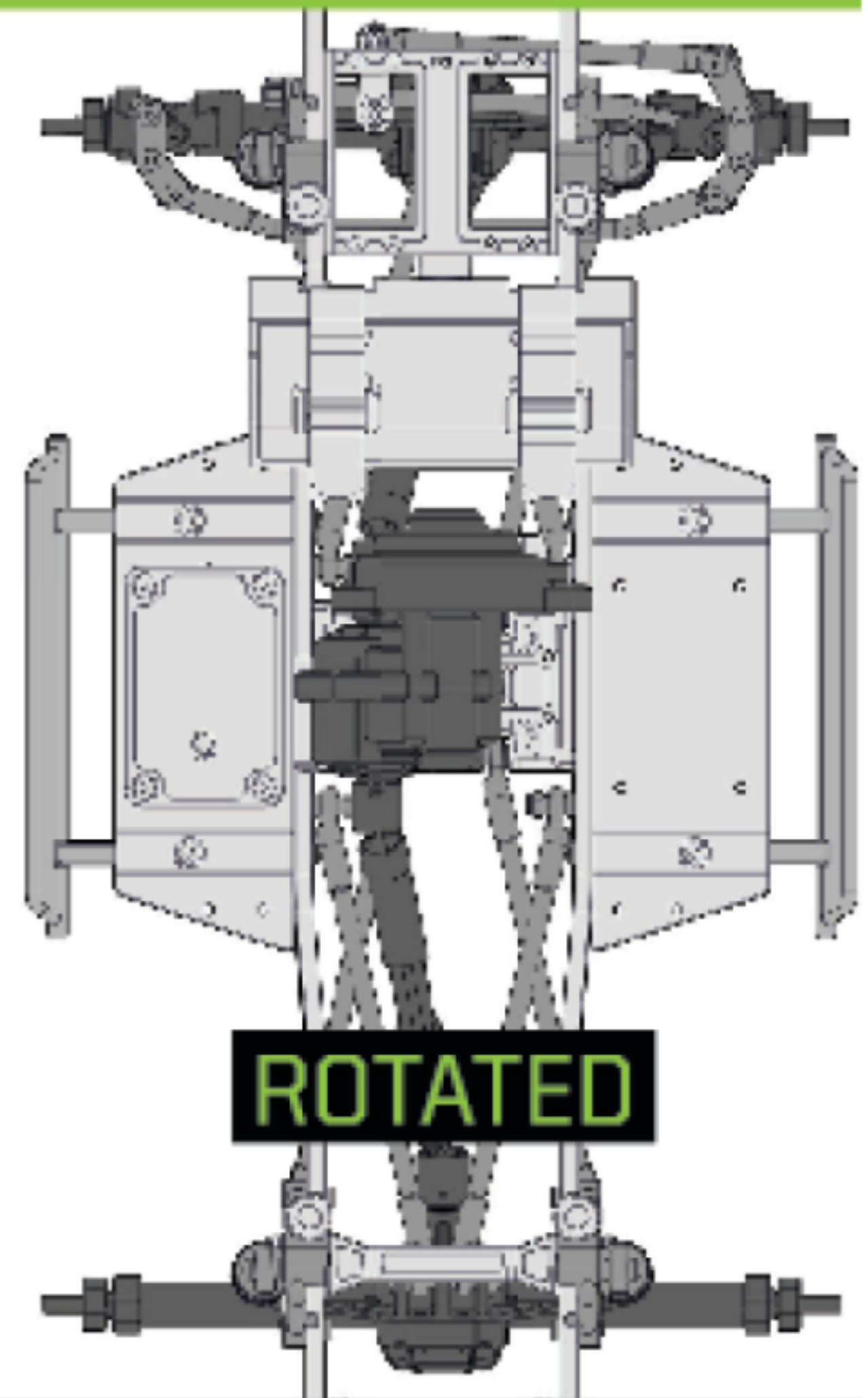

**ROTATED**

## STEALTH® X GEARBOX

### STEALTH® X GEARBOX WITH ADJUSTABLE OVERDRIVE GEARS:

At the heart of the Enduro is our revolutionary Stealth® X gearbox. Although the exterior appears to have a conventional 3-gear transmission look, the inside is far from conventional. The Stealth® X features the ability to adjust the rear drive ratio independently from the front drive in 3 levels. Stock overdrives the front end 5.7%, option 1 provides a one-to-one drive ratio front to rear and option 2 overdrives the front end 11.83%.

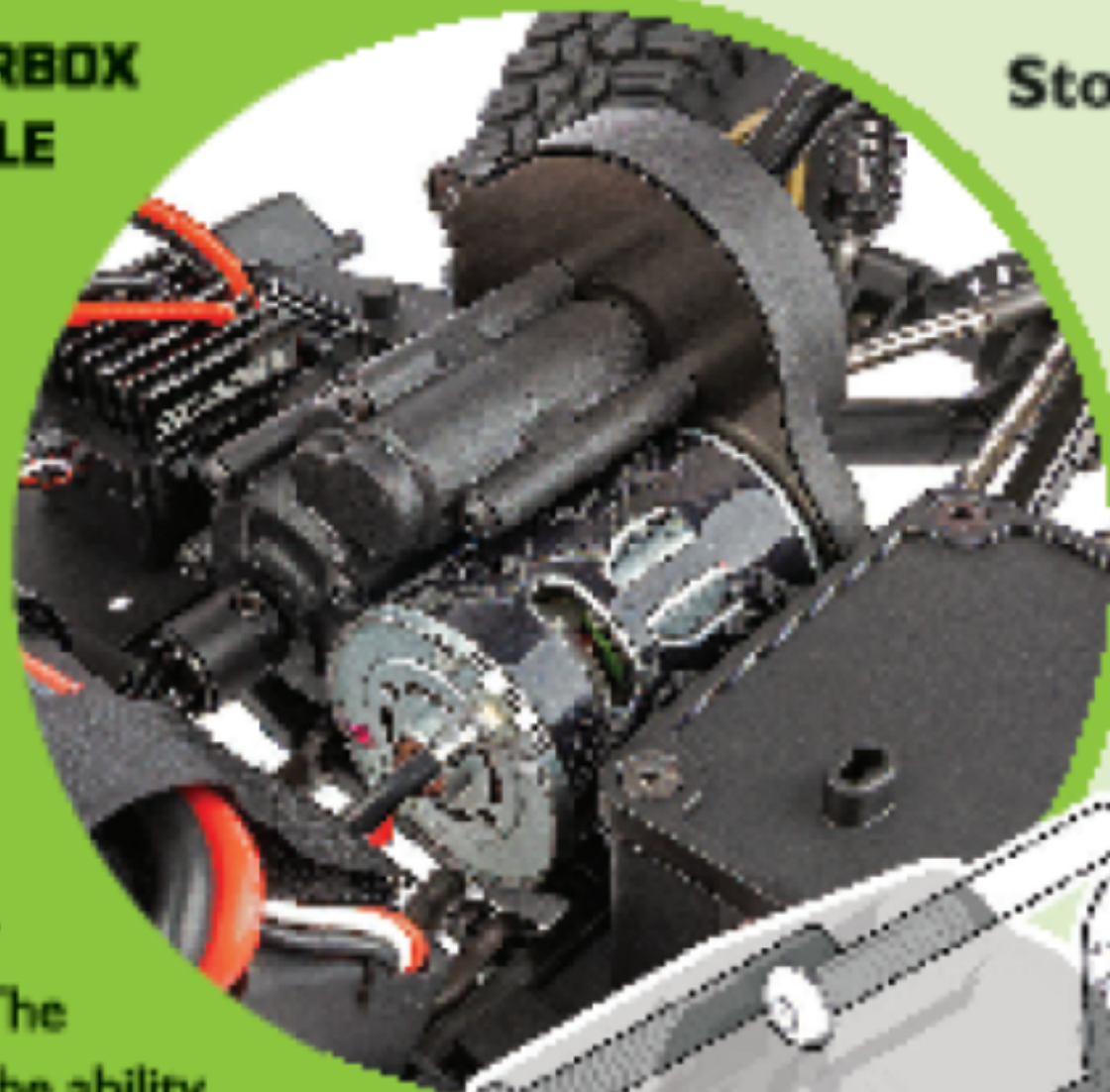

### Stock 5.7% Overdrive

