

Super Combo

ALIGN

# TREX 800E F3C INSTRUCTION MANUAL

## 使用說明書

RH80E09XT



### Contents

1	INTRODUCTION 前言
1~2	SAFETY NOTES 安全注意事項
3	EQUIPMENT REQUIRED FOR ASSEMBLY 自備設備
3	PACKAGE ILLUSTRATION 包裝說明
4	MODEL STANDARD EQUIPMENT DIFFERENCE 標準配備版本說明
5	SAFETY CHECK BEFORE FLYING 飛行前安全檢查重要事項
6~18	ASSEMBLY SECTION 組裝說明
18	EQUIPMENT INSTALLATION 各項設備配置圖
20	BATTERY INSTALLATION ILLUSTRATION 電池安裝示意圖
21	INSTALLATION FOR ESC 無刷調速器安裝
21	CANOPY ASSEMBLY 機頭罩安裝
22	ELECTRIC EQUIPMENT ILLUSTRATION 電子設備建議配置圖示
22~23	MICROBEAST PLUS FLYBARLESS MANUAL 無平衡翼系統使用說明
24	SERVO SETTING AND ADJUSTMENT 伺服器設定調整
24	ADJUSTMENTS FOR GYRO AND TAIL NEUTRAL SETTING 陀螺儀與尾翼中立點設定調整
25	PITCH AND THROTTLE SETTING 主旋翼螺距與油門設定
26	POWER COLLOCATION REFERENCE 原裝動力數據參考表
27~28	FLIGHT ADJUSTMENT AND SETTING 飛行動作調整與設定
30	TROUBLESHOOTING 飛行中狀況排除



BEASTX™

MICROBEAST PLUS

6-AXIS MEMS SENSOR SYSTEM FOR RC-MODELS

Thank you for purchasing Align products. Please read the manual carefully before installing and be sure to retain the manual for future reference. All pictures shown are for illustration purpose only. Actual product may vary due to product enhancement. Specifications, contents of parts and availability are subject to change, ALIGN RC is not responsible for inadvertent errors in this publications.

承蒙閣下選用亞拓遙控世界系列產品，謹表謝意。使用前，請務必詳閱本說明書，相信一定能夠給您帶來相當大的幫助，也請您妥善保管這本說明書，以做為日後參考。本公司將不對此印刷物之異動負責，也無法主動通知消費者任何更新或異動。所有圖片僅用於展示目的。產品可能因改良而有些不同。本說明書內記載的材質、規格或零件包裝之內容物如有異動，請依亞拓官網公告為主。

Thank you for buying Align products. The T-REX 800E F3C helicopter is special edition for extreme 3D flight, as same as other T-REX sibling, full featured Helicopter R/C model capable of all forms of rotary flight. Please read the manual carefully before assembling the model, and follow all precautions and recommendations located within the manual. Be sure to retain the manual for future reference, routine maintenance, and tuning. The T-REX 800E F3C is a new product developed by ALIGN. It features the best design available on the Micro-Heli market to date, providing flying stability for beginners, full aerobatic capability for advanced fliers, and unsurpassed reliability for customer support.

感謝您選購亞拓產品，為了讓您容易方便的使用 T-REX 800E F3C 直昇機，請您詳細的閱讀完這本說明書之後再進行組裝以及操作這台直昇機，同時請您妥善的保存這本說明書，作為日後進行調整以及維修的參考。T-REX 800E F3C 是由亞拓自行研發的新產品，不論是需求飛行穩定性的初學者或是追求性能的飛行愛好者，T-REX 800E F3C 將是您最佳的選擇。

### WARNING LABEL LEGEND 標誌代表涵義

 FORBIDDEN 禁止	<b>Do not attempt under any circumstances.</b> 在任何禁止的環境下，請勿嘗試操作。
 WARNING 警告	<b>Mishandling due to failure to follow these instructions may result in damage or injury.</b> 因為疏忽這些操作說明，而使用錯誤可能造成財產損失或嚴重傷害。
 CAUTION 注意	<b>Mishandling due to failure to follow these instructions may result in danger.</b> 因為疏忽這些操作說明，而使用錯誤可能造成危險。

### IMPORTANT NOTES 重要聲明

R/C helicopters, including the T-REX 800E F3C are not toys. R/C helicopter utilize various high-tech products and technologies to provide superior performance. Improper use of this product can result in serious injury or even death. Please read this manual carefully before using and make sure to be conscious of your own personal safety and the safety of others and your environment when operating all ALIGN products. Manufacturer and seller assume no liability for the operation or the use of this product. This product is intended for use only by adults with experience flying remote control helicopters at a legal flying field. After the sale of this product we cannot maintain any control over its operation or usage.

As the user of this product, you are solely responsible for operating it in a manner that does not endanger yourself and others or result in damage to the product or the property of others.

T-REX 800E F3C 遙控直昇機並非玩具，它是結合了許多高科技產品所設計出來的休閒用品，所以商品的使用不當或不熟悉都可能會造成嚴重傷害甚至死亡，使用之前請務必詳讀本說明書，勿輕忽並注意自身安全。注意！任何遙控直昇機的使用，製造商和經銷商是無法對使用者於零件使用的損耗異常或組裝不當所發生之意外負任何責任，本產品是提供給有操作過模型直昇機經驗的成人或有相當技術的人員在旁指導於當地合法遙控飛行場飛行，以確保安全無虞下操作使用，產品售出後本公司將不負任何操作和使用控制上的任何性能與安全責任。

做為本產品的使用者，您，是唯一對於您自己操作的環境及行為負全部的責任之人。

We recommend that you obtain the assistance of an experienced pilot before attempting to fly our products for the first time. A local expert is the best way to properly assemble, setup, and fly your model for the first time. The T-REX 800E F3C requires a certain degree of skill to operate, and is a consumer item. Any damage or dissatisfaction as a result of accidents or modifications are not covered by any warranty and cannot be returned for repair or replacement. Please contact our distributors for free technical consultation and parts at discounted rates when you experience problems during operation or maintenance. As Align Corporation Limited has no control over use, setup, final assembly, modification or misuse, no liability shall be assumed nor accepted for any resulting damage or injury. By the act of use, setup or assembly, the user accepts all resulting liability.

模型商品屬於高操作技術且為消耗性之商品，如經拆裝使用後，會造成不等情況零件損耗，任何使用情況所造成商品不良或不滿意，將無法於保固條件內更換新品或退貨，如遇有使用操作維修問題，本公司全省分公司或代理商將提供技術指導、特價零件供應服務。對使用者的不當使用、設定、組裝、修改、或操作不良所造成的破損或傷害，本公司無法控制及負責。任何使用、設定、組裝、修改、或操作不良所造成的破損、意外或傷害，使用者應承擔全部責任。

### 2. SAFETY NOTES 安全注意事項

 CAUTION 注意	<ul style="list-style-type: none"> <li>· Fly only in safe areas, away from other people. Do not operate R/C aircraft within the vicinity of homes or crowds of people. R/C aircraft are prone to accidents, failures, and crashes due to a variety of reasons including, lack of maintenance, pilot error, and radio interference. Pilots are responsible for their actions and damage or injury occurring during the operation or as a result of R/C aircraft models.</li> <li>· Prior to every flight, carefully check rotorhead spindle shaft screws and tail blade grip screws, linkage balls and screws, ensure they are firmly secured.</li> <li>· 遙控模型飛機、直昇機屬高危險性商品，飛行時務必遠離人群，人為組裝不當或機件損壞、電子控制設備不良，以及操控上的不熟悉，都有可能導致飛行失控損傷等不可預期的意外，請飛行者務必注意飛行安全，並需了解自負疏忽所造成任何意外之責任。</li> <li>· 每趟飛行前須仔細檢查，主旋翼夾座橫軸螺絲、尾旋翼夾座螺絲，以及機身各部位球頭、螺絲，確實上膠鎖緊才能升空飛行。</li> </ul>
--	---



## LOCATE AN APPROPRIATE LOCATION 遠離障礙物及人群

R/C helicopters fly at high speed, thus posing a certain degree of potential danger. Choose a legal flying field consisting of flat, smooth ground without obstacles. Do not fly near buildings, high voltage cables, or trees to ensure the safety of yourself, others and your model. For the first practice, please choose a legal flying field. Do not fly your model in inclement weather, such as rain, wind, snow or darkness.

直昇機飛行時具有一定的速度，相對的也潛在著危險性，場地的選擇也相對的重要，請遵守當地法規到合法遙控飛行場地飛行。務必選擇在空曠合法專屬飛行場地，並必須注意周邊有沒有人、高樓、建築物、高壓電線、樹木等等，避免操控的不當造成自己與他人財產的損壞。請勿在下雨、打雷等惡劣天氣下操作，以確保本身及機體的安全。



## NOTE ON LITHIUM POLYMER BATTERIES 鋰聚電池注意事項

Lithium Polymer batteries are significantly more volatile than alkaline or Ni-Cd/Ni-MH batteries used in RC applications. All manufacturer's instructions and warnings must be followed closely. Mishandling of Li-Po batteries can result in fire. Always follow the manufacturer's instructions when disposing of Lithium Polymer batteries.

鋰聚電池跟一般在RC使用的鹼性電池、鎳鎘電池、鎳氫電池比較起來是相對危險的。請嚴格遵守鋰聚電池說明書之使用注意事項。不恰當使用鋰聚電池，可能造成火災並傷及生命財產安全，切勿大意！

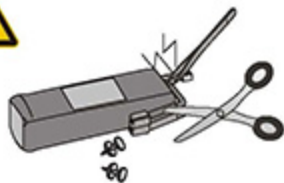

## PREVENT MOISTURE 遠離潮濕環境

R/C models are composed of many precision electrical components. It is critical to keep the model and associated equipment away from moisture and other contaminants. The introduction or exposure to water or moisture in any form can cause the model to malfunction resulting in loss of use, or a crash. Do not operate or expose to rain or moisture.

直昇機內部也是由許多精密的電子零組件組成，所以必須絕對的防止潮濕或水氣，避免在浴室或雨天時使用，防止水氣進入機身內部而導致機件及電子零件故障而引發不可預期的意外！

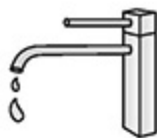

## PROPER OPERATION 勿不當使用本產品

Please use the replacement of parts on the manual to ensure the safety of instructors. This product is for R/C model, so do not use for other purpose.

請勿自行改造加工，任何的升級改裝或維修，請使用亞拓產品目錄中的零件，以確保結構的安全。請確認於產品限內操作，請勿過載使用，並勿用於安全、法令外其它非法用途。



## OBTAIN THE ASSISTANCE OF AN EXPERIENCED PILOT 避免獨自操控

Before turning on your model and transmitter, check to make sure no one else is operating on the same frequency. Frequency interference can cause your model, or other models to crash. The guidance provided by an experienced pilot will be invaluable for the assembly, tuning, trimming, and actual first flight or unforeseen danger may happen. (Recommend you to practice with computer-based flight simulator.)

至飛行場飛行前，需確認是否有相同頻率的同好正進行飛行，因為開啓相同頻率的發射器將導致自己與他人立即墜毀等意外危險。遙控飛機操控技巧在學習初期有著一定的難度，要盡量避免獨自操作飛行，需有經驗的人士在旁指導，才可以操控飛行，否則將可能造成不可預期的意外發生。(動線電腦模擬器及老手指導是入門必要的選擇)



## SAFE OPERATION 安全操作

Make sure to always be aware to keep your eyes and body away from blades rotation. Do not attempt to grab or make contact with the helicopter while the main blades are in motion. During take-off, landing, and flight, be sure to keep the helicopter away from all obstacles. Operators must stand at least 10 meters away from the helicopter. Never take your eyes off the model or leave it unattended while it is turned on, and immediately turn off the model and transmitter when you have landed the model. Operate this unit within your ability, do not fly under tired condition, improper operation may cause in danger, and always to avoid injury caused by loose parts due to improper assembly or any unforeseen dangers.

請隨時注意，無論在任何時候，都不能將旋轉中的旋翼對準眼睛，嚴禁用手抓取運行中的直昇機，當主旋翼轉動後，或起飛/試飛時，務必遠離障礙物，站立位置必需距離10公尺以上，不可在視線範圍外進行飛行，降落後也請馬上關掉直昇機和遙控器電源。操作這台直昇機需要一定操控技術及能力，避免因人為組裝不當造成零件脫落，而引發不可預期的財物及人員損傷，並請衡量自身情況，過於疲勞、精神不佳或不當操作，都可能引誘不可預期的意外發生。



## ALWAYS BE AWARE OF THE ROTATING BLADES 遠離旋轉中零件

During the operation of the helicopter, the main rotor and tail rotor will be spinning at a high rate of speed. The blades are capable of inflicting serious bodily injury and damage to the environment. Be conscious of your actions, and careful to keep your face, eyes, hands, and loose clothing away from the blades. Always fly the model a safe distance from yourself and others, as well as surrounding objects.

直昇機主旋翼與尾旋翼旋轉時會以高轉速下進行，在高轉速下的旋翼會造成自己與他人在身體上或環境上的嚴重損傷，請勿觸摸旋轉中的主旋翼與尾旋翼，並保持安全距離以避免造成危險及損壞。









## KEEP AWAY FROM HEAT 遠離熱源

R/C models are made of various forms of plastic. Plastic is very susceptible to damage or deformation due to extreme heat and cold climate. Make sure not to store the model near any source of heat such as an oven, or heater. It is best to store the model indoors, in a climate-controlled, room temperature environment.



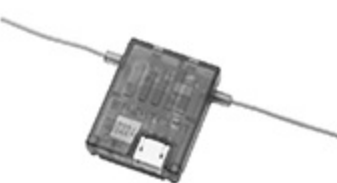







遙控飛機多半是以 PA 纖維或聚乙烯、電子商品為主要材質，因此要盡量遠離熱源、日曬，以避免因高溫而變形甚至熔毀損壞的可能。



#### RADIO TRANSMITTER AND ELECTRONIC EQUIPMENT REQUIRED FOR ASSEMBLY 自備遙控及電子設備

 <b>Transmitter</b> (6-channel or more, Helicopter system) 發射器 (六動以上直升機模式遙控器)	 <b>Receiver(6-channel or more)</b> 接收器 (六動以上)	 or <b>Remote Receiver</b> 衛星天線
 <b>RCC-300 Intelligent Battery Charger</b> RCC-300 智慧型充電器	 <b>22.2V 6S 4500-5200mAh Li-Po Battery x 2 pcs</b> 22.2V 6S 4500-5200mAh Li-Po 電池 x 2	 <b>Receiver Battery</b> 7.4V 2S 1900-2300mAh Li-Po x 1pcs 接收器電池 7.4V 2S 1900-2300mAh Li-Po x 1

#### ADDITIONAL TOOLS REQUIRED FOR ASSEMBLY 自備工具

 <b>[H70118]</b> Swashplate Leveler 十字盤校正器	 <b>[HET80001]</b> AP800 Digital Pitch Gauge AP800 數位標距規	 <b>[HETMT901]</b> Multi-function Tester 多功能檢測計				
 <b>Phillips Screw Driver</b> 十字螺絲起子 φ 3.0/ φ 1.8mm	 <b>Cutter Knife</b> 刀子	 <b>Hexagon Screw Driver</b> 六角螺絲起子 3mm/2.5mm/ 2mm/1.5mm	 <b>Needle Nose Pliers</b> 尖嘴鉗	 <b>Oil</b> 潤滑油	 <b>CA Glue</b> 瞬間膠	 <b>Grease</b> 潤滑油

### 4.PACKAGE ILLUSTRATION 包裝說明

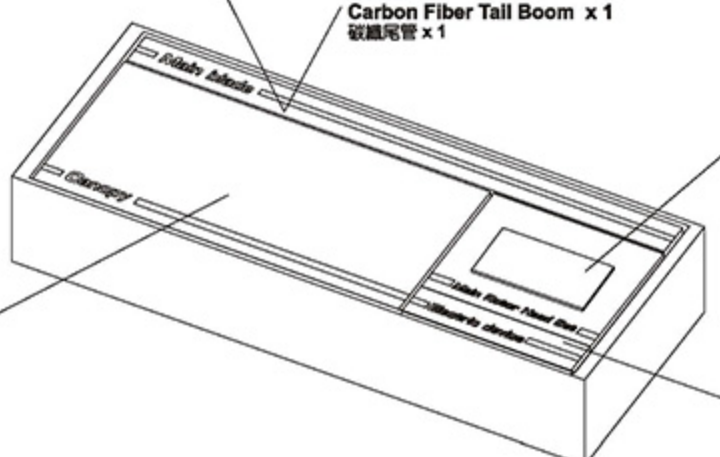

780 Carbon Fiber Blades x 1set  
780 碳纖維主旋翼 x 1組

800HT5 Carbon Fiber Tail Boom x 1  
碳纖維尾管 x 1

Canopy  
機頭罩

**Quick Finder**  
零件快速購



Microbeast PLUS Flybarless System x 1  
無平旋翼系統 x 1

RCM-BL850MX (490KV/4535) Motor x 1  
RCM-BL850MX(490KV/4535) 無刷馬達 x 1

BL815H High Voltage Brushless Servo x 3  
BL815H 高電壓無刷伺服器 x 3

BL855H High Voltage Brushless Servo x 1  
BL855H 高電壓無刷伺服器 x 1

Castle Edge HV 160 ESC x 1  
Castle Edge HV160 無刷调速器 x 1



















Servo Extension Cable x 2  
伺服器延長線 x 2

There are many versions of T-REX 800E F3C for your choice. The Super Combo includes additional electronics and other equipment. The Instruction Manual will refer to the T-REX 800E F3C Super Combo. You may purchase any additional items referenced in the instruction manual or any spare parts for other 800E F3C version by referring to more product information in this manual.

T-REX 800E F3C系列商品有多種版本可作為選擇，除標準配備會因您購買的商品版本而有些微不同，在組裝、設定上都是一致的，在此我們以 Super Combo作為操作範例，您也可依照書面上的商品資訊來增添其他選購商品。



T-REX 800E F3C SUPER COMBO STANDARD EQUIPMENT T-REX 800E F3C SUPER COMBO 標準配備 [RH80E09XT]

					
800HC3	800FLH6	700HB1	800HB9	700HB10	700HB14
					
Repair Towel x 1 維修桌巾 X 1	800HT1	800HT8	800HT5 Carbon Fiber Tail Boom x 1 碳纖維尾管 X 1	700HG2	800FLH4 780 Carbon Fiber Blades x 1set 780 碳纖維主旋翼 x 1組
					
850MX Brushless Motor (490KV/4535) x 1 850MX 無刷馬達 (490KV/4535) x 1	M4x4 Set Screw x 2 M4x4 止洩螺絲 x 2 Motor Slant Thread Pinion Gear 12T x 1 馬達斜齒輪 12T x 1	Microbeast PLUS Flybarless System x 1 無平衡系統 x 1	BL815H High Voltage Brushless Servo x 3 BL815H 高電壓無刷伺服器 x3	BL855H High Voltage Brushless Servo x 1 BL855H 高電壓無刷伺服器 x1	Castle Edge HV 160 ESC x 1 Castle Edge HV 160 無刷調速器 x 1

## CAREFULLY INSPECT BEFORE REAL FLIGHT 請嚴格執行飛行前之檢查義務

- Before flying, please check to make sure no one else is operating on the same frequency for the safety.
- Before flight, please check if the batteries of transmitter and receiver are enough for the flight.
- Before turn on the transmitter, please check if the throttle stick is in the lowest position. IDLE switch is OFF.
- When turn off the unit, please follow the power on/off procedure. Power ON- Please turn on the transmitter first, and then turn on receiver. Power OFF- Please turn off the receiver first and then turn off the transmitter. Improper procedure may cause out of control, so please to have this correct habit.
- Before operation, check every movement is smooth and directions are correct. Carefully inspect servos for interference and broken gear.
- Check for missing or loose screws and nuts. See if there is any cracked and incomplete assembly of parts. Carefully check main rotor blades and rotor holders. Broken and premature failures of parts possibly cause a dangerous situation.
- Check all ball links to avoid excess play and replace as needed. Failure to do so will result in poor flight stability.
- Check if the battery and power plug are fastened. Vibration and violent flight may cause the plug loose and result in out of control.
- 每次飛行前應先確認所使用的頻率是否會干擾他人，以確保您自身與他人的安全。
- 每次飛行前確定您發射器與接收器電池的電量是在足夠飛行的狀態。
- 開機前確認油門搖桿是否位於最低點，熄火降落開關，定速開關(IDLE)是否於關閉位置。
- 開機時必須遵守電源開關機的程序，開機時應先開啟發射器後，再開啟接收器電源；關機時應先關閉接收器後，再關閉發射器電源。不正確的開關程序可能會造成失控的現象，影響自身與他人的安全，請養成正確的習慣。
- 開機請先確定直昇機的各個動作是否順暢，及方向是否正確，並檢查伺服器的動作是否有干涉或崩齒的情形，使用故障的伺服器將導致不可預期的危險。
- 飛行前確認沒有缺少或鬆脫的螺絲與螺帽，確認沒有組裝不完整或損毀的零件，仔細檢查主旋翼是否有損壞，特別是接近主旋翼夾座的部位。損壞或組裝不完整的零件不僅影響飛行，更會造成不可預期的危險。注意：每次飛行前的安全檢查、保養、及更換損耗零件，請確實嚴格執行以確保安全。
- 檢查所有的連桿頭是否有鬆脫的情形，過鬆的連桿頭應先更新，否則將造成直昇機無法操控的危險。
- 確認電池及電源接頭是否固定牢靠，飛行中的震動或激烈的飛行，可能造成電源接頭鬆脫而造成失控的危險。

When you see the marks as below, please use relative glue or grease to ensure flying safety.

標有以下符號之組裝步驟，請配合上膠或上油，以確保鎖附零件使用之可靠度。

• CA : Apply small amount of CA Glue to fix.

瞬間膠：使用適量瞬間膠固定

• OIL : Add small amount of OIL.

潤滑油：添加適量潤滑油

• R48 : Apply small amount of Anaerobic Retainer to fix.

缺氣膠：使用適量缺氣膠固定

• Grease : Add small amount of Grease.

潤滑油：添加適量潤滑油

• T43 : Apply small amount of Thread Lock to fix.

螺絲膠：使用適量螺絲膠

When assembling ball links, make sure the "A" character faces outside.

各項塑膠製連桿頭扣接時，"A"字請朝外。



Keep plastic parts away from heat.  
塑膠件避免接近熱源。



CA Glue  
瞬間膠



R48  
Anaerobic Retainer  
缺氣膠



T43  
Thread Lock  
螺絲膠



Grease  
潤滑油



Oil  
潤滑油

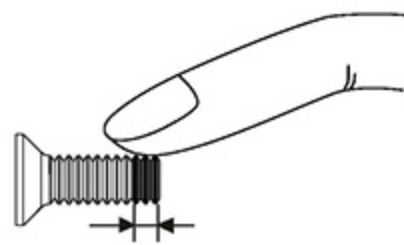

T43 Glue width : approx. 1mm  
T43上膠寬度約1mm

1. Anaerobic Retainer (R48) is green penetrating threadlocker and is used to fix the metal tube before assembly at temperatures up to +180°C.
2. Thread Lock (T43) is blue low strength threadlocker and is applied to the small screw (threads) or metal parts before assembly to prevent loosening. Ensure to apply only a small amount and wipe surplus off. When disassembling, recommend to heat the metal joint about 15 Seconds.
3. Grease is kind of lubricant additive which is applied to the one-way bearings or thrust bearing.

Based on parts physical attributes, please apply small amount of the relative glue or grease accordingly to prevent any parts damage or loosening or unexpected danger happened.

1. 缺氣膠 (R48) 為綠色高強度快速固化的缺氣膠，適合於金屬管狀固定用，可耐高溫至 180 °C。
2. 螺絲膠 (T43) 為藍色低強度螺絲膠，適合小型螺絲；使用於金屬內外徑或膠合螺絲時，請務必適量使用，必要時請用手去除多餘膠量，欲拆卸時可於金屬接合部位熱烤約 15 秒。
3. 潤滑油 (Grease) 為膏狀潤滑油，適用於單向軸承或止推軸承。

上述各類功能膠(油)請依零件屬性需求自行準備並斟酌其用量，以達到最佳組裝狀態，避免因使用不當造成零件損壞或不可預期的意外發生。

## 800FLH6

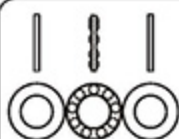

**Thrust Bearing**  
止推軸承 (φ 10.2x φ 18x5.5mm) x 2



**Bearing**  
軸承 (φ 10x φ 19x5mm) x 4



**Spindle Bearing Spacer**  
橫軸止推華司 (φ 10x φ 16x1mm) x 2



**Socket Collar Screw**  
圓頭內六角軸套螺絲 (M3x6mm) x 4

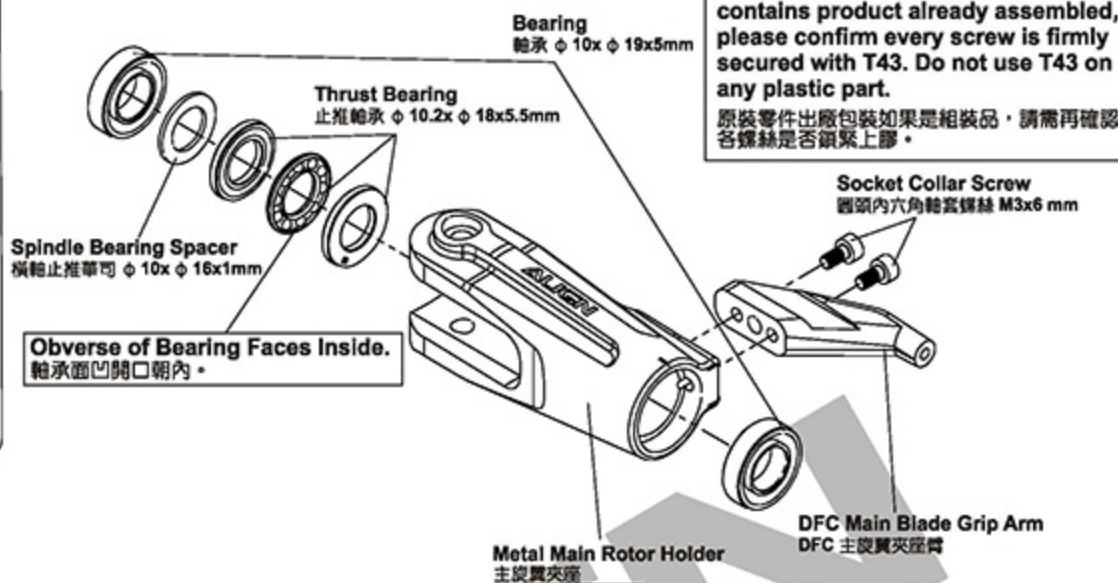

Apply a little amount of T43 thread lock when fixing a metal part.  
螺絲鎖附於金屬件時使用適量T43(螺絲膠)。

**CAUTION**  
注意

Original manufactory packages contains product already assembled, please confirm every screw is firmly secured with T43. Do not use T43 on any plastic part.

原裝零件出廠包裝如果是組裝品，請需再確認各螺絲是否鎖緊上膠。

**CAUTION**  
注意

Already assembled by Factory. Before flying, please check if the screws are fixed with glue. 原裝組裝完成品，每一次飛行前請先確認螺絲是否已上膠不會鬆動。

**CAUTION**  
注意

Thrust bearing and washer for radial bearing are wear items, and thus should be inspected for replacement after every 20 flights. For flights with high headspeed, the inspection interval should be reduced to ensure flight safety.

止推軸承及橫軸墊圈屬於飛行消耗品，建議每20趟定期檢查及更換，高主旋翼轉速飛行時，請縮短定期檢查之趟數，以確保飛行安全。

**CAUTION**  
注意

**Apply Grease On Thrust Bearing**

止推軸承塗上潤滑油

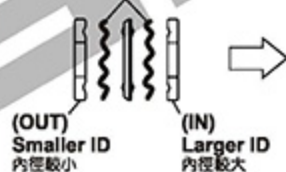

**THRUST BEARING** 止推軸承

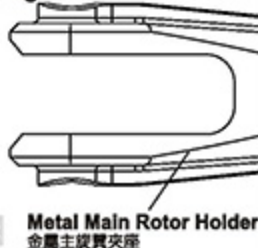

## 800FLH6



**Spindle Bearing Spacer**  
橫軸止推華司 (φ 10x φ 16x1mm) x 2



**Collar Screw**  
橫軸軸套螺絲 (M6x16mm) x 2



**Feathering Shaft Sleeve**  
橫軸套管 (φ 10.2x φ 17x21mm) x 2



**DFC Head Damper**  
DFC 橫軸墊圈 (φ 10x φ 17x7mm) x 2

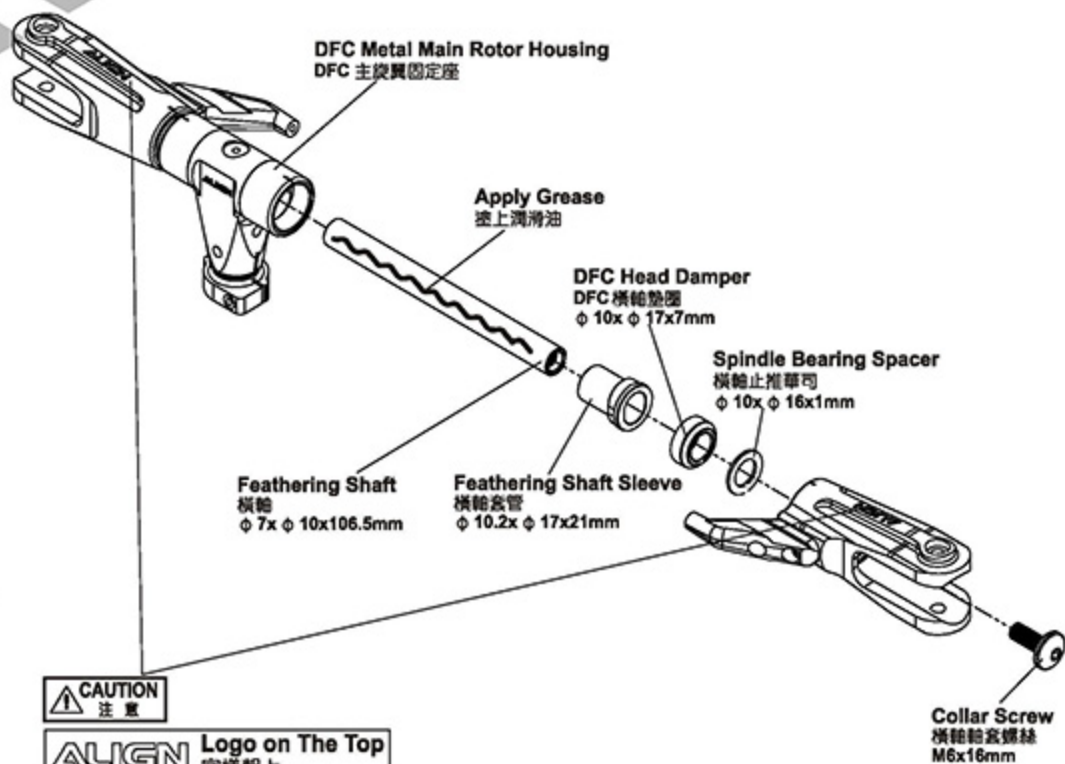

## 800FLH6

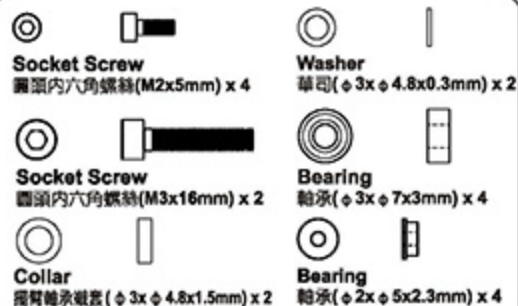

## 800FLH7

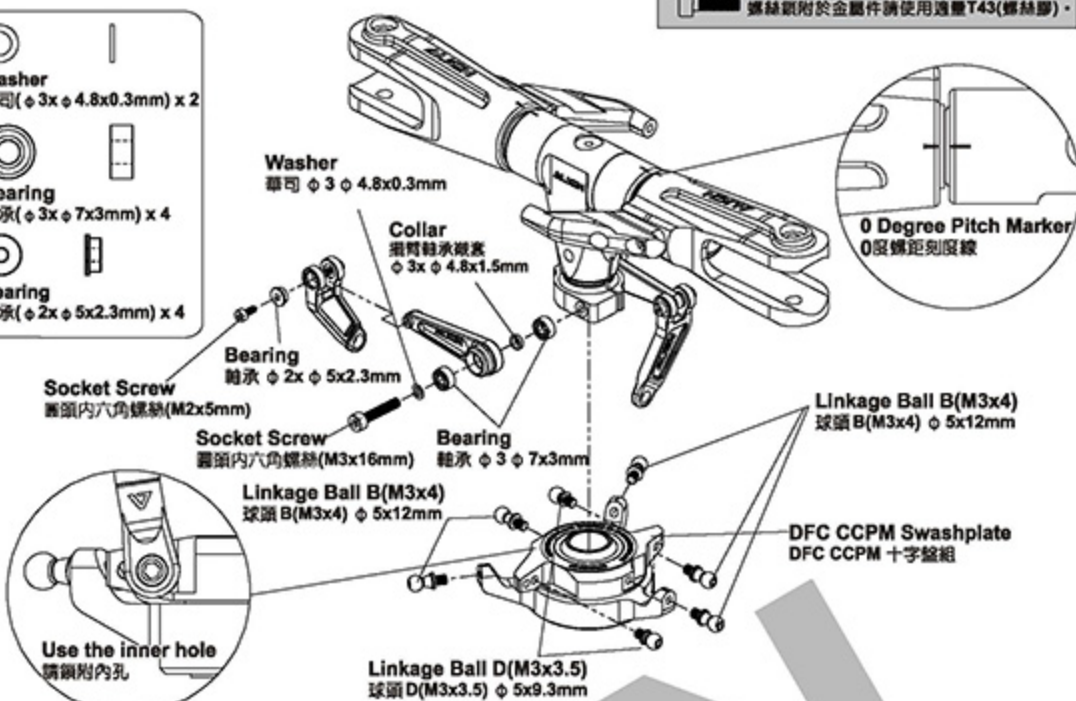

## 800FLH6



## 800FLH6A

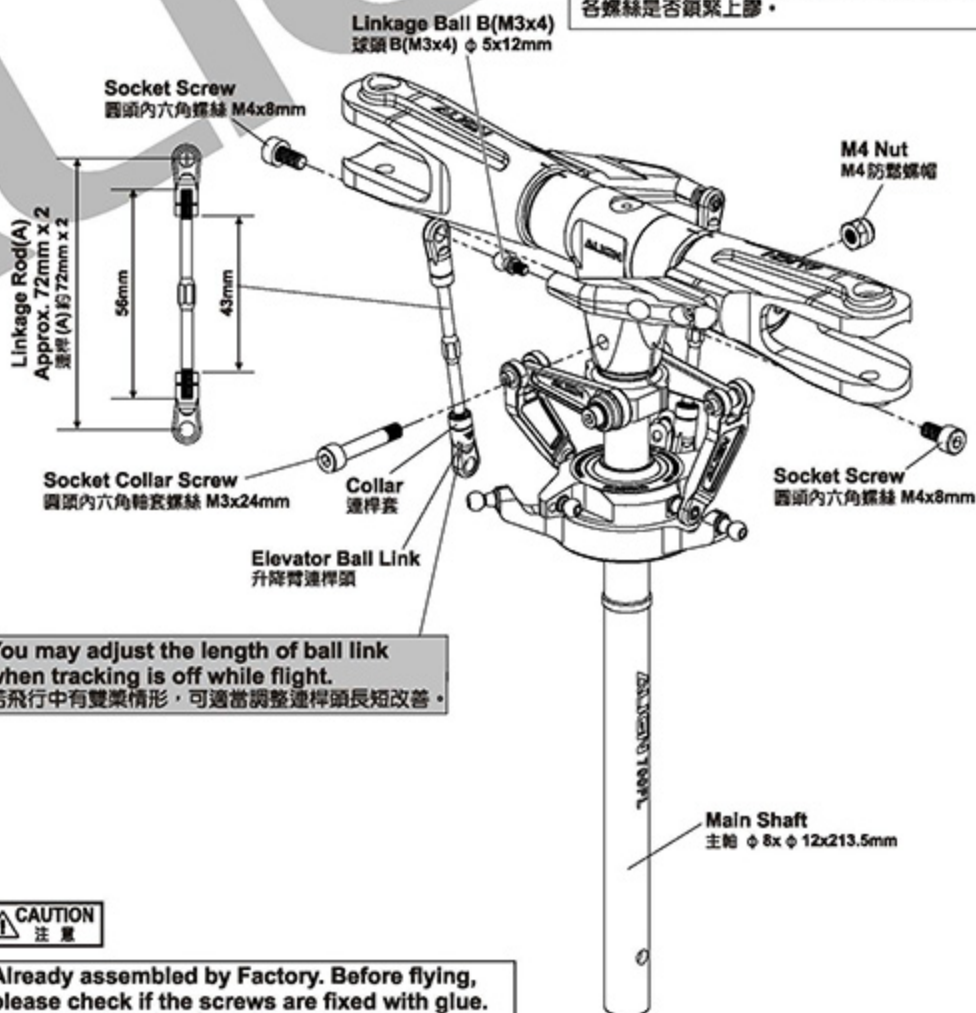



## 700HB3A



Frame Mounting Block  
機身固定塊

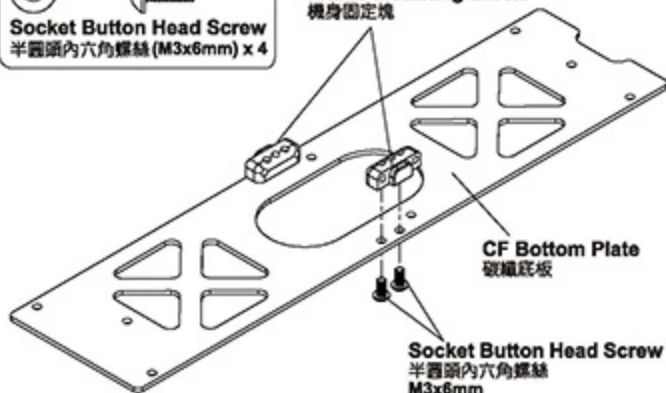

Socket collar screw  
特殊軸套螺絲  
M3x4.5mm



- Before assemble the main structure, please roughly bolt the special collar screw M3x4.5mm inside the main frame, and then go into next process of main structure assembly.
- After finished the main structure assembly, then screw up the special collar screw M3x4.5mm tightly.

- 機身側板組裝前，先將特殊軸套螺絲 M3x4.5mm，由側板內側將增強片虛鎖於側板上，接著再進行機身組裝。
- 待機身組立完成後，再將特殊軸套螺絲 M3x4.5mm 鎖緊。

## 800HB9

## 700HB3A



Already assembled by Factory.  
Before flying, please check if the screws are fixed with glue.  
原裝組裝完成品，每一次飛行前請先確認螺絲是否已上膠不會鬆動。

## 700HB9A

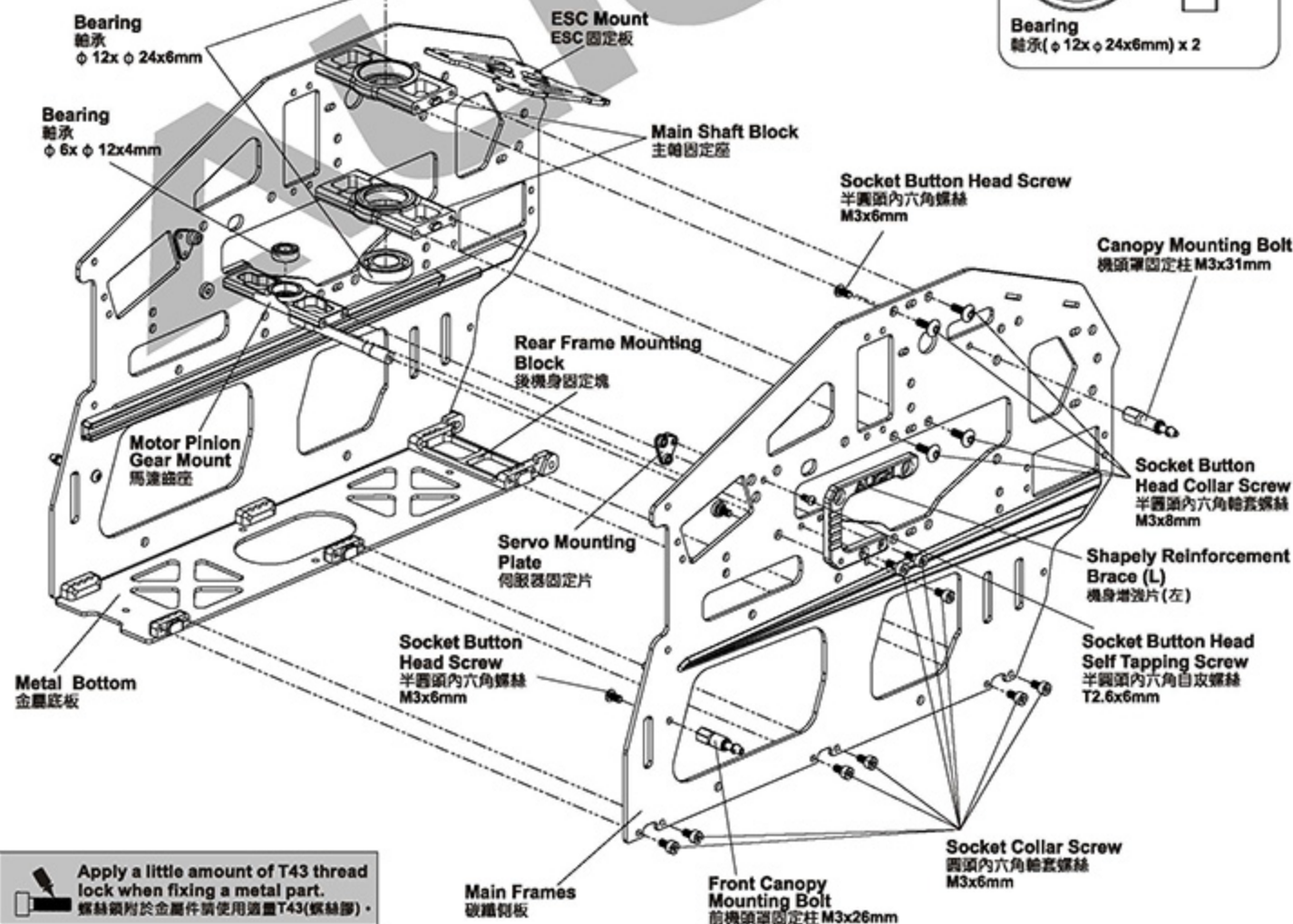

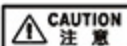
**Main frame assembly key point :**

First do not fully tighten the screws of main frames and put two bearings through the main shaft to check if the movements are smooth. The bottom bracket must be firmly touched the level table top(glass surface) ; please keep the smooth movements on main shaft and level bottom bracket, then slowly tighten the screws. This assembly can help for the power and flight performance.

**機身側板組立重點：**

側板螺絲先不完全鎖緊，放入主軸貫穿二顆軸承確認上下移動必需滑順，主體底板必須與水平桌面（玻璃平面）踏實緊貼；請保持主軸滑順與底板平行桌面後慢慢鎖緊螺絲。正確側板的組裝對動力與飛行性能有顯著幫助。

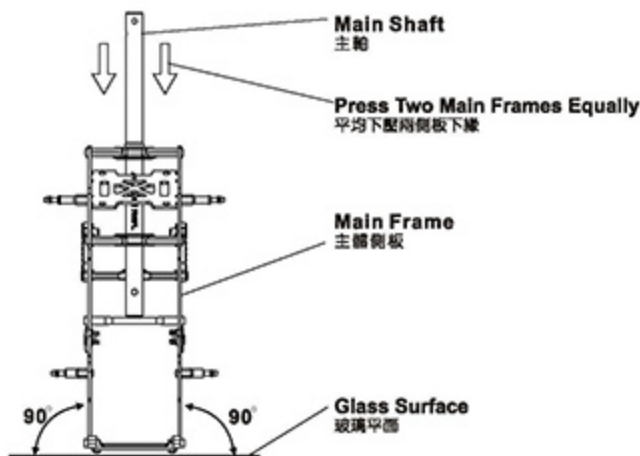
**700HG1A**

**M3 Washer**  
M3華司(φ3xφ8x1mm) x 4



**M3 Set Screw**  
M3止洩螺絲(M3x4mm) x 4



**Socket Screw**  
圓頭內六角螺絲(M3x10mm) x 4

**700HB10**

**Socket Button Head Self Tapping Screw**  
半圓頭內六角自攻螺絲(T3x8mm) x 1



**Socket Button Head Self Tapping Screw**  
半圓頭內六角自攻螺絲(T3x12mm) x 2

**700HB9A**

**Socket Collar Screw**  
圓頭內六角軸套螺絲(M3x6mm) x 2

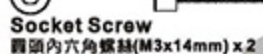

**Socket Screw**  
圓頭內六角螺絲(M3x14mm) x 2

Apply a little amount of T43 thread lock when fixing a metal part.  
螺絲鎖附於金屬件請使用適量T43(螺絲膠)。



**Original manufactory packages contains product already assembled, please confirm every screw is firmly secured with T43. Do not use T43 on any plastic part.**

原裝零件出廠包裝如果是組裝品，請需再確認各螺絲是否鎖緊上膠。

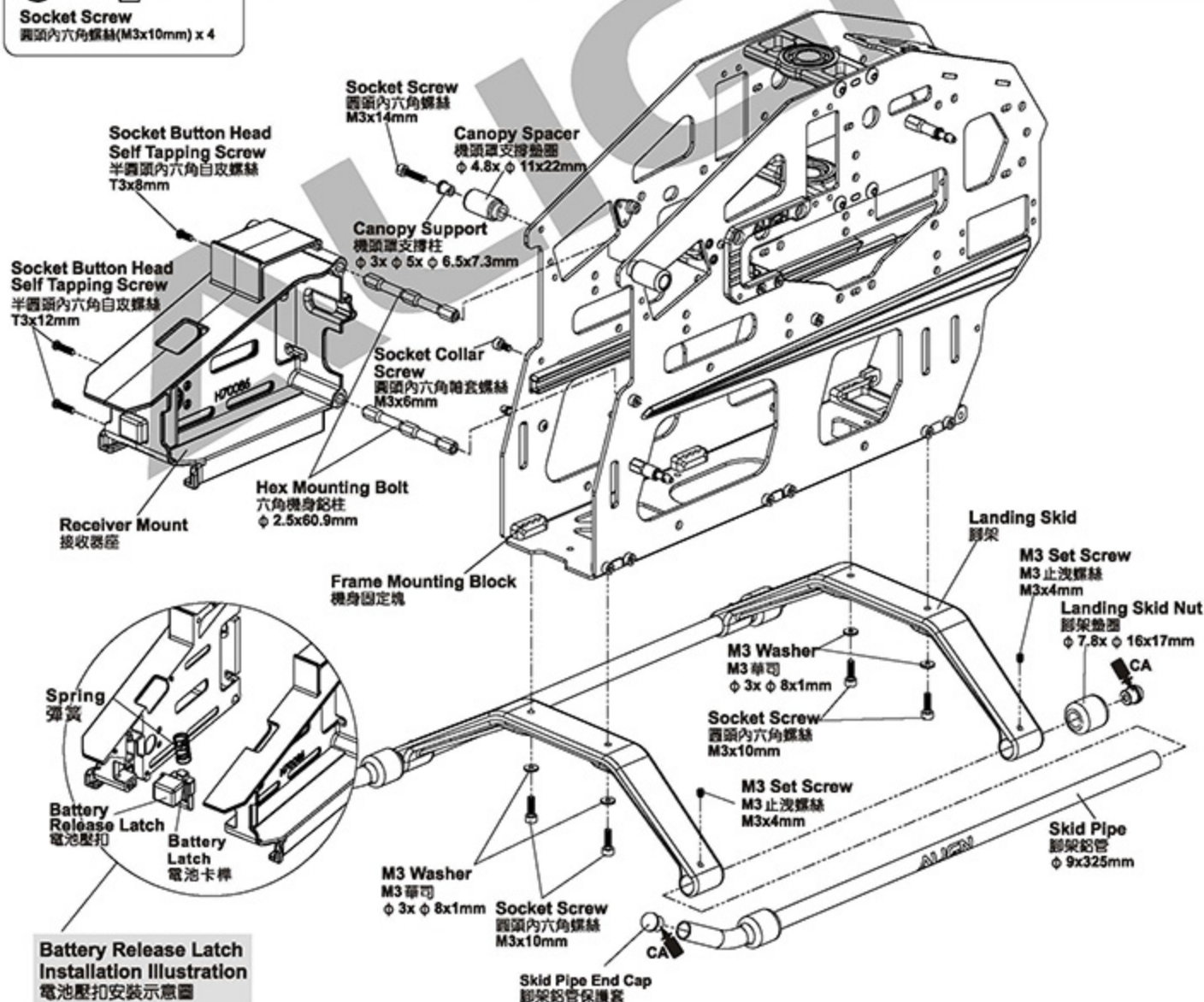

# 700HZ6



**Linkage Ball C(M2x4)**  
球頭 C(M2x4)( $\phi$  5x9mm) x 4



**Socket Button Head Self Tapping Screw**  
半圓頭內六角自攻螺絲 (T2.6x12mm) x 4



**Socket Button Head Screw**  
半圓頭內六角螺絲 (M2.5x12mm) x 4



**Socket Button Head Screw**  
半圓頭內六角螺絲 (M3x6mm) x 4

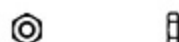

**M2 Nut**  
M2 螺帽 x 4

Apply a little amount of T43 thread lock when fixing a metal part.  
螺絲鎖附於金屬件時使用適量T43(螺絲膠)。

Recommend sanding the marked position as below illustration with a waterproof abrasive paper(#800-1000) to avoid the wires of electric parts to be cut.

建議於下圖色塊標示處，使用#800~1000水砂紙打磨，可防止電子設備電線被割破。

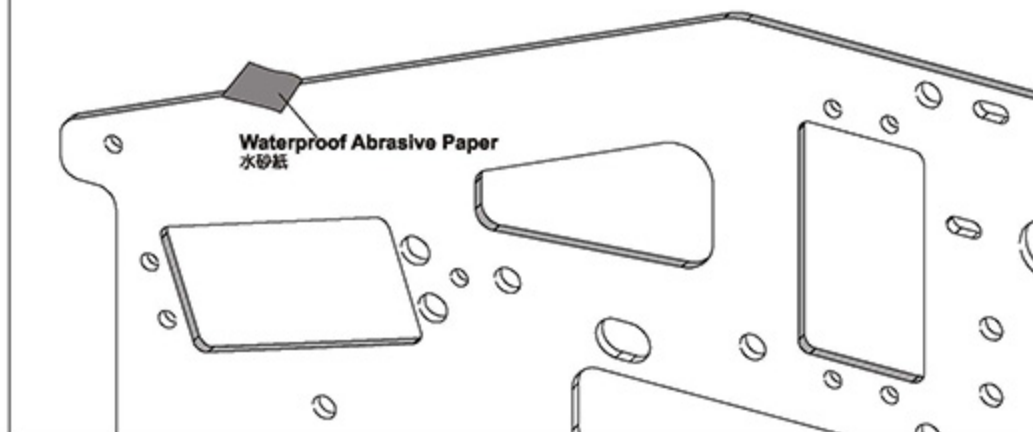

**BL815H High Voltage Brushless Servo**  
BL815H 高電壓無刷伺服馬達

**Metal Elevator Servo Mount**  
金屬升降伺服器座

**Socket Button Head Screw**  
半圓頭內六角螺絲 M2.5x12mm

**Linkage Ball C(M2x4)**  
球頭 C(M2x4)  $\phi$  5x9mm

**CNC Metal Servo Horn**  
CNC 金屬伺服器舵角片

**Use The Inner Hole**  
請鎖附內孔

**Socket Button Head Screw**  
半圓頭內六角螺絲 M3x6mm

**CF Servo Plate**  
碳纖維伺服器墊片

**M2 Nut**  
M2 螺帽

**F Servo Horns :**  
Compatible with Align BL7/BL8/DS6 series and Futaba servos.  
F 伺服器舵角片：  
適用於亞拓 BL7/BL8/DS6 系列伺服器及 Futaba 伺服器。

**BL815H High Voltage Brushless Servo**  
BL815H 高電壓無刷伺服馬達

**Linkage Ball C(M2x4)**  
球頭 C(M2x4)  $\phi$  5x9mm

**CNC Metal Servo Horn**  
CNC 金屬伺服器舵角片

**CF Servo Plate**  
碳纖維伺服器墊片

**M2 Nut**  
M2 螺帽

**Socket Button Head Self Tapping Screw**  
半圓頭內六角自攻螺絲 T2.6x12mm



**Original manufactory packages contains product already assembled, please confirm every screw is firmly secured with T43. Do not use T43 on any plastic part.**

原裝零件出廠包裝如果是組裝品，請需再確認各螺絲是否鎖緊上膠。

- BL815H High Voltage Brushless Servo :**
- 1.1520  $\mu$  s standard band / 1520  $\mu$  s 寬頻系統
  - 2.Stall torque/輸出扭力 : 17.0kg.cm(6.0V)  
22.0kg.cm(7.4V)  
23.0kg.cm(8.4V)
  - 3.Motion speed/動作速度 : 0.075sec/60° (6.0V)  
0.060sec/60° (7.4V)  
0.055sec/60° (8.4V)
  - 4.Dimension/尺寸 : 40 x 20 x 39.1mm
  - 5.Weight/重量 : 80g

**700HZ6**

**Socket Button Head Screw**  
半圓頭內六角螺絲(M2.5x12mm) x 4

**Socket Button Head Self Tapping Screw**  
半圓頭內六角自攻螺絲(T2.6x12mm) x 4

**Linkage Ball C(M2x4)**  
球頭C(M2x4)( $\phi$  5x9mm) x 1

**M2 Nut**  
M2螺帽 x 1

**700HZ11**

**Washer**  
華司( $\phi$  6x $\phi$  9x0.6mm) x 1

**700HB3A**

**Socket Button Head Collar Screw**  
半圓頭內六角帽蓋螺絲(M3x8mm) x 8

**700HZ11**

**Socket Screw**  
圓頭內六角螺絲(M4x10mm) x 4

**M4 Washer**  
M4華司( $\phi$  4x $\phi$  10x1mm) x 4

**M4 Set Screw**  
M4止洩螺絲(M4x4mm) x 2

**CAUTION**  
注意

Make sure the motor mount is fully fastened before fasten the motor pinion gear mount.  
先將馬達固定座鎖緊固定後，再將馬達齒座鎖緊。

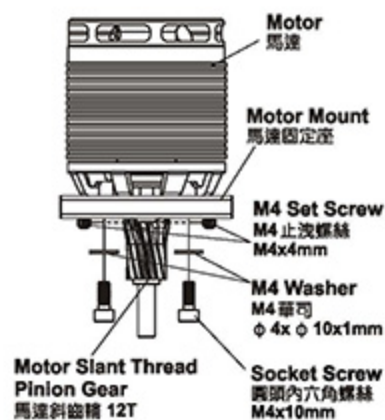

While assembling the motor mount, please make sure to properly loose M4 Set screw on 12T motor gear first, after fully fasten the motor mount with the motor pinion, then fasten back the M4 Set screw completely.

安裝馬達座時，請先將12T馬達斜齒的M4x4mm止洩螺絲適當放鬆，當馬達固定座和馬達齒座固定鎖好後，再將馬達止洩螺絲鎖緊。

**CAUTION**  
注意

Make sure the motor mount is fully fastened before fasten the motor pinion gear mount.  
先將馬達固定座鎖緊固定後，再將馬達齒座鎖緊。

Apply a little amount of T43 thread lock when fixing a metal part.  
螺絲鎖附於金屬件請使用適量T43(螺絲膠)。

**CAUTION**  
注意

Original manufactory packages contains product already assembled, please confirm every screw is firmly secured with T43. Do not use T43 on any plastic part.  
原裝零件出廠包裝如果是組裝品，請再確認各螺絲是否鎖緊上膠。

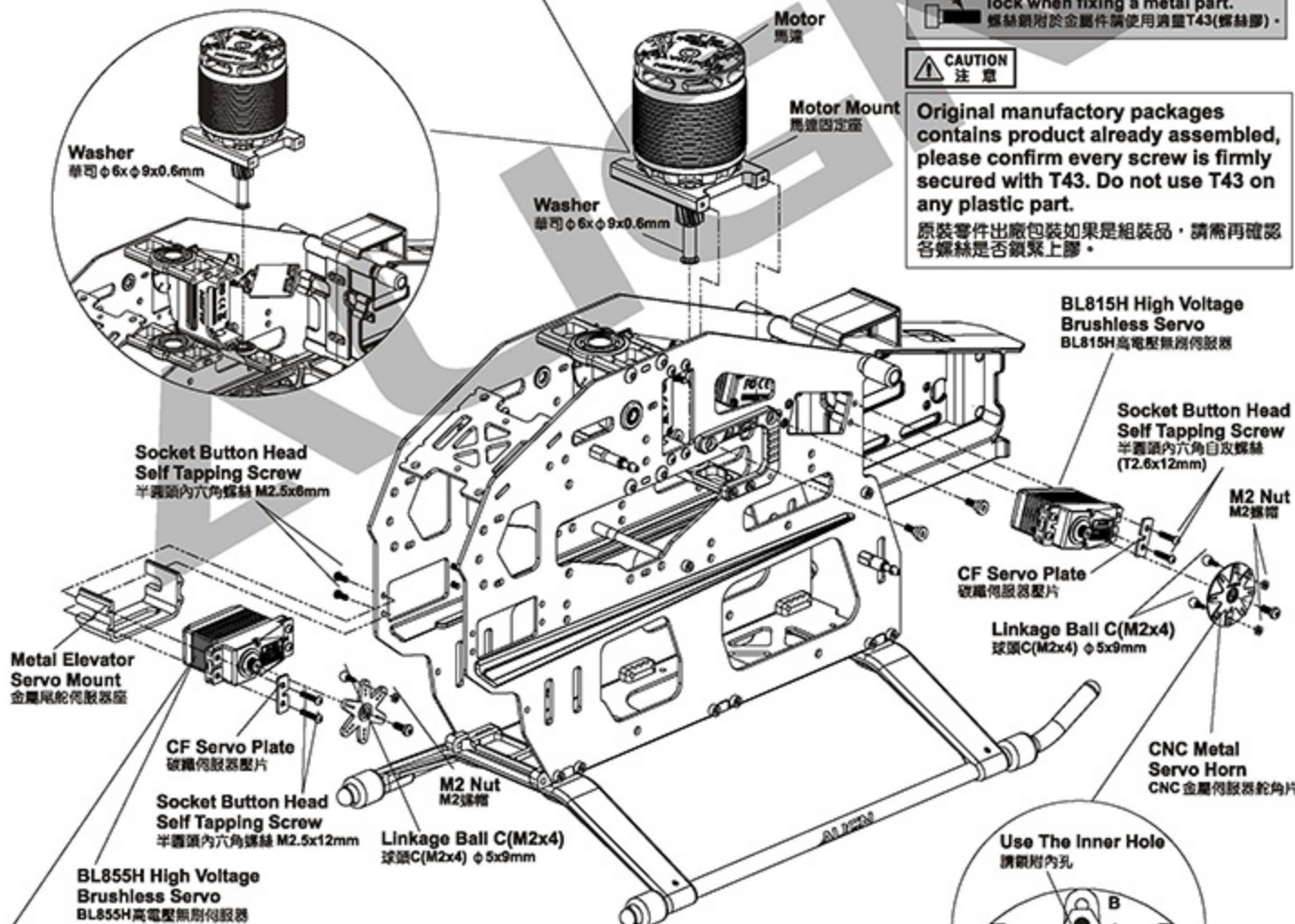

**BL855H High Voltage Brushless Servo :**  
1.1520  $\mu$ s Standard Band /1520  $\mu$ s 寬頻系統  
2.Stall Torque/輸出扭力 : 8.0kg.cm(6.0V)  
10.0kg.cm(7.4V)  
12.5kg.cm(8.4V)  
3.Motion Speed/動作速度 : 0.04sec/60° (6.0V)  
0.03sec/60° (7.4V)  
0.028sec/60° (8.4V)  
4.Dimension/尺寸 : 40 x 20 x 39.1mm  
5.Weight/重量 : 73g

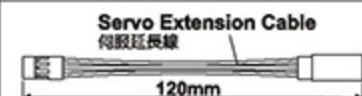

For Extend The Rudder Servo Signal Cable.  
尾舵伺服器訊號線延長用

Use The Inner Hole  
請鎖附內孔



**F Servo Horns :**  
Compatible with Align BL7/BL8/DS6 series and Futaba servos.  
F 伺服器舵角片 :  
適用於亞拓 BL7/BL8/DS6 系列伺服器及 Futaba 伺服器。



Please fasten the elevator ball link and screws all the way in.  
升降臂連桿頭及螺絲請鎖緊。

### 800HB9

**Bearing**  
軸承 (φ 5x φ 9x3mm) x 4

**Control Shaft Collar**  
運動桿套圈 (φ 5x φ 7.5x3mm) x 2

**Bearing**  
軸承 (φ 3x φ 7x3mm) x 2

**Collar**  
升降運動控制臂軸套 (φ 3x φ 4.5x1.5mm) x 2

**Socket Button Head Screw**  
半圓頭內六角螺絲 (M3x6mm) x 2

**Socket Button Head Screw**  
半圓頭內六角螺絲 (M3x8mm) x 2

**M4 Set Screw**  
M4 止洩螺絲 (M4x4mm) x 1

### 700HB3A

**Linkage Ball C (M3x3.5)**  
球頭 C (M3x3.5) (φ 5x8.5mm) x 6

**Linkage Ball B (M3x4)**  
球頭 B (M3x4) (φ 5x12mm) x 2

**Socket Screw**  
圓頭內六角螺絲 (M3x8mm) x 1

**Washer**  
華司 (φ 3x φ 5.5x0.3mm) x 2

**Washer**  
華司 (φ 5x φ 7x0.2mm) x 2

**Washer**  
華司 (φ 5x φ 7x0.5mm) x 2

**Elevator Ball Link**  
升降臂連桿頭

### 700HZ8

**Linkage Rod (B)**  
連桿 (B) φ 1.96x10mm x 2



Flybarless system uses inner hole(A)  
Flybar system uses outer hole(B)  
無平衡翼系統使用內孔(A)  
有平衡翼系統使用外孔(B)

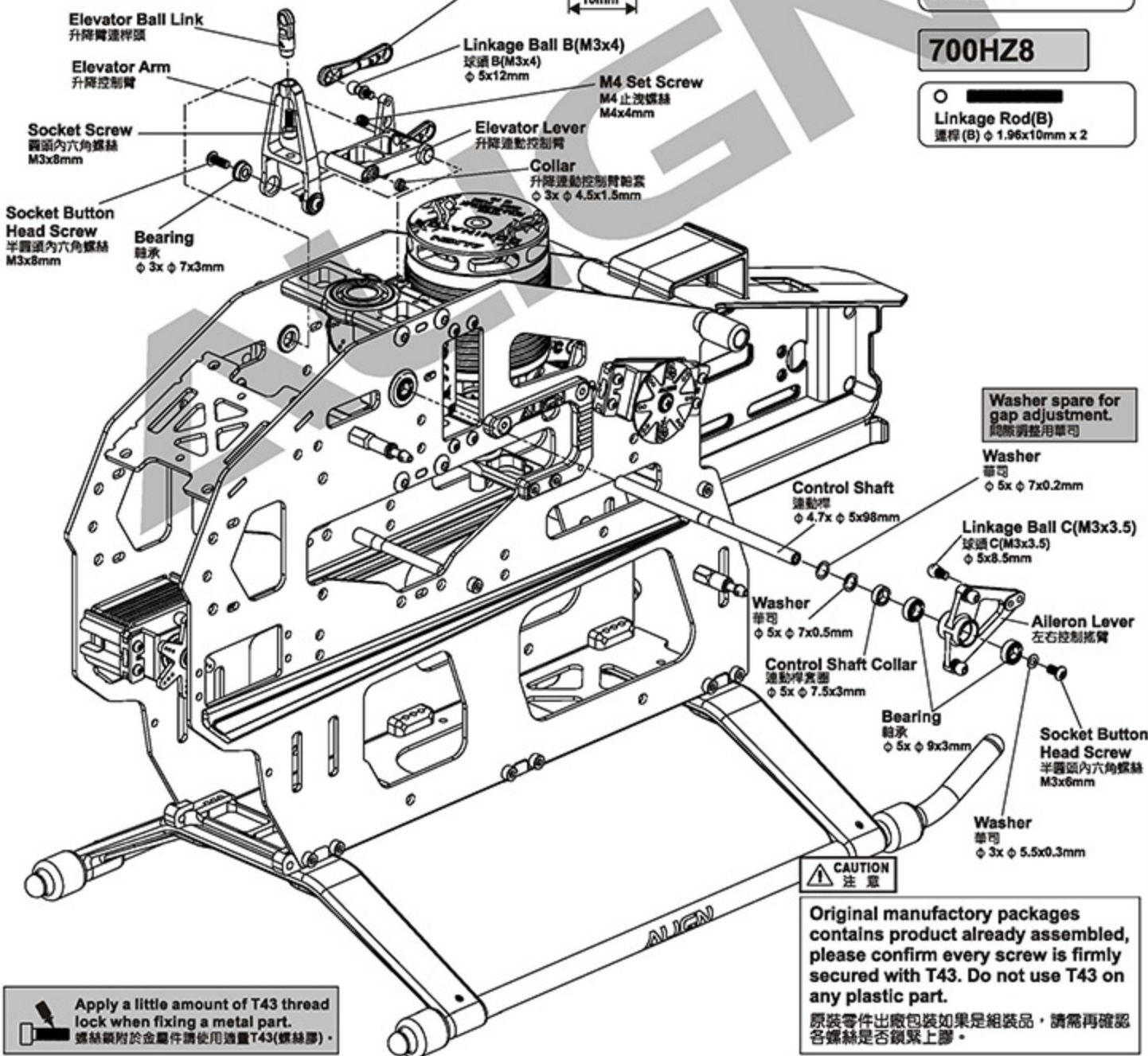
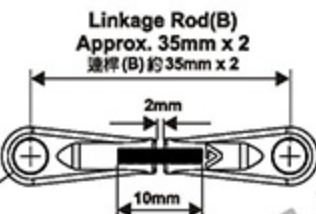

Original manufactory packages contains product already assembled, please confirm every screw is firmly secured with T43. Do not use T43 on any plastic part.  
原裝零件出廠包裝如果是組裝品，請再次確認各螺絲是否鎖緊上膠。

Apply a little amount of T43 thread lock when fixing a metal part.  
螺絲鎖附於金屬件請使用適量T43(螺絲膠)。

## 800HZ7

◎   
**Aileron Control Rod Carbon Fiber Tube**  
 升降控制連桿碳纖維管 (φ 2.2x φ 3.9x96mm) x 4

○   
**Linkage Rod(E)**  
 連桿 (E) φ 2x110mm x 4

## 700HZ8A

  
**Ball link**  
 連桿頭 x 8

◎   
**Aileron Control Rod Carbon Fiber Shaft**  
 升降控制連桿碳纖維套 (φ 4x φ 5.4x6.5mm) x 8

### AILERON CARBON FIBER LINKAGE ROD SET

### 副翼控制碳纖維連桿組要領



- 1: Mix thoroughly suitable amount of epoxy.
- 2: Apply generous amount of epoxy on the tips of carbon tube after sliding over the linkage rod. (Suggest to use the AB glue that hardened in 30 mins.)  
 (Note: for quick drying epoxy, work fast as it must be applied prior to curing)

- 1: 使用適量的AB膠，並且均勻的攪拌混合
- 2: 將已套入連桿的碳纖維管兩端塗上AB膠 (建議使用30分鐘硬化的AB膠)  
 (注意: 若使用速乾型AB膠請務必於膠乾固前組裝完成)



- 3: Slide the carbon end caps on both sides of the carbon tube.
- 3: 接著將碳纖維套分別套入碳纖維管兩端



- 4: Thread the ball links onto the linkage rod until the base to base length is 97.5mm.
- 4: 將連桿頭鎖入連桿至跨距為97.5mm的位置



- 5: If gap exists between the ball link and end caps after correct length has been achieved, slide the end caps outwards to cover the gaps  
 (note: must be done before epoxy cures)

- 6: Wipe away excess epoxy and set it aside to cure.

- 5: 碳纖維套與連桿頭會有些許的間隙，此時請將碳套往兩側推至切齊連桿頭  
 (注意: 須在AB膠未乾固時完成此動作)

- 6: 將多餘的殘膠擦拭乾淨後請靜置AB膠乾固方可使用

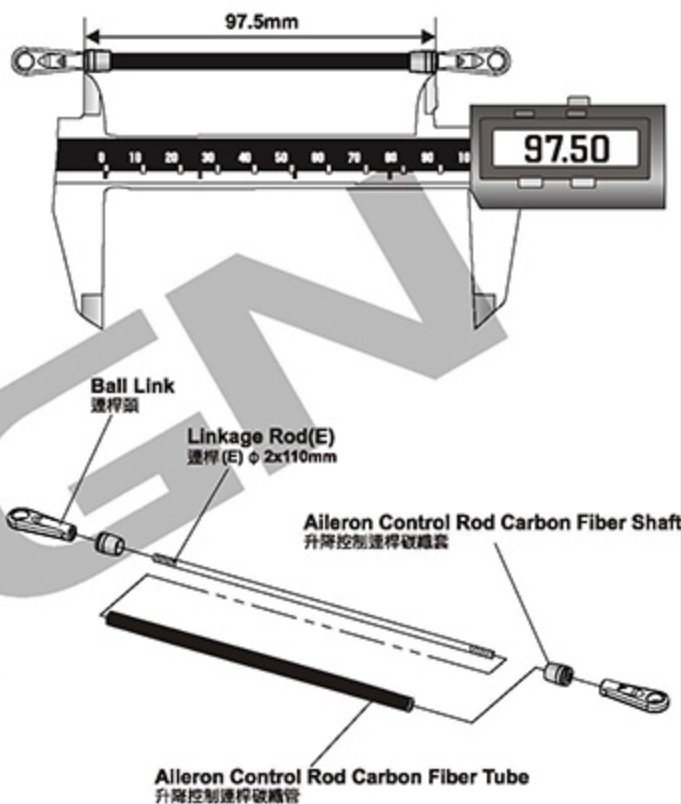

Linkage Rod(E)  
Approx. 130mm x 4  
連桿 (E) 約 130mm x 4

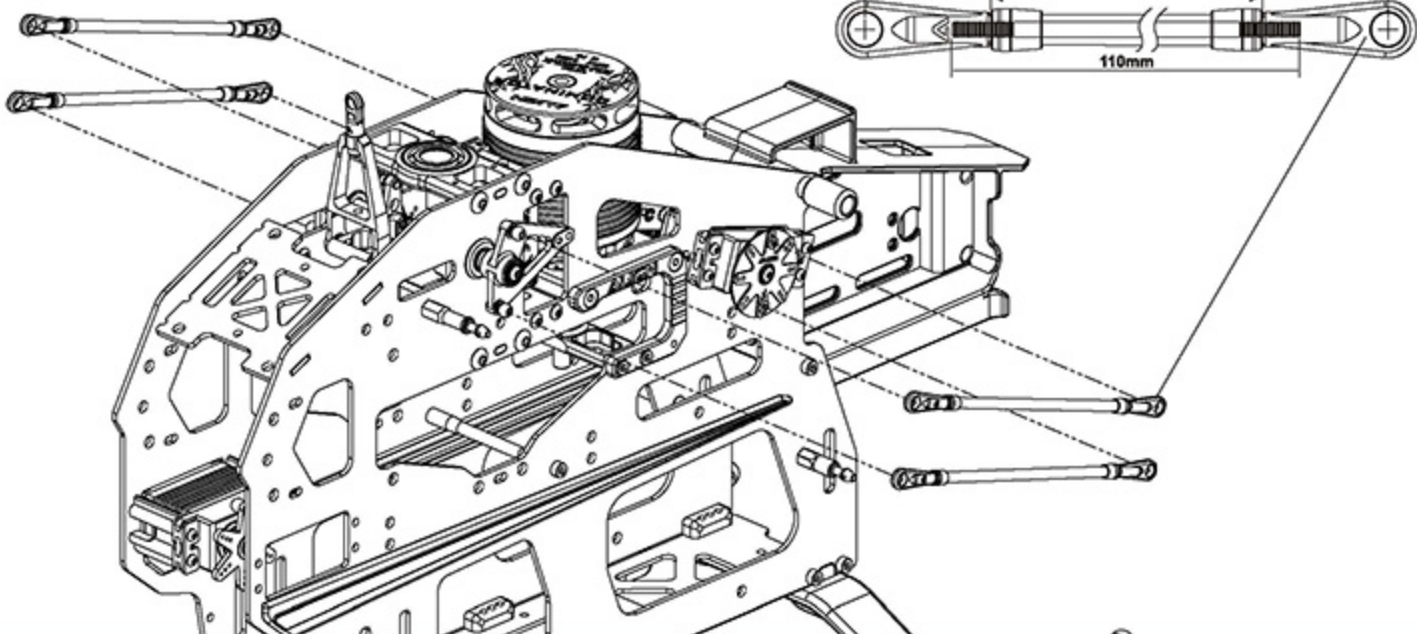

## 800HT1

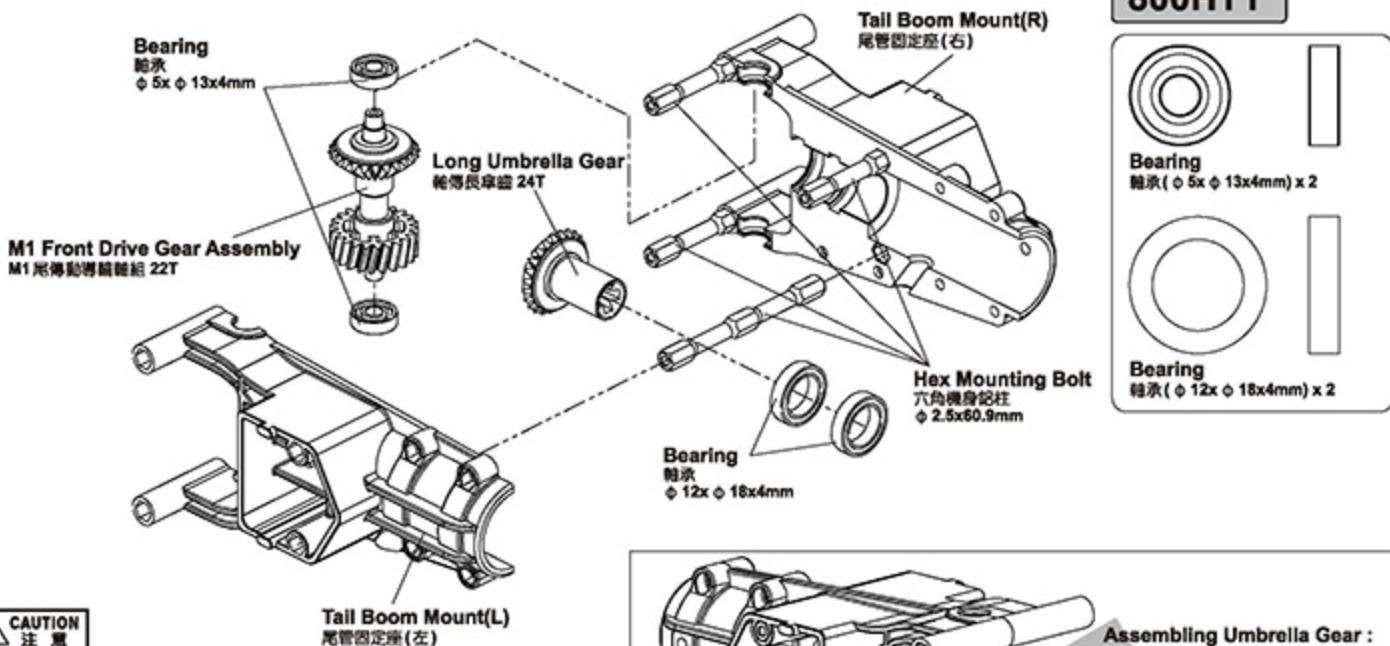

**CAUTION**  
注意

Original manufactory packages contains product already assembled, please confirm every screw is firmly secured with T43. Do not use T43 on any plastic part.

原裝零件出廠包裝如果是組裝品，請需再確認各螺絲是否鎖緊上膠。

**Assembling Umbrella Gear :**  
Please note to push the gear to the end at a fixed position, to make sure the gears mesh with each other smooth.

傘齒組裝：注意務必前推到固定位，以免齒咬合不順暢。

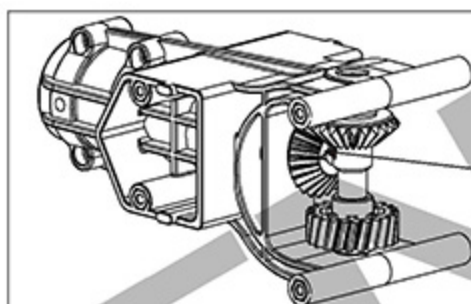

## 800HT8

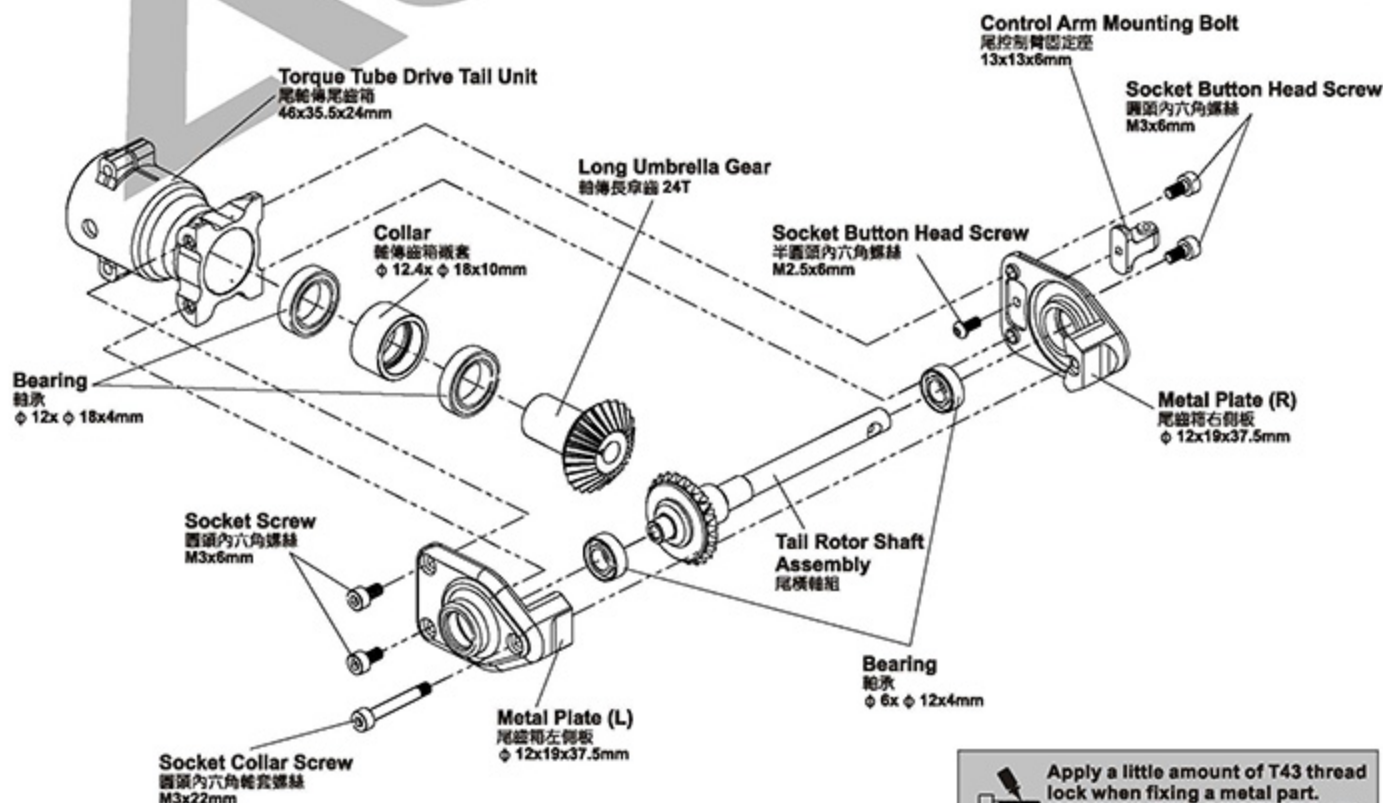
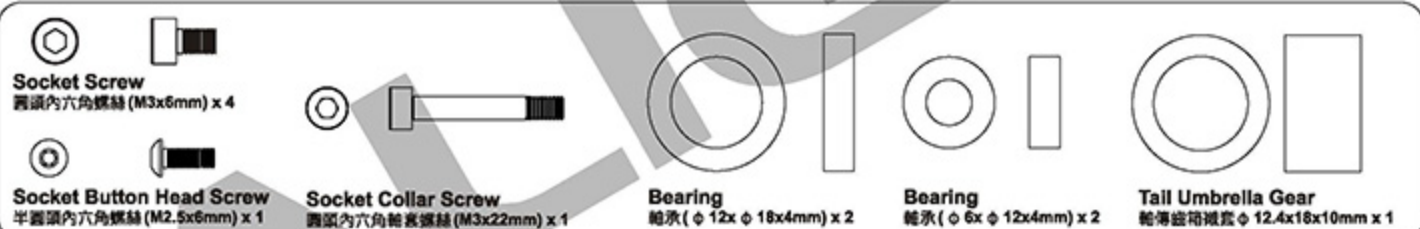

Apply a little amount of T43 thread lock when fixing a metal part.  
螺絲鎖附於金屬件請使用適量T43(螺絲膠)。

# 800HT8

**Collar Screw**  
軸套螺絲-銀 (M2x8mm)(牙長3mm) x 2

**Collar Screw**  
軸套螺絲 (M2x8mm)(牙長4.3mm) x 2

**Socket Screw**  
圓頭內六角螺絲 (M2x8mm) x 2

**Collar A**  
尾連桿頭銷套 A (φ 2x φ 3x4mm) x 2

**Bearing**  
軸承 (φ 8x φ 12x3.5mm) x 2

**Slide Shaft**  
尾輪滑套 x1

**Bearing**  
軸承 (φ 2.5x φ 7.1x2.6mm) x 6

**Socket Button Head Screw**  
半圓頭內六角螺絲 (M2.5x5mm) x 6

**Socket Collar Screw**  
圓頭內六角軸套螺絲 (M3x8mm) x 2

**Thrust Bearing**  
止推軸承 (φ 5x φ 10x4mm) x 2

**Bearing**  
軸承 (φ 6x φ 10x3mm) x 4

**Washer**  
華司 (φ 3x φ 8x1mm) x 2

**M4 Set Screw**  
M4 止洩螺絲 (M4x4mm) x 1

**Washer**  
華司 (φ 8x φ 10x0.3mm) x 2

**M4 Set Screw**  
M4 止洩螺絲 (M4x4mm) x 1

**Washer**  
華司 (φ 8x φ 10x0.3mm) x 2

**Washer**  
華司 (φ 8x φ 10x0.3mm) x 2

**Washer**  
華司 (φ 8x φ 10x0.3mm) x 2

**Socket Button Head Screw**  
半圓頭內六角螺絲 (M3x5mm) x 1

**Linkage Ball C (M2x4)**  
球頭C (M2x4)(φ 5x9mm) x 1

# 800HT9

**Socket Collar Screw**  
圓頭內六角軸套螺絲 (M3x17mm) x 2

**M3 Nut**  
M3 防鬆螺帽 x 2

## CAUTION 注意

**Apply Grease on Thrust Bearing.**  
止推軸承塗上潤滑油

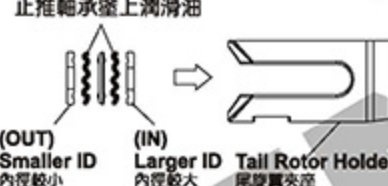

**THRUST BEARING 止推軸承**

Apply a little amount of T43 thread lock when fixing a metal part.  
螺絲鎖附於金屬件時請使用適量T43(螺絲膠)。

## CAUTION 注意

Original manufactory packages contains product already assembled, please confirm every screw is firmly secured with T43. Do not use T43 on any plastic part.

原裝零件出廠包裝如果是組裝品，請需再確認各螺絲是否鎖緊上膠。

Please tighten M2x8mm collar screw firmly but not over tightened. Over tighten the screw will cause the operation of control link unsmoothly.  
鎖附 M2x8mm 軸套螺絲請使用適當力道，過度鎖緊會造成尾控制連桿轉動不順。

## CAUTION 注意

Aim tail rotor hub at the concave of tail rotor shaft and fix it, please apply a little glue on the set screw.  
尾旋翼 T 型座對準尾旋翼軸的凹刻並鎖上，請確認止洩螺絲上膠。

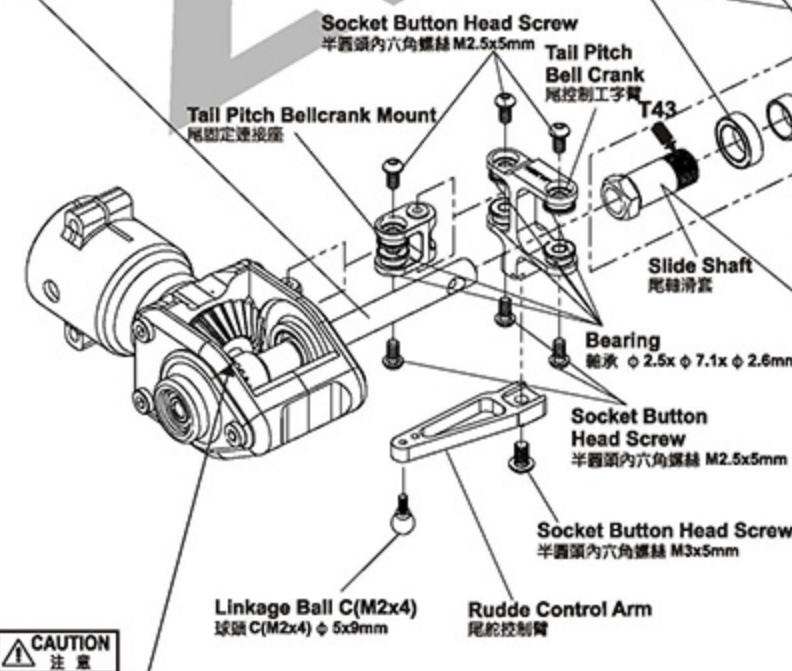

## CAUTION 注意

Assembling Umbrella Gear: Please note to push the gear to the end at a fixed position, to make sure the gears mesh with each other smoothly.  
傘齒組裝，請注意務必前推到定位，以避免齒咬合不順暢。

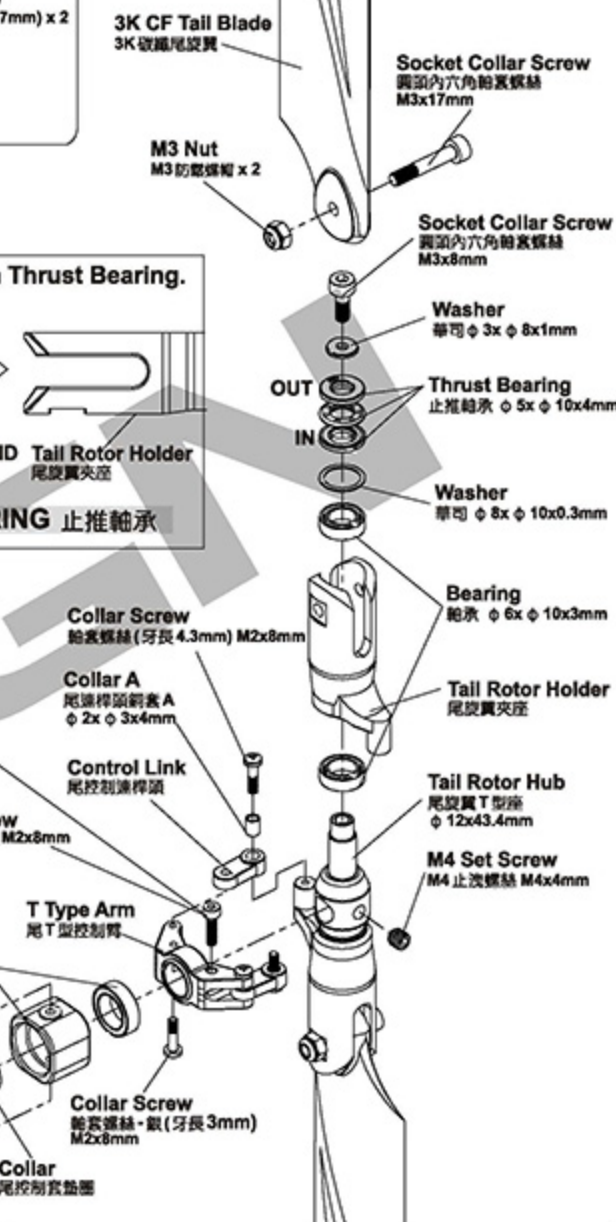

While assembly the slide shaft, please use suitable amount of T43 on the thread. Please do not use R48 anaerobics retainer or other high strength glue to avoid damages while maintenance or repairs.  
組立尾輪滑套時，請使用適量的 T43 螺絲膠在螺牙上，嚴禁使用 R48 高膠合性軸承膠防止膠合過緊，以避免日後拆修維護零件之損傷。

## CAUTION 注意

After complete the tail rotor assembly, please check if it rotates smoothly.  
尾旋翼組裝完成後需確認尾旋翼夾座轉動滑順。

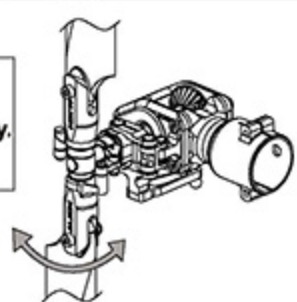



Already assembled by factory,  
please note to check again.  
已組裝完成，請務必自行再確認。

When assembling into the tail boom, please apply some oil on the surface, to make it smooth during the assembling and keep it vertical with the torque tube for smooth rotation.  
插入尾管內時，外表抹些潤滑油，以確保平順壓入尾管中並與尾傳動軸保持垂直，讓尾輪傳動順暢。

When assembling the tail boom, please aim at the fixing hole  $\phi 5.1$   
裝入尾管時請注意孔對準尾管  $\phi 5.1$  固定孔

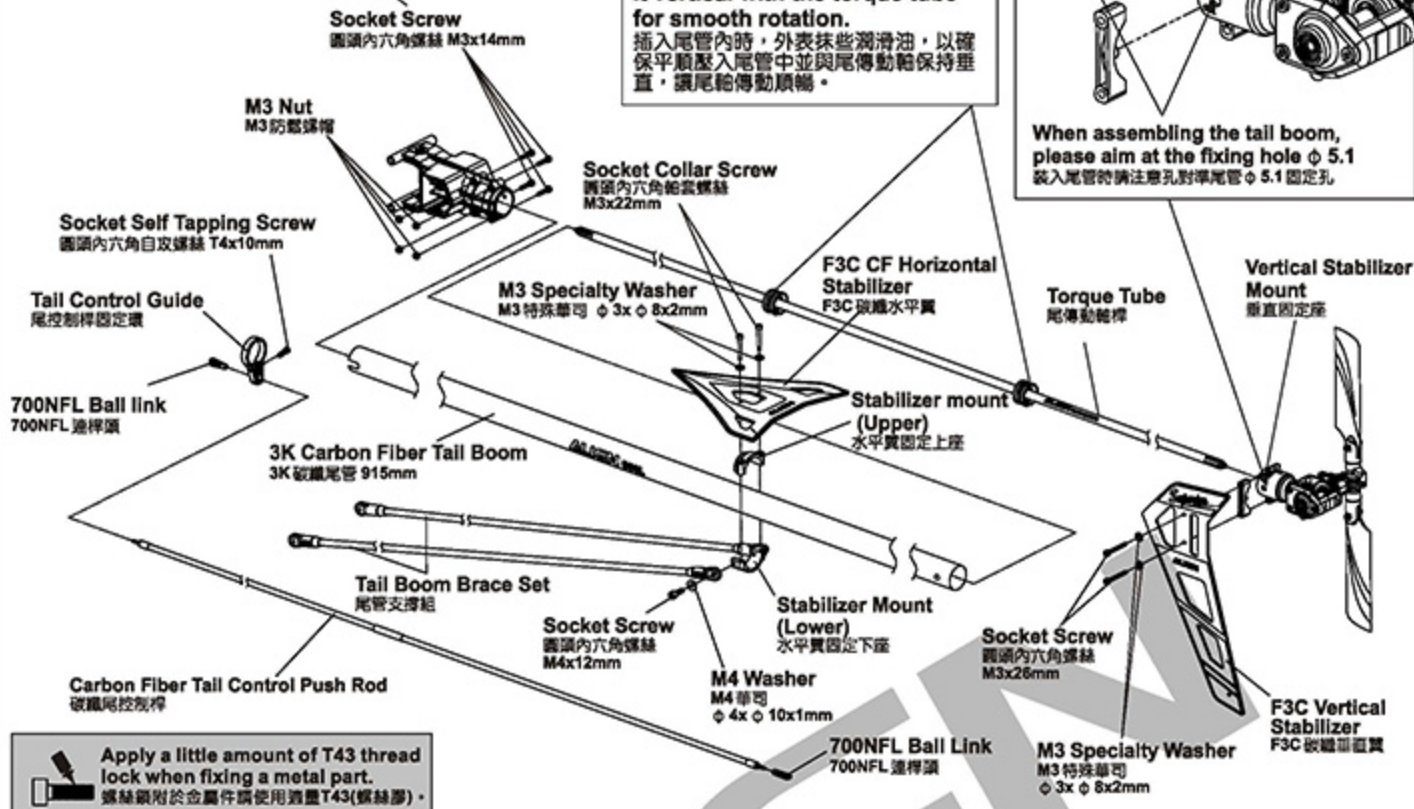

Apply a little amount of T43 thread lock when fixing a metal part.  
螺絲鎖附於金屬件請使用適量T43(螺絲膠)。

### 700NT1A



### 800HT4A



### 800HT8



### TIP TO FIX THE TORQUE TUBE 傳動軸軸承固定位要領

Please apply some CA glue to fix bearing on the torque tube, avoid CA glue from the dust or may cause the bearing stuck. When assembling into the tail boom, please apply some oil and use the attached torque tube mount helper to press the bearing holder of the torque tube into the tail boom horizontally.  
請以少量CA將軸承固定於尾傳動軸上，避免CA沾到軸承的防塵蓋而導致軸承卡死，插入尾管內時，尾傳動軸承墊圈外表抹些潤滑油，利用隨附軸承安裝套管將尾傳動軸承墊圈平行壓入尾管中不可歪斜。

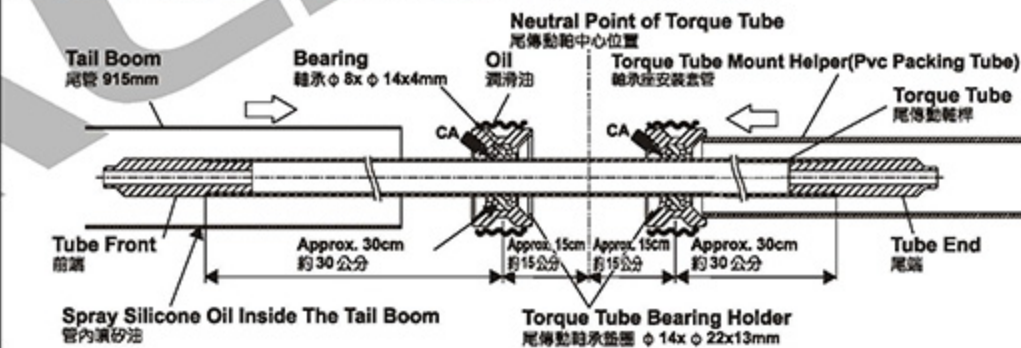

### 800HT5

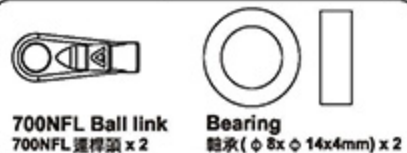

### 800HT6



CAUTION 注意

Skewed torque tube bearing holder will interfere with torque tube rotation and cause unusual vibration.  
尾傳動軸承安裝歪斜會造成傳動軸運轉不順及尾部異常震動等問題。

CAUTION 注意

After moving the tail control rod adjustment sleeve to recommended position, glue the sleeve to carbon tail control rod with instant glue.  
尾控制桿固定環調整至建議位置後，再將尾控制桿固定環套與碳纖維尾控制桿接觸面以適量瞬間膠固定。

Apply a little amount of T43 thread lock when fixing a metal part.  
 螺絲鎖附於金屬件請使用適量T43(螺絲膠)。

Tail Boom Fixing Screw  
 尾管固定螺絲

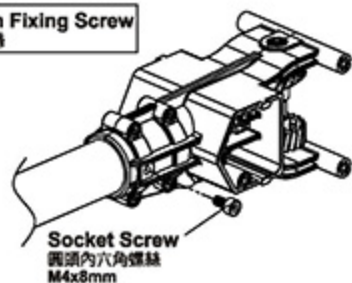

Socket Screw  
 圓頭內六角螺絲  
 M4x8mm

Socket Button Head Collar Screw  
 半圓頭內六角輪套螺絲  
 M3x8mm

Socket Screw  
 圓頭內六角螺絲 M4x14mm

M4 Washer  
 M4 華司  $\phi 4 \times 10 \times 1 \text{mm}$

700NT1A

700HB11A



Socket Screw  
 圓頭內六角螺絲 (M4x8mm) x 1



Socket Button Head Collar Screw  
 半圓頭內六角輪套螺絲 (M3x8mm) x 8



Socket Screw  
 圓頭內六角螺絲 (M4x14mm) x 2



M4 Washer  
 M4 華司 ( $\phi 4 \times 10 \times 1 \text{mm}$ ) x 2

Please fasten the screws to the  $\phi 3.0$  holes of the slant main gear.  
 螺絲鎖附於斜主齒輪  $\phi 3.0$  孔位

Washer  
 華司  $\phi 3 \times 4.8 \times 0.6 \text{mm}$

CNC Slant Thread Main Drive Gear  
 CNC 斜主齒輪 112T

Before tightening the screw, please rotate the bearing and check the concentricity of the bearing in order to have the screw firmly secured, to avoid the bearing stuck or heavy load at one side and cause slip.

上緊螺絲前需試轉動確認軸承同心度良好後，才能將螺絲平均鎖緊，以避免造成卡死或單向重負載可能產生的打滑。

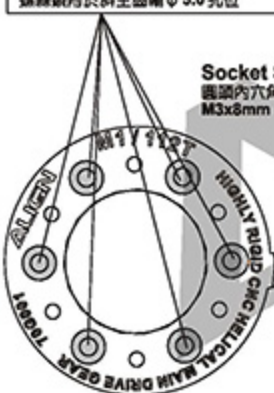

Socket Screw  
 圓頭內六角螺絲  
 M3x8mm

One-way Bearing Shaft  
 單向軸承套  $\phi 12 \times 15 \times 41.5 \text{mm}$

Apply Grease  
 塗上潤滑油

One-way Bearing Collar  
 單向軸承外環  
 $\phi 6 \times 23 \times 11.6 \text{mm}$

Please Note The Direction of Bearing.  
 請注意軸承方向

Spacer  
 700 單向墊片  
 $\phi 18 \times 22.7 \times 0.7 \text{mm}$

One-way bearing  
 單向軸承  
 $\phi 15 \times 23 \times 11 \text{mm}$

700HB14

One-way Bearing Cover  
 單向軸承上蓋  
 $\phi 21 \times 15.8 \times 26 \text{mm}$

Bearing  
 軸承  $\phi 15 \times 21 \times 4 \text{mm}$

Socket Screw  
 圓頭內六角螺絲 M2.5x8mm

M1 Autorotation Tail Drive Gear Set  
 M1 尾驅動主齒組 104T

One-way Bearing Mount  
 單向軸承下座  
 $\phi 21 \times 6.5 \times 33.1 \text{mm}$



Bearing  
 軸承 ( $\phi 15 \times 21 \times 4 \text{mm}$ ) x 2



Spacer  
 700 單向墊片  $\phi 18 \times 22.7 \times 0.7 \text{mm}$  x 1

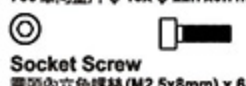

Socket Screw  
 圓頭內六角螺絲 (M2.5x8mm) x 6

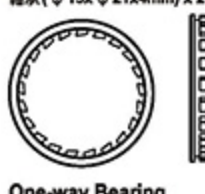

One-way Bearing  
 單向軸承 ( $\phi 15 \times 23 \times 11 \text{mm}$ ) x 1

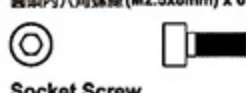

Socket Screw  
 圓頭內六角螺絲 (M3x8mm) x 6



Washer  
 華司  $\phi 3 \times 4.8 \times 0.6 \text{mm}$  x 6

CAUTION  
 注意

Already assembled by Factory. Before flying, please check if the screws are fixed with glue.  
 原廠組裝完成品，每一次飛行前請先確認螺絲是否已上膠不會鬆動。

## 800FLH6A

### Main Blade Fixing Screw 鎖主旋翼用螺絲



Socket Collar Screw  
圓頭內六角軸套螺絲 (M5x32mm) x 2



M5 Nut  
M5 防鬆螺帽 x 2

When tightening the main blade fixing screw, please tighten it firmly, but not over tighten, or it may cause the damage of main blade holder and result in danger.  
鎖緊主旋翼螺絲須注意適當緊度即可，過緊可能導致主旋翼夾座受損，飛行意外發生。

Socket Collar Screw  
圓頭內六角軸套螺絲 M5x32mm

780 Carbon Fiber Blades  
780 碳纖維主旋翼

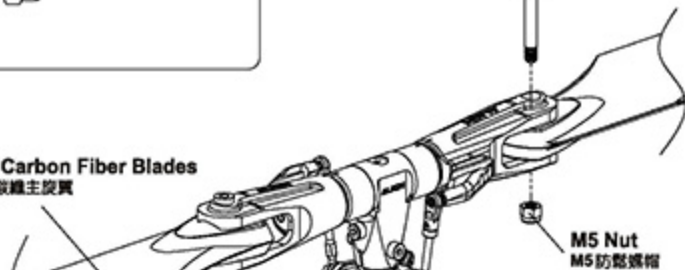

Linkage Rod(B)  
連桿 (B) M3x44mm  
(牙長 8.5mm)

Elevator Ball Link  
升降桿連桿頭

Linkage Rod(B)  
連桿 (B) 60mm x 2

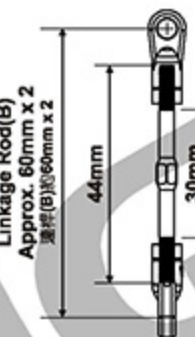

Standard Equipment:  
Main Shaft Spacer(1)  
標準品：主軸墊片 (1)  $\phi$  12x  $\phi$  16x1mm

Spare part: Main Shaft Spacer(1.2)  
Main Shaft Spacer(0.8)  
Main Shaft Spacer(0.5)  
備品：主軸墊片 (1.2)  $\phi$  12x  $\phi$  16x1.2mm  
主軸墊片 (0.8)  $\phi$  12x  $\phi$  16x0.8mm  
主軸墊片 (0.5)  $\phi$  12x  $\phi$  16x0.5mm

## 700HB14

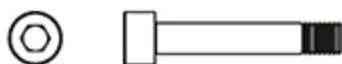

Socket Collar Screw  
圓頭內六角軸套螺絲 (M4x27mm) x 1

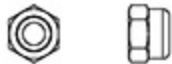

M4 Nut  
M4 防鬆螺帽 x 1

## 800HZ7



Linkage Rod(B)  
連桿 (B) M3x44mm (牙長 8.5) x 2

## 700HZ8A



Ball Link  
連桿頭 x 4

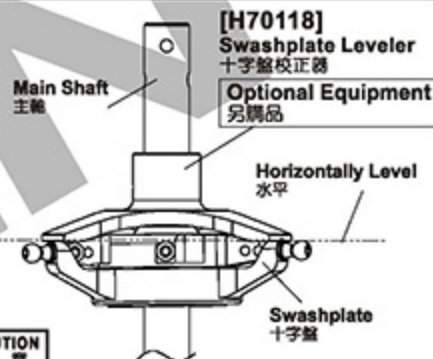

CAUTION  
注意

While using Flybarless system, please use the swashplate leveler to calibrate swashplate. Adjust the length of servo linkage rod to make sure the swashplate is leveled before start setting up to ensure the gyro provides the best performance.

使用無平衡系統，請務必使用十字盤調整器校正十字盤，調整伺服器連桿長度，確保十字盤達到水平狀態，再進行基本機體設定，這樣才能確保飛行性能達到最佳效果。

M1 Slant Thread  
Main Drive Gear Set  
M1 斜主齒輪組



Socket Collar Screw  
圓頭內六角軸套螺絲  
M4x27mm

M4 Nut  
M4 防鬆螺帽

The lower edge of main gear need to be lined up with lower edge of pinion gear. This will ensure smooth meshing, and avoid interference between pinion's base and main gear which can lead to unusual wear.

馬達齒下緣必須與主齒輪下緣水平切齊，如此才能確保齒輪傳動順暢，避免馬達主齒輪與新型斜主齒輪產生異常干涉磨損。

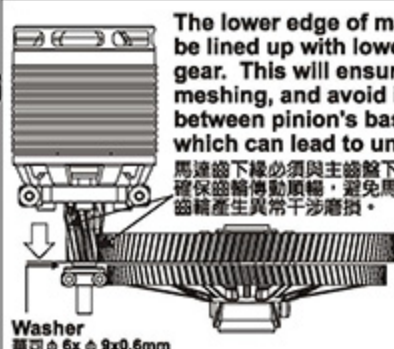

Washer  
華司  $\phi$  6x  $\phi$  9x0.6mm

Apply a little amount of T43 thread lock when fixing a metal part.  
螺絲鎖附於金屬件請使用適量 T43 (螺絲膠)。

**A MOUNTING ORIENTATION OF MICROBEAST PLUS MICROBEAST PLUS的安裝方向**

Please visit Align download area to get the completed instruction manual at Align website.

更多詳細的設定操作說明請至官網下載專區下載。

<http://www.align.com.tw/beastx/>

Microbeast PLUS can be installed on any position of helicopter. V4.x.x provides 8 different direction choices.

Microbeast PLUS 可以安裝在機體的任何一個位置。V4.x.x版本提供8種不同方向供你選擇。

**THE COLOR OF THE STATUS-LED SHOWS THE CURRENTLY SELECTED ORIENTATION:**

LED指示燈狀態顯示安裝方向：



Status LED Off\*  
Status-LED 燈熄滅\*



Status LED Flashing Purple  
Status-LED 燈紫色閃爍



Status LED Purple  
Status-LED 燈紫色



Status LED Flashing Red  
Status-LED 燈紅色閃爍



Status LED Red  
Status-LED 燈紅色



Status LED Flashing Blue  
Status-LED 燈藍色閃爍



Status LED Blue  
Status-LED 燈藍色



Status LED Flashing Red/Blue  
Status-LED 燈紅色/藍色同時閃爍

Front  
機頭方向

\* Factory Setting

\* 出廠預設值



Apply a little amount of T43 thread lock when fixing a metal part.  
螺絲鎖附於金屬件請使用適量T43(螺絲膠)。



Original manufactory packages contains product already assembled, please confirm every screw is firmly secured with T43. Do not use T43 on any plastic part.

原裝零件出廠包裝如果是組裝品，請再確認各螺絲是否鎖緊上膠。

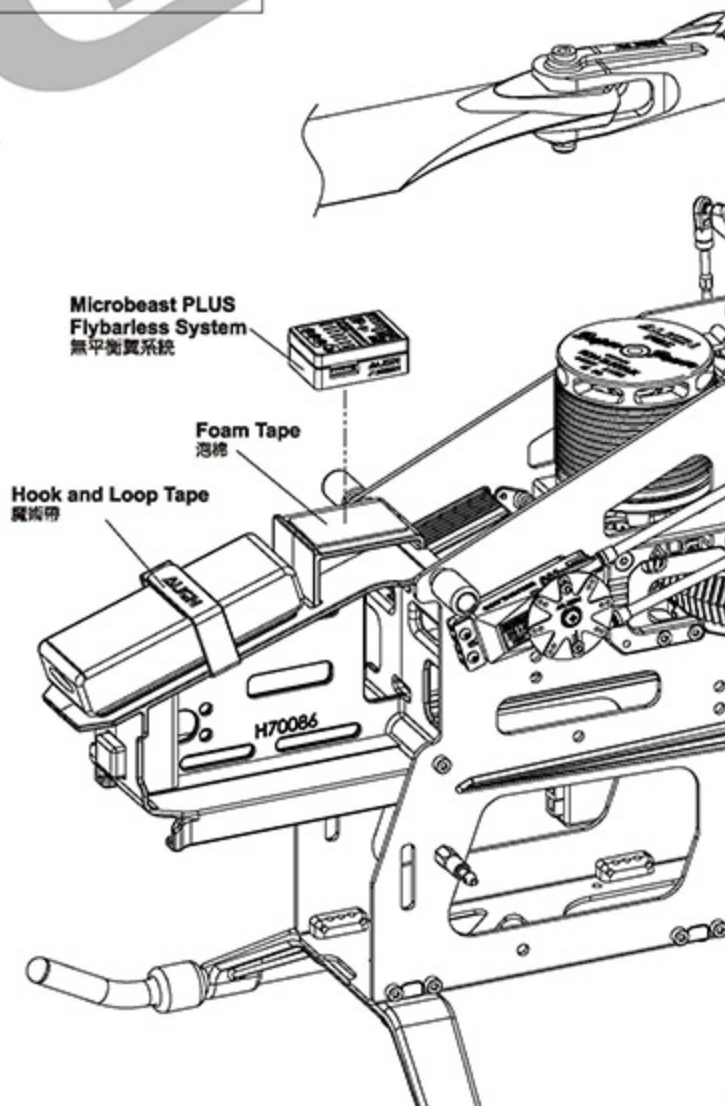
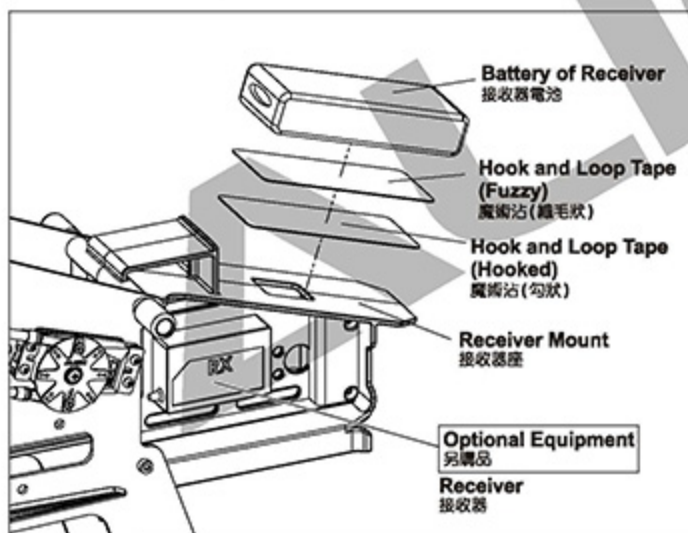



Please Fix The 2 Batteries On The Battery Mount Evenly.

2顆電池請平均固定於電池板上。

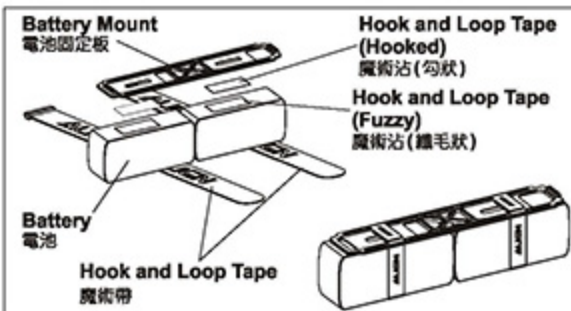

Slide the battery mounting plate along the rail until a "click" is heard to make sure the battery mounting plate is latched.

將電池固定板順著電池滑軌裝入至發出"喀答"聲響，使電池固定板卡入卡榫。

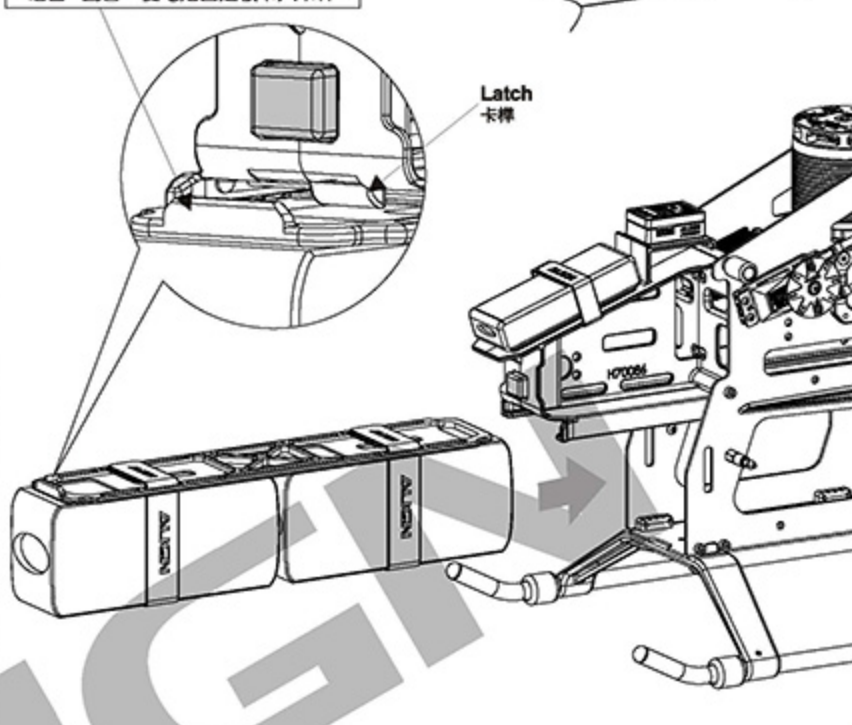

INSERT THE BATTERY FROM THE FRONT  
電池從前方置入

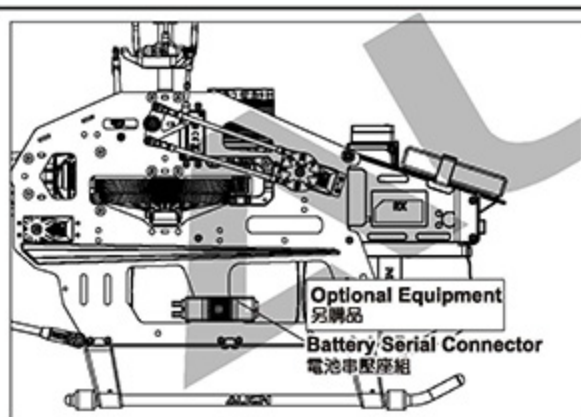
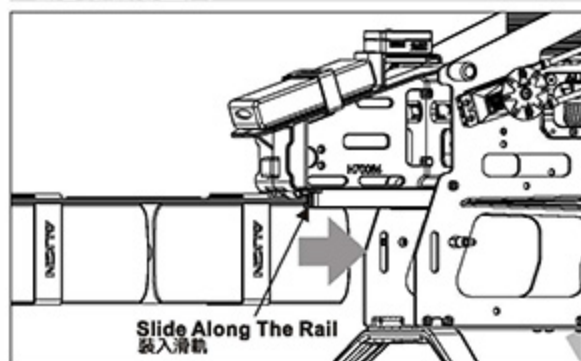

Press this latch to allow the battery to slide out along the rail.  
電池抽出前請先將電池壓扣往內壓，順著滑軌抽出

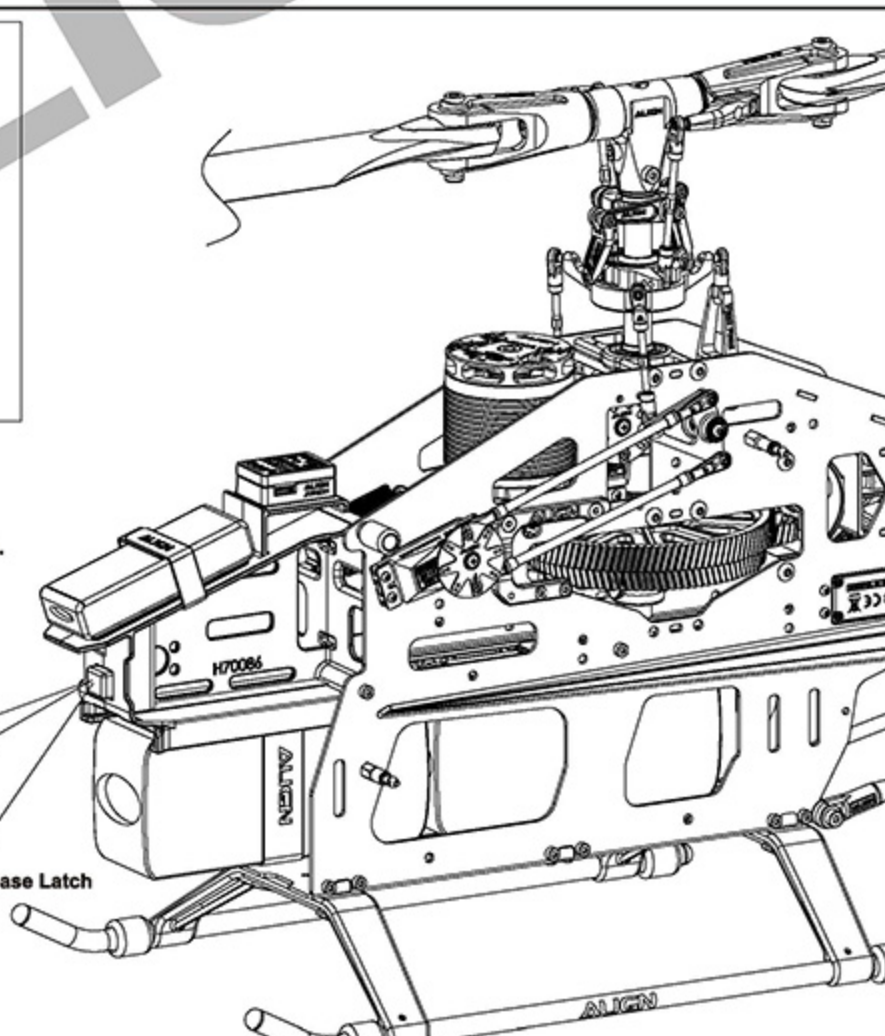
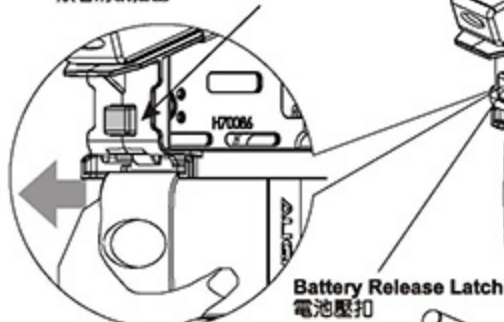

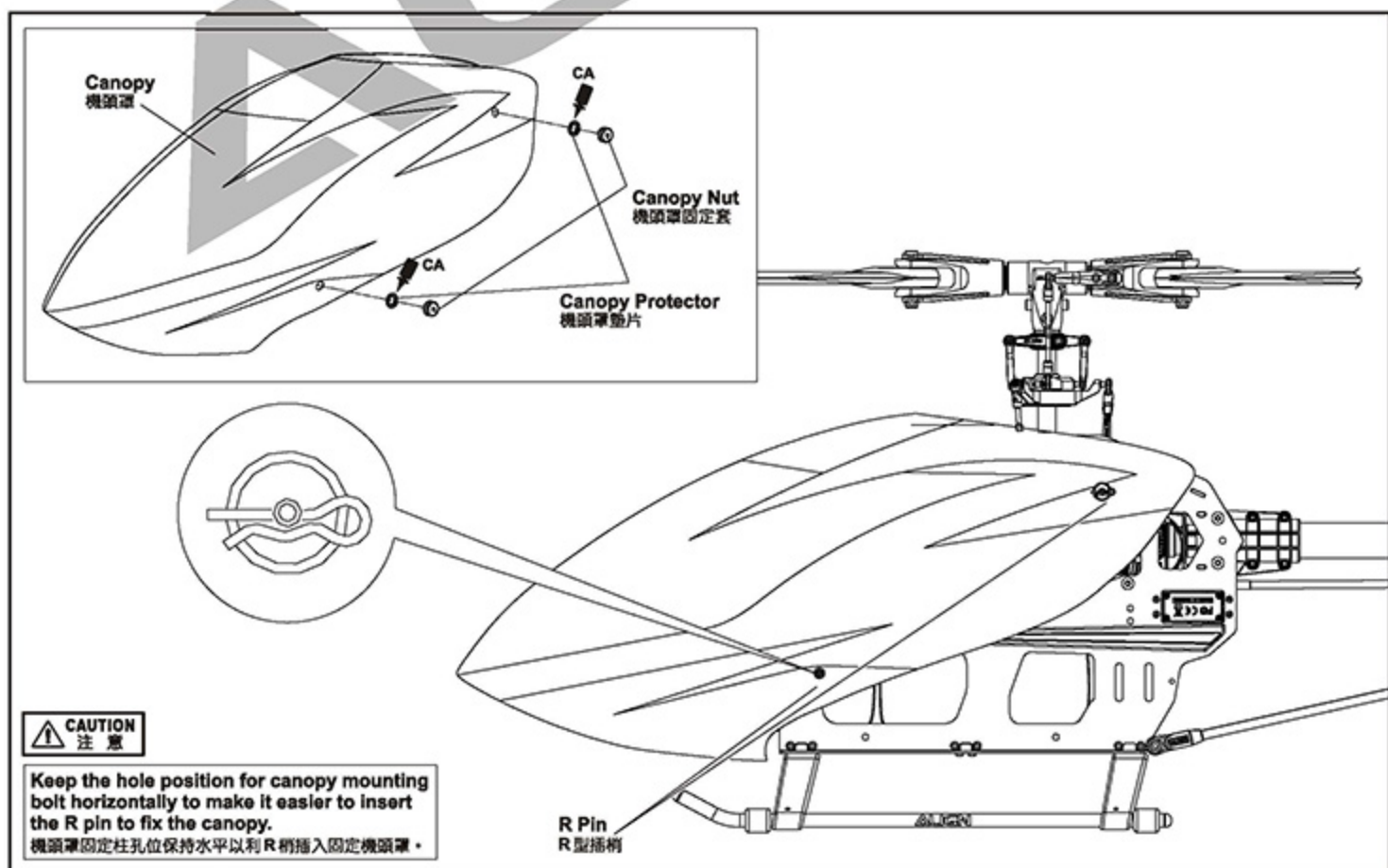
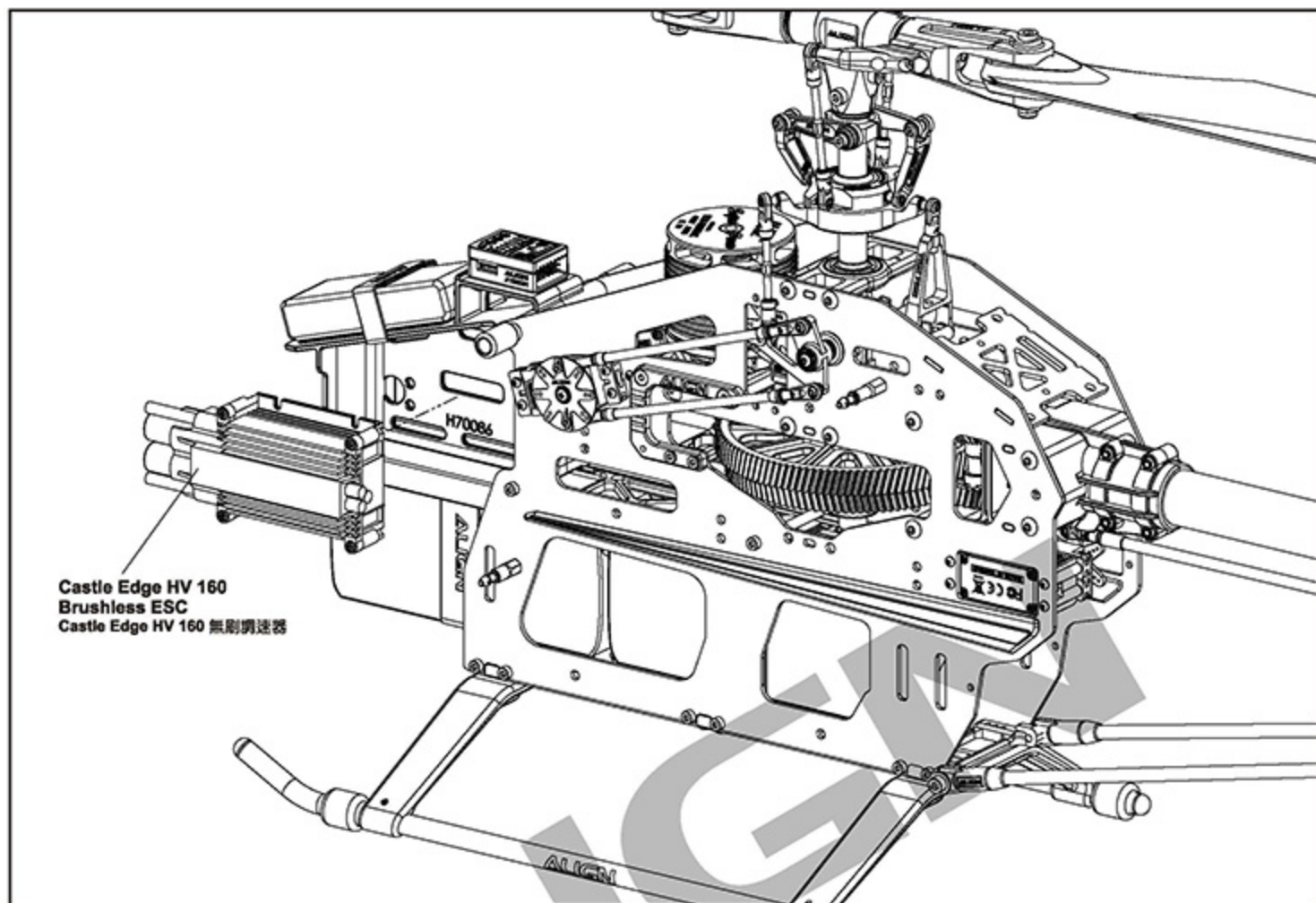

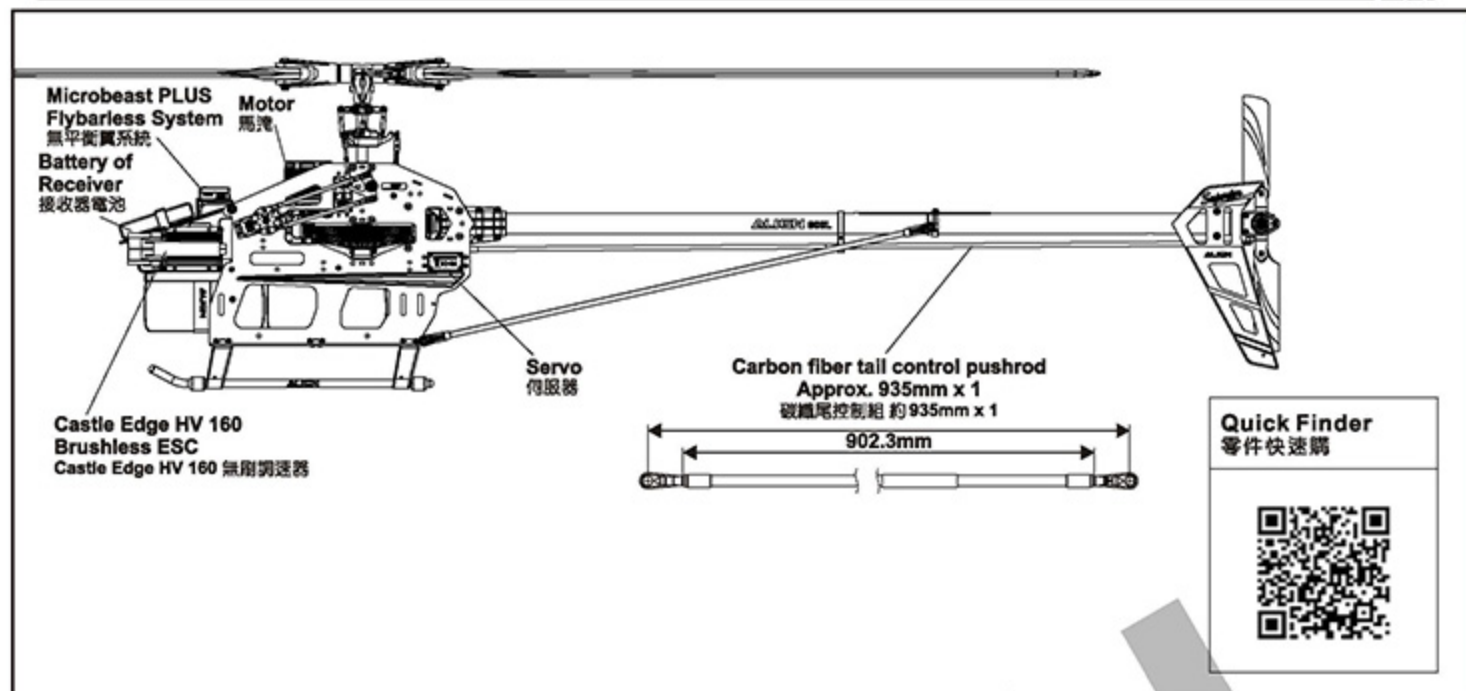

## 13.MICROBEAST PLUS FLYBARLESS MANUAL 無平衡翼系統使用說明

MICROBEAST PLUS Flybarless System as ALIGN helicopter standard equipment, must and compatible with ALIGN standard equipment including blades, servos, motor, battery and so on, please refer to flight and setup instruction in this manual.

ALIGN helicopter 標配使用 MICROBEAST PLUS 無平衡翼系統，須搭配 ALIGN 直昇機標準配件 (主旋翼、伺服器、馬達) 與飛行操作、設定指示。

## USER NOTICE 使用注意事項



1. If assembling and operating the helicopter without using ALIGN standard equipment, including electronic equipment & blades...etc, please make sure there is a sufficiently large and stable power supply to your helicopter. If any abnormal voltage or insufficient power supply, suggest to upgrade the flybarless system to MICROBEAST PLUS HD (Optional) for better power back up.
  2. Please refer to BEASTX MICROBEAST PLUS/HD website for MICROBEAST PLUS/HD assembly and setup instruction.
  3. Any over use, incorrect setup, assembly, modification or misuse will lead to abnormal voltage, electronic devices damage, structural interference, and insufficient power supply. Make sure to carefully check every assembly and setup refer to the manual instruction prior to every flight to prevent any unforeseen danger.
1. 安裝、操控您的直昇機時，如非使用 ALIGN 標準配件 (含電子配件、主旋翼等)，請務必確定您的供電系統有足夠的供電能力，如發現電壓異常、供電不足，建議您升級使用 MICROBEAST PLUS HD 無平衡翼系統 (選配)，以能確保充足、穩定的接收器電源。
  2. MICROBEAST PLUS/HD 使用、設定、接線，請參照 BEASTX MICROBEAST PLUS/HD 官方說明。
  3. 任何電子配件、零件的設定、組裝、修改或操作不良所造成的電壓異常、電子零件損壞，即可能造成供電不穩定等問題，每趟飛行前須注意仔細檢查，防止機件及電子零件故障而引發不可預期的意外。

## MANUAL LINK 設定操作連結

MICROBEAST PLUS Flybarless System is the V4.2 version out of the factory, please feel at ease using it. You can also link to BEASTX MICROBEAST PLUS/HD website to get the latest version and the latest news. And please refer to MICROBEAST PLUS V3.2.x and V4.1.5 instruction manual for operating and setting.

MICROBEAST PLUS 無平衡翼系統，出廠時主程式為 V4.2 版本。您也可以連結至 BEASTX MICROBEAST PLUS/HD 官網查詢，隨時更新最新版本及各項最新訊息。操作設定請同時參照 V3.2.x 版及 V4.2 版使用說明書。



Please visit Align download area to get the completed instruction manual at Align website.

更多詳細的設定操作說明請至官網下載專區下載。  
<http://www.align.com.tw/beastx/>



MICROBEAST PLUS  
BLADES REMOVED SERVOLESS SYSTEM FOR HOBBYISTS

## PARTS IDENTIFICATION 各部位名稱

### MICROBEAST PLUS FLYBARLESS SYSTEM 無平衡翼系統

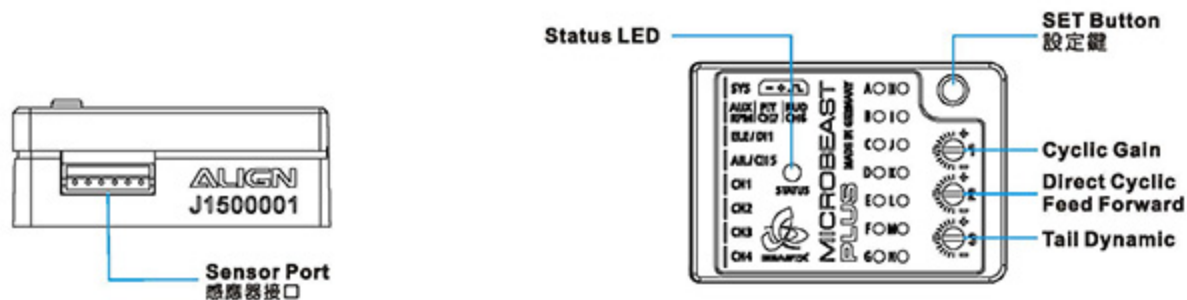

### MICROBEAST PLUS FLYBARLESS SYSTEM WIRING DIAGRAM 無平衡翼系統接線示意圖

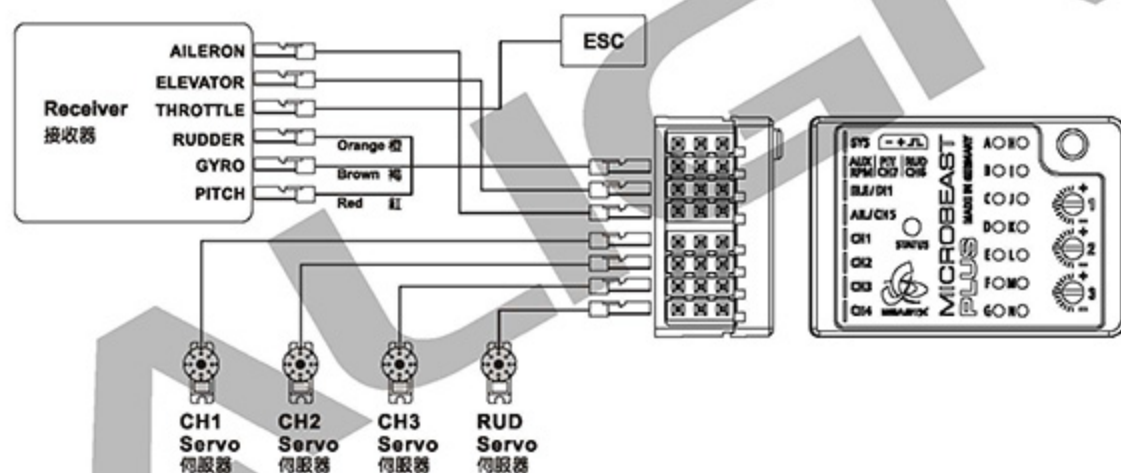

For detail connectivity, please scan QR Code then follow MICROBEAST PLUS manual.

詳細接線方式，請掃描QR Code 連結至MICROBEAST PLUS說明書。



#### MICROBEAST PLUS HD Flybarless System(Optional) MICROBEAST PLUS HD無平衡翼系統(選配)

If assembling and operating the helicopter without using ALIGN standard equipment, including electronic equipment & blades...etc, please make sure there is a sufficiently large and stable power supply to your helicopter. If any abnormal voltage or insufficient power supply, suggest to upgrade the flybarless system to MICROBEAST PLUS HD (Optional) for better power back up. Please refer to BEASTX website for MICROBEAST PLUS HD assembly and setup instruction.

安裝、操控您的直昇機時，如非使用ALIGN標準配件(含電子配件、主旋翼等)，請務必確定您的供電系統有足夠的供電能力，如發現電壓異常、供電不足，建議您升級使用MICROBEAST PLUS HD無平衡翼系統(選配)，以能確保充足、穩定的接收器電源。MICROBEAST PLUS HD使用、設定、接線，請參照MICROBEAST PLUS HD官方說明。



To set this option is to turn on the transmitter and connect to BEC power.

**Note:** For the safety, please do not connect ESC to the brushless motor before the setting in order to prevent any accident caused by the motor running during the setting.

此項設定只要開啟發射器，接上BEC電源即可進行操作。

注意：為了安全起見，設定前請先不要將無刷調速器與無刷馬達三條線接上，以免調整時啟動馬達而發生危險。

### SERVO CONFIGURATION 伺服器配置

Following the servo configuration diagram on right, plug the servos to Gyro.

請依照右圖圖示的伺服器名稱，將伺服器接到陀螺儀。

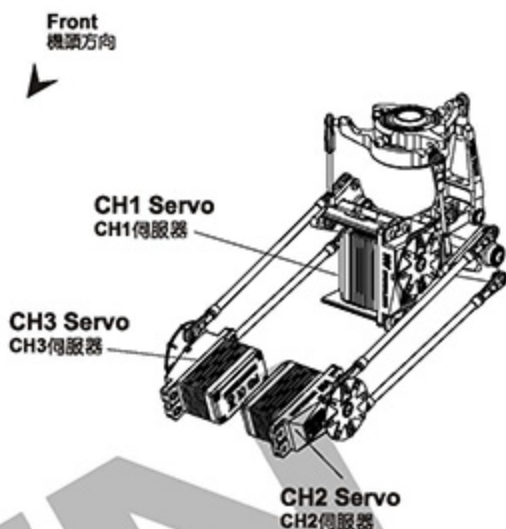

### 15.ADJUSTMENTS FOR GYRO AND TAIL NEUTRAL SETTING 陀螺儀與尾翼中立點設定調整

Turn off Revolution mixing (RVMX) mode on the transmitter, then set the gain switch on the transmitter and the gyro to non-head lock mode, or disable gain completely. After setting the transmitter, connect the helicopter power and proceed with rudder neutral point setting. **Note:** When connecting to the helicopter power, please do not touch tail rudder stick and the helicopter, wait for 3 seconds for gyro to enable, and the rudder servo horn should be 90 degrees to the tail servo. Tail pitch slider should be half way on the tail output shaft. This will be the standard rudder neutral point. After completing this setting, set the gain switch back to heading lock mode, with gain at around 70%.

發射器內陀螺儀設定請關閉根輪混控模式，並將發射器上的感度開關與陀螺儀切至“非鎖定模式”或將陀螺儀感度關閉。發射器設定完成後接上直昇機電源，即可進行尾舵中立點設定。注意：當接上直昇機電源時請勿動尾舵搖桿或碰觸機體，待3秒陀螺儀開機完成後，尾舵伺服臂需與尾伺服器約成90度，尾旋翼控制組須正確置於尾橫軸約中間位置，即為標準尾舵中立點設定，設定完成後，切換至“鎖定模式”，感度設約70%左右。

### TAIL NEUTRAL SETTING 尾中立點設定

After the gyro is enable and under non-head lock mode, correct setting position of tail servo and tail pitch assembly is as photo. If the tail pitch assembly is not in the middle position, please adjust the length of rudder control rod to trim.

陀螺儀開機後，在非鎖定模式下，尾伺服器與尾 Pitch 控制組正確擺置位置。若尾 Pitch 控制組未置中時請調整尾控制連桿的長度來修正。

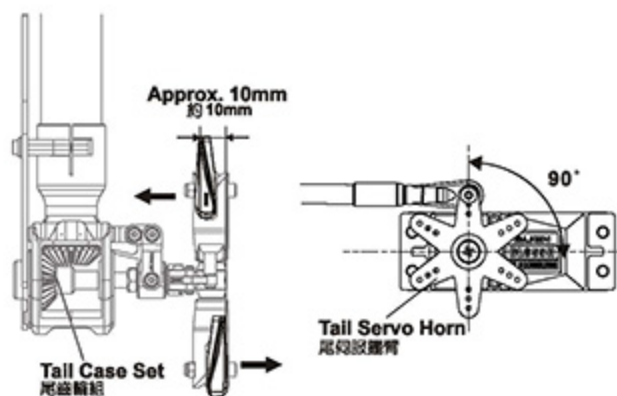

### HEAD LOCK DIRECTION SETTING OF GYRO 陀螺儀鎖定方向設定

To check the head lock direction of gyro is to move the tail clockwise and the tail servo horn will be trimmed counterclockwise. If it trims in the reverse direction, please switch the gyro to "REVERSE".

陀螺儀鎖定方向確認，當手搖尾部順時鐘擺動，尾舵伺服臂應反時鐘修正，反向時請切換陀螺儀上“鎖定反向”開關修正。

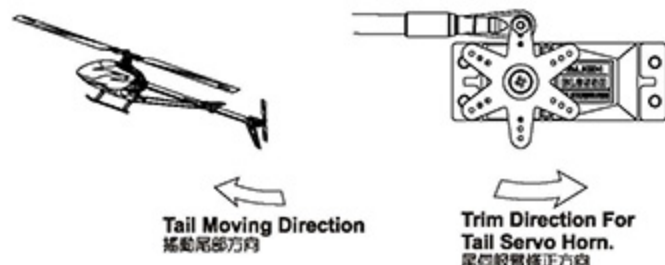

GENERAL FLIGHT 一般飛行模式



Stick Position at High/Throttle 100%/Pitch+12°  
搖桿高速/油門100%/Pitch+12°



Stick Position at Hovering/Throttle 70%/Pitch+5°  
搖桿停懸/油門70%/Pitch+5°



Stick Position at Low/Throttle 0%/Pitch 0°~-2°  
搖桿低速/油門0%/Pitch 0°~-2°

3D FLIGHT 3D特技飛行模式

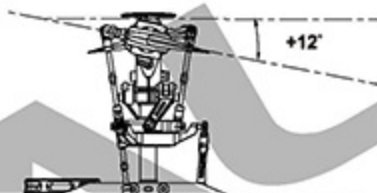

Stick Position at High/Throttle 100%/Pitch+12°  
搖桿高速/油門100%/Pitch+12°

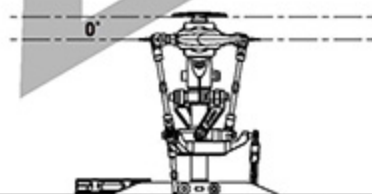

Stick Position at Middle/Throttle 90%/Pitch 0°  
搖桿中速/油門90%/Pitch 0°

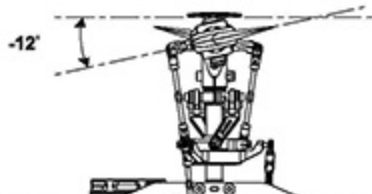

Stick Position at Low/Throttle 100%/Pitch-12°  
搖桿低速/油門100%/Pitch-12°



1. Pitch range : Approx.  $\pm 15$  degrees.
  2. If the pitch is set too high, it will result in shorter flight duration and poor motor performance.
  3. Setting the throttle to provide a higher speed is preferable to increasing the pitch too high.
1. 螺距 (Pitch) 總行程約  $\pm 15$
2. 過大螺距設定，會導致動力與飛行時間降低。
3. 動力提升以較高轉速的設定方式，優於螺距調大的設定。

GENERAL FLIGHT 一般飛行模式

Throttle 油門	Pitch 螺距
5 100% High Speed 100% 高速	+12°
4 85%	
3 60%~65% Hovering 60%~65% 停懸	+12°
2 40%	
1 0% Low Speed 0% 低速	0°~-2°

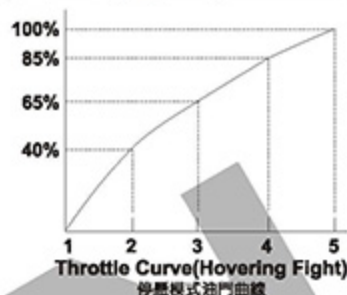

PITCH AND ROTATION SPEED PITCH與轉速關係

TIP: It is recommended to use a lower pitch setting when using higher RPM Head speed. This will allow for better power. 搭配要領：如果使用較高轉速馬達動力建議搭配調低 Pitch，將獲得較佳動力效能。

IDLE 1: SPORT FLIGHT

Throttle 油門	Pitch 螺距
5 100%	+10°~+12°
4 75%	
3 70%	+5°
2 75%	
1 80%	-5°

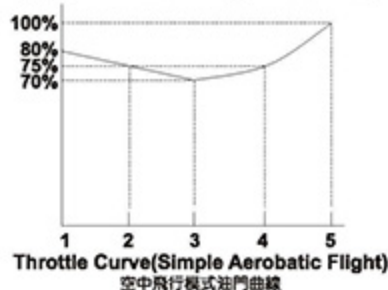

IDLE 2: 3D FLIGHT

Throttle 油門	Pitch 螺距
5 100% High 100% 高	+12°
3 85% Middle 85% 中	0°
1 100% Low 100% 低	-12°

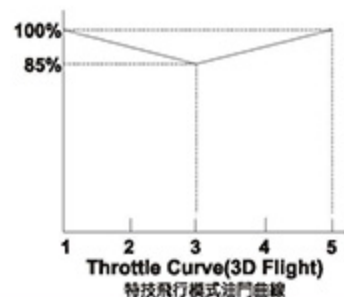

**RCM-BL850MX MOTOR RCM-BL850MX 無刷馬達**

Power and torque requirements of enthusiasts, the high output 850MX motor was born in Align's R&D lab. With dramatic increase in torque and power output, capable of 5100 watts continuous power output and 11000 watts of burst power!

850MX Motor has passed various thorough inspections made by our technical department, including motive testing, static testing, magnetic field testing, heat resistance and magnetic loss testing, running balance and vibration testing, noise testing, and many hours of actual loading and flying testing, etc. Align is proud to provide the latest innovations in RC Modeling to its consumers. Please enjoy your Align products safely.

亞拓特別針對玩家大動力、高扭力的需求，研發設計出為極致動力而生的 850MX 馬達，動力輸出與扭力表現大幅提升，持續輸出功率達 5100W，瞬間最大輸出功率可達 11000W。本公司生產的高扭力高轉速 850MX 馬達，適用於 RC 電動商品，其高功率高效率輸出特性，適合電動飛機 / 電動直昇機之高扭力高轉速驅動動力用途，速度控制可採本公司或市售規格無刷電子變速器。轉子採用高磁性材料鈹鐵精製而成，定子採用本廠 NC 自動繞線與高強度樹脂成型保護，耐高溫低震動。心軸採高硬度高鋼性軸承鋼及雙 ZZ 高速精密軸承設計，且經由亞拓獨立開發設計技術，使用壽命長、效率高、耐撞不易變形、低磁損、高效能 850 型無刷馬達。該項新商品已通過本廠技術單位，實施精密嚴格動、靜態、磁場特性、強磁耐高溫磁損、運轉平衡震動及噪音、負載實測飛行動態性能等全項嚴格檢測。

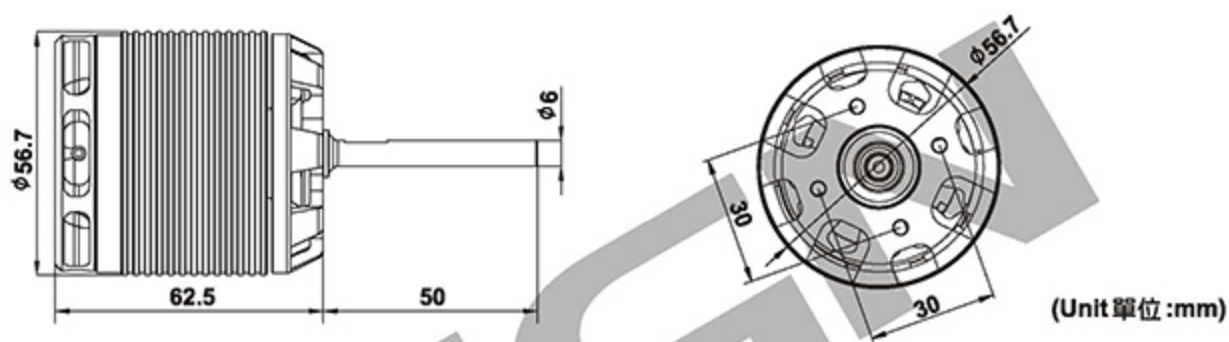
**SPECIFICATION 尺寸規格**

<b>KV</b>	<b>KV 值</b>	490KV(RPM/V)	<b>Input Voltage</b>	<b>輸入電壓</b>	12S
<b>Stator Diameter</b>	<b>定子外徑</b>	45 mm	<b>Stator Thickness</b>	<b>定子高度</b>	35mm
<b>Stator Arms</b>	<b>矽鋼片槽數</b>	12	<b>Magnet Poles</b>	<b>磁極數</b>	10
<b>Max Continuous Current</b>	<b>最大持續電流</b>	115A	<b>Max Instantaneous Current</b>	<b>最大瞬間電流</b>	250A(2sec)
<b>Max Continuous Power</b>	<b>最大持續功率</b>	5100W	<b>Max Instantaneous Power</b>	<b>最大瞬間功率</b>	11000W(2sec)
<b>Dimension</b>	<b>尺寸</b>	Shaft $\phi$ 6x56.7x112.5mm	<b>Weight</b>	<b>重量</b>	Approx. 570g

**ILLUSTRATION 接線示意圖**

The motor rotates in different direction with different brand ESCs. If the wrong rotating direction happens, please switch any two cables to make the motor rotates in right direction.

由於各品牌電子變速器的馬達啟動轉向不盡相同，若發生轉向錯誤時，請將馬達與電子變速器的接線任兩條對調即可。

## PLEASE PRACTICE SIMULATION FLIGHT BEFORE REAL FLYING 飛行前請先熟練電腦模擬飛行

A safe and effective practice method is to use the transmitter flying on the computer through simulator software sold on the market. Do a simulation flight until you familiarize your fingers with the movements of the rudders, and keep practicing until the fingers move naturally.

1. Place the helicopter in a clear open field ( Make sure the power OFF ) and the tail of helicopter point to yourself.
2. Practice to operate the throttle stick (as below illustration) and repeat practicing "Throttle high/low", "Aileron left/right", "Rudder left/right", and "Elevator up/down".
3. The simulation flight practice is very important, please keep practicing until the fingers move naturally when you hear operation orders being call out.

在還沒瞭解直昇機各動作的操控方式前，嚴禁實機飛行，請先進行電腦模擬飛行的練習，一種最有效、最安全的練習方式，就是透過市面販售的模擬軟體，以遙控器在電腦上模擬飛行，熟悉各種方向的操控，並不斷的重複，直到手指可熟練的控制各個動作及方向。

1. 將直昇機放在空曠的地方(確認電源為關閉)，並將直昇機的機尾對準自己。
2. 練習操作遙控器的各搖桿(各動作的操作方式如下圖)，並反覆練習油門高/低、副翼左/右、升降舵前/後及方向舵左/右操作方式。
3. 模擬飛行的練習相當重要，請重複練習直到不需思索，手指能自然隨著喊出的指令移動控制。



Mode 1	Mode 2	Illustration 圖示
Aileron 副翼		<ul style="list-style-type: none"> <li>Move Left 左移</li> <li>Move Right 右移</li> <li>Rotate Left 左翻</li> <li>Rotate Right 右翻</li> </ul>
Elevator 升降/前後		<ul style="list-style-type: none"> <li>Fly Forward 前進</li> <li>Fly Backward 後退</li> <li>Forward Rotate 前翻</li> <li>Backward Rotate 後翻</li> </ul>
Throttle 油門		<ul style="list-style-type: none"> <li>Ascent 上升</li> <li>Descent 下降</li> </ul>
Rudder 方向		<ul style="list-style-type: none"> <li>Turn Right 右旋</li> <li>Turn Left 左旋</li> </ul>

## FLIGHT ADJUSTMENT AND NOTICE 飛行調整與注意



- ⊙ Check if the screws are firmly tightened.
- ⊙ Check if the transmitter and receivers are fully charged.
- ⊙ 再次確認→螺絲是否鎖固?
- ⊙ 發射器和接收器電池是否足夠。



If there are other radio control aircraft at the field, make sure to check their frequencies and tell them what frequency you are using. Frequency interference can cause your model, or other models to crash and increase the risk of danger. 假使飛行場有其他遙控飛機，請確認他們的頻率，並告知他們您正在使用的頻率，相同的頻率會造成干擾導致失控和大大地增加風險。

## STARTING AND STOPPING THE MOTOR 啟動和停止馬達



First check to make sure no one else is operating on the same frequency. Then place the throttle stick at lowest position and turn on the transmitter. 首先確認附近沒有其他相同頻率的使用，然後打開發射器將油門搖桿推到最低點。

- Check the movement.
- 動作確認



**ONI Step1**  
First turn on the transmitter.  
先開啟發射器



**ONI Step2**  
Connect to the helicopter power  
接上直昇機電源



Check if the throttle stick is set at the lowest position. 確認油門搖桿是在最低的位置。

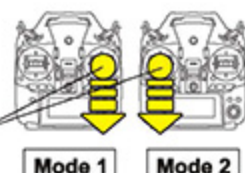

- ⊙ Are the rudders moving according to the controls?
- ⊙ Follow the transmitter's instruction manual to do a range test.
- ⊙ 方向舵是否隨著控制方向移動?
- ⊙ 根據發射器說明書進行距離測試。



**OFF! Step3**  
Reverse the above orders to turn off.  
關閉電源時請依上述操作動作反執行。

This procedure is best performed on soft surfaces such as grass. The use of rubber skid stopper is recommended on hard surface to prevent vibration feedback from the ground to Gyro, resulting in over-corrections.

將直升機置於柔軟地面上，建議硬地起飛腳架裝上避震墊圈。避免升空前腳架與過硬的地面震動太大反饋至機身上的Gyro，影響無平衡翼系統升空前過度修正。

Rubber skid stoppers  
installed  
裝上避震墊圈



CAUTION  
注意

If swashplate should tilt prior to lift off, do not try to manually trim the swashplate level. This is due to vibration feedback to the Gyro, and will disappear once helicopter lifts off the ground. If manual trim is applied, helicopter will tilt immediately after liftoff.

直昇機離地前，十字盤可能因Gyro受震動的回饋，使十字盤有傾斜的情形，此時請勿刻意將十字盤修正為水平狀態，此現象只要離地升空時立即解除，可平穩升空；若刻意將十字盤修正為水平時，反而會造成感應器過度修正，一離地即偏往修正方向的危險。

## MAIN ROTOR ADJUSTMENTS 主旋翼雙槳平衡調整

1. Before adjusting, apply a red piece of tape on one blade, or paint a red stripe with a marker or paint to identify on blade.
2. Raise the throttle stick slowly and stop just before the helicopter lifts-off ground. Look at the spinning blades from the side of the helicopter.
3. Look at the path of the rotor carefully. If the two blades rotate in the same path, it does not need to adjustment. If one blade is higher or lower than the other blade, adjust the tracking immediately.

1. 調整前先在其中一支主旋翼的翼端，貼上有顏色的貼紙或畫上顏色記號，方便雙槳調整辨識。

2. 慢慢的推起油門搖桿到高點並且停止，在飛機離地前，從飛機側邊觀察主旋翼轉動。

3. 仔細觀察旋翼軌跡(假如兩支旋翼移動都是相同軌跡，則不需要調整；可是如果一支旋翼較高或較低產生“雙槳”的情形時，則必須立刻調整軌跡)。

- a. When rotating, the blade with higher path means the pitch is too big. Please shorten DFC ball link for regular trim.
- b. When rotating, the blade with lower path means the pitch too is small. Please lengthen DFC ball link for regular trim.

a. 旋翼轉動時較高軌跡的主旋翼表示螺距(PITCH)過大，請調短DFC連桿修正。

b. 旋翼轉動時較低軌跡的主旋翼表示螺距(PITCH)過小，請調長DFC連桿修正。

CAUTION  
注意

Tracking adjustment is very dangerous, so please keep away from the helicopter at a distance of at least 10m.

調整軌跡非常危險，請於距離飛機最少10公尺的距離。

Incorrect tracking may cause vibrations. Please repeat adjusting the tracking to make sure the rotor is correctly aligned. After tracking adjustment, please check the pitch angle is approx.  $+5\sim 6^\circ$  when hovering.

不正確的旋翼軌跡會導致震動，請不斷重複調整軌跡，使旋翼軌跡精準正確。

在調整軌跡後，確認一下Pitch角度在停旋時應為大約 $+5\sim 6^\circ$ 。

Color Mark 有標示記號的主旋翼



## FLIGHT ADJUSTMENT AND NOTICE 飛行調整與注意

FORBIDDEN  
禁止



Do not attempt to grab or make contact with the helicopter while the main blades are in motion and keep your eyes away from the helicopter. During take-off, landing, and flight, be sure to keep the helicopter away from all obstacles. Operators must stand at least 10 meters away from the helicopter to avoid injury caused by loose parts due to improper assembly or any unforeseen dangers.

嚴禁用手抓取運行中的直昇機，並禁止將直昇機對準眼睛，當主旋翼轉動後，或起飛/試飛時，務必遠離障礙物，站立位置必需距離10公尺以上，避免因人為組裝不當造成零件脫落，而引發不可預期的財物及人員損傷。

CAUTION  
注意

Make sure that no one or obstructions in the vicinity.

For flying safety, please carefully check if every movement and directions are correct when hovering.

確認鄰近地區沒有人和障礙物。

為了飛行安全，您必須先確認停懸時各項操控動作是否正確。

CAUTION  
注意

Do not attempt to fly until you have some experiences with the operation of helicopter.

嚴禁無熟練操控飛行經驗者操控飛行。

## STEP 1 THROTTLE CONTROL PRACTICE 油門控制練習

- When the helicopter begins to lift-off the ground, slowly reduce the throttle to bring the helicopter back down. Keep practicing this action until you control the throttle smoothly.

當直昇機開始離地時，慢慢降低油門將飛機降下。持續練習飛機從地面上升和下降直到您覺得油門控制很順。

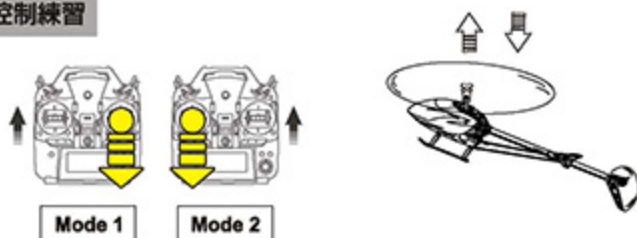

## STEP 2 AILERON AND ELEVATOR CONTROL PRACTICE 副翼和升降控制練習

- Raise the throttle stick slowly.
- Move the helicopter in any direction back, forward, left and right, slowly move the aileron and elevator sticks in the opposite direction to fly back to its original position.

- 慢慢升起油門搖桿。
- 使直昇機依指示：移動向後/向前/向左/向右，慢慢的反向移動副翼和升降搖桿並將直昇機開回到原來位置。

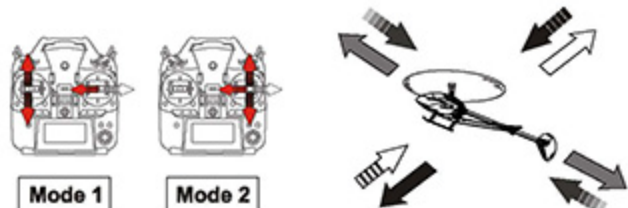

- If the nose of the helicopter moves, please lower the throttle stick and land the helicopter. Then move your position diagonally behind the helicopter 10M and continue practicing.
- If the helicopter flies too far away from you, please land the helicopter and move your position behind 10M and continue practicing.
- 當直昇機機頭偏移時，請降低油門並且降落，然後移動自己的位置到直昇機的正後方10公尺再繼續練習。
- 假如直昇機飛離你太遠，請先降落直昇機，並到直昇機後10公尺再繼續練習。

## STEP 3 RUDDER CONTROL PRACTICING 方向舵操作練習

- Slowly raise the throttle stick.
- Move the nose of the helicopter to right or left, and then slowly move the rudder stick in the opposite direction to fly back to its original position.

- 慢慢升起油門搖桿。
- 將直昇機機頭移動左或右，然後慢慢反向移動方向舵搖桿並將直昇機飛回原本位置。

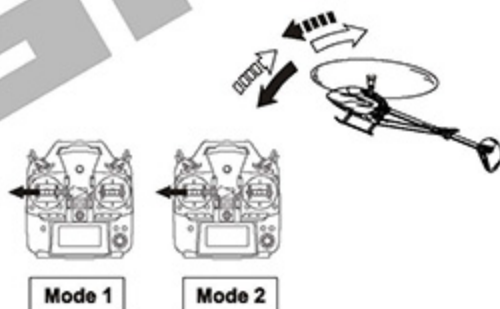

## STEP 4

After you are familiar with all actions from STEP1 to 3, draw a circle on the ground and practice within the circle to increase your accuracy.

當你覺得 STEP1~3 動作熟悉了，在地上畫個圈並在這個圈圈的範圍內練習飛行，以增加你操控的準確度。

- You can draw a smaller circle when you get more familiar with the actions.
- 當你更加習慣操作動作，你可以畫更小的圈。



## STEP 5 DIRECTION CHANGE AND HOVERING PRACTICE 改變直昇機方向和練習停旋

After you are familiar with STEP1 to 4, stand at side of the helicopter and continue practicing STEP1 to 4. Then repeat the STEP1 to 4 by standing right in front of the helicopter.

當你覺得STEP1~4動作熟悉了，站在面對直昇機側邊並繼續練習STEP1~4。之後，站在直昇機機頭右邊重複步驟練習。

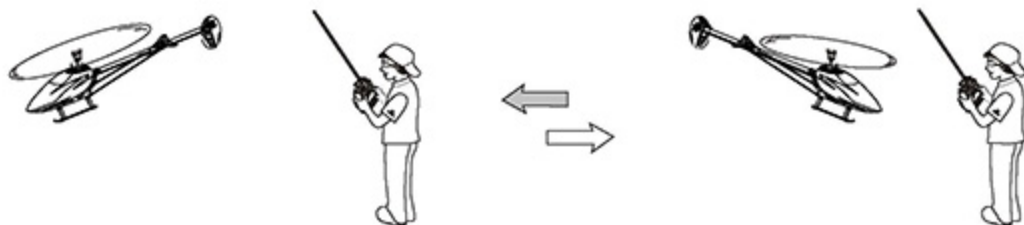

	Problem 狀況	Cause 原因	Solution 對策
Blade Tracking 雙槳平衡	Tracking is Off 雙槳	Pitch linkage rods are not even length PITCH連桿長度調整不平均	Adjust length of DFC ball link. 調整DFC連桿頭長度
Hover 停懸	Head speed too low 主旋翼轉速偏低	Excessive pitch 主旋翼的PITCH偏高	Adjust DFC ball link to reduce pitch by 4 to 5 degrees. 調整DFC連桿頭調低Pitch約+4-5度
		Hovering throttle curve is too low 停懸點油門曲線過低	Increase throttle curve at hovering point on transmitter (around 60%) 調高停懸點油門曲線(約60%)
	Head speed too high 主旋翼轉速偏高	Not enough pitch 主旋翼的PITCH偏低	Adjust DFC ball link to increase pitch by 4 to 5 degrees. 調整DFC連桿頭調高Pitch約+4-5度
		Hovering throttle curve is too high 停懸點油門曲線過高	Decrease throttle curve at hovering point on transmitter (around 60%) 調低停懸點油門曲線(約60%)
Rudder Response 尾舵反應	Drifting of tail occurs during hovering, or delay of rudder response when centering rudder stick. 停懸時尾翼向某一邊偏移，或撥動方向舵並回復到中立點時，尾翼產生延遲，無法停頓在所控制位置上。	Rudder neutral point improperly set 尾中立點設定不當	Reset rudder neutral point 重設尾中立點
	Tail oscillates (hunting, or wags) at hover or full throttle 停懸或全油門時尾翼左右來回搖擺。	Rudder gyro gain too low 尾舵陀螺儀感度偏低	Increase rudder gyro gain 增加尾舵陀螺儀感度
		Rudder gyro gain too high 尾舵陀螺儀感度偏高	Reduce rudder gyro gain 降低尾舵陀螺儀感度

If above solution does not resolve your issues, please check with experienced pilots or contact your Align dealer.

※在做完以上調整後，仍然無法改善情況時，應立即停止飛行並向有經驗的飛手諮詢或連絡您的經銷商。

Thank you for purchasing and supporting ALIGN products.

The Align Team is dedicated to you by innovating and developing new RC Helicopters, Multicopters, and FPV Racing Quads. We strive to provide a more diversified experience for our customers. Visit our website at [www.align.com.tw](http://www.align.com.tw) for latest news, information, and updates about our extensive line of products for the RC enthusiasts.

Good Flying!

再次感謝您對亞拓系列商品的喜愛與支持，您的肯定是對我們最大的認同。

亞拓團隊秉持創新研發的精神，開發遙控直昇機／多軸飛行機／穿越機系列商品，提供給您體驗更多樣化的飛行樂趣。您可以透過下列連結，隨時瞭解亞拓的最新動態，以及各項訊息分享。

祝福您有一個愉快的飛行體驗。



**ALIGN Flight Safety 亞拓飛行安全宣導**  
<http://www.align.com.tw/flysafe-en/>



**ALIGN T-REX Helicopter 亞拓遙控直昇機**  
<http://www.align.com.tw/helicopter-en/>



**ALIGN Multicopter 亞拓多軸飛行機**  
<http://www.align.com.tw/multicopter-en/>



**ALIGN FPV Racing Quad 亞拓穿越機**  
<http://www.align.com.tw/multicopter-en/mr25/>



**ALIGN Website 亞拓官網**  
<http://www.align.com.tw>



**ALIGN Shopping Cart 亞拓購物車**  
<http://shop.align.com.tw/index.php?language=en>



**ALIGN Quick Finder 亞拓零件快速購**  
<http://shop.align.com.tw/partfinder.php?language=en>



**ALIGN FaceBook**  
<https://www.facebook.com/Align-Corporation-194493419543/?ref=mf>



**ALIGN Instagram**  
<https://instagram.com/aligncorporation/>



**ALIGN YouTube**  
[https://www.youtube.com/channel/UCaPj\\_K5DNo7HSmP1eytUvMQ](https://www.youtube.com/channel/UCaPj_K5DNo7HSmP1eytUvMQ)



**ALIGN Youku**  
<http://i.youku.com/u/UMTQ0NjEwNjcZNg==>

**ALIGN**





# ALIGN

## Specifications & Equipment/規格配備:

Length/機身長:1478mm

Height/機身高:393mm

Main Blade Length/主旋翼長:780mm

Main Rotor Diameter/主旋翼直徑:1740mm

Tail Rotor Diameter/尾旋翼直徑:301mm

Motor Drive Gear/馬達齒輪:12T

Main Drive Gear/主齒輪:112T

Autorotation Tail Drive Gear/尾驅動主齒:104T

Tail Drive Gear/尾翼傳動齒:24T

Drive Gear Ratio/齒輪傳動比:9.33 : 1 : 4.73

Flying Weight(Without battery)/全配重(不含電池):Approx. 3950g

