

# Super Combo T-REX 700E V3

# ALIGN

## INSTRUCTION MANUAL

## 使用說明書

RH70E08XT

# F3C

Performance Redefined

### Contents

1	INTRODUCTION 前言
1~2	SAFETY NOTES 安全注意事項
3	EQUIPMENT REQUIRED FOR ASSEMBLY 自備設備
3	PACKAGE ILLUSTRATION 包裝說明
4	SAFETY CHECK BEFORE FLYING 飛行前安全檢查重要事項
5~19	ASSEMBLY SECTION 組裝說明
20	EQUIPMENT INSTALLATION 各項設備配置圖
21	BATTERY INSTALLATION ILLUSTRATION 電池安裝示意圖
22	INSTALLATION FOR ESC AND BEC 無刷調速器與BEC安裝
22	CANOPY ASSEMBLY 機頭罩安裝
23	ELECTRIC EQUIPMENT ILLUSTRATION 電子設備建議配置圖示
24	SERVO SETTING AND ADJUSTMENT 伺服器設定調整
24	ADJUSTMENTS FOR GYRO AND TAIL NEUTRAL SETTING 陀螺儀與尾翼中立點調整
25	PITCH AND THROTTLE SETTING 主旋翼螺距與油門設定
26	6A EXTERNAL BEC INSTRUCTION MANUAL 6A外接式BEC使用說明
27~33	GP900 HEAD LOCK GYRO SET USER MANUAL GP900鎖定式陀螺儀組使用說明
33	RCM-BL750MX 450KV POWER COLLOCATION REFERENCE 原裝動力數據參考表
34~36	FLIGHT ADJUSTMENT AND SETTING 飛行動作調整與設定



Thank you for buying ALIGN products. The T-REX 700E F3C V3 is the latest technology in Rotary RC models. Please read this manual carefully before assembling and flying the new T-REX 700E F3C V3 helicopter. We recommend that you keep this manual for future reference regarding tuning and maintenance.

承蒙閣下選用亞拓遙控世界系列產品，謹表謝意。進入遙控世界之前必須告訴您許多相關的知識與注意事項，以確保您能夠在學習的過程中較得心應手。在開始操作之前，請務必詳閱本說明書，相信一定能夠給您帶來相當大的幫助，也請您妥善保管這本說明書，以作為日後參考。

Thank you for buying ALIGN Products. The T-REX 700E F3C V3 Helicopter is designed as an easy to use, full featured Helicopter R/C model capable of all forms of rotary flight. Please read the manual carefully before assembling the model, and follow all precautions and recommendations located within the manual. Be sure to retain the manual for future reference, routine maintenance, and tuning. The T-REX 700E F3C V3 is a new product developed by ALIGN. It features the best design available on the R/C helicopters market to date, providing flying stability for beginners, full aerobatic capability for advanced fliers, and unsurpassed reliability for customer support.

感謝您選購亞拓產品，為了讓您容易方便的使用 T-REX 700E F3C V3 直昇機、請您詳細的閱讀完這本說明書之後再進行組裝以及操作這台直昇機，同時請您妥善的保存這本說明書、作為日後進行調整以及維修的參考。T-REX 700E F3C V3 是由亞拓自行研發的新產品，不論是需求飛行穩定性的初學者或是追求性能的飛行愛好者，T-REX 700E F3C V3 將是您最佳的選擇。

### WARNING LABEL LEGEND 標誌代表涵義

 FORBIDDEN 禁止	<b>Do not attempt under any circumstances.</b> 在任何禁止的環境下，請勿嘗試操作。
 WARNING 警告	<b>Mishandling due to failure to follow these instructions may result in damage or injury.</b> 因為疏忽這些操作說明，而使用錯誤可能造成財產損失或嚴重傷害。
 CAUTION 注意	<b>Mishandling due to failure to follow these instructions may result in danger.</b> 因為疏忽這些操作說明，而使用錯誤可能造成危險。

### IMPORTANT NOTES 重要聲明

R/C helicopters, including the T-REX 700E F3C V3 are not toys. R/C helicopter utilize various high-tech products and technologies to provide superior performance. Improper use of this product can result in serious injury or even death. Please read this manual carefully before using and make sure to be conscious of your own personal safety and the safety of others and your environment when operating all ALIGN products. Manufacturer and seller assume no liability for the operation or the use of this product. This product is intended for use only by adults with experience flying remote control helicopters at a legal flying field. After the sale of this product we cannot maintain any control over its operation or usage.

As the user of this product, you are solely responsible for operating it in a manner that does not endanger yourself and others or result in damage to the product or the property of others.

T-REX 700E F3C V3 遙控直昇機並非玩具，它是結合了許多高科技產品所設計出來的休閒用品，所以商品的使用不當或不熟悉都可能會造成嚴重傷害甚至死亡，使用之前請務必詳讀本說明書，勿輕忽並注意自身安全。注意！任何遙控直昇機的使用，製造商和經銷商是無法對使用者於零件使用的損耗異常或組裝不當所發生之意外負任何責任，本產品是提供給有操作過模型直昇機經驗的成人或有相當技術的人員在旁指導於當地合法遙控飛行場飛行，以確保安全無虞下操作使用，產品售出後本公司將不負任何操作和使用控制上的任何性能與安全責任。

做為本產品的使用者，您，是唯一對於您自己操作的環境及行為負全部的責任之人。

We recommend that you obtain the assistance of an experienced pilot before attempting to fly our products for the first time. A local expert is the best way to properly assemble, setup, and fly your model for the first time. The T-REX 700E F3C V3 requires a certain degree of skill to operate, and is a consumer item. Any damage or dissatisfaction as a result of accidents or modifications are not covered by any warranty and cannot be returned for repair or replacement. Please contact our distributors for free technical consultation and parts at discounted rates when you experience problems during operation or maintenance. As Align Corporation Limited has no control over use, setup, final assembly, modification or misuse, no liability shall be assumed nor accepted for any resulting damage or injury. By the act of use, setup or assembly, the user accepts all resulting liability.

模型商品屬於需高操作技術且為消耗性之商品，如經拆裝使用後，會造成不等情況零件損耗，任何使用情況所造成商品不良或不滿意，將無法於保固條件內更換新品或退貨，如遇有使用操作維修問題，本公司全省分公司或代理商將提供技術指導、特價零件供應服務。對使用者的不當使用、設定、組裝、修改、或操作不良所造成的破壞或傷害，本公司無法控制及負責。任何使用、設定、組裝、修改、或操作不良所造成的破壞、意外或傷害，使用者應承擔全部責任。

### 2.SAFETY NOTES 安全注意事項

 CAUTION 注意	<ul style="list-style-type: none"> <li>· Fly only in safe areas, away from other people. Do not operate R/C aircraft within the vicinity of homes or crowds of people. R/C aircraft are prone to accidents, failures, and crashes due to a variety of reasons including, lack of maintenance, pilot error, and radio interference. Pilots are responsible for their actions and damage or injury occurring during the operation or as a result of R/C aircraft models.</li> <li>· Prior to every flight, carefully check rotorhead spindle shaft screws and tail blade grip screws, linkage balls and screws, ensure they are firmly secured.</li> <li>· 遙控模型飛機、直昇機屬高危險性商品，飛行時務必遠離人群，人為組裝不當或機件損壞、電子控制設備不良，以及操控上的不熟悉、都有可能導致飛行失控損傷等不可預期的意外，請飛行者務必注意飛行安全，並需了解自負疏忽所造成任何意外之責任。</li> <li>· 每趟飛行前須仔細檢查，主旋翼夾座橫軸螺絲、尾旋翼夾座螺絲，以及機身各部位球頭、螺絲，確實上膠鎖緊才能昇空飛行。</li> </ul>
--	---



## LOCATE AN APPROPRIATE LOCATION 遠離障礙物及人群

R/C helicopters fly at high speed, thus posing a certain degree of potential danger. Choose a legal flying field consisting of flat, smooth ground without obstacles. Do not fly near buildings, high voltage cables, or trees to ensure the safety of yourself, others and your model. For the first practice, please choose a legal flying field. Do not fly your model in inclement weather, such as rain, wind, snow or darkness.

直昇機飛行時具有一定的速度，相對的也潛在著危險性，場地的選擇也相對的重要，請需遵守當地法規到合法遙控飛行場地飛行。務必選擇在空曠合法專屬飛行場地，並必須注意周邊有沒有人、高樓、建築物、高壓電線、樹木等等，避免操控的不當造成自己與他人財產的損壞。  
請勿在下雨、打雷等惡劣氣候下操作，以確保本身及機體的安全。



## NOTE ON LITHIUM POLYMER BATTERIES 鋰聚電池注意事項

Lithium Polymer batteries are significantly more volatile than alkaline or Ni-Cd/Ni-MH batteries used in RC applications. All manufacturer's instructions and warnings must be followed closely. Mishandling of Li-Po batteries can result in fire. Always follow the manufacturer's instructions when disposing of Lithium Polymer batteries.

鋰聚電池跟一般在RC使用的鹼性電池、鎳鎘電池、鎳氫電池比較起來是相對危險的。請嚴格遵守鋰聚電池說明書之使用注意事項。不恰當使用鋰聚電池，可能造成火災並危及生命財產安全，切勿大意！

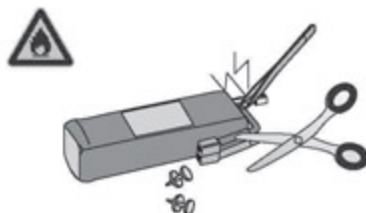

## PREVENT MOISTURE 遠離潮濕環境

R/C models are composed of many precision electrical components. It is critical to keep the model and associated equipment away from moisture and other contaminants. The introduction or exposure to water or moisture in any form can cause the model to malfunction resulting in loss of use, or a crash. Do not operate or expose to rain or moisture.

直昇機內部也是由許多精密的電子零組件組成，所以必須絕對的防止潮濕或水氣，避免在浴室或雨天時使用，防止水氣進入機身內部而導致機件及電子零件故障而引發不可預期的意外！



## PROPER OPERATION 勿不當使用本產品

Please use the replacement of parts on the manual to ensure the safety of instructors. This product is for R/C model, so do not use for other purpose.

請勿自行改造加工，任何的升級改裝或維修，請使用亞拓產品目錄中的零件，以確保結構的安全。請確認於產品限界內操作，請勿過載使用，並勿用於安全、法令外其它非法用途。



## OBTAIN THE ASSISTANCE OF AN EXPERIENCED PILOT 避免獨自操控

Before turning on your model and transmitter, check to make sure no one else is operating on the same frequency. Frequency interference can cause your model, or other models to crash. The guidance provided by an experienced pilot will be invaluable for the assembly, tuning, trimming, and actual first flight or unforeseen danger may happen. (Recommend you to practice with computer-based flight simulator.)

至飛行場飛行前，需確認是否有相同頻率的同好正進行飛行，因為開啟相同頻率的發射器將導致自己與他人立即干擾等意外危險。遙控飛機操控技巧在學雷初期有著一定的難度，要盡量避免獨自操作飛行，需有經驗的人士在旁指導，才可以操控飛行，否則將可能造成不可預期的意外發生。(勤練電腦模擬器及老手指導是入門必要的選擇)



## SAFE OPERATION 安全操作

Operate this unit within your ability. Do not fly under tired condition and improper operation may cause in danger. Never take your eyes off the model or leave it unattended while it is turned on. Immediately turn off the model and transmitter when you have landed the model.

請於自己能力內及需要一定技術範圍內操作這台直昇機，過於疲勞、精神不佳或不當操作，意外發生風險將可能會提高。不可在視線範圍外進行，降落後也請馬上關掉直昇機和遙控器電源。



## ALWAYS BE AWARE OF THE ROTATING BLADES 遠離運轉中零件

During the operation of the helicopter, the main rotor and tail rotor will be spinning at a high rate of speed. The blades are capable of inflicting serious bodily injury and damage to the environment. Be conscious of your actions, and careful to keep your face, eyes, hands, and loose clothing away from the blades. Always fly the model a safe distance from yourself and others, as well as surrounding objects.

直昇機主旋翼與尾旋翼運轉時會以高轉速下進行，在高轉速下的旋翼會造成自己與他人在身體上或環境上的嚴重損傷，請勿觸摸運轉中的主旋翼與尾旋翼，並保持安全距離以避免造成危險及損壞。



## KEEP AWAY FROM HEAT 遠離熱源

R/C models are made of various forms of plastic. Plastic is very susceptible to damage or deformation due to extreme heat and cold climate. Make sure not to store the model near any source of heat such as an oven, or heater. It is best to store the model indoors, in a climate-controlled, room temperature environment.









遙控飛機、直昇機多半是以 PA 纖維或聚乙烯、電子商品為主要材質，因此要盡量遠離熱源、日曬，以避免因高溫而變形甚至熔毀損壞的可能。

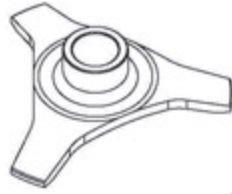
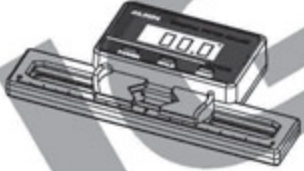

#### RADIO TRANSMITTER AND ELECTRONIC EQUIPMENT REQUIRED FOR ASSEMBLY 自備遙控及電子設備

  <b>Transmitter</b> (7-channel or more, helicopter system) 發射器(七動以上直昇機模式遙控器)	  <b>Receiver(6-channel or more)</b> 接收器(七動以上)	 <b>Remote receiver</b> 衛星天線
  <b>Li-Po Battery Charger RCC-6CX</b> Li-Po電池充電器 RCC-6CX	  <b>22.2V 6S 2600~5200mAh Li-Po Battery x 2</b> 22.2V 6S 2600~5200mAh Li-Po電池 x 2	 <b>Receiver Battery 7.4V 2S</b> 1900~2300mAh Li-Po x 1 接收器電池 7.4V 2S 1900~2300mAh Li-Po x 1

#### ADDITIONAL TOOLS REQUIRED FOR ASSEMBLY 自備工具

 <b>Swashplate Leveler</b> 十字盤調整器	 <b>Digital Pitch Gauge</b> 電子標距規	 <b>Multi-function Tester</b> Voltmeter/Servo Diagnosis 多功能檢測計 電池電壓/伺服器檢測			
 <b>Phillips Screw Driver</b> 十字螺絲起子 φ3.0/φ1.8mm	 <b>Cutter Knife</b> 刀子	 <b>Hexagon Screw Driver</b> 六角螺絲起子 3mm/2.5mm/2mm/1.5mm	 <b>Needle Nose Pliers</b> 尖嘴鉗	 <b>Oil</b> 潤滑油	 <b>CA</b> 瞬間膠

#### 4. PACKAGE ILLUSTRATION 包裝說明

 <p>Canopy 機頭罩</p> <p>700HB1 700HG2 700F3CT 700F3CZ 700HT9</p> <p>700F3CH 700HB8 700HB3 700HB14 700HB10</p> <p>700 F3C Carbon fiber blade x 1set 700 F3C 碳纖主旋翼 x 1組</p> <p>700HT6 Aluminum Tail Boom x 1 鋁合金尾管 x 1</p> <p>Carbon Fiber Tail Boom x 1 碳纖尾管 x 1</p>	<p>RCM-BL750MX Motor x 1 RCM-BL750MX無刷馬達 x 1</p> <p>GP 900 Head Lock Gyro x1 GP 900 鎖定式陀螺儀 x1</p> <p>DS615 Digital Servo x 3 DS615 數位伺服器 x 3</p> <p>DS655 Digital Servo x 1 DS655 數位伺服器 x 1</p> <p>Castle ICE2 HV 120 ESC x 1 Castle ICE2 HV 120 無刷調速器 x 1</p> <p>6A External BEC w/ 5.1V Two-way Step-down voltage regulator x 1 6A 外接式BEC(含5.1V雙向降壓器) x 1</p> <p>Servo extension cable x 2 伺服器延長線 x 2</p>
---	---

**CAREFULLY INSPECT BEFORE REAL FLIGHT 請嚴格執行飛行前之檢查義務**

- Before flying, please check to make sure no one else is operating on the same frequency for the safety.
  - Before flight, please check if the batteries of transmitter and receiver are enough for the flight.
  - Before turn on the transmitter, please check if the throttle stick is in the lowest position. IDLE switch is OFF.
  - When turn off the unit, please follow the power on/off procedure. Power ON- Please turn on the transmitter first, and then turn on receiver. Power OFF- Please turn off the receiver first and then turn off the transmitter. Improper procedure may cause out of control, so please to have this correct habit.
  - Before operation, check every movement is smooth and directions are correct. Carefully inspect servos for interference and broken gear.
  - Check for missing or loose screws and nuts. See if there is any cracked and incomplete assembly of parts. Carefully check main rotor blades and rotor holders. Broken and premature failures of parts possibly cause resulting in a dangerous situation.
  - Check all ball links to avoid excess play and replace as needed. Failure to do so will result in poor flight stability.
  - Check if the battery and power plug are fastened. Vibration and violent flight may cause the plug loose and result out of control.
- 每次飛行前應先確認所使用的頻率是否會干擾他人，以確保您自身與他人的安全。
  - 每次飛行前確定您發射器與接收器電池的電量是在足夠飛行的狀態。
  - 開機前確認油門搖桿是否位於最低點，熄火降落開關，定速開關(IDLE)是否於關閉位置。
  - 關機時必須遵守電源開關機的程序，開機時應先開啟發射器後，再開啟接收器電源；關機時應先關閉接收器後，再關閉發射器電源。不正確的開關程序可能會造成失控的現象，影響自身與他人的安全，請養成正確的習慣。
  - 開機請先確定直昇機的各個動作是否順暢，及方向是否正確，並檢查伺服器的動作是否有干涉或崩齒的情形，使用故障的伺服器將導致不可預期的危險。
  - 飛行前確認沒有缺少或鬆脫的螺絲與螺帽，確認沒有組裝不完整或損毀的零件，仔細檢查主旋翼是否有損壞，特別是接近主旋翼夾座的部位。損壞或組裝不完整的零件不僅影響飛行，更會造成不可預期的危險。注意：每次飛行前的安全檢查、保養、及更換損耗零件，請確實嚴格執行以確保安全。
  - 檢查所有的連桿頭是否有鬆脫的情形，過鬆的連桿頭應先更新，否則將造成直昇機無法操控的危險。
  - 確認電池及電源接頭是否固定牢靠，飛行中的震動或激烈的飛行，可能造成電源接頭鬆脫而造成失控的危險。

**STANDARD EQUIPMENT 標準配備**

 700HC2	 700F3CH	 700HB1	 700HB8	 700HB3
 700HB10	 700HB14	 700HG2	 700F3CT	 700HT9
 700HT6	 700F3CZ	 700 F3C Carbon Fiber Blades x 1 700 F3C 碳纖維主旋翼 x 1	 RCM-BL750MX 450KV Brushless motor x 1 RCM-BL750MX 450KV 無刷馬達 x 1	 M4x4 止洩螺絲 x 2 Motor Siam Thread Pinion Gear 12T x 1 馬達斜齒輪 12T x 1
 DS615 Digital Servo x 3 DS615 數位伺服器 x 3 Metal servo horn 金屬伺服器舵角片 x 3	 DS655 Digital Servo x 1 Ds655 數位伺服器 x 1	 GP900 Head Lock Gyro Combo x 1 GP900 鎖頭式陀螺儀組 x 1	 Castle ICE2 HV 120 ESC x 1 Castle ICE2 HV 120 無刷調速器 x 1	 6A External BEC w/ 5.1V Two-way Step-down voltage regulator 6A 外接式 BEC (含 5.1 雙向降壓器)

When you see the marks as below, please use glue or grease to ensure flying safety.

標有以下符號之組裝步驟，請配合上膠或上油，以確保使用之可靠度。



- CA : Apply CA Glue to fix.
- AB : Apply AB Glue to fix.
- R48 : Apply Anaerobics Retainer to fix.
- T43 : Apply Thread Lock to fix.
- OIL : Add Grease.
- CA : 使用瞬間膠固定
- AB : 使用 AB 膠固定
- R48 : 使用金屬管狀固定缺氣膠固定
- T43 : 使用螺絲膠
- OIL : 添加潤滑油

When assembling ball links, make sure the "A" character faces outside.

各項塑膠製連桿頭扣接時，A字請朝外。



Grease 潤滑油    Green 綠色    Blue 藍色    Self-furnished 附贈膠(白黃)    Self-furnished AB膠(白綠)



T43 Glue width : approx. 1mm  
T43 上膠寬度約 1mm

R48 metal tubular adhesive (eg. Bearings). T43 thread lock, apply a small amount on screws or metal parts and wipe surplus off.

When disassembling, recommend to heat the metal joint about 15 Seconds. (NOTE : Keep plastic parts away from heat.)

R48 為強力金屬管狀 (如軸承) 接著劑，T43 為螺絲膠，膠合螺絲或金屬內外徑請務必少量使用，必要時請用手去除多餘膠量，欲拆卸時可於金屬接合部位熱烤約 15 秒。(注意！塑膠件避免接近熱源)

Apply a little amount of T43 thread lock when fixing a metal part.  
螺絲鎖附於金屬件請使用適量 T43(螺絲膠)

CAUTION 注意

Thrust bearing 止推軸承

Apply grease on thrust bearing.  
止推軸承塗上潤滑油

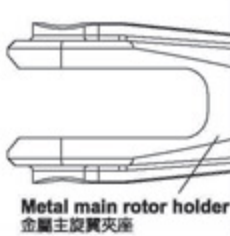
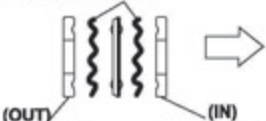

CAUTION 注意

Thrust bearing and washer for radial bearing are wear items, and thus should be inspected for replacement after every 20 flights. For flights with high headspeed, the inspection interval should be reduced to ensure flight safety.  
止推軸承及橫軸墊圈屬於飛行消耗品，建議每20趟定期檢查及更換。高主旋翼轉速飛行時，請縮短定期檢查之週數，以確保飛行安全。

CAUTION 注意

Already assembled by Factory. Before flying, please check if the screws are fixed with glue.  
原廠組裝完成品，每一次飛行前請先確認螺絲是否已上膠不會鬆動。

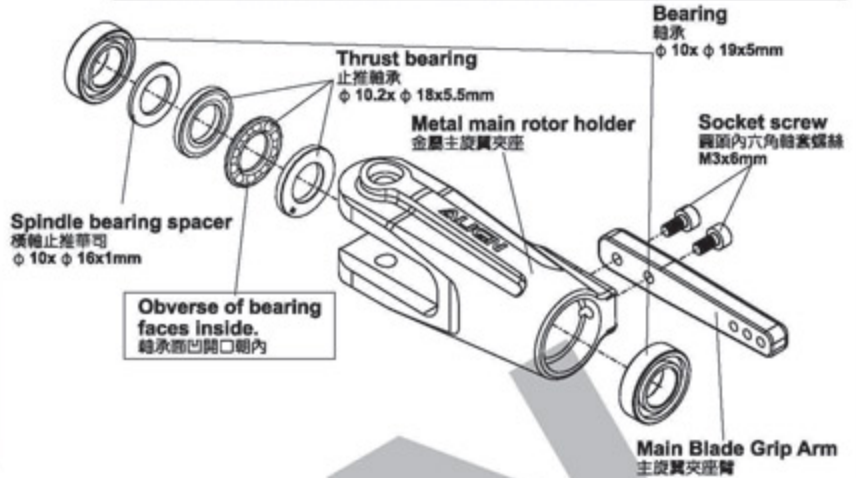

700HH7A

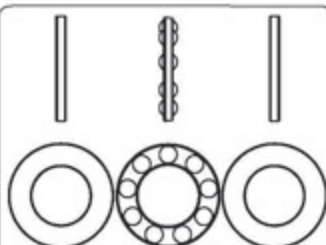

700HH7

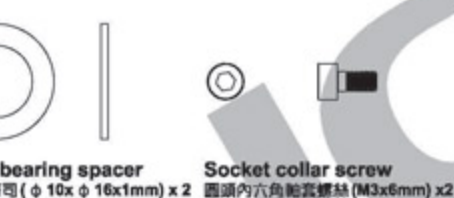
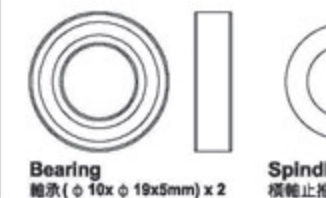

Main Blade Grip (Deltas)  
主旋翼夾座臂 (三角補償)

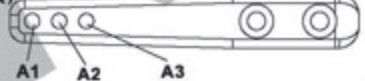

- A1 : Positive Delta: Increase maneuver response speed
  - A2 : Zero Delta: Recommended setting
  - A3 : Negative Delta: Decrease maneuver response speed
- A1 : 正三角補償角：加快動作反應速度  
A2 : 三角補償角 0 度：建議使用  
A3 : 負三角補償角：減緩動作反應速度

700HH7A



700HH8

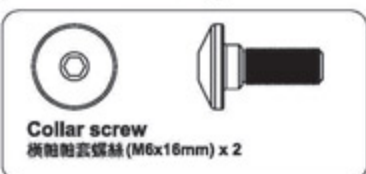

700HH8A

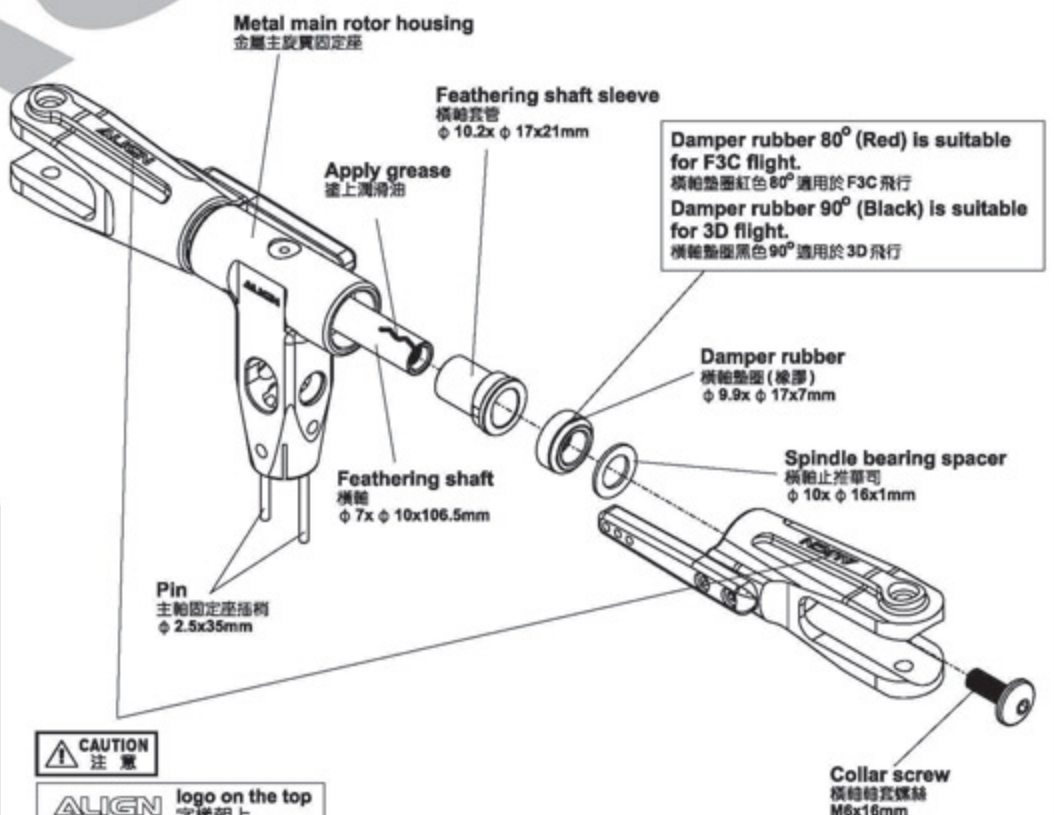
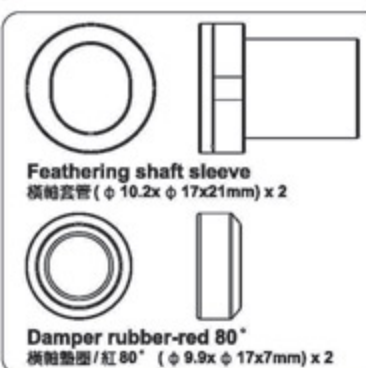

CAUTION 注意

ALIGN logo on the top  
字樣朝上

## 700HH8



**Bearing**  
軸承 (φ 3x φ 7x3mm) x 4



**M3 collar screw**  
M3 軸套螺絲 (M3x9.3mm) x 1



**Bearing**  
軸承 (φ 5x φ 9x φ 2.4mm) x 2



**Washer**  
華司 (φ 3x φ 4.8x0.3mm) x 4



**Collar**  
握臂軸承襯套 (φ 3x φ 4.8x1.5mm) x 2



**Linkage ball A**  
球頭 A (M3x3) φ 5x14.5mm x 2



**Socket button head screw**  
半圓頭內六角螺絲 (M3x12mm) x 2



**Bearing**  
軸承 (φ 4x φ 10x4mm) x 2

**Linkage ball C (M3x3.5)**  
球頭 C (M3x3.5) φ 5x8.5mm

**Collar**  
握臂軸承襯套  
φ 3x φ 4.8x1.5mm

**Mixingarm (U)**  
上混控臂

**Washer**  
華司  
φ 3x φ 4.8x0.3mm

**Bearing**  
軸承  
φ 3x φ 7x3mm

**Bearing**  
軸承  
φ 5x φ 9x φ 2.4mm

**Socket button head screw**  
半圓頭內六角螺絲  
M3x12mm

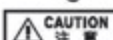

**CAUTION 注意**  
Please apply R48 glue on the collar screw and fasten with appropriate force.  
軸套螺絲請上膠 (R48), 並依適當扭力鎖附。

**M3 collar screw**  
M3 軸套螺絲  
M3x9.3mm

## 700HH8A



**Linkage ball C (M3x3.5)**  
球頭 C (M3x3.5) φ 5x8.5mm x 4

### EFFECT OF ADJUSTMENT MOUNTING HOLES 調整孔位影響特性:

#### Mixingarm (U) (Bell Rate/Flybar Effectiveness) 上混控臂孔位 (貝爾率/修正率)



- B1 : Decrease Collective Pitch Range
  - B2 : Increase Collective Pitch Range
  - C1 : Less flybar effectiveness, more direct control response, agile
  - C2 : More flybar effectiveness, stable control response, gust resistance
- B1 : 集體螺距 Pitch 值較小  
B2 : 集體螺距 Pitch 值較大  
C1 : 修正率較小, 動作反應較直接, 靈敏  
C2 : 修正率較大, 動作反應較安定, 抗風性較佳

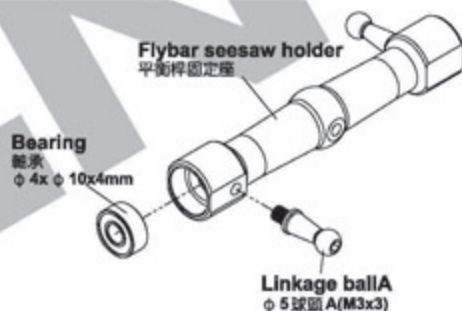

**Flybar seesaw holder**  
平衡桿固定座

**Bearing**  
軸承  
φ 4x φ 10x4mm

**Linkage ball A**  
φ 5 球頭 A (M3x3)

## 700HH9



**Socket screw**  
圓頭內六角螺絲 (M3x6mm) x 4

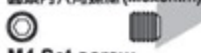

**M4 Set screw**  
M4 止洩螺絲 (M4x4mm) x 2

## 700HH3A

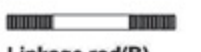

**Linkage rod (B)**  
連桿 (B) (φ 1.96x22mm) x 2



**Ball link**  
連桿頭 x 4

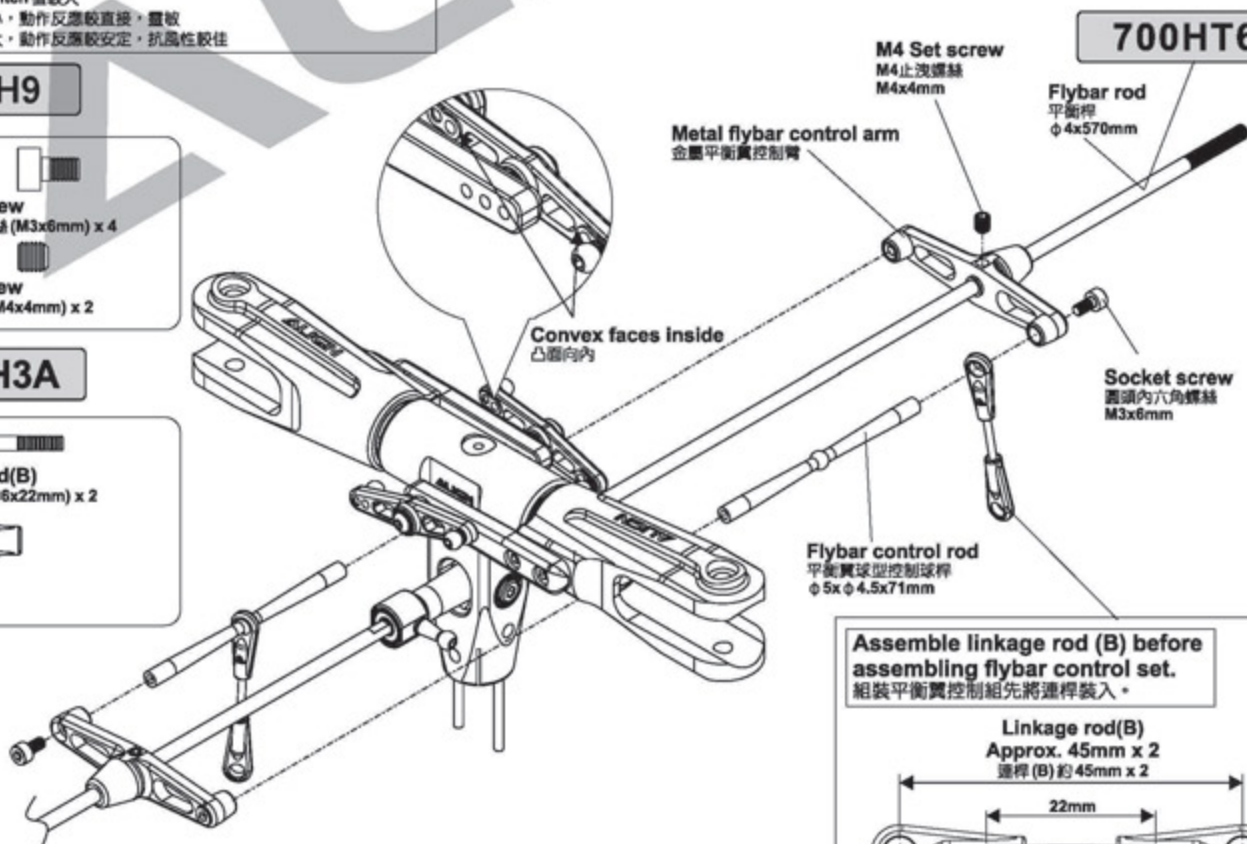

## 700HT6

**M4 Set screw**  
M4 止洩螺絲  
M4x4mm

**Flybar rod**  
平衡桿  
φ 4x570mm

**Metal flybar control arm**  
金屬平衡翼控制臂

**Convex faces inside**  
凸面向內

**Socket screw**  
圓頭內六角螺絲  
M3x6mm



**Flybar control rod**  
平衡翼球型控制球桿  
φ 5x φ 4.5x71mm

**Assemble linkage rod (B) before assembling flybar control set.**  
組裝平衡翼控制組先將連桿裝入。

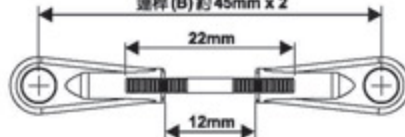

**Linkage rod (B)**  
Approx. 45mm x 2  
連桿 (B) 約 45mm x 2



## 700HH10

-  **Bearing**  
軸承 (φ 2x φ 5x2.3mm) x 4
-  **Socket screw**  
圓頭內六角螺絲 (M2x5mm) x 4



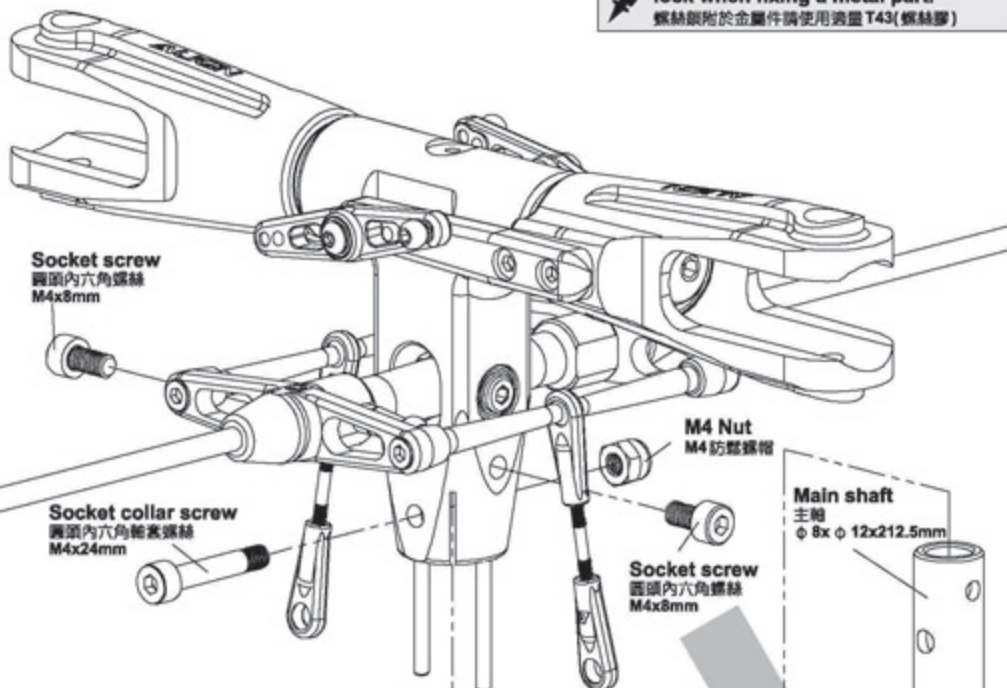

## 700HH5

-  **Linkage ball B(M3x4)**  
球頭B(M3x4)(φ 5x12mm) x 3
-  **Linkage ball C(M3x3.5)**  
球頭C(M3x3.5)(φ 5x8.5mm) x 4

 Apply a little amount of T43 thread lock when fixing a metal part.  
螺絲鎖附於金屬件請使用適量T43(螺絲膠)



## 700HH10A

-  **Linkage ball B(M3x4)**  
球頭B(M3x4)(φ 5x12mm) x 2
-  **Socket screw**  
圓頭內六角螺絲 (M4x8mm) x 2
-  **Socket collar screw**  
圓頭內六角軸套螺絲 (M4x24mm) x 1
-  **M4 Nut**  
M4防鬆螺帽 x 1

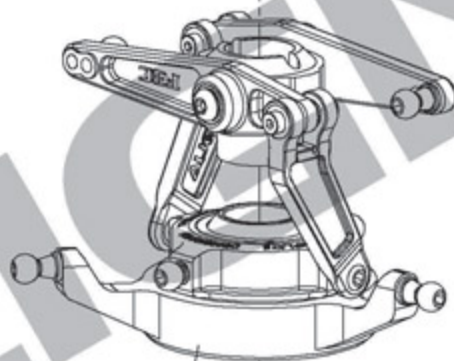

3GX Flybarless system uses 700FL Main shaft.  
Standard Flybar system uses 700 Main shaft.  
3GX 無平衡翼系統使用 700FL 主軸  
有平衡翼系統使用標準 700 主軸



-  **Washer**  
華司 φ 3x φ 4.8x0.3mm
-  **Linkage ball B(M3x4)**  
球頭B(M3x4) φ 5x12mm
-  **Collar**  
圓筒軸承襯套 φ 3x φ 4.8x1.5mm

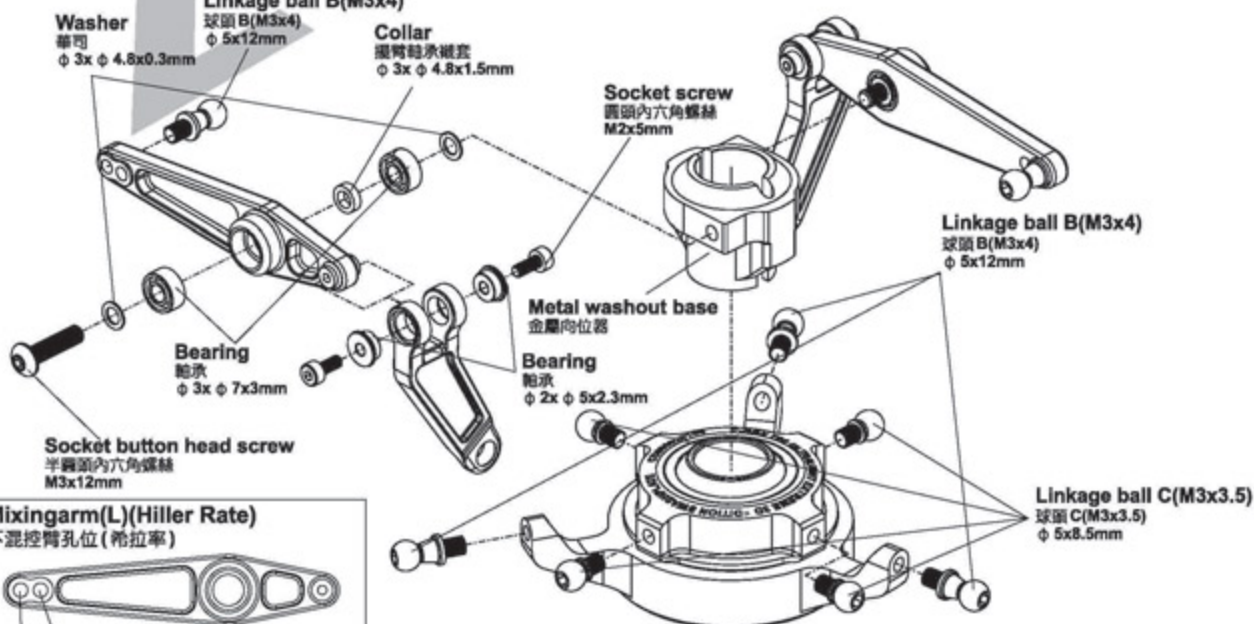

### Mixingarm(L)(Hiller Rate)

下混控臂孔位 (希拉率)



- D1 : Faster and more agile control response
- D2 : Slower and softer control response
- D1 : 動作反應較靈敏快速
- D2 : 動作反應較緩慢柔和

 CAUTION  
注意

Already assembled by Factory. Before flying, please check if the screws are fixed with glue.  
原廠組裝完成品，每一次飛行前請先確認螺絲是否已上膠不會鬆動。



Apply a little amount of T43 thread lock when fixing a metal part.  
螺絲鎖附於金屬件請使用適量 T43(螺絲膠)

## CARBON FIBER FLYBAR REINFORCEMENT TUBE 平衡桿破纖套組立要領

### 700HZ8A



Ball link  
連桿頭 x 4



Ball Links x4  
(use with link rod C)  
連桿頭 x4(連桿 C 專用)

### 700HH8A



Socket screw  
圓頭內六角螺絲 (M3x10mm) x 1

### 700HH3A



M3 Set screw  
M3 止洩螺絲 (M3x6mm) x 2

### 700HZ8



Linkage rod(A)  
連桿 (A)  $\phi$  1.96x14mm x 2



Linkage rod(D)  
連桿 (D)  $\phi$  2.5x84.5mm x 2



Aluminum flybar sleeve (For nimble flight)  
平衡桿鋁套 (靈活飛行特性使用)  
(1g) x 4

Steel flybar sleeve (For stable flight)  
平衡桿鋼套 (穩定飛行特性使用)  
(5g) x 2

Aluminum or steel flybar sleeve (For stable flight) can be selected based on flight condition requirements.  
可依不同飛行特性要求，選擇使用平衡桿鋁套或平衡桿鋼套(動作更穩定)。

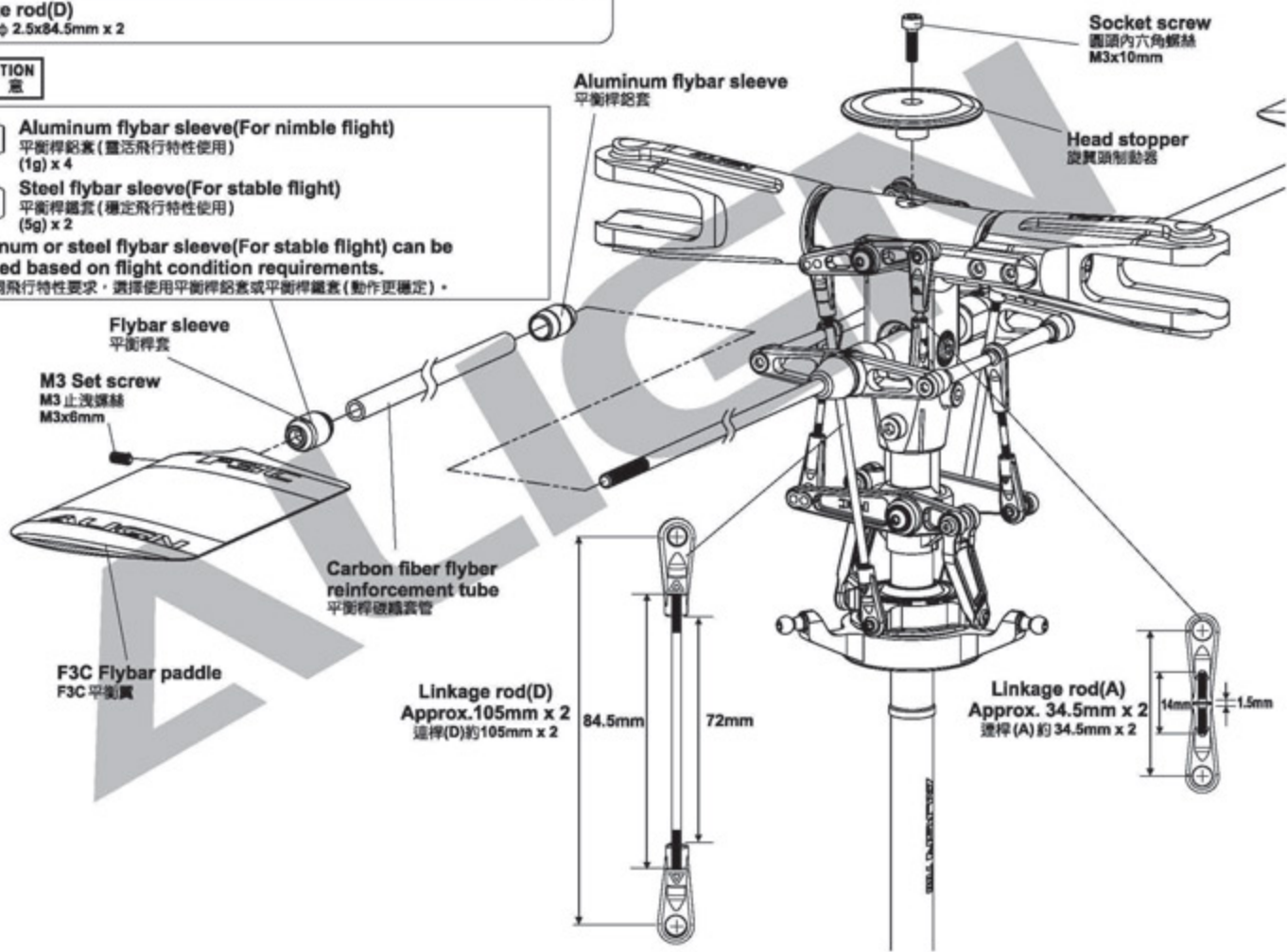

- Mix thoroughly suitable amount of epoxy.
- Apply generous amount of epoxy on the tips of carbon tube after sliding over the linkage rod.  
(Suggest to use the AB glue that hardened in 30 mins.)  
(Note: for quick drying epoxy, work fast as it must be applied prior to curing)
- Slide the flybar sleeves on both sides of the carbon tube.  
1: 使用適量的 AB 膠，並且均勻的攪拌混合  
2: 將破纖管兩端塗上 AB 膠 (建議使用 30 分鐘硬化的 AB 膠)  
(注意: 若使用速乾型 AB 膠請務必於膠乾固前組裝完成)  
3: 接著將平衡桿套分別套入破纖管兩端
- The base to base length is approx. 204mm.  
4: 跨距約為 204mm

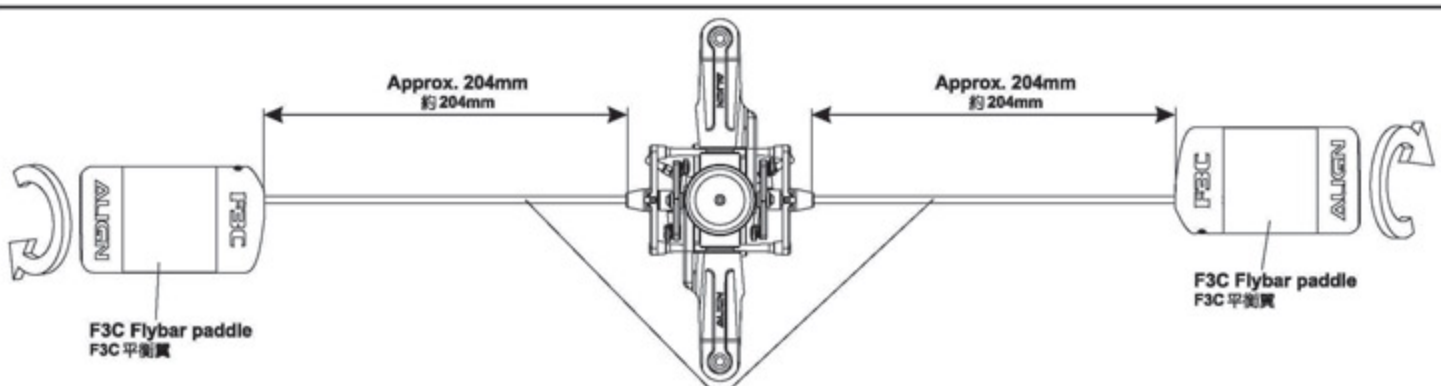

Make sure both sides are equal in length.  
請保持平衡桿兩邊長度相等。

### 700HB3A

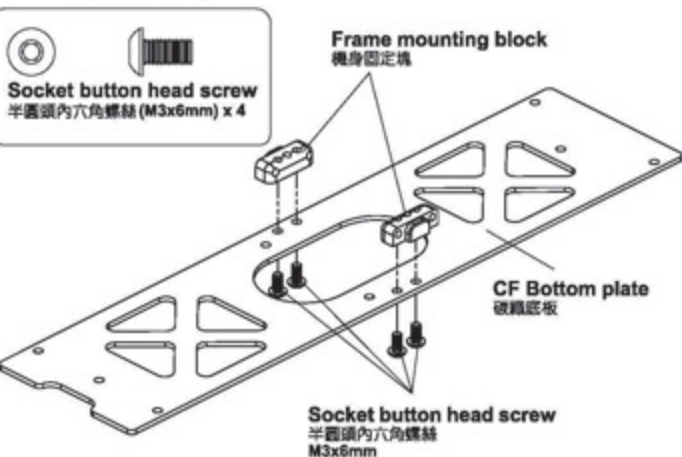

### 700HZ11

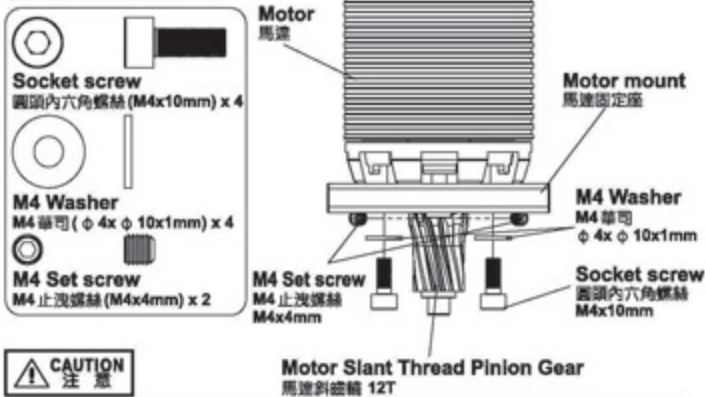

Make sure the motor mount is fully fastened before fasten the motor pinion gear mount.  
先將馬達固定座鎖緊固定後，再將馬達齒座鎖緊。

### 700HB3

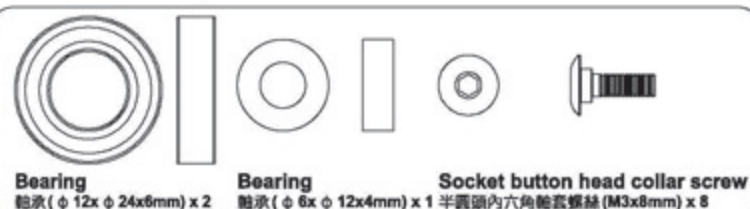

### 700HB9A

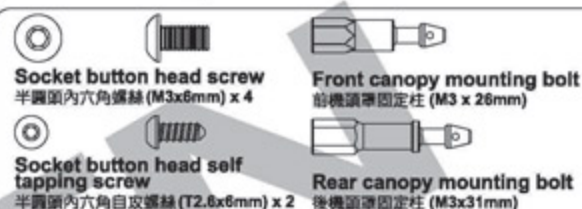

### 700HB3A

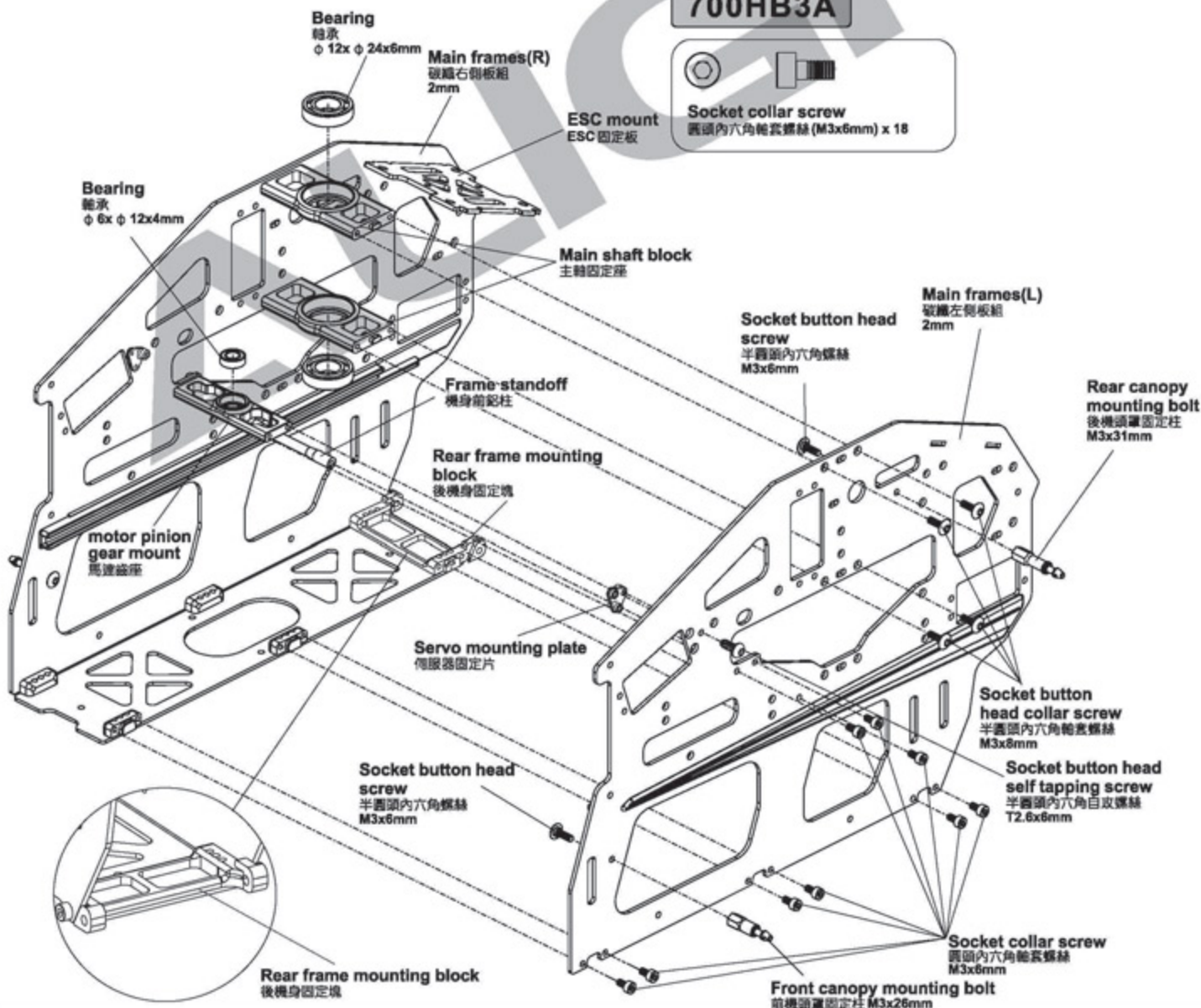



注意

**Main frame assembly key point :**

First do not fully tighten the screws of main frames and put two bearings through the main shaft to check if the movements are smooth. The bottom bracket must be firmly touched the level table top(glass surface) ; please keep the smooth movements on main shaft and level bottom bracket, then slowly tighten the screws. This assembly can help for the power and flight performance.

**機身側板組立重點：**

側板螺絲先不完全鎖緊，放入主軸貫穿二顆軸承確認上下移動必需滑順，主體底板必須與水平桌面（玻璃平面）踏實緊貼；請保持主軸滑順與底板平行桌面後慢慢鎖緊螺絲。正確側板的組裝對動力與飛行性能有顯著幫助。

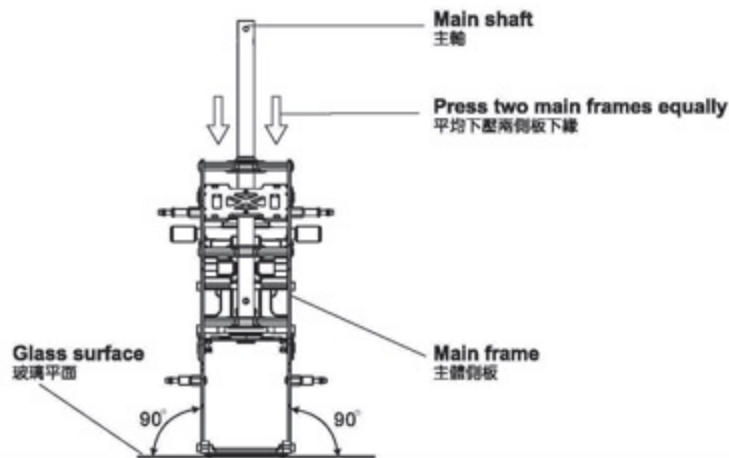

**700HG1A**



Socket screw  
圓頭內六角螺絲 (M3x10mm) x 4



M3 Washer  
M3 華司 (φ 3x φ 8x1mm) x 4



M3 Set screw  
M3 止洩螺絲 (M3x4mm) x 4

**700HB9A**



Socket screw  
圓頭內六角螺絲 (M3x14mm) x 2



Socket collar screw  
圓頭內六角軸套螺絲 (M3x6mm) x 2

**700HB10**

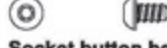

Socket button head self tapping screw  
半圓頭內六角自攻螺絲 (T3x8mm) x 1

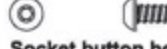

Socket button head self tapping screw  
半圓頭內六角自攻螺絲 (T3x12mm) x 2

Apply a little amount of T43 thread lock when fixing a metal part.  
螺絲鎖附於金屬件請使用適量 T43(螺絲膠)

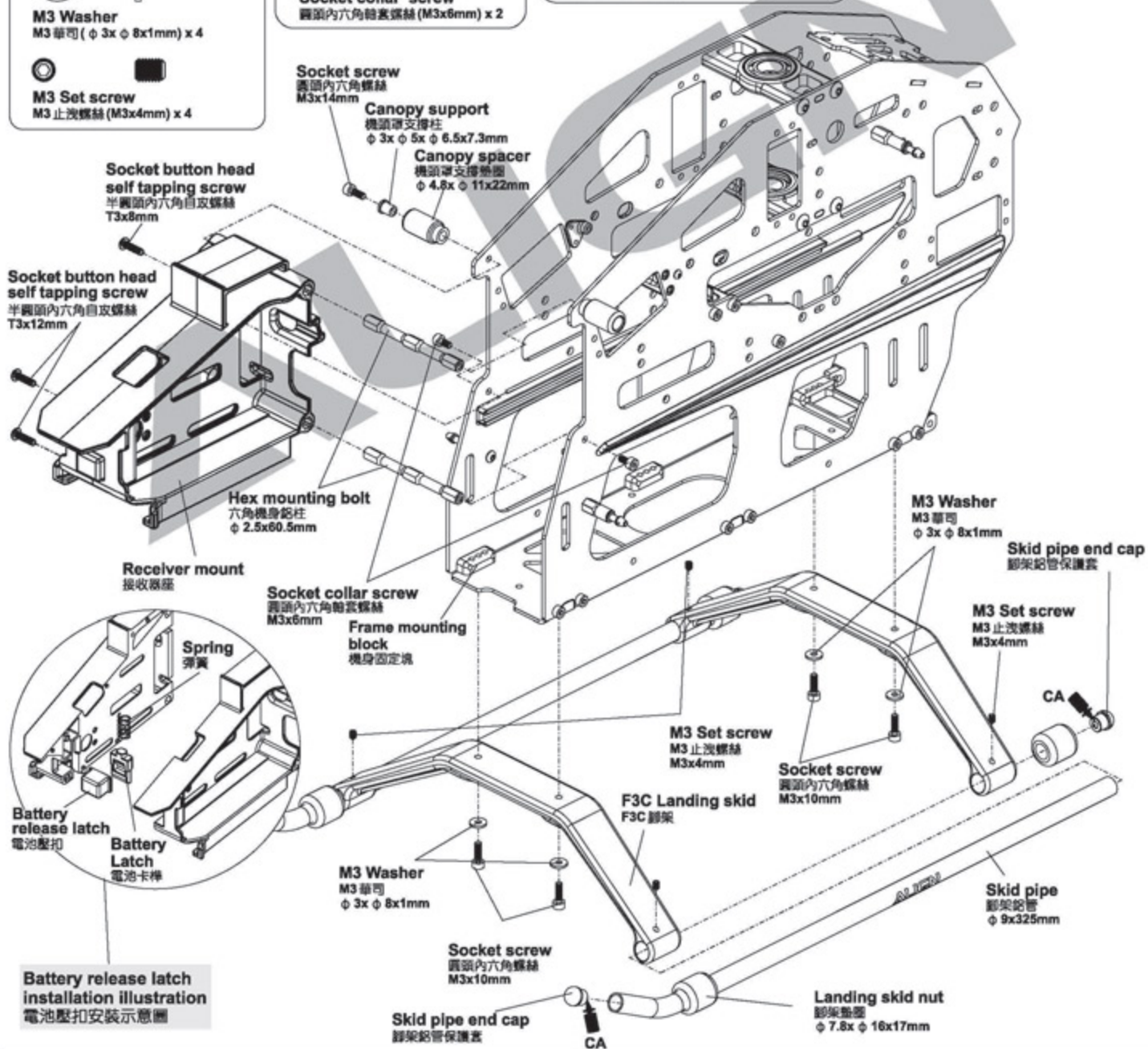

# 700HZ6

Apply a little amount of T43 thread lock when fixing a metal part.  
螺絲鎖附於金屬件請使用適量T43(螺絲膠)

-  **Linkage ball C(M2x4)**  
球頭C(M2x4)( $\phi$  5x9mm) x 4
-  **Socket button head self tapping screw**  
半圓頭內六角自攻螺絲 (T2.6x12mm) x 4
-  **Socket button head screw**  
半圓頭內六角螺絲 (M2.5x12mm) x 4
-  **Socket button head screw**  
半圓頭內六角螺絲 (M3x6mm) x 4
-  **M2 Nut**  
M2 螺帽 x 4

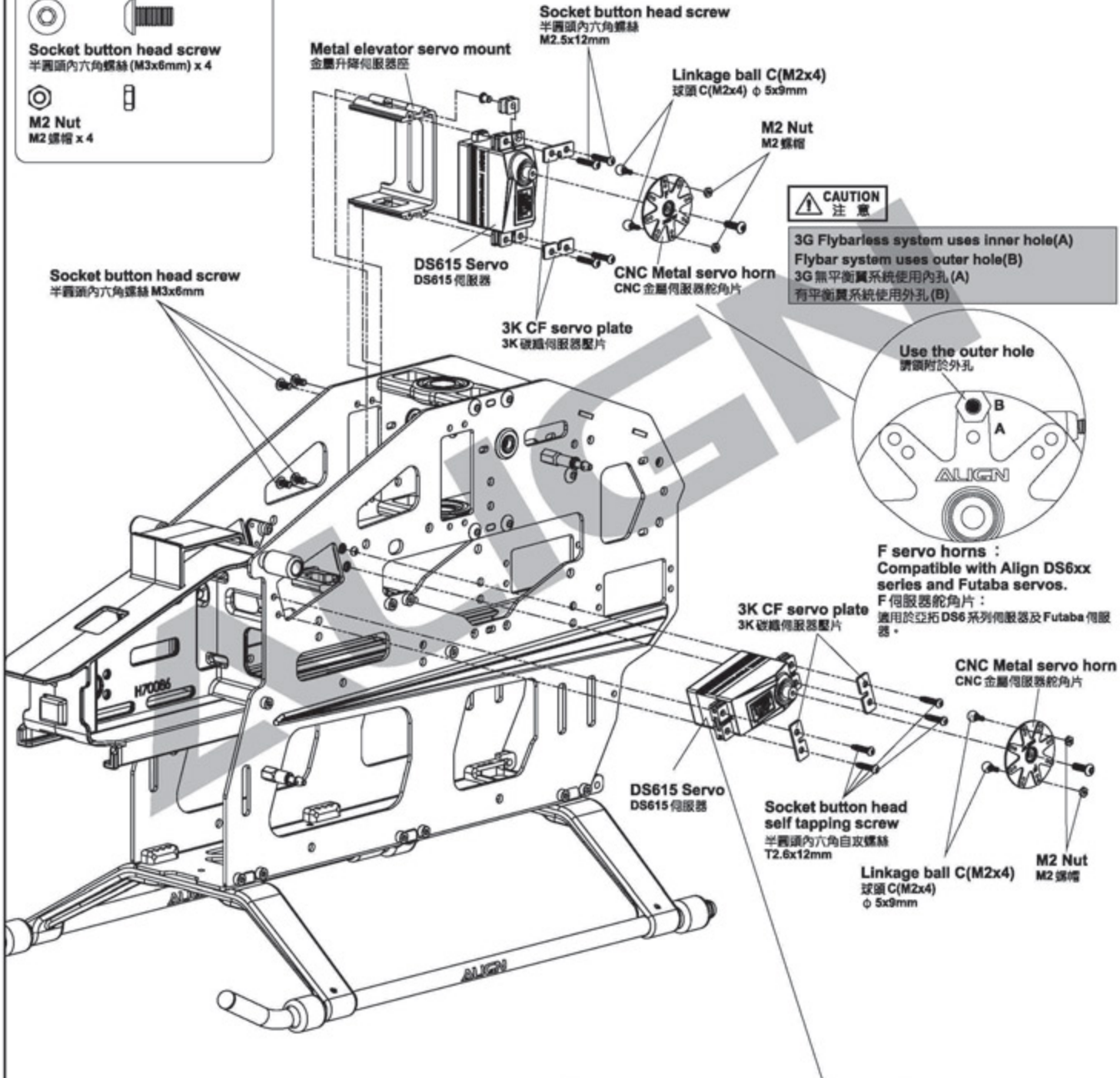

**CAUTION 注意**  
3G Flybarless system uses inner hole(A)  
Flybar system uses outer hole(B)  
3G 無平衡翼系統使用內孔(A)  
有平衡翼系統使用外孔(B)



**F servo horns :**  
Compatible with Align DS6xx series and Futaba servos.  
F 伺服器舵角片：  
適用於亞拓 DS6 系列伺服器及 Futaba 伺服器。

**DS615 Digital Servo :**  
1. 1520  $\mu$  s standard band / 1520  $\mu$  s 寬頻系統  
2. Stall torque/輸出扭力 : 10.4kg.cm(4.8V)  
12.8kg.cm(6.0V)  
3. Motion speed/動作速度 : 0.09sec/60° (4.8V)  
0.07sec/60° (6.0V)  
4. Dimension/尺寸 : 40.1 x 20.1 x 37.3mm  
5. Weight/重量 : 56g

## 700HZ6



## 700HB3A



## 700HZ11

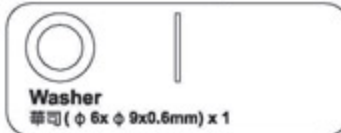

Recommend sanding the marked position as below illustration with a waterproof abrasive paper(#800-1000) to avoid the wires of electric parts to be cut.

建議於下圖色塊標示處，使用#800-1000水砂紙打磨，可防止電子設備電線被割破。

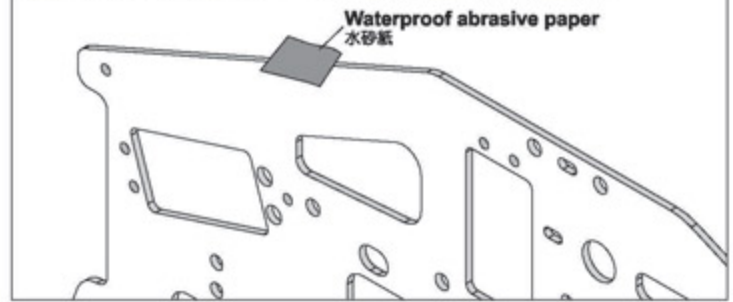

### CAUTION 注意

Make sure the motor mount is fully fastened before fasten the motor pinion gear mount.  
先將馬達固定座鎖緊固定後，再將馬達齒座鎖緊。

DS615 Digital Servo :  
1.1520 μ s standard band /1520 μ s 寬頻系統  
2.Stall torque/輸出扭力: 10.4kg.cm(4.8V)  
12.8kg.cm(6.0V)  
3.Motion speed/動作速度: 0.09sec/60° (4.8V)  
0.07sec/60° (6.0V)  
4.Dimension/尺寸: 40.1 x 20.1 x 37.3mm  
5.Weight/重量: 56g

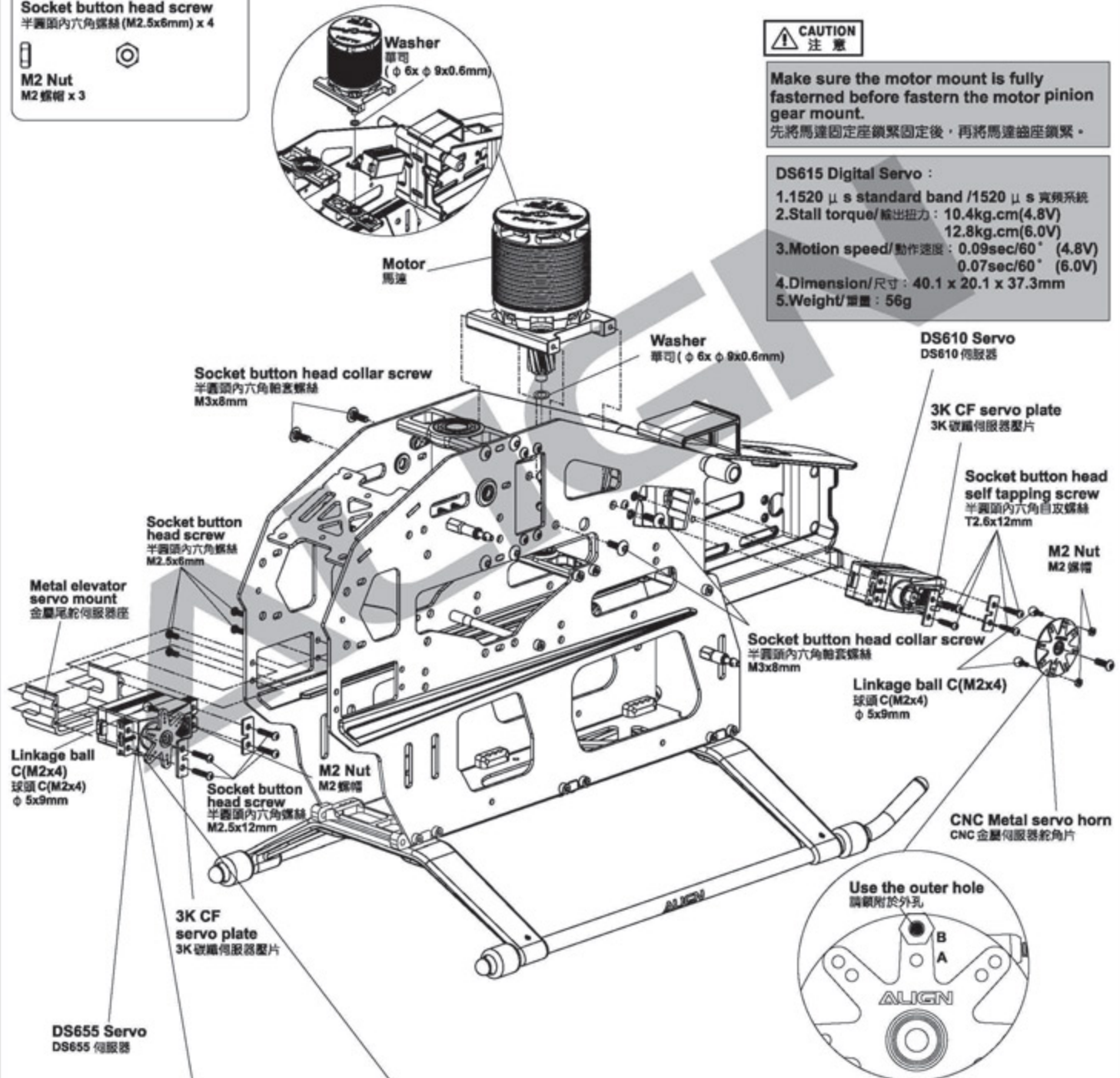

DS655 Digital Servo :  
1.1520 μ s standard band /1520 μ s 寬頻系統  
2.Stall torque/輸出扭力: 4.5kg.cm(4.8V)  
5.5kg.cm(6.0V)  
3.Motion speed/動作速度: 0.06sec/60° (4.8V)  
0.05sec/60° (6.0V)  
4.Dimension/尺寸: 40.1 x 20.1 x 37.3mm  
5.Weight/重量: 56g

### CAUTION 注意

3G Flybarless system uses inner hole(A)  
Fiybar system uses outer hole(B)  
3G 無平衡翼系統使用內孔(A)  
有平衡翼系統使用外孔(B)

Apply a little amount of T43 thread lock when fixing a metal part.  
螺絲鎖附於金屬件請使用適量T43(螺絲膠)

### 700HB3



### 700HB3A



Please fasten the elevator ball link and screws all the way in.  
升降桿連桿頭及螺絲請鎖緊。

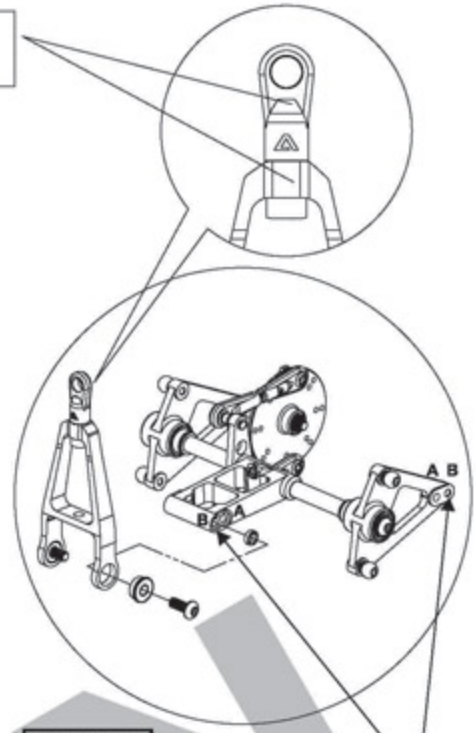

3G Flybarless system uses inner hole(A)  
Flybar system uses outer hole(B)  
3G 無平衡翼系統使用內孔(A)  
有平衡翼系統使用外孔(B)

### 700HZ8

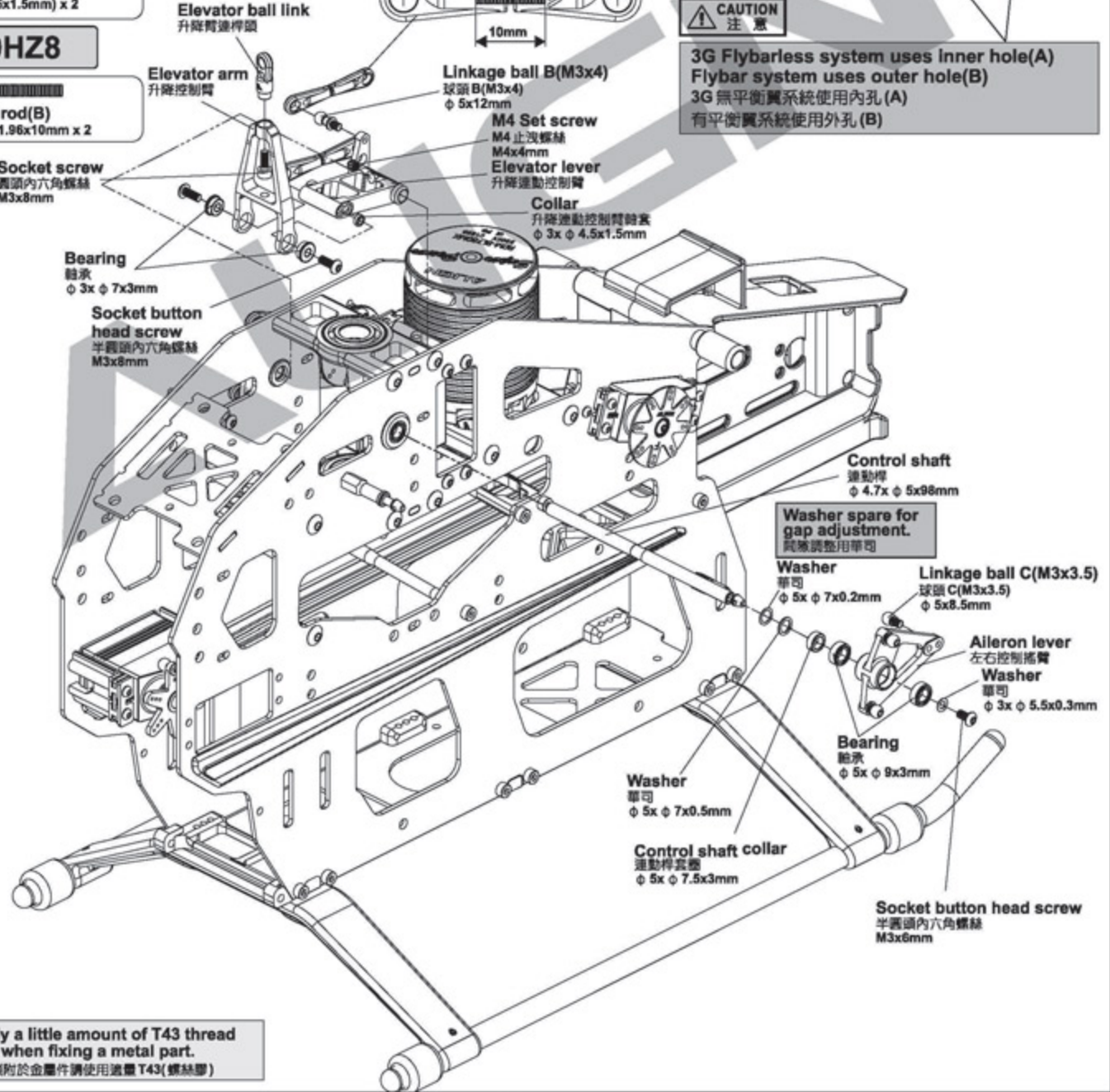
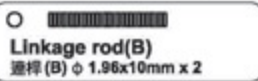

Apply a little amount of T43 thread lock when fixing a metal part.  
螺絲鎖附於金屬件請使用適量 T43(螺絲膠)

## 700HZ8

⊙   
**Aileron Control rod Carbon Fiber Tube**  
 升降控制連桿碳纖維管 (  $\phi 2.2 \times \phi 3.9 \times 96 \text{mm}$  ) x 4

○   
**Linkage rod(F)**  
 連桿(F)  $\phi 1.96 \times 110 \text{mm}$  x 4

## 700HZ8A

  
**Ball link**  
 連桿頭 x 8

  
**Aileron Control rod Carbon Fiber Shaft**  
 升降控制連桿碳纖維套 (  $\phi 4 \times \phi 5.4 \times 6.5 \text{mm}$  ) x 8

### AILERON CARBON FIBER LINKAGE ROD SET

### 副翼控制碳纖維連桿組要領



- 1: Mix thoroughly suitable amount of epoxy.
- 2: Apply generous amount of epoxy on the tips of carbon tube after sliding over the linkage rod. (Suggest to use the AB glue that hardened in 30 mins.)  
 (Note: for quick drying epoxy, work fast as it must be applied prior to curing)

- 1: 使用適量的AB膠，並且均勻的攪拌混合
- 2: 將已套入連桿的碳纖維管兩端塗上AB膠 (建議使用30分鐘硬化的AB膠)  
 (注意: 若使用速乾型AB膠請務必於膠乾固前組裝完成)



- 3: Slide the carbon end caps on both sides of the carbon tube.
- 3: 接著將碳纖維套分別套入碳纖維管兩端



- 4: Thread the ball links onto the linkage rod until the base to base length is 97.5mm.
- 4: 將連桿頭鎖入連桿至跨距為97.5mm的位置



- 5: If gap exists between the ball link and end caps after correct length has been achieved, slide the end caps outwards to cover the gaps  
 (note: must be done before epoxy cures)

- 6: Wipe away excess epoxy and set it aside to cure.
- 5: 碳纖維套與連桿頭會有些許的間隙，此時請將碳套往兩側推至切齊連桿頭  
 (注意: 須在AB膠未乾固時完成此動作)
- 6: 將多餘的殘膠擦拭乾淨後請靜置AB膠乾固方可使用

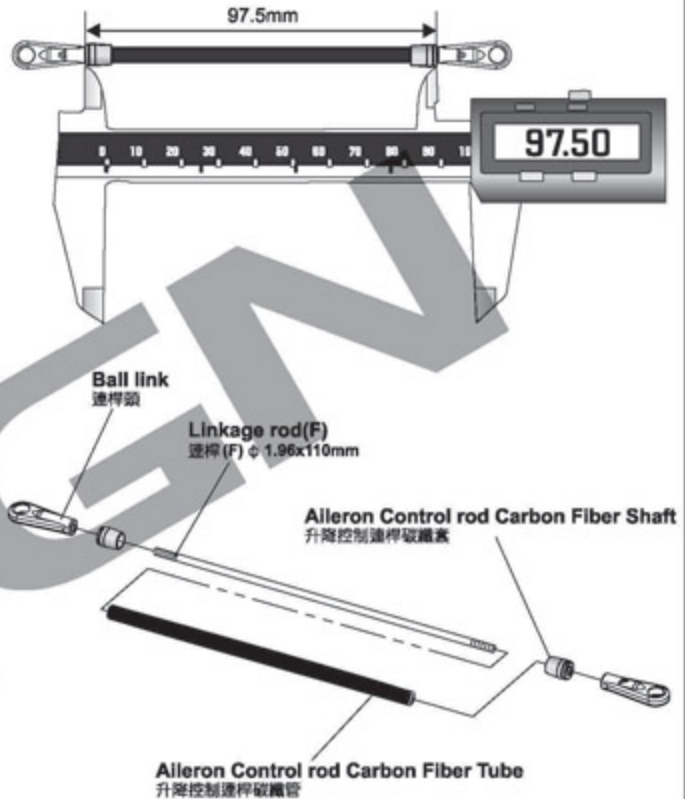

Linkage rod(F)  
Approx. 130.5mm x 4  
連桿(F) 約 130.5mm x 4

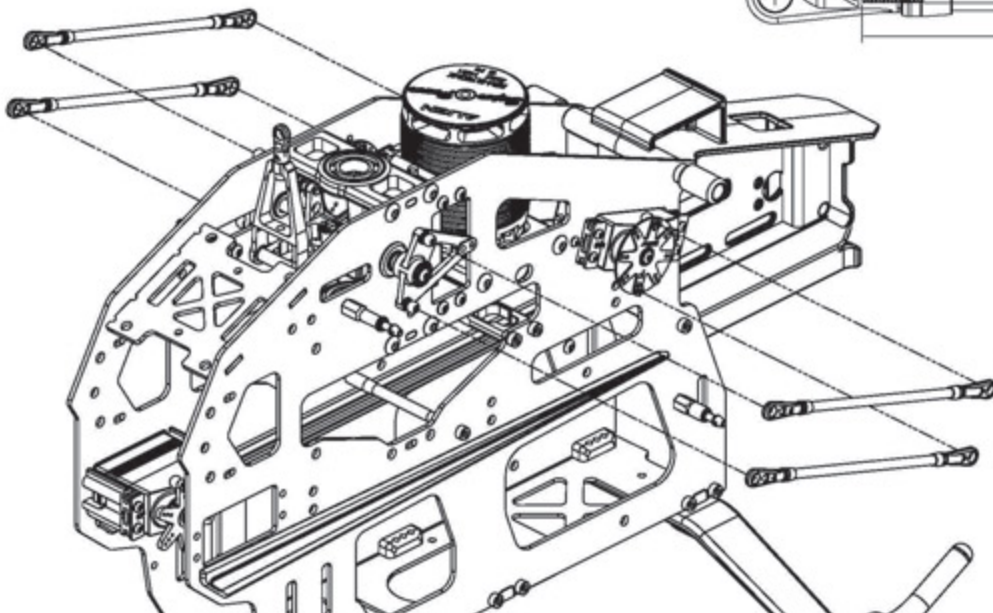

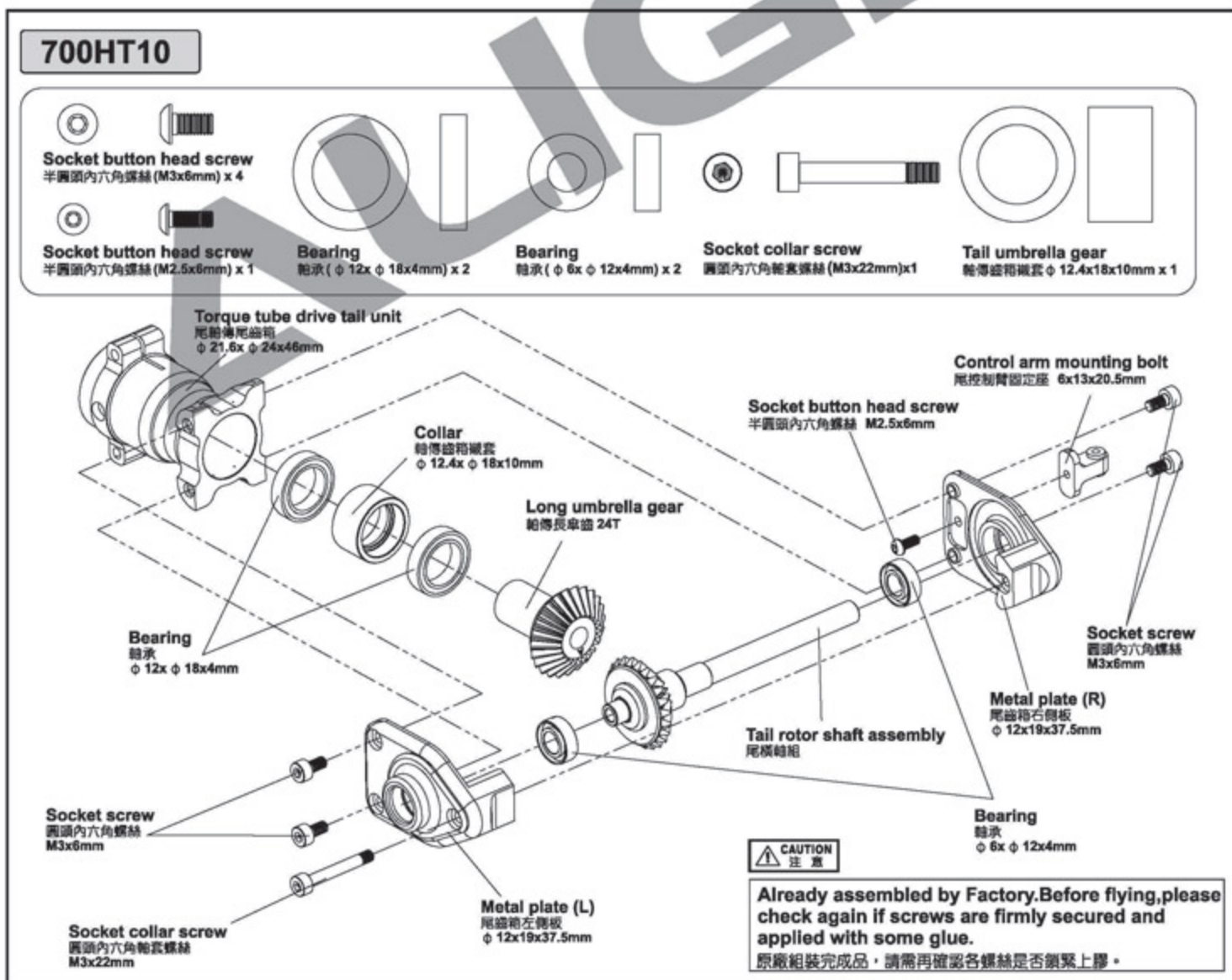
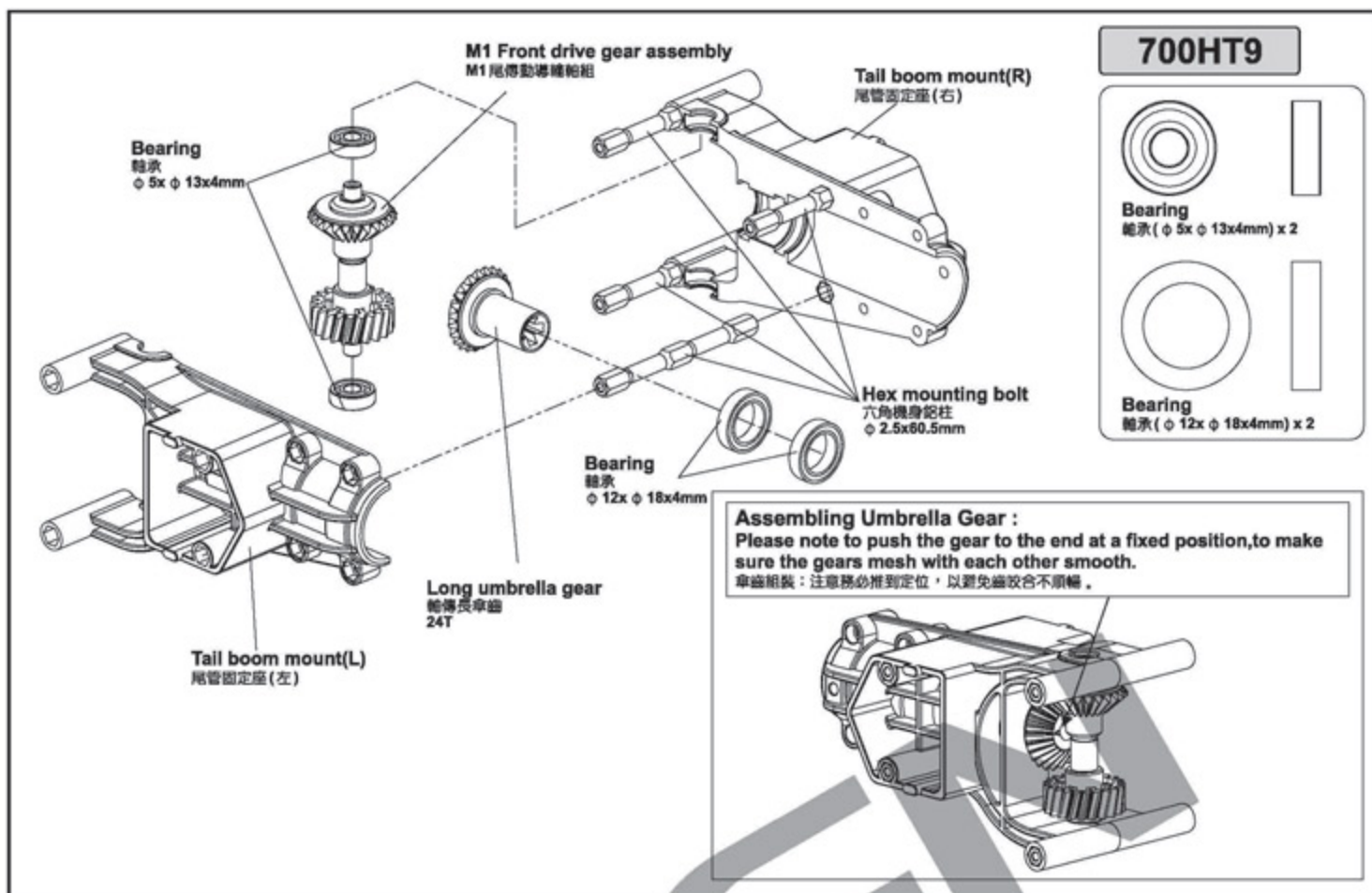



# 700HT10

- Collar screw 輪套螺絲-銀 (M2x8mm)(牙長3mm) x 2
- Collar screw 輪套螺絲 (M2x8mm)(牙長4.3mm) x 2
- Socket screw 圓頭內六角螺絲 (M2x8mm) x 2
- Collar A 尾座桿頭鋼套 A (φ 2x φ 3x4mm) x 2
- Bearing 軸承 (φ 8x φ 12x3.5mm) x 2
- Slide shaft 尾軸滑套 x1
- Bearing 軸承 (φ 2.5x φ 7.1x2.6mm) x 6
- Socket button head screw 半圓頭內六角螺絲 (M2.5x5mm) x 6
- Socket button head screw 半圓頭內六角螺絲 (M3x5mm) x 1
- Socket collar screw 圓頭內六角輪套螺絲 (M3x8mm) x 2
- Thrust bearing 止推軸承 (φ 5x φ 10x4mm) x 2
- Bearing 軸承 (φ 6x φ 10x3mm) x 4
- Washer 華司 (φ 3x φ 8x1mm) x 2
- M4 Set screw M4 止洩螺絲 (M4x4mm) x 1
- Washer 華司 (φ 8x φ 10x0.3mm) x 2
- Linkage ball C (M2x4) 球頭 C (M2x4) (φ 5x9mm) x 1

# 700HT12

- Socket collar screw 圓頭內六角輪套螺絲 (M3x17mm) x 2
- M3 Nut M3 防鬆螺帽 x 2

**CAUTION 注意**

Apply grease on thrust bearing. 止推軸承塗上潤滑油

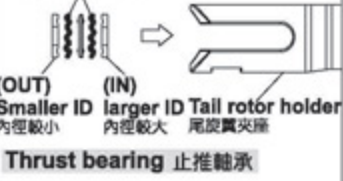

While assembly the slide shaft, please use suitable amount of T43 on the thread. Please do not use R48 anaerobics retainer or other high strength glue to avoid damages while maintenance or repairs.  
組立尾軸滑套時，請使用適量的 T43 螺絲膠在螺牙上，嚴禁使用 R48 高膠合性軸承膠防止膠合過緊，以避免日後拆修破壞零件之損傷。

Apply a little amount of T43 thread lock when fixing a metal part.  
螺絲鎖附於金屬件請使用適量 T43 (螺絲膠)

**CAUTION 注意**

Assembling Umbrella Gear: Please note to push the gear to the end at a fixed position, to make sure the gear mesh with each other smoothly.  
傘齒組裝：注意務必前推到底定位，以避免齒咬合不順暢。

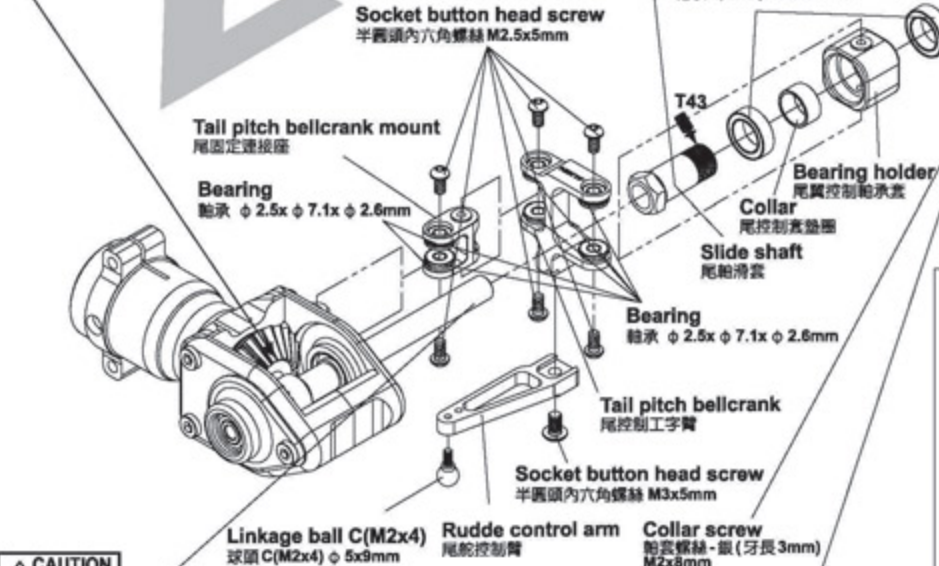

**CAUTION 注意**

Aim tail rotor hub at the concave of tail rotor shaft and fix it, please apply a little glue on the set screw.  
尾旋翼T型座瞄準尾橫軸的凹刻並鎖上，請確認止洩螺絲上膠。

Please tighten M2x8mm collar screw firmly but not over tightened. Over tighten the screw will cause the operation of control link unsmoothly.  
鎖附 M2x8mm 輪套螺絲請使用適當力道，過度鎖緊會造成尾控制連桿轉動不順。

**CAUTION 注意**

After complete the tail rotor assembly, please check if it rotates smoothly.  
尾旋翼組裝完成後需確認尾旋翼夾座轉動滑順。

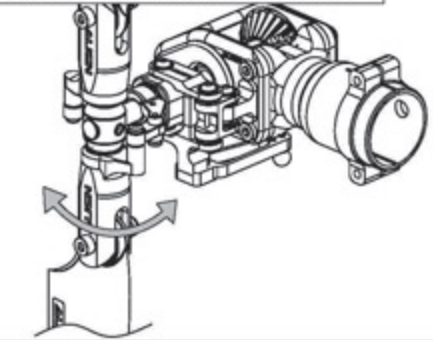

Already assembled by factory, please note to check again.  
已組裝完成，請務必自行再確認。

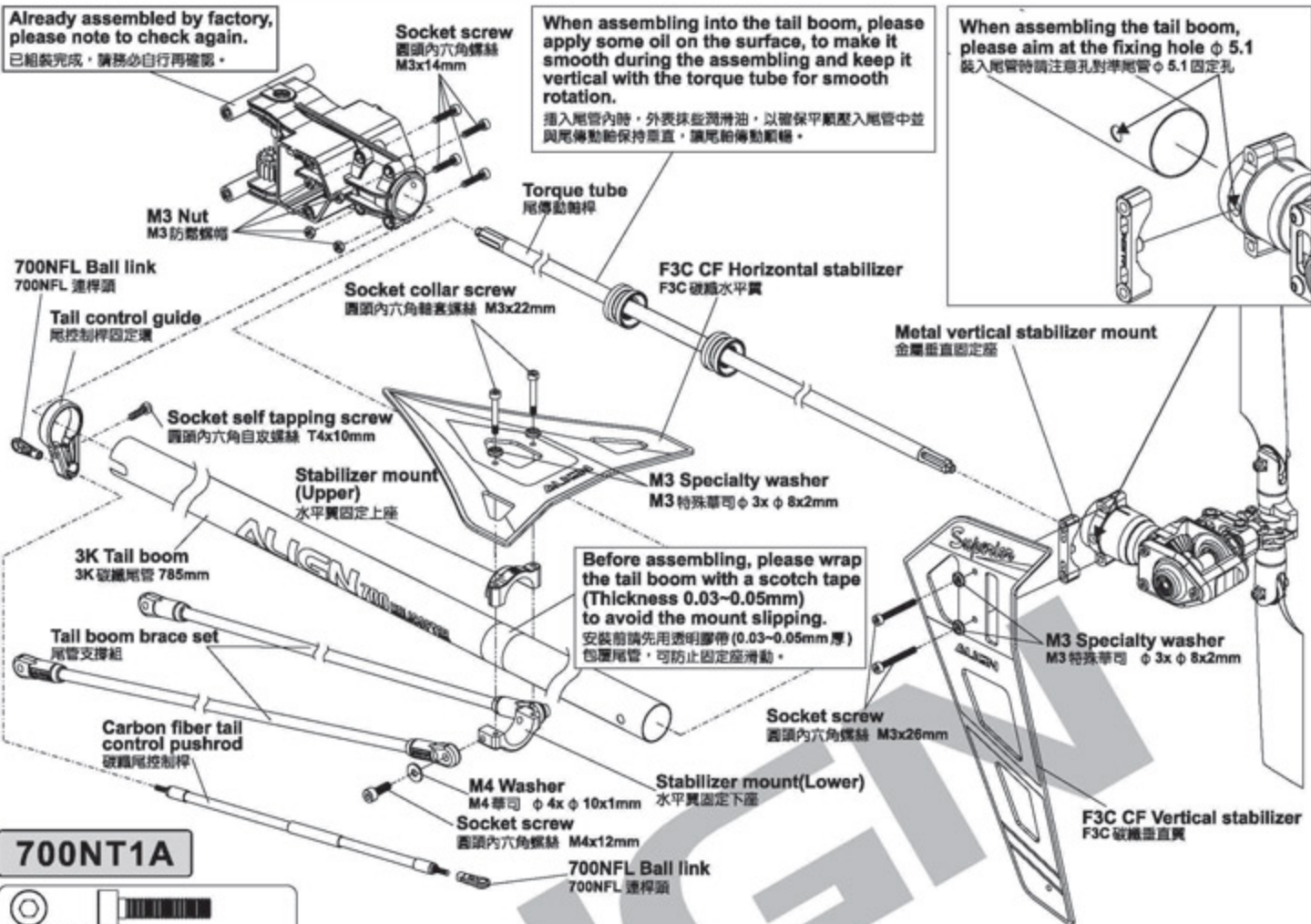

### 700NT1A



### 700HT10



### 700NT2EA



### 700HT6



### TIP TO FIX THE TORQUE TUBE 傳動軸軸承固定位要領

Please apply some CA glue to fix bearing on the torque tube, avoid CA glue from the dust or may cause the bearing stuck. When assembling into the tail boom, please apply some oil and use the attached torque tube mount helper to press the bearing holder of the torque tube into the tail boom horizontally.

請以少量 CA 將軸承固定於尾傳動軸上，避免 CA 沾到軸承的防護蓋而導致軸承卡死，插入尾管內時，尾傳動軸承蓋圈外表抹些潤滑油，利用隨附軸承座安裝套管將尾傳動軸承蓋圈平行壓入尾管中不可歪斜。

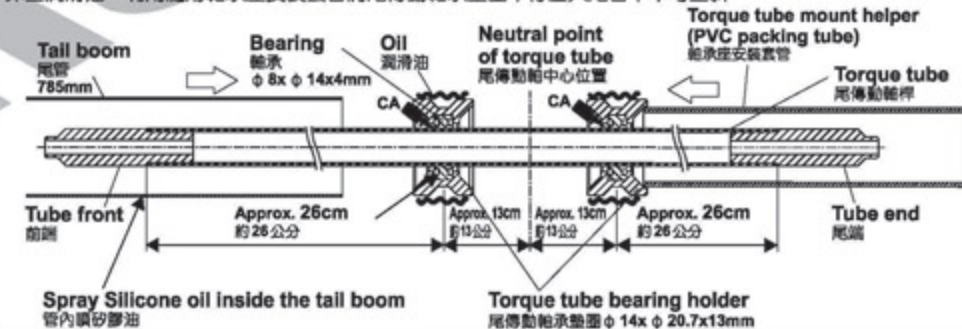

**CAUTION 注意**  
Skewed Torque tube bearing holder will interfere with torque tube rotation and cause unusual vibration.  
尾傳動軸承座安裝歪斜會造成傳動軸運轉不順及尾部異常震動等問題

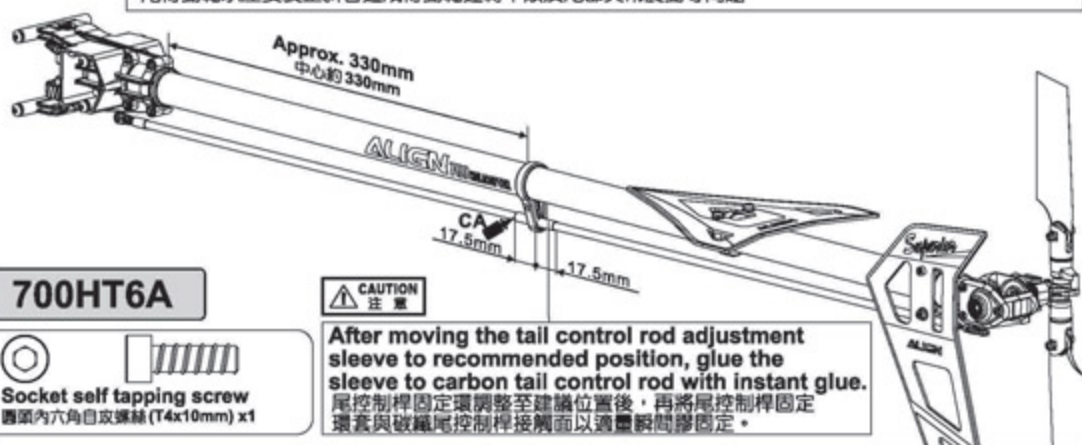

### 700HT6A



Apply a little amount of T43 thread lock when fixing a metal part.  
 螺絲鎖附於金屬件請使用適量 T43 (螺絲膠)

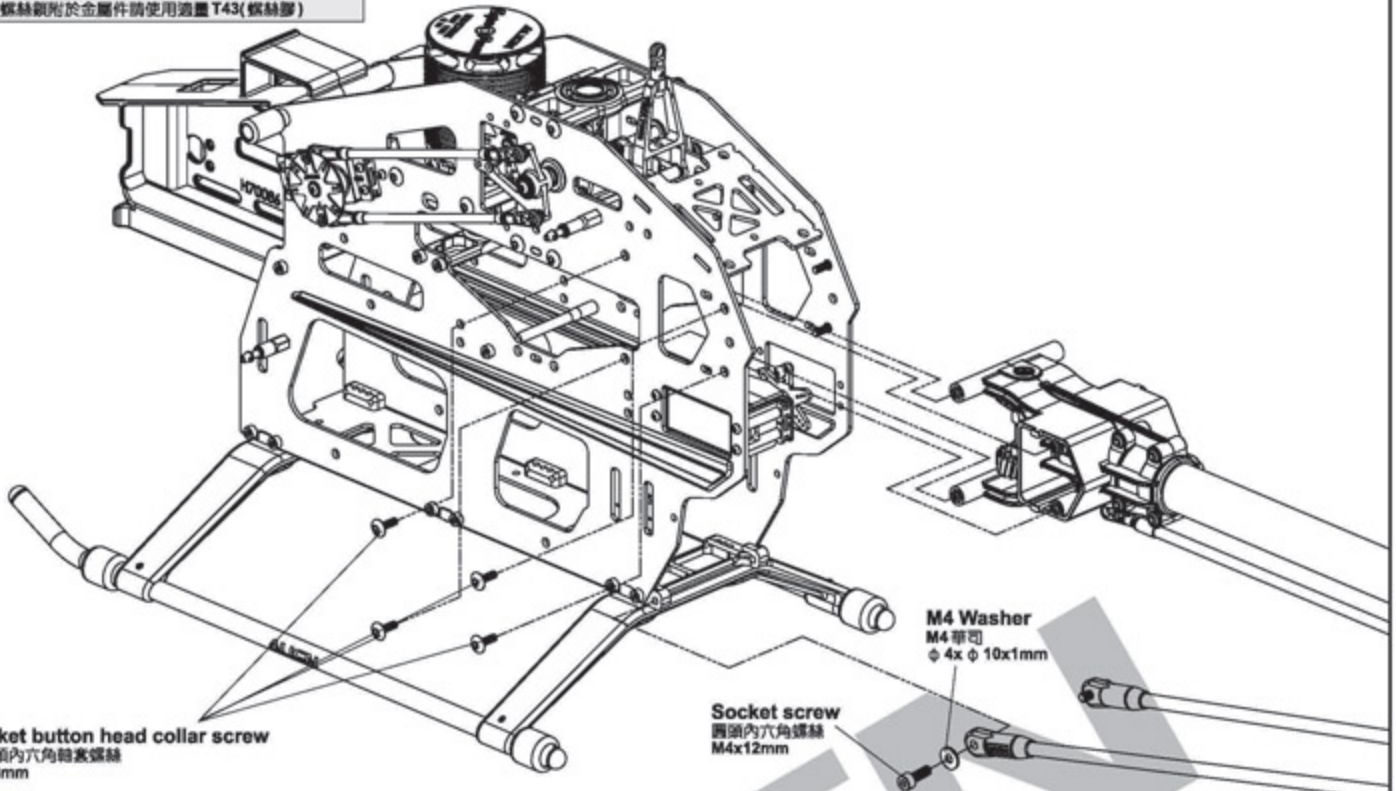

Socket button head collar screw  
 半圓頭內六角軸套螺絲  
 M3x8mm

Socket screw  
 圓頭內六角螺絲  
 M4x12mm

M4 Washer  
 M4 華司  
 φ 4x φ 10x1mm

Tail boom fixing screw  
 尾管固定螺絲

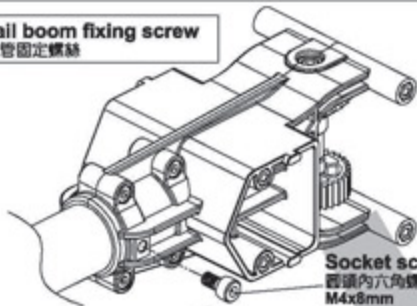

Socket screw  
 圓頭內六角螺絲  
 M4x8mm

**700HB3A**

Socket screw  
 圓頭內六角螺絲 (M4x12mm) x 2

M4 Washer  
 M4 華司 (φ 4x φ 10x1mm) x 2

**700NT1A**

Socket button head collar screw  
 半圓頭內六角軸套螺絲 (M3x8mm) x 8

Socket screw  
 圓頭內六角螺絲 (M4x8mm) x 1

**700HB14**

Bearing  
 軸承 (φ 15x φ 21x4mm) x 2

One-way bearing  
 單向軸承 (φ 15x φ 23x11mm) x 1

Spacer  
 700 單向墊片 φ 18x φ 22.7x0.7mm x 1

Socket screw  
 圓頭內六角螺絲 (M2.5x8mm) x 6

Socket Screw  
 圓頭內六角螺絲 (M3x8mm) x 6

Socket screw  
 圓頭內六角螺絲 M3x8mm

Washer  
 華司 φ 3x φ 4.8x0.6mm

CNC Slant Thread Main Drive Gear  
 CNC 斜主齒輪 112T

One-way bearing cover  
 單向軸承上蓋  
 φ 21x φ 15.8x26mm

Washer  
 華司 φ 3x φ 4.8x0.6mm x 6

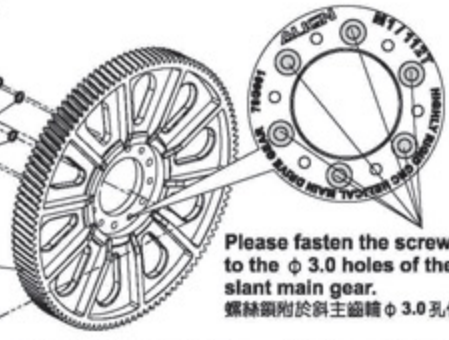

Please fasten the screws to the φ 3.0 holes of the slant main gear.  
 螺絲鎖附於斜主齒輪 φ 3.0 孔位

One-way bearing shaft  
 單向軸承套 φ 12x φ 15x41.5mm

One-way bearing collar  
 單向軸承外環 φ 8x φ 23x11.6mm

Spacer  
 700 單向墊片 φ 18x φ 22.7x0.7mm

Apply grease  
 塗上潤滑油

One-way bearing mount  
 單向軸承下座  
 φ 21x φ 6.5x33.1mm

Bearing  
 軸承 φ 15x φ 21x4mm

One-way bearing  
 單向軸承 φ 15x φ 23x11mm

Please note the direction of bearing.  
 請注意軸承方向



M1 Autorotation tail drive gear set  
 M1 尾驅動主齒輪 104T

Socket screw  
 圓頭內六角螺絲 M2.5x8mm

CAUTION  
 注意

Already assembled by Factory. Before flying, please check if the screws are fixed with glue.  
 原裝組裝完成品，每一次飛行前請先確認螺絲是否已上膠不會鬆動。

Before tightening the screw, please rotate the bearing and check the concentricity of the bearing in order to have the screw firmly secured, to avoid the bearing stuck or heavy load at one side and cause slip.

上緊螺絲前需試轉動確認軸承同心度良好後，才能將螺絲平均鎖緊，以避免造成卡死或單向重負載可能產生的打滑。

Apply a little amount of T43 thread lock when fixing a metal part.  
螺絲鎖附於金屬件請使用適量T43(螺絲膠)

When tightening the main blade fixing screw, please tighten it firmly, but not over tighten, or it may cause the damage of main blade holder and result in danger.  
鎖緊主旋翼螺絲須注意適當緊度即可，過緊可能導致主旋翼夾座受損，飛行意外發生。

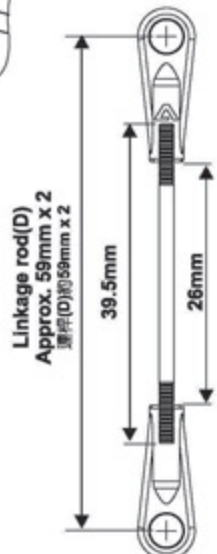
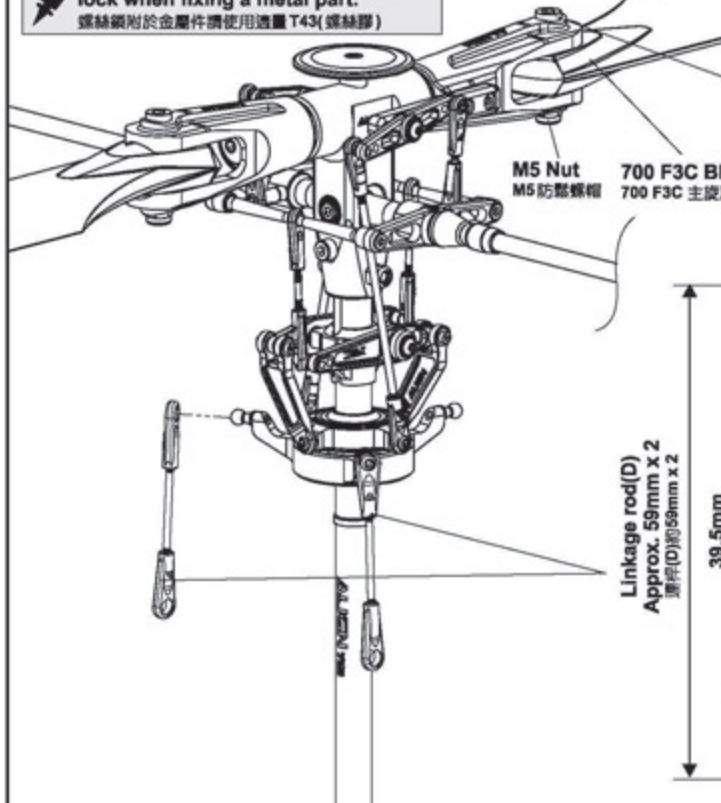

**700HH7A**

**Main Blade Fixing Screw**  
鎖主旋翼用螺絲

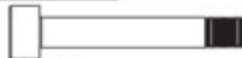

**Socket collar screw**  
圓頭內六角輪套螺絲 (M5x32mm) x 2



**M5 Nut**  
M5 防鬆螺帽 x 2

**700HB14**

**Socket collar screw**  
圓頭內六角輪套螺絲 (M4x27mm) x 1



**M4 Nut**  
M4 防鬆螺帽 x 1

**700HH10A**

**Main shaft spacer(1)**  
主軸墊片(1)  
( $\phi 12x \phi 16x1mm$ ) x 1

**Spare part: Main shaft spacer(0.8)**  
備品：主軸墊片(0.8)  
( $\phi 12x \phi 16x0.8mm$ ) x 1

**Spare part: Main shaft spacer(1.2)**  
備品：主軸墊片(1.2)  
( $\phi 12x \phi 16x1.2mm$ ) x 1

**Spare part: Main shaft spacer(0.5)**  
備品：主軸墊片(0.5)  
( $\phi 12x \phi 16x0.5mm$ ) x 1

**Spare part :**  
Main shaft spacer(1.2)  
Main shaft spacer(0.8)  
Main shaft spacer(0.5)  
備品：  
主軸墊片(1.2)  $\phi 12x \phi 16x1.2mm$   
主軸墊片(0.8)  $\phi 12x \phi 16x0.8mm$   
主軸墊片(0.5)  $\phi 12x \phi 16x0.5mm$

**Standard Equipment :**  
Main shaft spacer(1)  
標準品：主軸墊片(1)  
 $\phi 12x \phi 16x1mm$

**700HZ8**

**Linkage rod(D)**  
連桿(D) ( $\phi 1.96x39.5mm$ ) x 2



**700HZ8A**

**Ball link**  
連桿頭 x 4

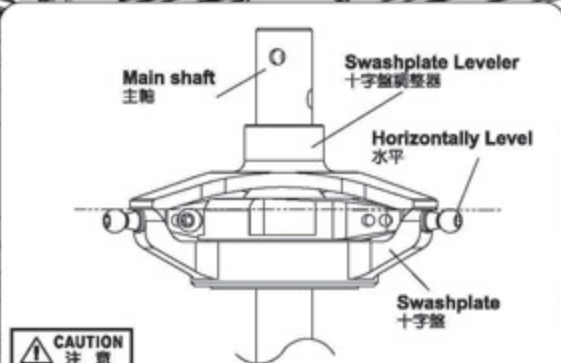
**CAUTION**  
注意

Suggest to use the swashplate leveler to calibrate swashplate. Adjust the length of servo linkage rod to make sure the swashplate is leveled before start setting up 3GX to ensure 3GX provides the best performance.  
建議使用十字盤調整器校正十字盤，調整伺服器連桿長度，確保十字盤達到水平狀態，再進行基本機體設定，以確保飛行性能達到最佳效果。

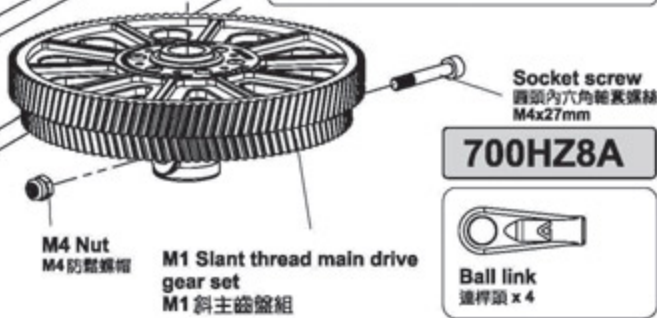

The lower edge of main gear need to be lined up with lower edge of pinion gear. This will ensure smooth meshing, and avoid interference between pinion's base and main gear which can lead to unusual wear.  
馬達齒下緣必須與主齒輪下緣水平切齊，如此才能確保齒輪傳動順暢，避免馬達主齒輪根部與新型斜主齒輪產生異常干涉磨損。



**Washer**  
華司  $\phi 6x \phi 9x0.6mm$

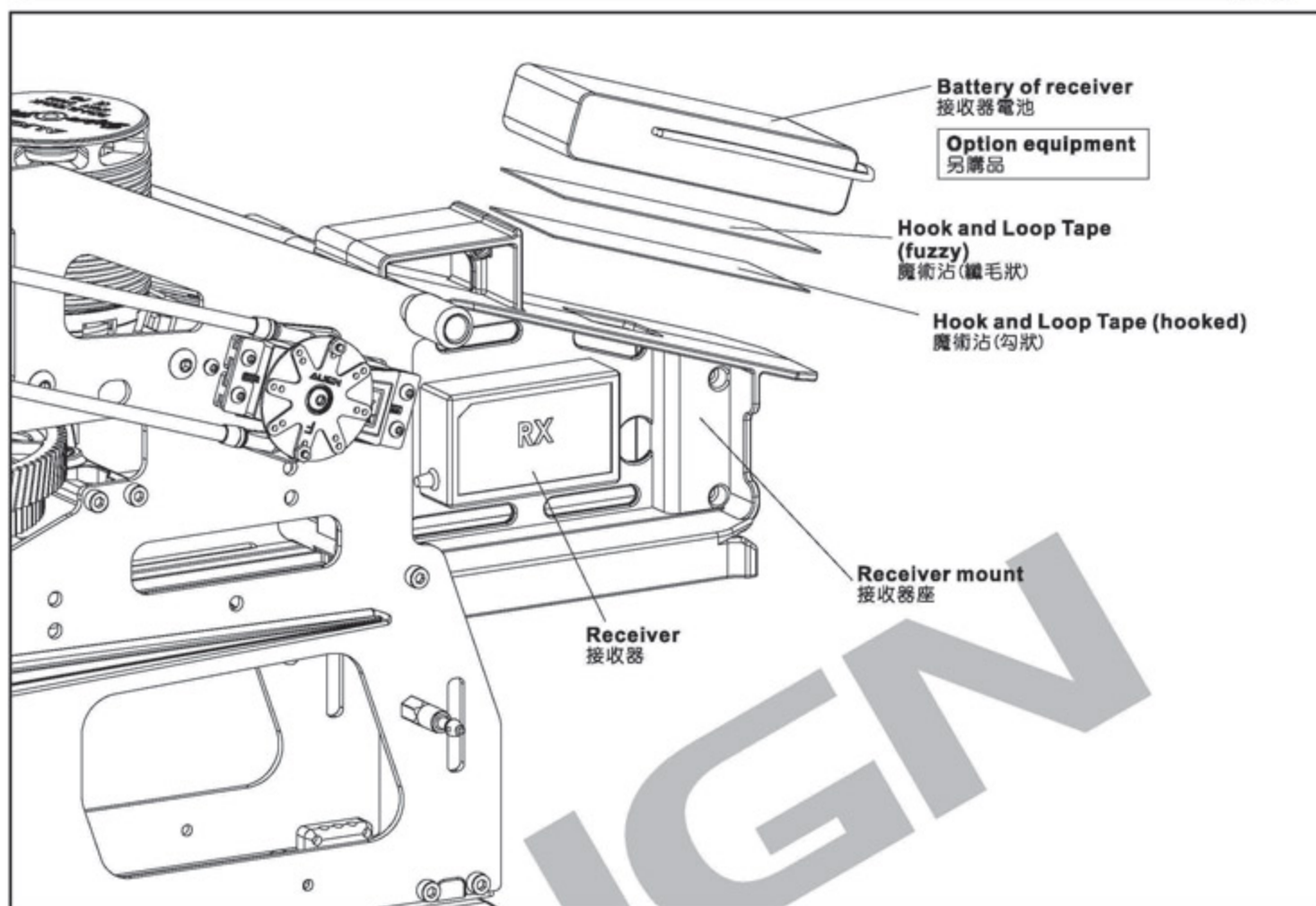

1. Consult the following diagram for GP900 installation direction. GP900 needs to be mounted flat on gyro mounting platform, away from vibration sources.
  2. Two pieces of foam mounting tape can be used if helicopter experiences vibration induced flight instability. However, if this still doesn't cure the problem, please check the helicopter mechanics and minimize mechanical vibrations, or reduce the headspeed.
  3. Please secure with genuine factory issued double sided anti-vibration mounting tape.
    - ※ If GP900 was to be mounted inverted, please enter connect anti-rorque compensation section and set it as "reverse" (STATUS LED turns red) to avoid the effect of the performance of gyro lock. (Please refer to Page 32)
1. GP900擺放方向請參照圖示，水平擺放於陀螺儀固定座，並避開震動源。
  2. 機體震動會影響陀螺儀偵測，造成飛行不穩定，可於GP900下方貼附2片泡棉減震，若仍未改善，請檢查機體排除震動或降低主旋翼轉動。
  3. 請使用原廠提供避震泡棉雙面膠固定。
    - ※ 選擇GP900面板朝下的安裝方式時，請進入設定選項中的反扭力補償設定，並將反扭力補償設為“反向”(STATUS 燈為紅燈)，以免影響陀螺儀鎖定效果。(詳細設定請參閱P.32)

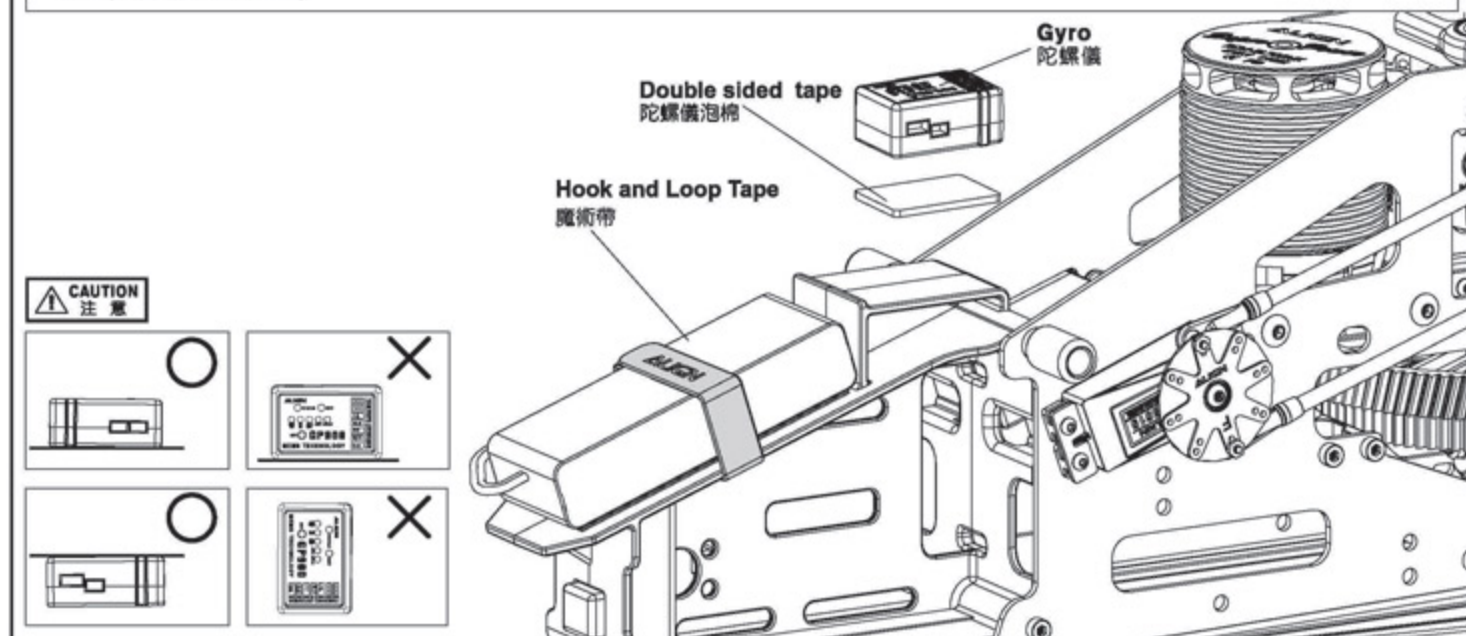

**MODE: INSERT THE BATTERY FROM THE FRONT** 方式一：電池從前方置入

**CAUTION** 注意

Please fix the 2 batteries on the battery mount evenly.  
2顆電池請平均固定於電池板上。

**CAUTION** 注意

Slide the battery mounting plate along the rail until a "click" is heard to make sure the battery mounting plate is latched.  
將電池固定板順著電池滑軌裝入至發出“喀答”聲響，使電池固定板卡入卡榫。

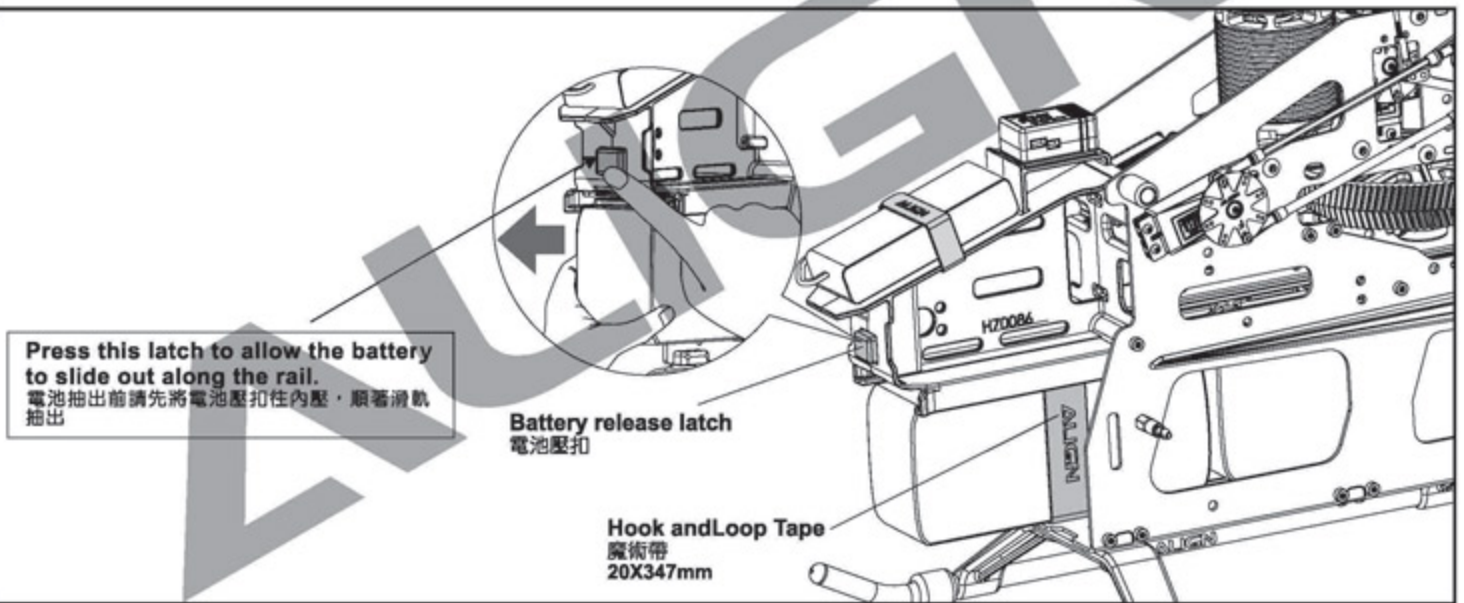
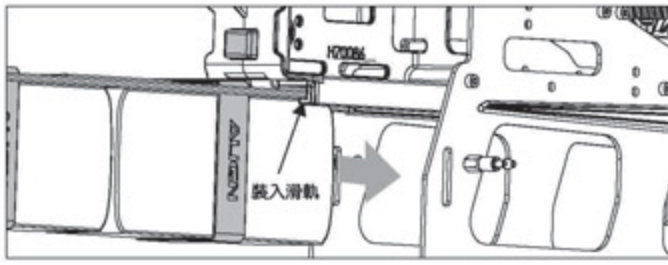
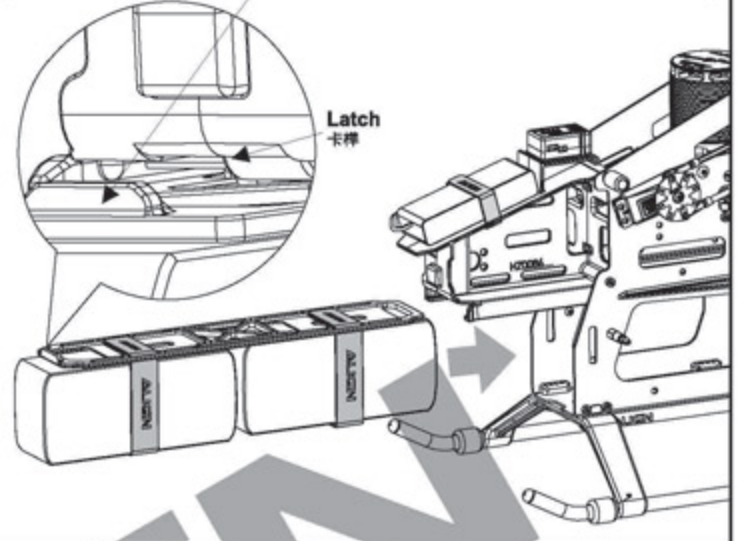
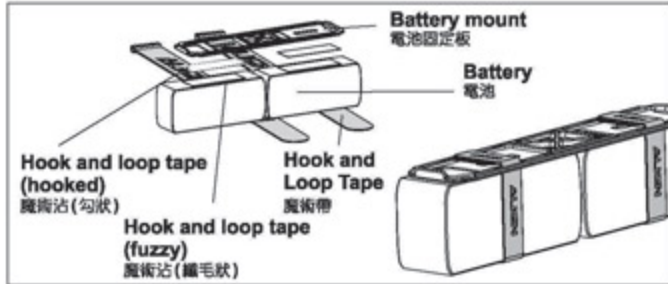

**MODE: INSERT THE BATTERY FROM THE BACK** 方式二：電池從後方置入

**STEP1. Slide along the rail**  
步驟1. 裝入滑軌

Latch side on the front  
卡榫朝向前方

**STEP2. Fasten with a hook and loop tape on the back of the battery**  
步驟2. 後方以魔術帶固定

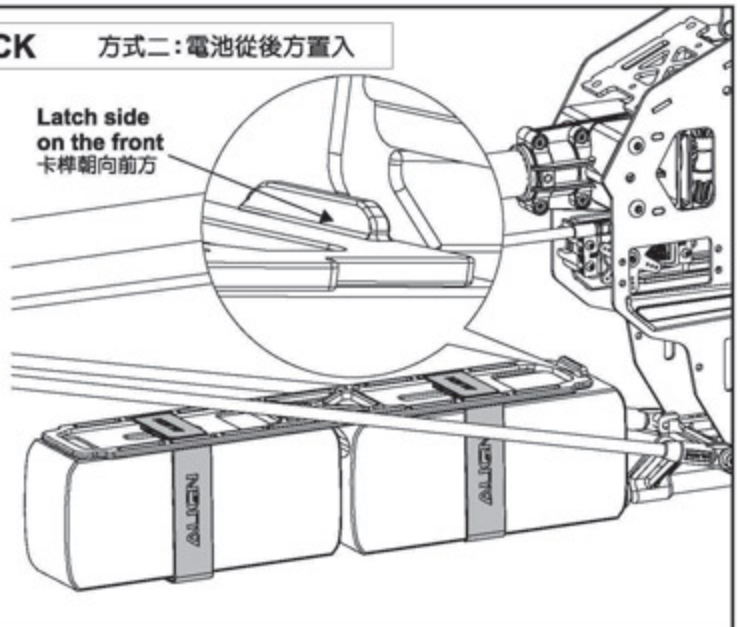
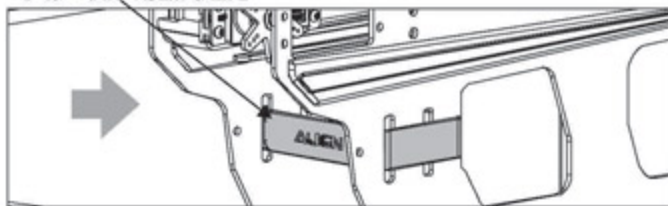
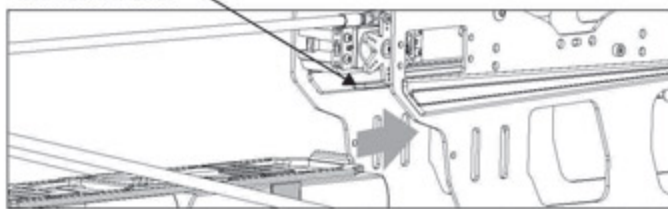

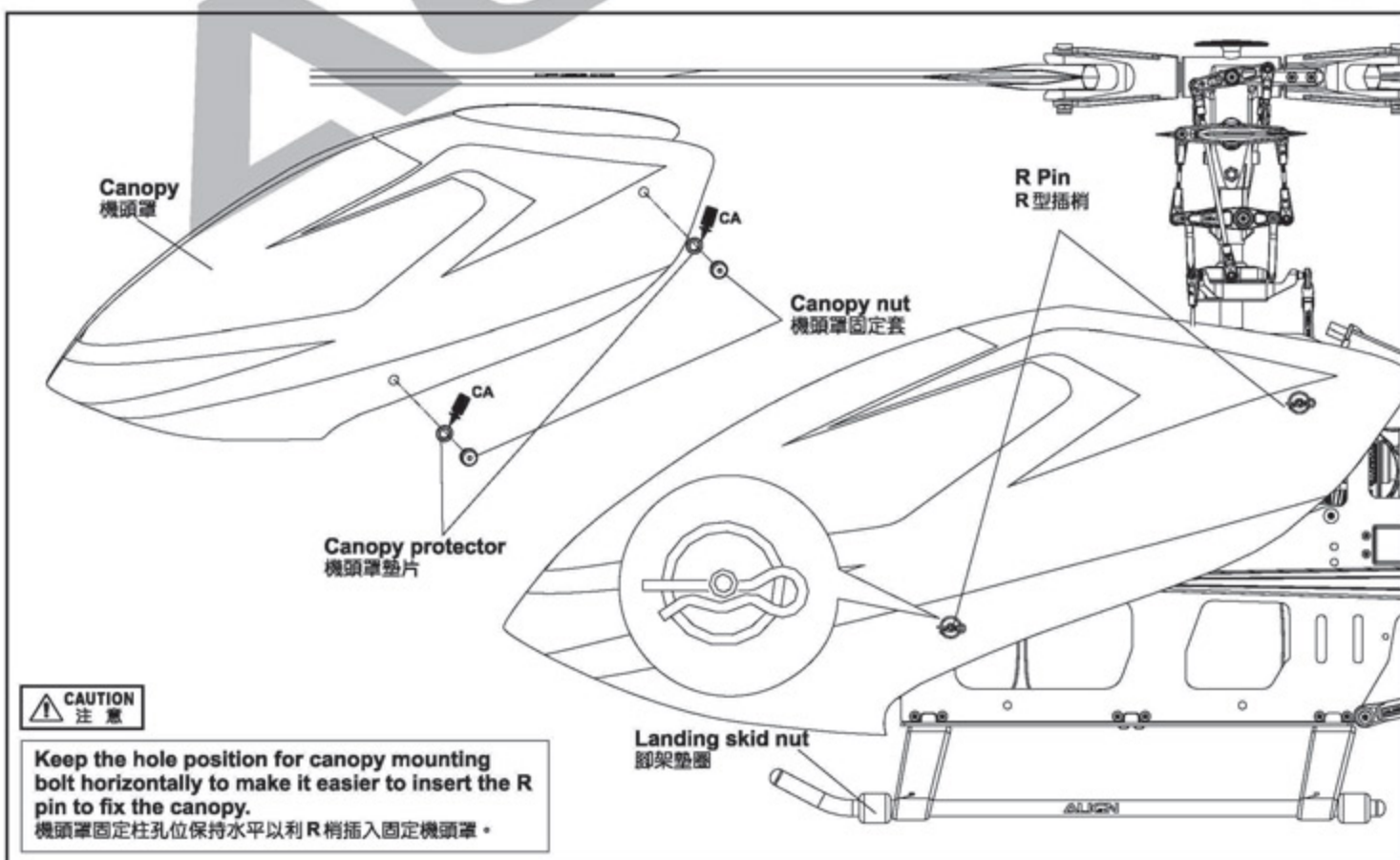
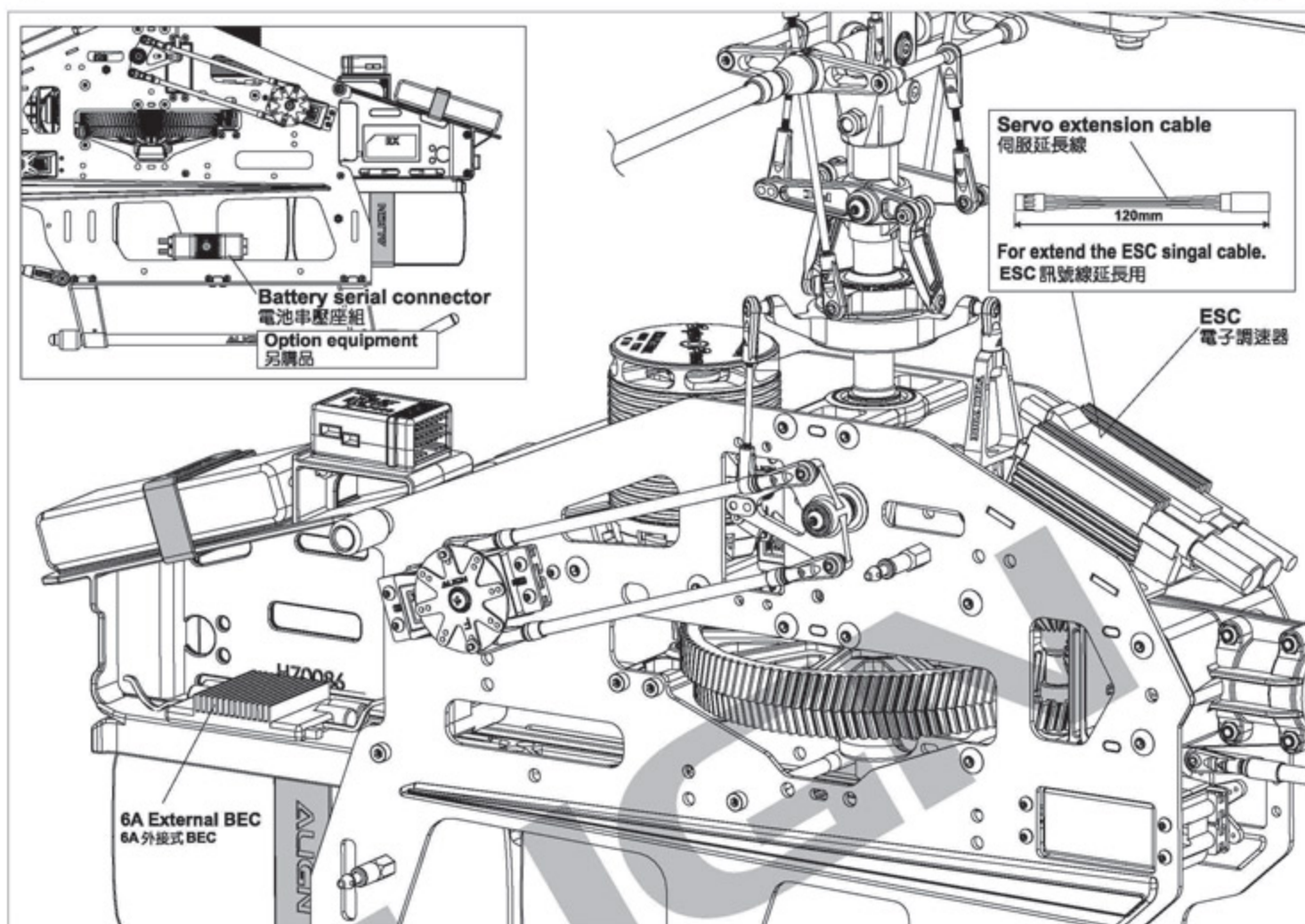

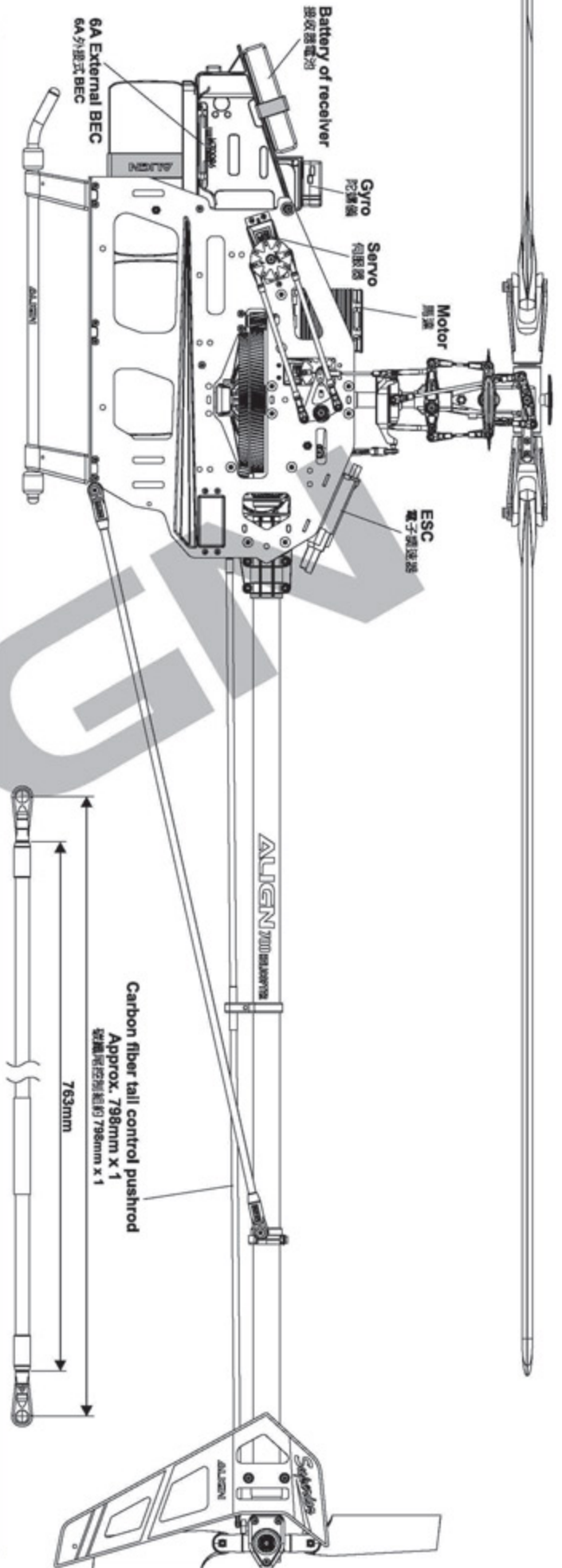

PARTS IDENTIFICATION 各部位名稱

GP900 HEAD LOCK GYRO GP900 鎖定式陀螺儀

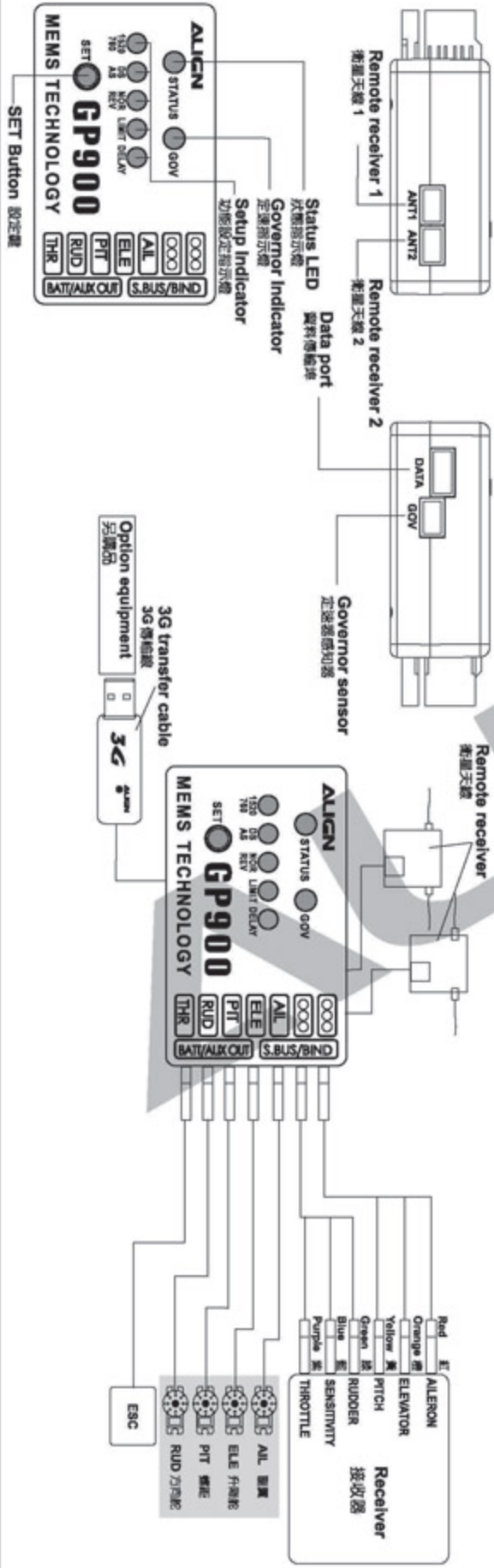



To set this option is to turn on the transmitter and connect to helicopter power. Note: For the safety, please do not connect ESC to the brushless motor before the setting in order to prevent any accident caused by the motor running during the setting.

此項設定只要開啓發射器，接上直昇機電源即可進行操作。注意：為了安全起見，設定前請先不要將無刷調速器與無刷馬達三條線接上，以免調整時啟動馬達而發生危險。

JR TRANSMITTER/SERVO JR 遙控器對應伺服器關係

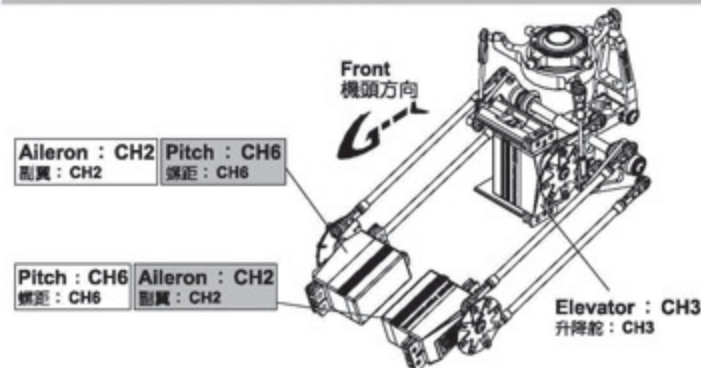

Positions of CH2、CH6 are exchangeable, After assembling as photo (Note: Set the transmitter under CCPM 120 degrees mode), pull throttle stick (pitch) upward. If one swashplate servo (or two servos) moves downward, adjust reverse switch (REV) on the transmitter to make it moves upward. If three servos move downward, adjust the travel value (+) of SWASH PIT on the transmitter to make them move upward. When the actions of Aileron and Elevator are opposite, adjust travel values of SWASH AIL and ELE.

CH2、CH6可互換配置，依圖連結後(注意：遙控器須設定於CCPM 120°十字盤模式)，將油門搖桿(Pitch)往上推，若十字盤伺服器有1個或2個往下移時，請調整遙控器的反轉開關(REV)使伺服器往上，若3個伺服器同時往下移時，請調整遙控器 SWASH PIT 行程量的正負值，使伺服器同時往上平移，副翼與前後動作相反時，同樣調整 SWASH AIL、ELE 行程量正負值。

FUTABA/HITEC TRANSMITTER/SERVO FUTABA/HITEC 遙控器對應伺服器關係

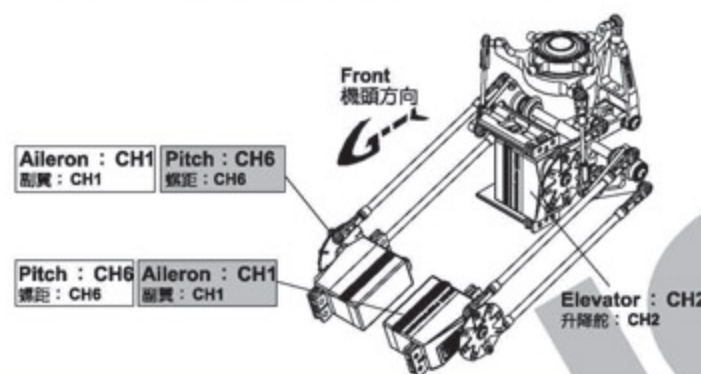

Positions of CH1、CH6 are exchangeable, After assembling as photo (Note: Set the transmitter under CCPM 120 degrees mode), pull throttle stick (pitch) upward. If one swashplate servo (or two servos) moves downward, adjust r everse switch (REV) on the transmitter to make it moves upward. If three servos move downward, adjust the travel value (+) of SWASH PIT on the transmitter to make them move upward. When the actions of Aileron and Elevator are opposite, adjust travel values of SWASH AIL and ELE.

CH1、CH6可互換配置，依圖連結後(注意：遙控器須設定於CCPM 120°十字盤模式)，將油門搖桿(Pitch)往上推，若十字盤伺服器有1個或2個往下移時，請調整遙控器的反轉開關(REV)使伺服器往上，若3個伺服器同時往下移時，請調整遙控器 SWASH PIT 行程量的正負值，使伺服器同時往上平移，副翼與前後動作相反時，同樣調整 SWASH AIL、ELE 行程量正負值。

13.ADJUSTMENTS FOR GYRO AND TAIL NEUTRAL SETTING 陀螺儀與尾翼中立點設定調整

Turn off Revolution mixing(RVMX) mode on the transmitter, then set the gain switch on the transmitter and the gyro to non-Head lock mode, or disable gain completely. After setting the transmitter, connect the helicopter power and proceed with rudder neutral point setting. Note: When connecting to the helicopter power, please do not touch tail rudder stick and the helicopter, wait for 3 seconds for gyro to enable, and the rudder servo horn should be 90 degrees to the tail servo. Tail pitch slider should be halfway on the tail output shaft. This will be the standard rudder neutral point. After completing this setting, set the gain switch back to heading lock mode, with gain at around 70%.

發射器內陀螺儀設定請關閉板軸混控模式，並將發射器上的感度開關與陀螺儀切至“非鎖定模式”或將陀螺儀感度關閉。發射器設定完成後接上直昇機電源，即可進行尾舵中立點設置。注意：當接上直昇機電源時請勿撥動尾舵搖桿或碰觸機體，待3秒陀螺儀開機完成後，尾伺服臂需與尾伺服器約成90度，尾旋翼控制組須正確置於尾橫軸約中間位置，即為標準尾舵中立點設定，設定完成後，切換至“鎖定模式”，感度設約70%左右。

TAIL NEUTRAL SETTING

尾中立點設定

After the gyro is enable and under non-Head lock mode, correct setting position of tail servo and tail pitch assembly is as photo. If the tail pitch assembly is not in the middle position, please adjust the length of rudder control rod to trim.

陀螺儀開機後，在非鎖定模式下，尾伺服器與尾 Pitch 控制組正確擺置位置。若尾 Pitch 控制組未置中時請調整尾控制連桿的長度來修正。

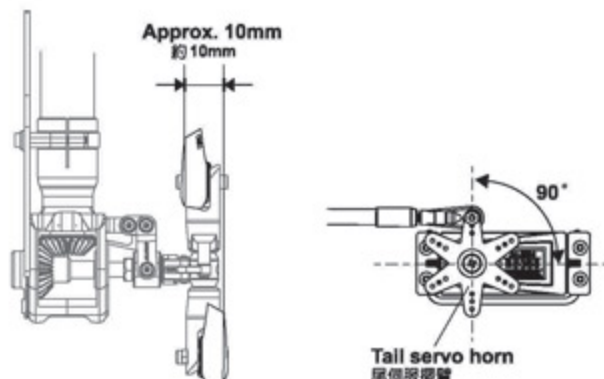

HEAD LOCK DIRECTION SETTING OF GYRO

陀螺儀鎖定方向設定

To check the head lock direction of gyro is to move the tail counterclockwise and the tail servo horn will be trimmed clockwise. If it trims in the reverse direction, please switch the gyro to "REVERSE".

陀螺儀鎖定方向確認，當手搖尾部順時鐘擺動，尾伺服臂應逆時鐘修正，反向時請切換陀螺儀上“鎖定反向”開關修正。

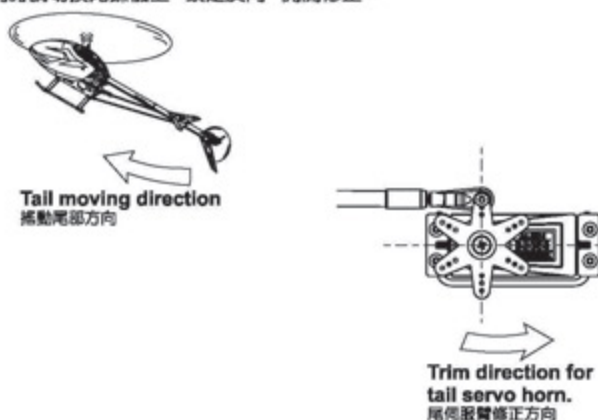

GENERAL FLIGHT 一般飛行模式

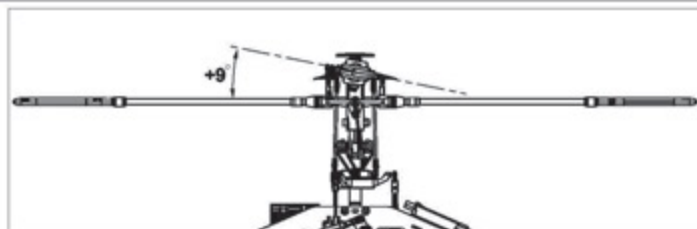

Stick position at high/Throttle 100%/Pitch+9  
搖桿高速/油門100%/Pitch+9

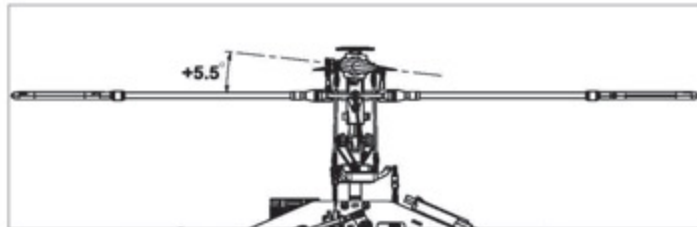

Stick position at Hovering/Throttle 70%/ Pitch+5.5  
搖桿停懸/油門70%/Pitch+5.5

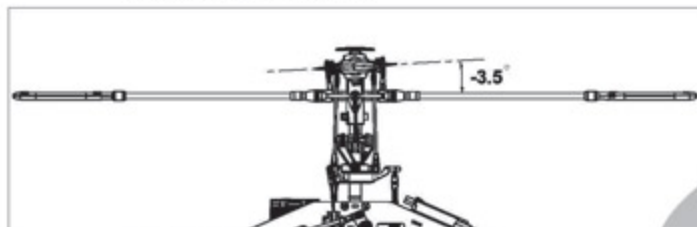

Stick position at low/Throttle 0%/Pitch-3.5  
搖桿低速/油門0%/Pitch-3.5

GENERAL FLIGHT 一般飛行模式

	Throttle 油門	Pitch 螺距
5	100% High speed 100% 高速	+9°
4	85%	
3	70% Hovering 70% 停懸	+5.5°
2	45%	
1	0% Low speed 0% 低速	-3.5°

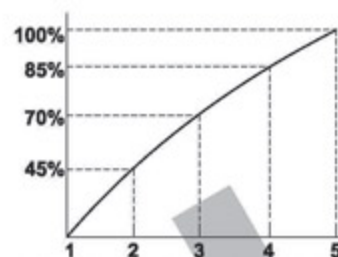

Throttle Curve (Hovering Flight)  
停懸模式油門曲線

IDLE UP FLIGHT IDLE UP 飛行模式



Stick position at high/Throttle 100%/Pitch+10  
搖桿高速/油門100%/Pitch+10

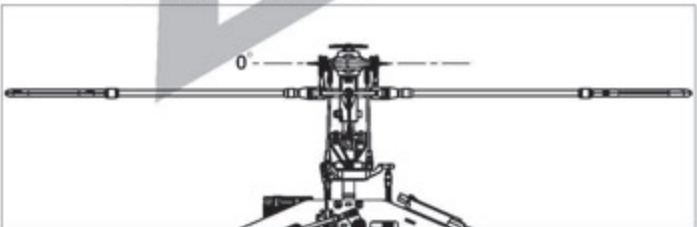

Stick position at middle/Throttle 90%/Pitch 0  
搖桿中速/油門90%/Pitch 0°

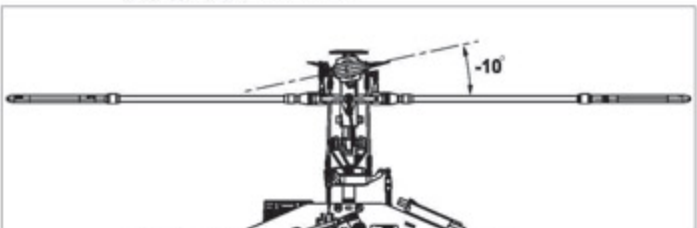

Stick position at low/Throttle 100%/Pitch-10  
搖桿低速/油門100%/Pitch-10

IDLE UP FLIGHT

	Throttle 油門	Pitch 螺距
5	100% High 100% 高	+10°
3	90% Middle 90% 中	0°
1	100% Low 100% 低	-10°

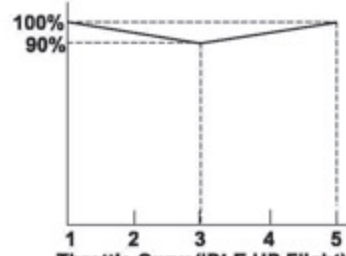

Throttle Curve (IDLE UP Flight)  
IDLE UP 飛行模式油門曲線



- CAUTION 注意**
1. Pitch range : Approx. ± 12 degrees.
  2. If the pitch is set too high, it will result in shorter flight duration and poor motor performance.
  3. Setting the throttle to provide a higher speed is preferable to increasing the pitch too high.
1. 螺距(Pitch)總行程約 ± 12°  
2. 過大螺距設定，會導致動力與飛行時間降低。  
3. 動力提升以較高轉速的設定方式，優於螺距調大的設定。

- Input voltage: DC 7.4V 2cell Lithium battery
- Output voltage: DC 5.8V
- Max. Continuous Current: 6A
- Integrated power switch and voltage indicator meter
- Utilizes a linear design, resulting in no interference to the receiver.
- Including a 5A 5.1V two-way step-down Voltage Regulator
- Size: 60x34x15mm
- Weight: 31g(Including wire set)

- 輸入電壓: DC 7.4V 2CELL鋰電
- 輸出電壓: DC 5.8V
- 最大連續輸出電流: 6安培
- 具電源切換開關與電壓指示燈功能
- 採線性設計，無干擾接收機的缺點
- 附5A 5.1V雙向降壓器
- 尺寸: 60x34x15mm
- 重量: 31g(含線組)

#### WIRING ILLUSTRATION:

Connect a 5.1V two-way step-down voltage regulator between the gyro and the rudder servo.

接線示意圖：

5.1V 雙向降壓器連接於陀螺儀與尾舵伺服器之間。

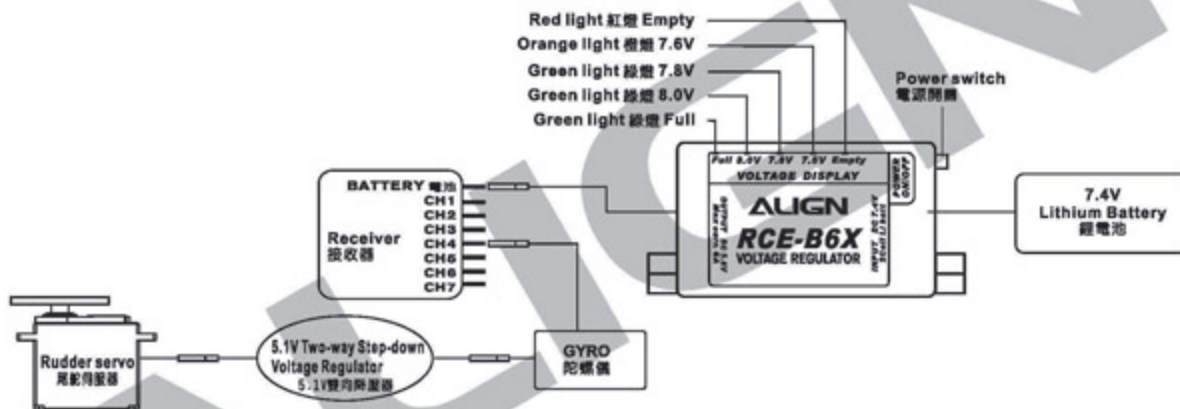

#### Instruction:

1. Auto-detecting voltage meter display lights. If the entire five-light array is illuminated, the battery is fully charged. When the voltage drops below 7.6V, the three green lights will be turned off. Use caution, the battery can only be safely used for a single flight. When only the red light is on, the battery voltage is drained, and must be fully recharged before use. Do not attempt to operate the model during this condition!
  2. Some servos such as Futaba servo models 9241, 9251, 9253, 9254, 9255, 9256 and other digital servos are not capable of handling 6V. Please connect a 5.1V two-way step-down voltage regulator to avoid the servo damaged. If you are using a servo that can accept 6V input, the regulator is not required.
  3. When using a speed controller with BEC output, you must remove the red wire of BEC output on the speed controller.
  4. If the receiver does not have enough channels or an available socket, you can use a Y-type servo harness to share any channel with an existing connection.
1. 本產品具電壓指示功能，當接入充飽的電池時五顆指示燈全亮，表示電池在Full電量充足狀態下；使用中當電壓降低至7.6V時(3顆綠燈熄滅)，尚可完成單趟飛行即須對電池充電或更換新電池；而如果僅亮紅燈時表示Empty電量不足，不應該再使用囉！
  2. 部份的伺服器如：Futaba 9241.9251.9253.9254.9255.9256等，此類型的伺服器不適合於較高的電壓下操作，所以使用此類型的伺服器時請另外加裝5.1V降壓器，避免伺服器損壞；規格標示准許6V輸入的伺服器則不須使用降壓器。
  3. 使用具BEC輸出之調速器時，必須將調速器BEC輸出的紅色線拆除！
  4. 若接收機已無多餘的電源插孔時，可利用一條伺服Y型連接線，接到接收機的任一通道，再將外接BEC與拆下的通道一同接在Y型線上。

**NOTE:** When fixing the wire, please do not over tighten to avoid the connector come off or the wire broken when the helicopter rotates (vibration); do not operate in rain or moisture environment to avoid the electric parts short circuit and damaged.





注意：固定線組時勿將各線組纏緊，以免直昇機旋轉時因震動造成接頭鬆脫或斷線；避免在雨中或潮濕的環境下使用，以免造成零件短路而損壞。

## FEATURES 產品特色

- MEMS** Utilizes MEMS gyro sensors, which feature small footprint, high reliability, and excellent stability.  
採用 MEMS ( Micro Electro Mechanical Systems ) 微機電系統技術感測器，具有體積小，可靠性高，穩定性佳的優點。
- 12bit** Sensor with 12 bit ultra high resolution, resulting in highly precise controls.  
感測器 12 位元超高解析度，控制細膩精準。
- Supports Spektrum and JR satellite receivers.**  
支援 SPEKTRUM 與 JR 衛星天線。
- S.BUS** Supports Futaba S.Bus architecture.  
支援 Futaba S.BUS 功能。
- Software upgradable through PC interface adapter.**  
具備可升級程式化介面，可透過傳輸線更新軟體。
- Stable** Highly sensitive gyroscopic sensors combined with advanced control detection routine providing higher hovering and aerobatic stability.  
高感度陀螺感測器及先進環路設計，可提供更佳的靜態及動態穩定性。
- GOV** Built in speed governor function.  
內建定速器功能。
- 3.5V-8.4V** Capable to operate between 3.5V to 8.4V, compatible with high voltage servos.  
適用電壓 3.5V ~ 8.4V，支援高電壓伺服器。
- 11g** Small footprint, light weight, minimalists and reliable design.  
體積小、重量輕，構造簡單可靠，提供操控者高性能的飛行樂趣。
- RoHS** RoHS certified.  
符合 RoHS 限用規章。

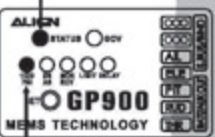
## GP900 HEAD LOCK GYRO SETUP INDICATORS GP900 鎖式陀螺儀功能設定指示燈說明

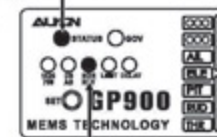
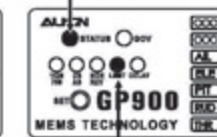
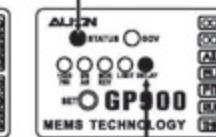
## T-REX700 STANDARD SETTING T-REX700 標準設定

STEP 1 步驟 1	STEP 2 步驟 2	STEP 3 步驟 3	STEP 4 步驟 4	STEP 5 步驟 5	STEP 6 步驟 6
<b>Green: 1520 <math>\mu</math> s standard band</b> 設定為綠燈：1520 $\mu$ s 寬頻	<b>Green: Digital Servo</b> 設定為綠燈：數位伺服器	<b>Green: Normal rotation.</b> Red: Reverse rotation. 設定為綠燈：NOR 正轉 設定為紅燈：REV 反轉	<b>The STATUS LED color does not indicate any setting here.</b> 此項設定 "STATUS" 燈號不代表任何設定值。	<b>Green: Suitable for T-REX 700 or other medium to large helicopters</b> 設定綠燈：適用 T-REX700 直昇機。	<b>Green: right side up mounting.</b> Red: upside down mounting 綠燈：GP900 正裝 紅燈：GP900 反裝
					
<b>Standard/Narrow band setting</b> 寬頻 / 窄頻設定	<b>DS/AS Setting</b> 數位 / 類比設定	<b>Servo NOR/REV Setting</b> 伺服器正 / 反轉設定	<b>Travel Limit Setting</b> 行程量設定	<b>Helicopter mode / DELAY Setting</b> 中小型直昇機模式 / DELAY 設定	<b>Anti-torque compensation direction setting</b> 反扭力補償正反向設定

Setting type 設定項目	1520/760 $\mu$ s	DS/AS	NOR / REV	LIMIT	Helicopter mode / DELAY 直昇機模式 / DELAY	Anti-torque compensation 反扭力補償正反向
"STATUS" green "STATUS" 綠燈	▲ Standard 1520 $\mu$ s Servo ▲ 標準 1520 $\mu$ s 伺服器	▲ Digital servo ▲ DS 數位伺服器	▲ Normal rotation ▲ NOR 正轉	Left(Right) Travel limit 左(右)行程量	Medium/ large heli, suitable for T-REX 500/600/700 中型 / 大型直昇機 適用 T-REX 500/600/700	Right side up mounting: Installed with GP900 label facing up 正裝：安裝時 GP900 面板朝上
"STATUS" red "STATUS" 紅燈	Narrow band 760 $\mu$ s Servo 窄頻 760 $\mu$ s 伺服器	Analog Servo AS 類比伺服器	Reverse rotation REV 反轉	Right(Left) Travel limit 右(左)行程量	Mini/ Micro heli, suitable for T-REX250/450 小型 / 迷你型電直 適用 T-REX 250/450	Upside down mounting: Installed with GP900 label facing down 反裝：安裝時 GP900 面板朝下
Setting instruction 設定方式說明	Please refer to point 1 in Rudder Gyro Setup (page 29) 請參照尾舵陀螺儀設定 第一項 (第 29 頁)	Please refer to point 2 in Rudder Gyro Setup (page 30) 請參照尾舵陀螺儀設定 第二項 (第 30 頁)	Please refer to point 4 in Rudder Gyro Setup (page 31) 請參照尾舵陀螺儀設定 第四項 (第 31 頁)	Please refer to point 5 in Rudder Gyro Setup (page 31) 請參照尾舵陀螺儀設定 第五項 (第 31 頁)	Please refer to point 6 in Rudder Gyro Setup (page 31) 請參照尾舵陀螺儀設定 第六項 (第 31 頁)	Please refer to point 7 in Rudder Gyro Setup (page 32) 請參照尾舵陀螺儀設定 第七項 (第 32 頁)

NOTE: 1. "▲" "Default setting."  
註：1. "▲" 表示出廠設定值。

2. Wrong heli mode will affect the performance of gyro. Do not fly before the complete setting.  
2. 錯誤的直昇機模式將影響陀螺儀性能，未完成設定前請勿飛行。

**METHOD 1: STANDARD RECEIVER CONNECTIVITY METHOD** 方式一：傳統接收器接線法

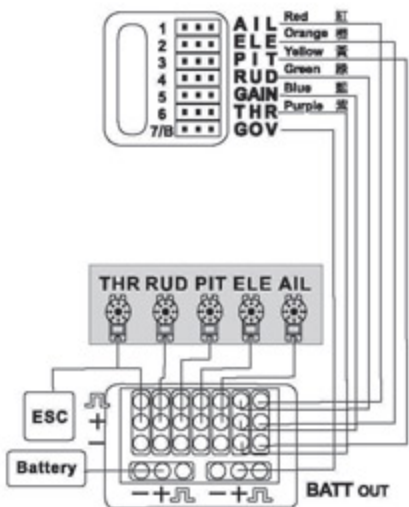

1. Connect all wires as shown in diagram. Receiver and GP900 wires are color coded to distinguish the different connection channels. Care should be taken to ensure proper wire color to channel connection.
  2. While using the speed controller that not including BEC, you need to connect the BEC power with GP900 "BATT" port.
  3. Receiver power is achieved by connecting the Gp900 "S.BUS/BIND" port to the ch7 or BATT port on receiver using supplied signal wire.
  4. GP900 has built in speed governor function which can be utilized by purchasing the optional speed sensor. Governor setting is done through channel 7 on the receiver.
1. 請依照圖示進行接線，接收器與 GP900 的接線使用不同的顏色來區分不同的通道，接線時請注意各顏色所對應的通道。  
 2. 使用無 BEC 輸出的調速器時，須額外由 GP900 的 "BATT" 孔位接入 BEC 電源。  
 3. 接收器電源請以隨附的訊號線由 GP900 的 "S.BUS/BIND" 孔位接至第七通道或 BATT 通道。  
 4. GP900 內建定速器功能，可另購定速器感知器使用，轉速設定由接收器的第七通道設定。

**METHOD 2: FUTABA S.BUS CONNECTIVITY METHOD** 方式二：FUTABA S.BUS 接線法

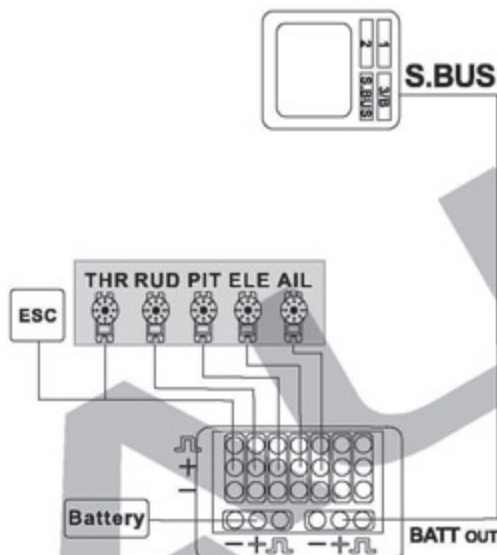

1. For Futaba S.BUS receivers, connect wires as shown in diagram.
  2. While using the speed controller that not including BEC, you need to connect the BEC power with GP900 "BATT" port.
  3. Receiver power is supplied through S.BUS signal wire connected to GP900's "S.BUS/BIND" port.
  4. The default channel/function mapping when using S.BUS are:  
 (1)AIL (2)ELE (3)THR (4)RUD (5)GAIN (6)PIT (7)GOV
1. 與 S.BUS 功能的 Futaba 接收器，請依照圖示進行接線。  
 2. 使用無 BEC 輸出的調速器時，須額外由 GP900 的 "BATT" 孔位接入 BEC 電源。  
 3. 接收器電源共同由 S.BUS 訊號線接至 GP900 的 "S.BUS/BIND" 孔位。  
 4. 使用 S.BUS 功能時，內部通道已指定為：  
 (1)AIL (2)ELE (3)THR (4)RUD (5)GAIN (6)PIT (7)GOV

**CAUTION**  
注意

If channel 3 is set as PIT and channel 6 set as THR on transmitter, such as 8FG, 12Z, 14MZ, etc, please reprogram the transmitter to utilize channel 3 as THR and channel 6 as PIT. 若所使用的遙控器內部指定 (3) 通道為 PIT (6) 通道為 THR 時，例如 8FG、12Z、14MZ 等，請更改遙控器上的設定為 (3) 通道 THR (6) 通道 PIT。

5. GP900 has built in speed governor function which can be utilized by purchasing the optional speed sensor. Governor setting is done through channel 7 on the receiver.
5. GP900 內建定速器功能，可另購定速器感知器使用，轉速設定由接收器的第七通道設定。

**METHOD 3: JR/SPEKTRUM SATELLITE CONNECTIVITY METHOD** 方式三：JR/SPEKTRUM 衛星天線接線法

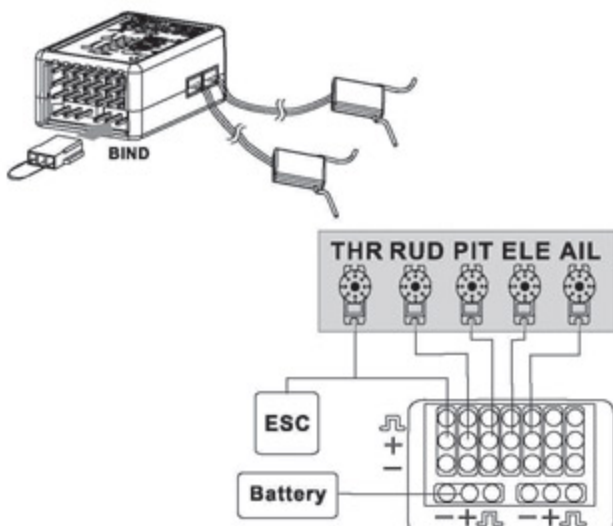

1. For JR or Spektrum satellite receivers, connect wires as shown in diagram.
2. While using the speed controller that not including BEC, you need to connect the BEC power with GP900 "BATT" port.
3. GP900 has built in speed governor function which can be utilized by purchasing the optional speed sensor. Governor setting is done through channel 7 on the receiver. Channel 5/GEAR controls RPM of speed governor, channel 7/AUX2 controls rudder gyro gain. For radios with less than 6 channels, please use the standard receiver connectivity method.
4. For radios with less than 6 channels, channel 5/GEAR is used for rudder gyro gain. Speed governor cannot be used. For safety concern, two satellite receives should be used, with each antenna perpendicular (90 degrees) from each other. A satellite receiver should be installed on each side of the frame, separate by minimum distance of 5cm.
5. Should both satellite receivers loose connectivity during flight, LED1 ~ LED5 will flash continuously as warning. A single power cycle of the system will not clear this error. The system need to be power cycled the second time to reset.
6. default channel/function mapping when using satellite receiver are:  
 (1) THR (2) AIL 3) ELE (4) RUD (5) GOV (6) PIT (7) GAIN



1. Do not mix satellite receivers of different makes.
2. Even under correct startup sequence, if transmitter is powered off first, LED1~LED5 will also flash. Thus the receiver should always be powered off before the transmitter.
3. 3GX supports satellite receiver models currently available on the market. Should new receiver version comes out with compatibility issues, firmware will be updated to resolve any incompatibility that may arise.

1. 不同廠牌的衛星天線請勿交叉對頻。
2. 正常開機的情況下，如果先關發射機，也會發生 LED1~LED5 持續閃爍情況，所以請養成先關接收機，再關發射機的良好習慣。
3. 如有新型號衛星天線產生不相容情形，將以韌體更新方式解決。

1. 請依照圖示進行接線，GP900 支援 Spektrum 與 JR 系統衛星天線。
2. 使用無 BEC 輸出的調速器時，須額外由 GP900 的 "BATT" 孔位接入 BEC 電源。
3. GP900 內建定速器功能，可另購定速器感知器使用。七動及七動以上遙控器 (5)GEAR 控制定速器轉速，(7)AUX2 控制尾舵陀螺儀感度。六動以下遙控器請使用傳統接線方式。
4. 為安全起見，請盡量安裝兩個衛星天線，兩個衛星天線角度除必須呈 90 度之外，且須安裝於機身兩側，相隔至少 5 公分以上。
5. 如果飛行途中有兩個衛星天線同時失連的情形，LED1~LED5 會持續閃爍警告，在此情形下就算重新開機，LED1~LED5 會持續閃爍而無法開機，必須再重新開機一次，才可正常運作。
6. 使用衛星天線接線時，內部通道已指定為：  
(1)THR (2)AIL (3)ELE (4)RUD (5)GOV (6)PIT (7)GAIN

### FAILSAFE(LAST POSITION HOLD) 失控保護(保留最後指令)：

When helicopter lost connectivity with your radio under this setting, all channels will hold at the last command position, except throttle channel which goes to a preset position.

1. Push throttle stick to the desired fail safe position.
2. Plug the binding plug into GP900's BIND port, and perform radio binding steps.
3. After successful binding, do not power off the GP900, unplug the binding plug and allow GP900 to enter initializing process. The last position hold function will be active after the GP900 initializes.
4. Test Method: Power off transmitter. The throttle channel should move to preset position, while all other channels should hold in their last position.

在此模式下，若您的直昇機與遙控器失連，除油門頻道為預設位置，其餘頻道皆為最後指令位置。

1. 將油門搖桿放置於您所需要的預設安全位置
2. 將對頻接頭插在 GP900 的 BIND 插座，執行與遙控器的對頻動作。
3. 與遙控器完成對頻動作後，不要關閉 GP900 電源，先將對頻接頭拔除，GP900 會進入開機狀態，待 GP900 開機完成後，即完成保留最後指令設定。
4. 測試方法：將遙控器關機，除了油門頻道為預設安全位置外，其餘頻道都為失連前的最後指令位置。

### FAILSAFE (PRE-SET POSITION HOLD) 失控保護(回復預設值)：

When helicopter lost connectivity with your radio under this setting, all channels will move to the pre-set position.

1. Plug the binding plug into GP900's BIND port, and power up the GP900. After the rapid flash of satellite's LEDs, pull the binding plug off.
2. Power up radio transmitter, and perform radio binding steps. After radio is bound, LED on the satellite antennas will end the rapid flash, following by slower flash.
3. Move the transmitter sticks to the desired failsafe position while the LED is flashing in slower mode.
4. Satellite antenna's LED will lit up after 5 seconds, and GP 900 goes through initializing process. The failsafe position will be set after the GP900 initializes.
5. Test Method: Power off transmitter, and all channels should move to the pre-set failsafe position.

在此模式下，若您的直昇機與遙控器失連，所有頻道為預設安全位置。

1. 將對頻接頭插在 GP900 的 BIND 插座，先開啟 GP900 電源，待衛星天線上 LED 快速閃爍後，將對頻接頭拔除。
2. 開啟遙控器電源，執行與遙控器的對頻動作，對頻完成瞬間，衛星天線上 LED 會由快速閃爍狀態熄滅，之後再亮起改為慢速閃爍。
3. 在慢速閃爍狀態時，將遙控器上的所有搖桿放置於您所需要的預設安全位置。
4. 5 秒後衛星天線 LED 燈為恆亮，GP900 進入開機狀態，待 GP900 開機完成後，即完成失控保護設定。
5. 測試方法：將遙控器關機，所有頻道為預設安全位置。

### RUDDER GYRO SETUP 尾舵陀螺儀設定

Push and hold the SET button for 2 seconds to enter the rudder gyro setup mode.  
If your transmitter has the following settings, please disable it or set the value to zero.  
於待機狀態下持按 "SET" 鍵 2 秒進入尾舵陀螺儀設定。

如果您的遙控器有下列功能時，請設定為關閉 (OFF) 或數值設定為零。

- ATS
- Pilot authority mixing
- Throttle to rudder mixing
- Rudder to gyro mixing
- Pitch to rudder mixing
- Revolution mixing



GP900 rudder gyro has the factory setting of 1520  $\mu$ s and DS digital servo. Double check your servospec and change the gyro setting as needed to avoid damages to the servo.

GP900 尾舵陀螺儀出廠設定值為：1520  $\mu$ s 寬頻與 DS 數位伺服器模式，安裝時請確認您的伺服器規格，避免設定值不同而造成伺服器損壞。

### 1. 1520 $\mu$ S (STANDARD) OR 760 $\mu$ S (NARROW BAND) SERVO FRAME RATE SETUP 1520 $\mu$ s (標準) 或 760 $\mu$ s (窄頻) 伺服器設定

GP900 is compatible with both the 760  $\mu$ s narrow frame rate servos (such as Futaba S9256, S9251, BLS251), as well as the standard 1520  $\mu$ s frame rate servos (most others). Proper frame rate must be selected based on your servo's specifications. To enter the setup mode : Press and hold the SET button for 2 seconds until STATUS LED flashes. The 1520/760 LED will light up indicating servo frame rate setup mode. Push the transmitter rudder stick left or right to select the frame rate. For example, if rudder is pushed to the left (or right) and STATUS LED turns green, the frame rate is set to 1520  $\mu$ s. To set it to 760  $\mu$ s, the rudder stick need to be pushed from the center to the opposing end 3 times for the STATUS LED to turn red, indicating frame rate set to 760  $\mu$ s.

GP900 panel : Each setting value is labeled on the 3G flybarless control unit with either green or red lettering, which corresponds to the STATUS LED color. Subsequent setup mode is entered by a single press of the SET button. Setup mode will exit if no activity is detected in 10 seconds.

GP900 相容兩種波寬控制系統，若您使用的伺服器屬於 760  $\mu$ s 系統（如 Futaba S9256、S9251、BLS251），則必須將 GP900 設定於 760 的模式，其他未標示 760  $\mu$ s 規格的伺服器，一般皆為 1520  $\mu$ s 系統，須設定為 1520 的模式。

進入功能設定模式：持按面板上的 "SET" 設定鍵約 2 秒，此時 "STATUS" 狀態指示燈會開始閃爍，且 "1520/760" 的功能設定指示燈會亮起，表示進入標準／窄頻伺服器選項，利用遙控器方向舵搖桿的左右方向來選擇設定值，例如方向舵搖桿 往左（或右）時，"STATUS" 指示燈為綠色，表示設定值為 1520  $\mu$ s 系統；若要設定為窄頻 760  $\mu$ s 系統時，必須將搖桿由中立點往相反方向連續撥動 3 次，使 "STATUS" 指示燈亮紅色，才會進入 760  $\mu$ s 系統。

GP900 的面板：標識上已使用綠／紅色的字體提示 "STATUS" 燈色所代表的設定值。設定完成後按 "SET" 鍵一次可進入下一個設定，或是 10 秒內不做任何設定，系統會自動離開設定模式。

Green LED : 1520  $\mu$ s standard band  
Red LED : 760  $\mu$ s narrow band  
綠燈：1520  $\mu$ s 寬頻伺服器  
紅燈：760  $\mu$ s 窄頻伺服器

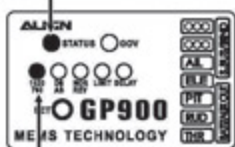

Standard/Narrow band mode  
寬頻/窄頻模式

Select by moving the rudder stick left and right  
左右撥動方向舵選擇



## 2. DS (DIGITAL) / AS (ANALOG) SERVO SELECTION

DS 數位 / AS 類比伺服器選擇

There is a direct correlation between servos' speed to gyro's performance. Faster servos are able to execute commands from the gyro at faster and higher precision. Due to the high performance gyro sensors used in the GP900, premium high speed digital rudder servos are mandatory for optimal tail performance.

Setup method : Press and hold the SET button for 2 seconds to enter the setup mode, then press the SET button to select DS/AS setup mode, as indicated by the lighting of DS/AS LED. Using the transmitter's rudder stick, select either digital servo DS mode (STATUS LED is green), or analog servo AS mode (STATUS LED is red).

伺服器動作速度與陀螺儀的性能，伺服器動作愈快，就能立即反應陀螺儀送出的指令，發揮快速精準的效能；由於 GP900 具有相當快速的反應時間與靈敏度，所以建議您搭配高速型數位伺服器，以獲得最佳效能。

設定方式：持按 "SET" 鍵 2 秒進入功能設定模式，再按 "SET" 鍵選擇 DS / AS 選項，( DS / AS 指示燈亮起 )，利用方向舵搖桿選擇數位 DS ( STATUS 為綠燈 ) 或類比 AS ( STATUS 為紅燈 ) 伺服器。

Green LED : DS digital servo  
Red LED : AS analog servo  
綠燈：DS 數位伺服器  
紅燈：AS 類比伺服器



digital / analog mode  
數位 / 類比模式



Using an analog servo in DS mode will cause damages to the servo.  
在 DS 模式下連接 "AS 類比伺服器" 將導致伺服器燒毀。

Select by moving the rudder stick left and right  
左右撥動方向舵選擇



## 3. RUDDER SERVO DIRECTION CHECK AND LINK ADJUSTMENT

檢查尾舵伺服器正逆轉方向與調整連桿

Move the transmitter rudder stick left/right, and check for the correct direction of the rudder servo. If needed, servo reverse is done from the transmitter's REV (reverse) function.

For tail pitch adjustment, center the rudder servo by either setting the GP900 to normal rate mode (non-heading lock), or press and hold the SET button for 2 seconds. With the rudder servo centered and servo horn at 90 degrees, adjust the linkage length until tail pitch slider is centered on the tail output shaft as shown in diagram.

左右撥動尾舵搖桿，確認尾舵伺服器移動的方向是否正確，若不正确請更改遙控器上的尾舵伺服器正逆轉方向。

將 GP900 切換成非鎖定模式或持按 "SET" 鍵 2 秒，使尾舵伺服器保持在中立點的位置上，調整伺服舵片，盡可能使尾舵連桿與伺服擺臂呈 90 度，接著調整連桿長度使尾 Pitch 控制組置中。

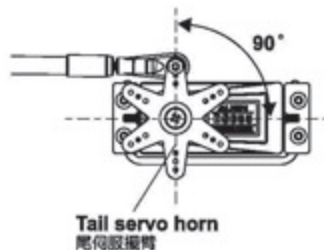

Tail servo horn  
尾伺服擺臂

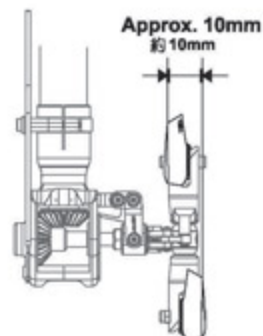

Approx. 10mm  
約 10mm

#### 4. GYRO NOR/REV SETTING NOR / REV 陀螺儀正反向開關設定

Lift up the helicopter by hand, and turn it to the left (yaw). Check if the rudder servo is applying correct compensation to the right. If reversed, set the NOR/REV setting as follow.

Setup method : Press and hold the SET button for 2 seconds to enter the setup mode, then press the SET button to select NOR/REV setup mode, as indicated by the lighting of NOR/REV LED. Using the transmitter's rudder stick, select either NOR (STATUS LED is green), or REV (STATUS LED is red).

提起直昇機，將機頭往左擺動，若尾舵伺服器的擺動方向與遙控器的方向舵搖桿打右舵同方向時，表示陀螺儀的動作方向設定正確，若不正确時請更改正反向設定。

設定方式：持按"SET"鍵2秒進入功能設定模式，選擇NOR / REV選項，以方向舵選擇NOR (STATUS為綠燈) 或REV (STATUS為紅燈)。



Select by moving the rudder stick left and right  
左右撥動方向舵選擇



#### 5. LIMIT RUDDER SERVO ENDPOINT SETTING LIMIT 尾舵伺服器行程量調整

Press and hold the SET button for 2 seconds to enter the setup mode, then press the SET button repeatedly to select LIMIT setup mode, as indicated by the lighting of LIMIT LED. Push the transmitter rudder stick left until tail pitch slider reaches the end, then center the rudder stick and wait 2 seconds for the STATUS LED to flash red. Then push the rudder stick right until tail pitch slider reaches the end, then center the rudder stick and wait 2 seconds for the STATUS LED to flash red. This completes the left and right endpoint limit adjustment of servo travel. Insufficient servo travel will degrade helicopter performance, while excessive travel will cause binding and damage rudder servo.

持按"SET"鍵2秒進入功能設定模式，此時尾舵伺服器會保持在中立點的位置上，選擇LIMIT選項，接著將方向舵搖桿慢慢的往左移動，使尾控制組達到該側的大行程限度後，將搖桿回歸中立點不動，待2秒後"STATUS"指示燈會亮紅燈閃爍，表示左側行程量已記憶；接著將尾舵搖桿向右移動至控制組最大行程限度後，再將搖桿回歸中立點不動，待2秒後"STATUS"指示燈亮紅燈閃爍，即完成左右行程量設定，行程量不足時會影響陀螺儀與直昇機的性能，行程量過大易造成伺服器損壞。

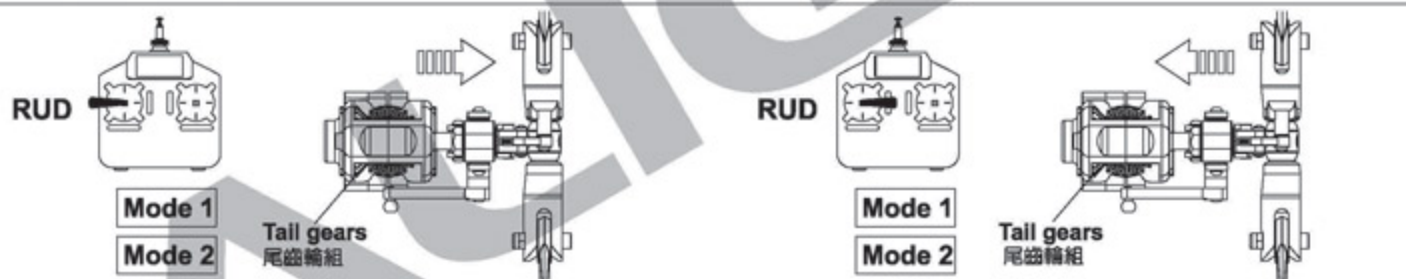

Push the transmitter rudder stick left until tail pitch slider reaches the end, then center the rudder stick and wait 2 seconds for the STATUS LED to flash red. This completes the rudder endpoint limit adjustment for the left side.

將方向舵慢慢往左撥動，使控制組達到左舵最大行程限度後，將搖桿回歸中立點不動，待2秒後"STATUS"紅燈閃爍表示左舵行程記憶量完成。

Push the rudder stick right until tail pitch slider reaches the end, then center the rudder stick and wait 2 seconds for the STATUS LED to flash red. This completes the rudder endpoint limit adjustment for the right side.

將方向舵慢慢往右撥動，使控制組達到右舵最大行程限度後，將搖桿回歸中立點不動，待2秒後"STATUS"指示燈表示右舵行程記憶量完成。

Flashing red LED indicates settings have been registered  
紅燈閃爍時表示記憶完成

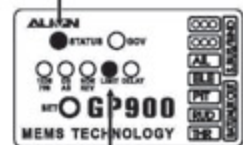

Endpoint limit settings  
行程量設定



To avoid degraded gyro performance as result of insufficient travel range, rudder travel limit setting should not be set to below 50%.

尾舵行程量設定不可低於50%，避免行程不足影響陀螺儀性能。

#### 6. HELICOPTER SIZE AND DELAY SETTINGS 直昇機模式與DELAY控制延遲量調整

This setting includes two functions :

(1) For small helicopters such as T-REX 250/450, set this setting to small helicopter (STATUS LED red). For larger helicopters such as T-REX 500/550/600/700 set this setting to large helicopter (STATUS LED green).

此設定結合兩項功能：

(1) GP900支援小型/迷你室內電直，請依您直昇機的類型選擇適合的模式，如：T-REX250/450請選擇小型/迷你型模式（設定時"STATUS"指示燈為紅色）；T-REX500/550/600/700請選中大型直昇機模式（設定時"STATUS"指示燈為綠色）。



Green LED: suitable for larger helicopters such as T-REX500/550/600/700

Red LED: suitable for smaller helicopters such as T-REX 250/450

綠燈：適用T-REX500/550/600/700大型直昇機

紅燈：適用T-REX250/450小型直昇機

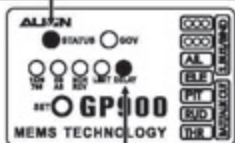

### Helicopter size selection and servo delay settings

大小直昇機模式與延遲量設定

- (2) The DELAY function is utilized when slower rudder servo causes tail hunting (wagging). This can be observed after a hovering pirouette comes to a stop. If tail hunting occurs, gradually increase DELAY value to eliminate it. For best performance, DELAY value should be kept as low as possible without tail hunting.

Setup method : Press and hold the SET button for 2 seconds to enter the setup mode, then press the SET button to select DELAY setup mode, as indicated by the lighting of DELAY LED. The choice of small or large helicopter is done by moving the transmitter rudder stick left or right while observing the color of the STATUS LED. For small helicopters STATUS LED will be red, and large helicopter will be green. The amount of servo delay is set by how far you push the rudder stick, followed by pushing the SET button.

- (2) 使用速度較慢的尾舵伺服器容易產生追蹤現象，當直昇機停懸時，打方向舵使直昇機快速自轉，當方向舵回到中立點使直昇機停止自轉時，此時若發生追蹤現象，請增加控制延遲的設定量，一般而言在不產生追蹤現象的原則下控制延遲的設定量愈小愈好，否則尾舵的動作會變得遲緩。

設定方式：持按“SET”鍵2秒進入功能設定模式，選擇至DELAY選項，以方向舵搖桿選擇小型/迷你型電直，

如：T-REX 250/450 (STATUS為紅燈)，或中大型直昇機如T-REX500/550/600/700 (STATUS為綠燈)，若要同時設定DELAY控制量時，則利用方向舵搖桿的位置來設定，搖桿由中立點推至“DELAY”燈開始閃爍時為0%，推至最大行程時控制量為100%，將搖桿推至所需的延遲量時保持不動，並按下“SET”鍵確認，即可同時設定直昇機模式與延遲量。

Select by moving the rudder stick left and right  
左右撥動方向舵選擇



Green LED for T-REX700  
T-REX700設定為綠燈

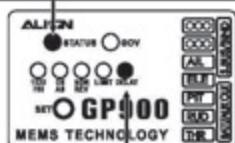

0% when DELAY LED  
begins flashing  
DELAY燈開始閃爍時為0%

Green LED for T-REX700  
T-REX700 設定為綠燈



Gradually move the transmitter rudder stick until DELAY LED  
begins to flash, the delay value is 0% at this point.  
輕推方向舵搖桿至“DELAY”燈開始閃爍時，延遲量為0%



Continue to move the rudder stick until desired delay value  
is needed, then press the SET button to register the setting.  
Maximum is 100% delay, with rudder stick pushed to the end.  
方向舵推至最大行程時，延遲量為100%，將搖桿推至所需的延遲量，按下“SET”鍵確認

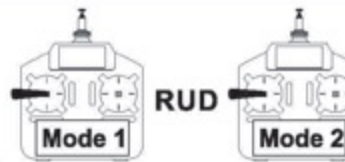

## 7. ANTI TORQUE COMPENSATION DIRECTION SETTING

反扭力補償正反向設定

To achieve consistent gyro gain on left and right, GP900 has built in anti-torque compensation function. User need to confirm if GP900 is mounted right side up or upside down.

Right side up : Installed with GP900 label facing up, anti-torque compensation set to positive (green STATUS LED).

Upside down : Installed with GP900 label facing down, anti-torque compensation set to negative (red STATUS LED).

為使陀螺儀左右感度一致，GP900內置反扭力補償功能，使用者需確認GP900為正裝或反裝。

正裝：安裝時GP900面板朝上，反扭力補償設為正向 (STATUS綠燈)。

反裝：安裝時GP900面板朝下，反扭力補償設為反向 (STATUS紅燈)。

Setup method: Press and hold the SET button for 2 seconds to enter setup mode, select until anti-torque compensation section , as indicated by lighting of all 5 setup mode LEDs. Using the rudder stick to select either positive anti-torque compensation (green STATUS LED) for right side up mounting, or negative anti-torque compensation (red STATUS LED) for upside down installation.

設定方式：持按“SET”鍵2秒進入功能設定模式，選擇至反扭力補償設定項，此時5顆功能設定指示燈全亮，接著以方向舵搖桿選擇，當GP900正裝時，須設定為正向 (STATUS綠燈)；當GP900反裝時，須設定為反向 (STATUS紅燈)。

Green : Right side up mounting

Red : Upside down mounting

綠燈：GP900正裝，反扭力補償正向

紅燈：GP900反裝，反扭力補償反向



Anti Torque Compensation  
direction setting  
反扭力補償正反向設定

Select by moving the rudder stick left and right  
左右撥動方向舵選擇

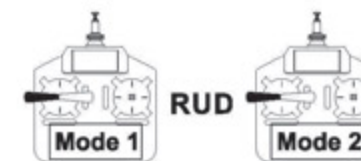

## 8. SENSITIVITY ADJUSTMENT

### 感度調整

For radio with built in gyro gain settings, gain can be adjusted directly. For example, 50%-100% setting on the radio translates to 0% - 100% gain in the heading lock mode; 50%-0% setting on the radio translates to 0%-100% gain in the normal (non-heading) lock mode.

Actual gain value differs amongst servos and helicopters. The goal is to find the maximum gain without tail hunting. This can only be done through actual flight tests.

The recommended starting point for transmitter's gyro gain setting should be 70~80% for hovering, 60~70% for idle-up. Value should be tuned under actual flight conditions by increasing to the maximum gain without tail hunting.

一般具有陀螺儀感度設定功能的遙控器，可直接進入GYRO功能選項進行感度值的設定，設定值50%則陀螺儀的感度為0，設定值50%~100%，則陀螺儀感度值為鎖定狀態的0~100%；設定值50%~0%，則陀螺儀感度值為非鎖定狀態的0~100%。

感度值的大小會隨著伺服器與直昇機的不同而有所差異，一般而言，在不產生追蹤現象（直昇機尾部出現左右搖擺的情況）的前提下感度值愈高愈好，所以只能透過實際飛行的狀況來進行調整。

進入遙控器感度設定的選項，剛開始時應建議先設定在70~80%左右，Idle up飛行時設定在60~70%左右，之後再依實際飛行的狀態再行修正，如果沒有追蹤現象發生時可再調整高感度，若發生追蹤現象時，則調低感度。



For radios (IE Futaba) using 0-100% as heading lock gain scales, the recommended gain setting is 30% to 35%. For radio that uses the 50 -100% scale (such as JR and Hitec), the recommended gain setting is 70% to 75%. 鎖定感度值為0~100%的遙控器，如Futaba，建議設定在30~35%左右；鎖定感度值為50~100%的遙控器，如JR、HITEC，建議感度值設定在70~75%左右。

## GP900 GYRO SPECIFICATIONS GP900 陀螺儀產品規格

- Operating Voltage: DC 3.5~8.4V
- Operating Humidity: 0%~95%
- 適用電壓: DC 3.5V~8.4V
- 操作濕度: 0%~95%
- Current Consumption: <80mA @ 4.8V
- Size: 36.5x25.2x15.6mm
- 消耗電流: <80mA @ 4.8V
- 尺寸: 36.5x25.2x15.6mm
- Angular Detection Speed: ± 300 degrees/sec
- Weight: 11g
- 偵測角速度 ± 300度/sec
- 重量: 11g
- Operating Temperature: -20°C ~65°C
- RoHS compliant
- 操作溫度: -20°C ~65°C
- 符合 RoHS 限用規章

## 17.RCM-BL750MX 450KV POWER COLLOCATION REFERENCE 原裝動力數據參考表 ALIGN

BATTERY 電池: ALIGN Li-Poly 44.4V 5200mAh

ESC 無刷調速器: CASTLE ICE2 HV 120 GOVERNOR MODE SET 定速模式設定

Motor Pinion Gear 馬達齒輪	Main Rotor Blade 主旋翼規格	Pitch 螺距	Current(A) approx. 電流(A)大約值	Throttle Curve 油門曲線	Desired Head Speed 主旋翼轉速設定值	
12T	700 F3C Carbon Fiber Blades 700 F3C 碳纖維主旋翼	Hover 停懸	+5°	14	Governor mode: up to 50% 定速模式 50% 以下	1450
		Idle UP	0°	16	Governor mode: 50%~99% 定速模式 50%~99%	1900
			± 12°	54		
			0°	18	Governor mode: above 99% 定速模式 99% 以上	2000
± 12°	57					

NOTE: Please use a pitch gauge to adjust the pitch value. Incorrect excess pitch setting will result poor helicopter performance and reduce ESC's life and battery's life.

註: 請務必使用螺距規來量測調整螺距，不正確的過大螺距設定不但無法發揮直昇機的特性，反會影響到無刷調速器與電池的壽命。

## RCM-BL750MX MOTOR RCM-BL750MX 無刷馬達

### SPECIFICATION 尺寸規格



KV	KV 值	450KV(RPM/V)	Input voltage 輸入電壓	12S
Stator Arms	矽鋼片槽數	12	Magnet Poles 磁鐵極數	10
Max continuous current	最大持續電流	100A	Max instantaneous current 最大瞬間電流	165A(5sec)
Max continuous power	最大持續功率	4400W	Max instantaneous power 最大瞬間功率	7260W(5sec)
Dimension	尺寸	Shaft 軸 φ 6x52x97.6mm	Weight 重量	Approx. 452g

### ILLUSTRATION 接線示意圖

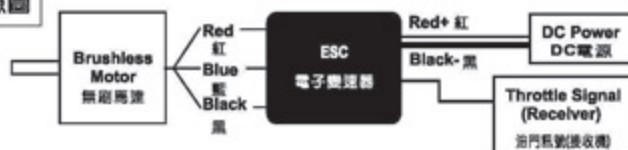

The motor rotates in different direction with different brand ESCs. If the wrong rotating direction happens, please switch any two cables to make the motor rotates in right direction.

由於各品牌電子變速器的馬達啟動轉向不盡相同，若發生轉向錯誤時，請將馬達與電子變速器的接線任兩條對調即可。

## PLEASE PRACTICE SIMULATION FLIGHT BEFORE REAL FLYING 飛行前請先熟練模擬飛行

Do a simulation flight until you familiarize your fingers with the movements of the rudders, and keep practicing until the fingers move naturally.

1. Place the helicopter in a clear open field ( Make sure the power OFF ) and the tail of helicopter point to yourself.
2. Practice to operate the throttle stick (as below illustration) and repeat practicing "Throttle high/low", "Aileron left/right", "Rudder left/right", and "Elevator up/down".
3. The simulation flight practice is very important, please keep practicing until the fingers move naturally when you hear operation orders being call out.
4. Another safe and effective practice method is to use the transmitter flying on the computer through simulator software sold on the market.

在還沒瞭解直昇機各動作的操控方式前，嚴禁通電飛行，請先進行模擬飛行的練習，並不斷的重複，直到手指可熟練的控制各個動作及方向。

1. 將直昇機放在空曠的地方 ( 確認電源為關閉 )，並將直昇機的機尾對準自己。
2. 練習操作遙控器的各搖桿 ( 各動作的操作方式如下圖 )，並反覆練習油門高/低、副翼左/右、升降舵前/後及方向舵左/右操作方式。
3. 模擬飛行的練習相當重要，請重複練習直到不需思索，手指能自然隨著喊出的指令移動控制。
4. 另外一種最有效、最安全的練習方式，就是透過市面販售的模擬軟體，以遙控器在電腦上模擬飛行，熟悉各種方向的操控。



Mode 1	Mode 2	Illustration 圖示
<p>Aileron 副翼</p>		
<p>Elevator 升降/前後</p>		
<p>Throttle 油門</p>		
<p>Rudder 方向</p>		

## FLIGHT ADJUSTMENT AND NOTICE 飛行調整與注意



注意

- Check if the screws are firmly tightened.
- Check if the transmitter and receivers are fully charged.
- 再次確認→螺絲是否鎖固?
- 發射器和接收器電池是否足夠。



注意

If there are other radio control aircraft at the field, make sure to check their frequencies and tell them what frequency you are using. Frequency interference can cause your model, or other models to crash and increase the risk of danger.

假使飛行場有其他遙控飛機，請確認他們的頻率，並告知他們你正在使用的頻率，相同的頻率會造成干擾導致失控和大大地增加風險。

- ★ When arriving at the flying field.
- ★ 當抵達飛行場



## STARTING AND STOPPING THE MOTOR 啟動和停止馬達



注意

First check to make sure no one else is operating on the same frequency. Then place the throttle stick at lowest position and turn on the transmitter.

首先確認附近沒有其他相同頻率的使用，然後打開發射器將油門搖桿推低點。



注意

Check if the throttle stick is set at the lowest position.

確認油門搖桿是在最低的位置。

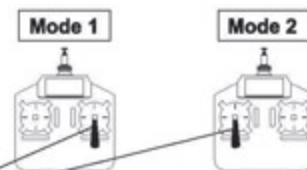

★ Check the movement.

★ 動作確認



ON! Step1

First turn on the transmitter.  
先開啟發射器

- ⊙ Are the rudders moving according to the controls?
- ⊙ Follow the transmitter's instruction manual to do a range test.
- ⊙ 方向舵是否隨著控制方向移動?
- ⊙ 根據發射器說明書進行距離測試。



ON! Step2

Connect to the helicopter power  
接上直昇機電源



OFF! Step3

Reverse the above orders to turn off.  
關閉電源時請依上述操作動作反執行。

MAIN ROTOR ADJUSTMENTS 主旋翼雙槳平衡調整

1. Before adjusting, apply a red piece of tape on one blade, or paint a red stripe with a marker or paint to identify on blade.
2. Raise the throttle stick slowly and stop just before the helicopter lifts-off ground. Look at the spinning blades from the side of the helicopter.
3. Look at the path of the rotor carefully. If the two blades rotate in the same path, it does not need to adjustment. If one blade is higher or lower than the other blade, adjust the tracking immediately.

1. 調整前先在其中一支主旋翼的翼端，貼上有顏色的貼紙或畫上顏色記號，方便雙槳調整辨識。
2. 慢慢的推起油門搖桿到高點並且停止，在飛機離開地面前，從飛機側邊觀察主旋翼轉動。
3. 仔細觀察旋翼軌跡(假如兩支旋翼移動都是相同軌跡，則不需要調整;可是如果一支旋翼較高或較低產生“雙槳”的情形時，則必須立刻調整軌跡)。

- A. When rotating, the blade with higher path means the pitch too big.  
linkage rod (C) for slight pitch trim.
- B. When rotating, the blade with lower path means the pitch too small.  
linkage rod (C) for slight pitch trim.

- A. 旋翼轉動時較高軌跡的主旋翼表示螺距(PITCH)過大，請調短連桿(C)修正。
- B. 旋翼轉動時較低軌跡的主旋翼表示螺距(PITCH)過小，請調長連桿(C)修正。



Tracking adjustment is very dangerous, so please keep away from the helicopter at a distance of at least 10m.  
調整軌跡非常危險，請於距離飛機最少10公尺的距離。

Incorrect tracking may cause vibrations. Please repeat adjusting the tracking to make sure the rotor is correctly aligned. After tracking adjustment, please check the pitch angle is approx. 5° when hovering.  
不正確的旋翼軌跡會導致震動，請不斷重複調整軌跡，使旋翼軌跡精準正確。  
在調整軌跡後，確認一下Pitch角度在停旋時應為大約5°

FLIGHT ADJUSTMENT AND NOTICE FOR BEGINNERS 初學飛行調整與注意

- ⊙ During the operation of the helicopter, please stand approximately 10m diagonally behind the helicopter.
- ⊙ 飛行時，請站在直昇機後方最少10公尺。



- ⊙ Make sure that no one or obstructions in the vicinity.
- ⊙ For flying safety, please carefully check if every movement and directions are correct when hovering.
- ⊙ 確認鄰近地區沒有人和障礙物。
- ⊙ 為了飛行安全，您必須先確認停懸時各項操控制作是否正確。



Do not attempt until you have some experiences with the operation of helicopter.  
嚴禁無熟練操控飛行經驗者操控飛行。

STEP 1 THROTTLE CONTROL PRACTICE 油門控制練習

- ⊙ When the helicopter begins to lift-off the ground, slowly reduce the throttle to bring the helicopter back down. Keep practicing this action until you control the throttle smoothly.
- ⊙ 當直昇機開始離地時，慢慢降低油門將飛機降下。  
持續練習飛機從地面上升和下降直到你覺得油門控制很順。

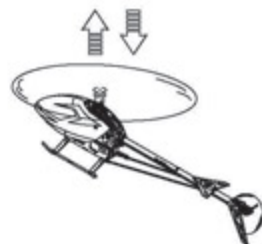
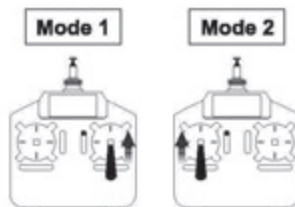

STEP 2 AILERON AND ELEVATOR CONTROL PRACTICE 副翼和升降控制練習

1. Raise the throttle stick slowly.
  2. Move the helicopter in any direction back, forward, left and right, slowly move the aileron and elevator sticks in the opposite direction to fly back to its original position.
1. 慢慢升起油門搖桿。
  2. 使直昇機依指示:移動向後/向前/向左/向右，慢慢的反向移動副翼和升降搖桿並將直昇機開回到原來位置。

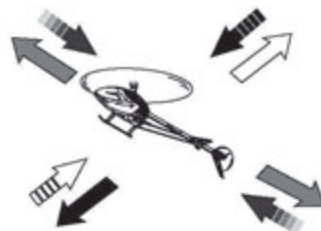
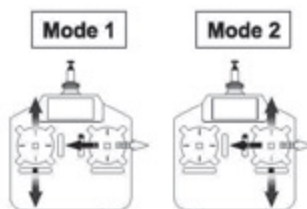

- ⊙ If the nose of the helicopter moves, please lower the throttle stick and land the helicopter. Then move your position diagonally behind the helicopter 10m and continue practicing.
- ⊙ If the helicopter flies too far away from you, please land the helicopter and move your position behind 10m and continue practicing.
- ⊙ 當直昇機機頭偏移時，請降低油門並且降落，然後移動自己的位置到直昇機的正後方10公尺再繼續練習。
- ⊙ 假如直昇機飛離你太遠，請先降落直昇機，並到直昇機後10公尺再繼續練習。

### STEP 3 RUDDER CONTROL PRACTICING 方向舵操作練習

1. Slowly raise the throttle stick.
2. Move the nose of the helicopter to right or left, and then slowly move the rudder stick in the opposite direction to fly back to its original position.

1. 慢慢升起油門搖桿。
2. 將直昇機機頭移動左或右，然後慢慢反向移動方向舵搖桿並將直昇機飛回原本位置。



### STEP 4

After you are familiar with all actions from Step1 to 3, draw a circle on the ground and practice within the circle to increase your accuracy.

當你覺得 step1~3 動作熟悉了，在地上畫個圈並在這個圈內的範圍內練習飛行，以增加你操控的準確度。

- ◎ You can draw a smaller circle when you get more familiar with the actions.
- ◎ 當你更加習慣操作動作，你可以畫更小的圈。



### STEP 5 DIRECTION CHANGE AND HOVERING PRACTICE 改變直昇機方向和練習停旋

After you are familiar with Step1 to 4, stand at side of the helicopter and continue practicing Step1 to 4. Then repeat the Step1 to 4 by standing in front of the helicopter.

當你覺得 step1~4 動作熟悉了，站在面對直昇機側邊並繼續練習 step1~4。之後，站在直昇機機頭前方重複步驟練習。

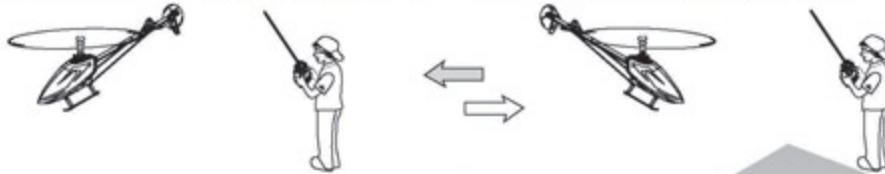

### ADJUSTMENT OF EACH TRIM 飛行動作微調

Slowly raise the throttle stick and just as the helicopter lift-off the ground, you can use the trim to correct the action if the helicopter leans in a different direction.

慢慢升起油門搖桿，當直昇機剛剛離開地面時，若直昇機傾向不同方向，可使用微調修正動作。

1. Adjustment of elevator trim 調整升降舵微調  
Just before the helicopter lift-off, the nose lean forward/backward...

When leans forward, adjust the trim down.  
When leans backward, adjust the trim up.

在直昇機正要起飛時，機頭朝前/後方向偏移...  
向前偏移時，微調向下調整。  
向後偏移時，微調向上調整。

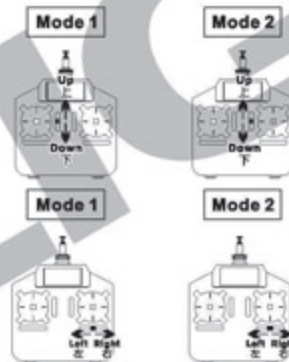

2. Adjustment of Aileron trim 調整副翼微調  
Just before the helicopter lift-off, the body lean left/right...

When leans right, adjust the trim to left side.  
When leans left, adjust the trim to right side.

在直昇機正要起飛時，機身朝左/右方向偏移...  
向右偏移時，微調向左調整。  
向左偏移時，微調向右調整。

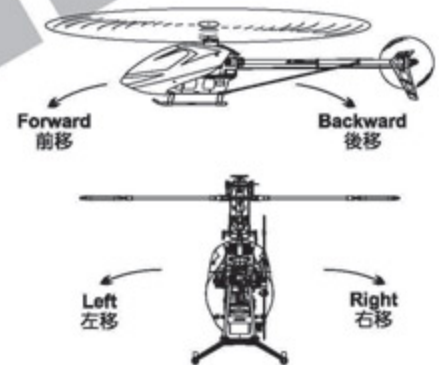

### TROUBLE SHOOTING DURING FLIGHT 如何排除飛行中的狀況

	Situation 狀況	Cause 原因	Way to deal 對策
Blade Tracking 雙槳平衡	Out of tracking 雙槳	Adjustment of pitch rod has not been done. PITCH 連桿長度調整不平均	Adjust the length of linkage rod(C) 調整連桿(C)長度
During Hovering 停懸	Low rotation of the rotor 主旋翼轉速偏低	★ Pitch of main blade is high. ★ 主旋翼的 PITCH 偏高 ★ Throttle curve is too low during hovering. ★ 停懸點油門曲線過低	★ Lower the pitch about 4~5° during hovering(The rotation should be about 1450~1500rpm during hovering). ★ 調低 Pitch 停懸 Pitch 約 4~5° (停懸時主旋翼轉速為約 1450~1500RPM) ★ Heighten the throttle curve during hovering. ★ 調高停懸點油門曲線
	High rotation of the rotor 主旋翼轉速偏高	★ Pitch of main blade is low. ★ 主旋翼的 PITCH 偏低 ★ Throttle curve is too high during hovering. ★ 停懸點油門曲線過高	★ Adjust the pitch rod (C) (The rotation should be about 1450~1500rpm during hovering). ★ 調整連桿 (C) (停懸時主旋翼轉速為約 1450~1500RPM) ★ Lower the throttle curve during hovering. ★ 調低停懸點油門曲線
Sensitivity of the gyro 陀螺儀敏感度	The tail leans to one side during hovering, or when trim the rudder and return to the neutral, the tail lags and cannot stay in a control position. 停懸時尾翼向某一邊偏移，或撥動方向舵並回復到中立點時，尾翼產生延遲，無法停頓在所控制位置上。	★ Failure setting of tail neutral point. ★ 尾中立點設定不當 ★ The sensitivity of the gyro is low. ★ 陀螺儀敏感度偏低	★ Reset tail neutral point. ★ 重設尾中立點 ★ Increase the sensitivity. ★ 增加敏感度
	The tail wags left and right during flight at hovering or full speed. 停懸或全油門時尾翼左右來回快速搖擺。	The sensitivity of the gyro is high. 陀螺儀敏感度偏高	Decrease the sensitivity. 降低敏感度

※ If the problem is still there even after tried above, stop flying and contact with your seller.  
※ 在做完以上調整後，仍然無法改善情況時，應立即停止飛行並連絡您的經銷商。

# ALIGN

## Specifications & Equipment/規格配備:

Length/機身長:1343mm

Height/機身高:424mm

Main Blade Length/主旋翼長:700mm

Main Rotor Diameter/主旋翼直徑:1582mm

Tail Rotor Diameter/尾旋翼直徑:281mm

Motor Drive Gear/馬達齒輪:12T

Main Drive Gear/主齒輪:112T

Autorotation Tail Drive Gear/尾驅動主齒:104T

Drive Gear Ratio/齒輪傳動比: 9.33:1:4.33

Weight(With Motor)/空機重(含馬達): 3230g

Flying Weight/全配重:Approx. 5200g

