

Super Combo T-REX 600E PRO INSTRUCTION MANUAL 使用說明書

Model:KX016016T



Contents	
1	INTRODUCTION 前言
1~2	SAFETY NOTES 安全注意事項
3	EQUIPMENT REQUIRED FOR ASSEMBLY 自備設備
3	PACKAGE ILLUSTRATION 包裝說明
4	SAFETY CHECK BEFORE FLYING 飛行前安全檢查
5~18	ASSEMBLY SECTION 組裝說明
19	BATTERY INSTALLATION ILLUSTRATION 電池安裝示意圖
19	EQUIPMENT INSTALLATION 各項設備配置圖
20	INSTALLATION FOR ESC AND BEC 無刷調速器與BEC安裝
20	CANOPY ASSEMBLY 機頭罩安裝
21	ELECTRIC EQUIPMENT ILLUSTRATION 電子設備建議配置圖示
22	SERVO SETTING AND ADJUSTMENT 伺服器設定調整
22	ADJUSTMENTS FOR GYRO AND TAIL NEUTRAL SETTING 陀螺儀與尾翼中立點調整
23	PITCH AND THROTTLE SETTING 主旋翼螺距與油門設定
24	RCM-BL600M 1220KV POWER COLLOCATION REFERENCE 原裝動力線或參考表
25	6A EXTERNAL BEC INSTRUCTION MANUAL 6A外接式BEC使用說明
25~28	GP780 HEAD LOCK GYRO SET USER MANUAL GP780固定式陀螺儀組使用說明
28~30	FLIGHT ADJUSTMENT AND SETTING 飛行動作調整與設定

Thank you for buying ALIGN products. The **T-REX 600E PRO** is the latest technology in Rotary RC models. Please read this manual carefully before assembling and flying the New **T-REX 600E PRO** helicopter. We recommend that you keep this manual for future reference regarding tuning and maintenance.

承蒙閣下選用亞拓遙控世界系列產品，謹表謝意。進入遙控世界之前必須告訴您許多相關的知識與注意事項，以確保您能夠在學習的過程中較得心應手。在開始操作之前，請務必詳閱本說明書，相信一定能夠給您帶來相當大的幫助，也請您妥善保管這本說明書，以作為日後參考。

Thank you for buying ALIGN Products. The T-REX 600 E PRO Helicopter is designed as an easy to use, full featured Helicopter R/C model capable of all forms of rotary flight. Please read the manual carefully before assembling the model, and follow all precautions and recommendations located within the manual. Be sure to retain the manual for future reference, routine maintenance, and tuning.

The T-REX 600 E PRO is a new product developed by ALIGN. It provides flying stability for beginners, full aerobatic capability for advanced fliers, and unsurpassed reliability for customer support.

感謝您選購亞拓產品，為了讓您容易方便的使用 T-REX 600E PRO 直昇機，請您詳細的閱讀完這本說明書之後再進行組裝以及操作這台直昇機，同時請您妥善的保存這本說明書，作為日後進行調整以及維修的參考。

T-REX 600E PRO 是由亞拓自行研發的新產品，不論你是需求飛行穩定性的初學者或是追求性能的飛行愛好者，T-REX 600E PRO 將是你最佳的選擇。

WARNING LABEL LEGEND 標誌代表涵義

 WARNING 警告	Mishandling due to failure to follow these instructions may result in damage or injury. 因為疏忽這些操作說明，而使用錯誤可能造成財產損失或嚴重傷害。
 CAUTION 注意	Mishandling due to failure to follow these instructions may result in danger. 因為疏忽這些操作說明，而使用錯誤可能造成危險。
 FORBIDDEN 禁止	Do not attempt under any circumstances. 在任何禁止的環境下，請勿嘗試操作。

IMPORTANT NOTES 重要聲明

R/C helicopters, including the T-REX 600 E PRO are not toys. R/C helicopter utilize various high-tech products and technologies to provide superior performance. Improper use of this product can result in serious injury or even death. Please read this manual carefully before using and make sure to be conscious of your own personal safety and the safety of others and your environment when operating all ALIGN products.

Manufacturer and seller assume no liability for the operation or the use of this product. Intended for use only by adults with experience flying remote control helicopters at a legal flying field. After the sale of this product we cannot maintain any control over its operation or usage.

T-REX 600E PRO 遙控直昇機並非玩具，它是結合了許多高科技產品所設計出來的休閒用品，所以商品的使用不當或不熟悉都可能造成嚴重傷害甚至死亡，使用之前請務必詳讀本說明書，勿疏忽並注意自身安全。

注意：任何遙控直昇機的使用，製造商和經銷商是無法對使用者於零件使用的損耗異常或組裝不當所發生之意外負任何責任，本產品是提供給有操作過模型直昇機經驗的成人或有相當技術的人員在旁指導於當地合法遙控飛行場飛行，以確保安全無虞下操作使用，產品售出後本公司將不負責任何操作和使用控制上的任何性能與安全責任。

We recommend that you obtain the assistance of an experienced pilot before attempting to fly our products for the first time. A local expert is the best way to properly assemble, setup, and fly your model for the first time. The Helicopter requires a certain degree of skill to operate, and is a consumer item. Any damage or dissatisfaction as a result of accidents or modifications are not covered by any warranty and cannot be returned for repair or replacement. Please contact our distributors for free technical consultation and parts at discounted rates when you experience problems during operation or maintenance.

模型商品屬於需高操作技術且為消耗性之商品，如經拆裝使用後，會造成不等情況零件損耗，任何使用情況所造成商品不良或不滿意，將無法於保固條件內更換新品或退貨，如遇有使用操作維修問題，本公司全省分公司或代理商將提供技術指導、特價零件供應服務。

2. SAFETY NOTES 安全注意事項



Fly only in safe areas, away from other people. Do not operate R/C aircraft within the vicinity of homes or crowds of people. R/C aircraft are prone to accidents, failures, and crashes due to a variety of reasons including, lack of maintenance, pilot error, and radio interference. Pilots are responsible for their actions and damage or injury occurring during the operation or as a result of R/C aircraft models.

遙控模型飛機、直昇機屬高危險性商品，飛行時務必遠離人群，人為組裝不當或機件損壞、電子控制設備不良，以及操控上的不熟悉，都有可能導致飛行失控損傷等不可預期的意外，請飛行者務必注意飛行安全，並需了解自負疏忽所造成任何意外之責任。

**LOCATE AN APPROPRIATE LOCATION 遠離障礙物及人群**

R/C helicopters fly at high speed, thus posing a certain degree of potential danger. Choose an a legal flying field consisting of flat, smooth ground without obstacles.

Do not fly near buildings, high voltage cables, or trees to ensure the safety of yourself, others and your model.

For the first practice, please choose a legal flying field and can use a training skid to fly for reducing the damage. Do not fly your model in inclement weather, such as rain, wind, snow or darkness.

直昇機飛行時具有一定的速度，相對的也潛在著危險性，場地的選擇也相對的重要，請需遵守當地法規到合法遙控飛行場地飛行。

必須注意周邊有沒有人、高樓、建築物、高壓電線、樹木等等，避免操控的不當造成自己與他人財產的損壞。初次練習時，務必選擇在空曠合法專屬飛行場地並適當搭配練習架練習飛行，這對飛行失誤所造成的損傷將會大幅的降低。請勿在下雨、打雷等惡劣天氣下操作，以確保本身及機體的安全。

**PREVENT MOISTURE 遠離潮濕環境**

R/C models are composed of many precision electrical components.

It is critical to keep the model and associated equipment away from moisture and other contaminants. The introduction or exposure to water or moisture in any form can cause the model to malfunction resulting in loss of use, or a crash. Do not operate or expose to rain or moisture.

直昇機內部也是由許多精密的電子零件組成，所以必須絕對的防止潮濕或水氣，避免在浴室或雨天時使用，防止水氣進入機身內部而導致機件及電子零件故障而引發不可預期的意外！

**PROPER OPERATION 勿不當使用本產品**

Please use the replacement of parts on the manual to ensure the safety of instructors. This product is for R/C model, so do not use for other purpose.

請勿自行改造加工，任何的升級改裝或維修，請使用亞拓產品目錄中的零件，以確保結構的安全。請確認於產品限內操作，請勿過載使用，並勿用於安全、法令外其它非法用途。

**OBTAIN THE ASSISTANCE OF AN EXPERIENCED PILOT 避免獨自操控**

Before turning on your model and transmitter, check to make sure no one else is operating on the same frequency. Frequency interference can cause your model, or other models to crash.

The guidance provided by an experienced pilot will be invaluable for the assembly, tuning, trimming, and actual first flight.

(Recommend you to practice with computer-based flight simulator.)

至飛行場飛行前，需確認是否有相同頻率的同好正進行飛行，因為開啓相同頻率的發射機將導致自己與他人立即干擾等意外危險。

遙控飛機操控技巧在學習初期有著一定的難度，要盡量避免獨自操作飛行，需有經驗的人士在旁指導，才可以操控飛行。(對練電腦模擬器及老手指導是入門必要的選擇)

**SAFE OPERATION 安全操作**

Operate this unit within your ability. Do not fly under tired condition and improper operation may cause in danger.

請於自己能力內及需要一定技術範圍內操作這台直昇機，過於疲勞、精神不佳或不當操作，意外發生風險將可能提高。

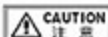
**ALWAYS BE AWARE OF THE ROTATING BLADES 遠離運轉中零件**

During the operation of the helicopter, the main rotor and tail rotor will be spinning at a high rate of speed. The blades are capable of inflicting serious bodily injury and damage to the environment. Be conscious of your actions, and careful to keep your face, eyes, hands, and loose clothing away from the blades. Always fly the model a safe distance from yourself and others, as well as surrounding objects. Never take your eyes off the model or leave it unattended while it is turned on. Immediately turn off the model and transmitter when you have landed the model.

當直昇機主旋翼與尾旋翼運轉時，切勿觸摸並遠離任何物件，以避免造成危險及損壞。

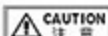
**KEEP AWAY FROM HEAT 遠離熱源**

R/C models are made up various forms of plastic. Plastic is very susceptible to damage or deformation due to extreme heat and cold climate. Make sure not to store the model near any source of heat such as an oven, or heater. It is best to store the model indoors, in a climate-controlled, room temperature environment.







遙控飛機多半是以 PA 纖維或聚乙烯、電子商品為主要材質，因此要盡量遠離熱源、日曬，以避免因高溫而變形甚至熔毀損壞的可能。











3.EQUIPMENT REQUIRED FOR ASSEMBLY 自備設備

ALIGN

RADIO TRANSMITTER AND ELECTRONIC EQUIPMENT REQUIRED FOR ASSEMBLY 自備遙控及電子設備

 <p>Transmitter (7-channel or more, helicopter system) 發射機(七動以上直升機模式遙控器)</p>	 <p>Receiver(7-channel or more) 接收機(七動以上)</p>
 <p>22.2V 6S1P 2600~4600mAh Li-Po Battery x 2pcs 22.2V 6S1P 2600~4600mAh Li-Po電池 x 2</p>	 <p>Dial Pitch Gauge x 1pc 旋轉式螺距規 x 1</p>
 <p>Li-Po Battery Charger Li-Po電池充電器</p>	 <p>Receiver battery 7.4V 2S 1900~2300mAh Li Po x 1pc 接收機電池 7.4V 2S 1900~2300mAh Li-Po x 1</p>

ADDITIONAL TOOLS REQUIRED FOR ASSEMBLY 自備工具

 <p>Scissors 剪刀</p>	 <p>Cutter Knife 刀子</p>	 <p>Diagonal Cutting Pliers 斜口鉗</p>	 <p>Needle Nose Pliers 尖嘴鉗</p>
 <p>Oil 潤滑油</p>	 <p>CA 瞬間膠 AB Glue AB膠</p>	 <p>Hexagon Screw Driver 六角螺絲起子 3mm/2.5mm/2mm/1.5mm</p>	 <p>Phillips Screw Driver 十字螺絲起子 φ3.0/φ1.8mm</p>

4.PACKAGE ILLUSTRATION 包裝說明

ALIGN

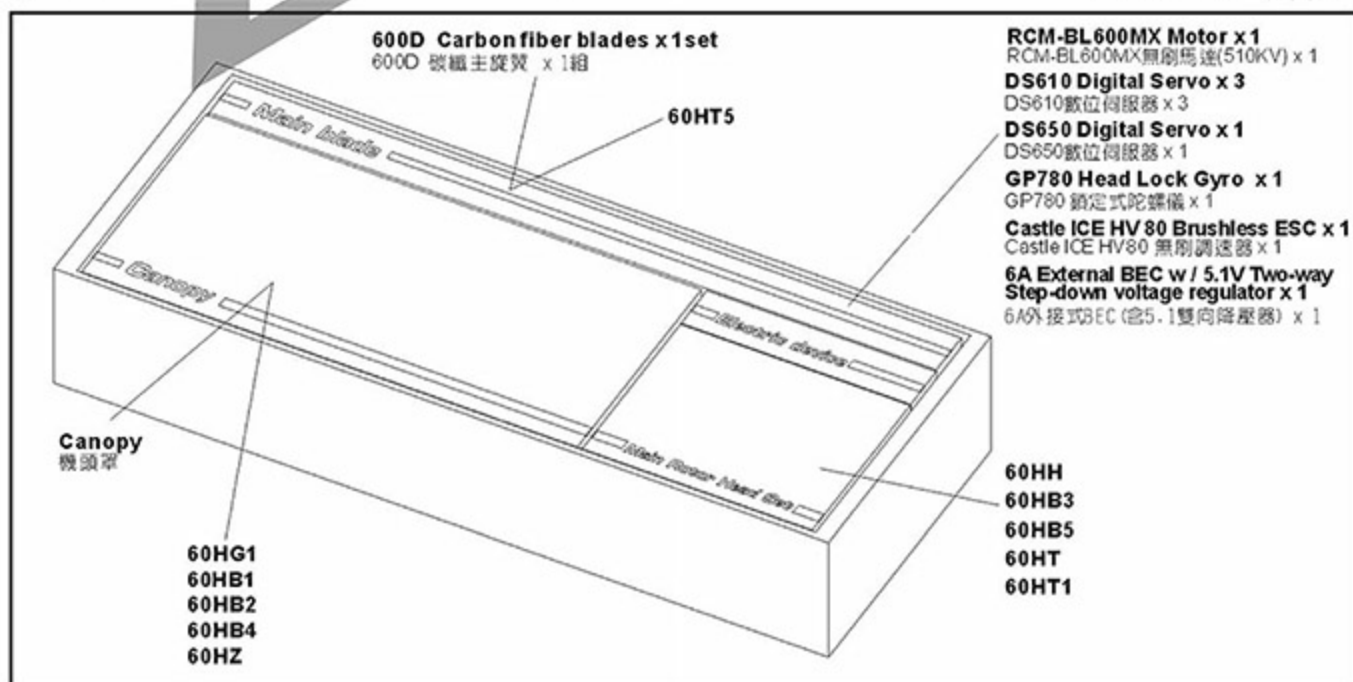

CAREFULLY INSPECT BEFORE REAL FLIGHT 請嚴格執行飛行前之檢查義務

- ☆ Before flying, please check to make sure no one else is operating on the same frequency for the safety.
 - ☆ Before flight, please check if the batteries of transmitter and receiver are enough for the flight.
 - ☆ Before turn on the transmitter, please check if the throttle stick is in the lowest position. IDLE switch is OFF.
 - ☆ When turn off the unit, please follow the power on/off procedure. Power ON- Please turn on the transmitter first, and then turn on receiver. Power OFF- Please turn off the receiver first and then turn off the transmitter. Improper procedure may cause out of control, so please to have this correct habit.
 - ☆ Before operation, check every movement is smooth and directions are correct. Carefully inspect servos for interference and broken gear.
 - ☆ Check for missing or loose screws and nuts. See if there is any cracked and incomplete assembly of parts. Carefully check main rotor blades and rotor holders. Broken and premature failures of parts possibly cause resulting in a dangerous situation.
 - ☆ Check all ball links to avoid excess play and replace as needed. Failure to do so will result in poor flight stability.
 - ☆ Check if the battery and power plug are fastened. Vibration and violent flight may cause the plug loose and result out of control.
- ★ 每次飛行前應先確認所使用的頻率是否會干擾他人，以確保你自身與他人的安全。
- ★ 每次飛行前請確認發射機與接收機電池的電量是在足夠飛行的狀態。
- ★ 開機前請認油門搖桿是否位於最低點，熄火降落開關，定速開關 (IDLE) 是否於關閉位置。
- ★ 開機時必須遵守電源開關機的程序，開機時應先開發射機後，再開接收機電源；關機時應先關閉接收機後，再開發射機電源。不正確的開關程序可能會造成失控的現象，影響自身與他人的安全，請養成正確的習慣。
- ★ 開機請先確認直昇機的各個動作是否順暢，及方向是否正確，並檢查伺服器的動作是否有干涉或崩齒的情形，使用故障的伺服器將導致不可預期的危險。
- ★ 飛行前請認沒有缺少或鬆脫的螺絲與螺帽，確認沒有組裝不完整或損壞的零件，仔細檢查主旋翼是否有損壞，特別是接近主旋翼夾座的部位。損壞或組裝不完整的零件不僅影響飛行，更會造成不可預期的危險。注意：每次飛行前的安全檢查、保養、及更換消耗零件，請確實嚴格執行以確保安全。
- ★ 檢查所有的連桿頭是否有鬆脫的情形，過鬆的連桿頭應先更新，否則將造成直昇機無法操控的危險。
- ★ 確認電池及電源接頭是否固定牢靠，飛行中的震動或激烈的飛行，可能造成電源接頭鬆脫而造成失控的危險。

Standard Equipment 標準配備

 60HC1	 60HH	 60HB1	 60HB2	 60HB3	 60HB4	 CNC Slant Thread Main Drive Gear CNC主齒輪組 60HB5
 60HT	 60HT1	 60HT5	 60HG1	 60HZ	 CNC金屬伺服臂 x 3 DS610 Digital Servo x 3 DS 610數位伺服器 x 3	 GP780鎖定向式陀螺儀組 (GP780+DS650)
 M4x4 Set Screw x 1 M4x4 止鎖螺絲 x 2 Motor pinion gear 13T x 1 馬達副齒輪 13T x 1	 Castle ICE HV 80 無刷電調		 6A外置式BEC(含5.1V雙向電壓調節器)	 RCM-BL600MX無刷馬達 (510KV)	 6000 碳纖維主旋翼	

When you see the marks as below, please use glue or grease to ensure flying safety.

標有以下符號之組裝步驟，請配合上膠或上油，以確保使用之可靠度。

- CA : Apply CA Glue to fix.
AB : Apply AB Glue to fix.
R48 : Apply Anaerobics Retainer to fix.
T43 : Apply Thread Lock to fix.
OIL : Add Grease.

- CA : 使用瞬間膠固定
AB : 使用AB膠固定
R48 : 使用金屬管狀固定缺氧膠固定
T43 : 使用螺絲膠
OIL : 添加潤滑油

When assembling ball links, make sure the "A" character faces outside.

各項型膠裝連桿頭扣接時，A字請朝外。

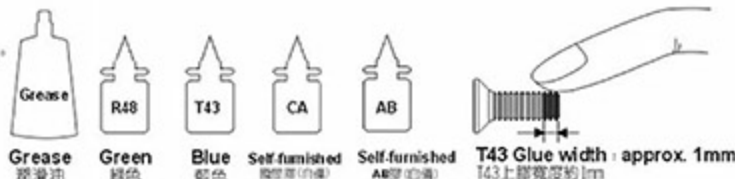

R48 metal tubular adhesive (eg. Bearings). T43 thread lock, apply a small amount on screws or metal parts and wipe surplus off. When disassembling, recommend to heat the metal joint about 15 Seconds. (NOTE : Keep plastic parts away from heat.)

R48 為強力金屬管狀 (如軸承) 接著劑，T43為螺絲膠，膠合螺絲或金屬內外徑請務必少量使用，必要時請用手去餘多餘膠量，欲拆卸時可於金屬接合部位熱約15秒。(注意！塑膠件避免接近熱源)

60HH1

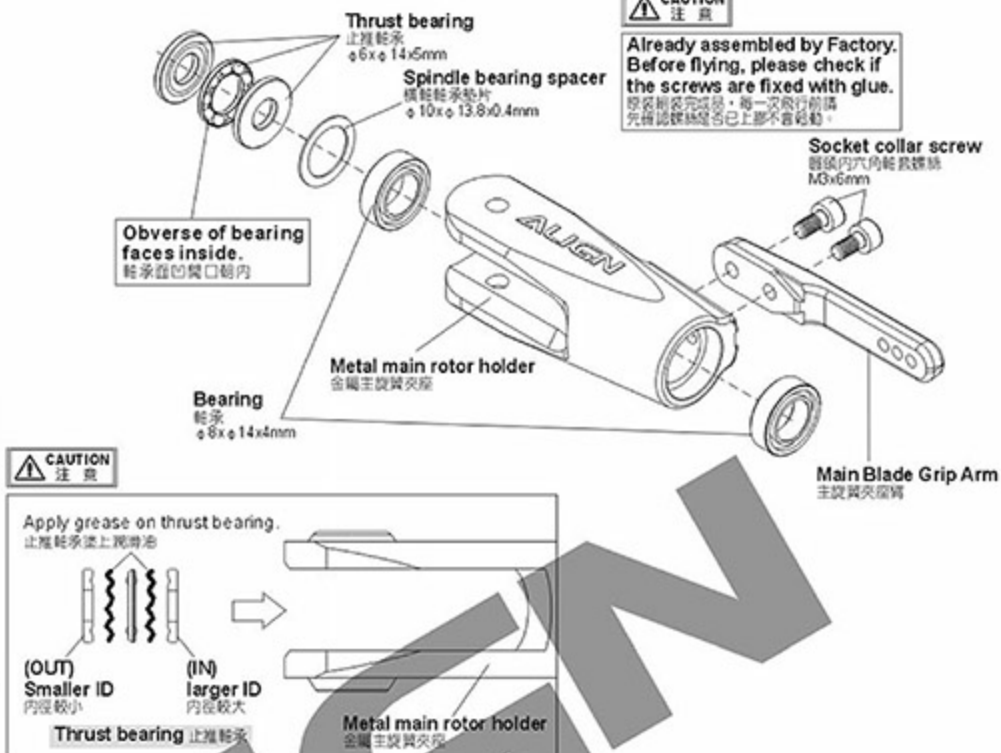

60HH1

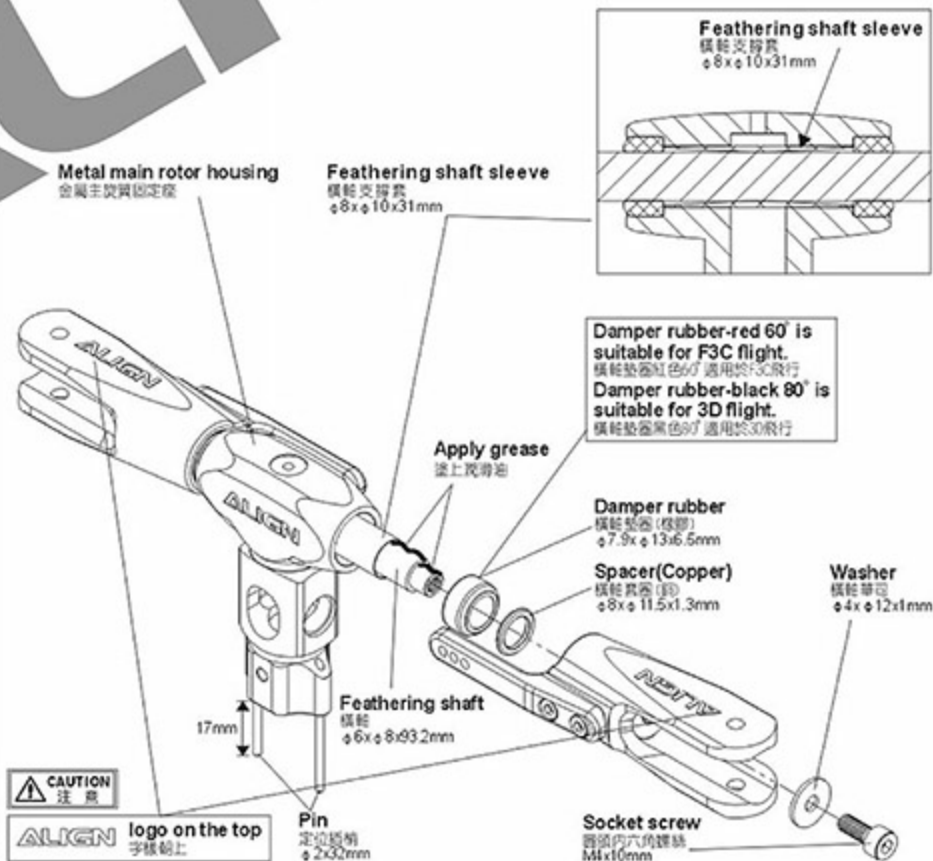

60HH1

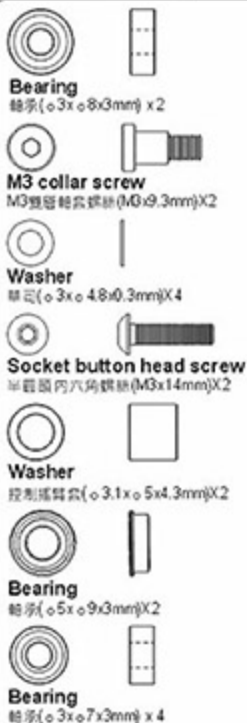

60HH1A

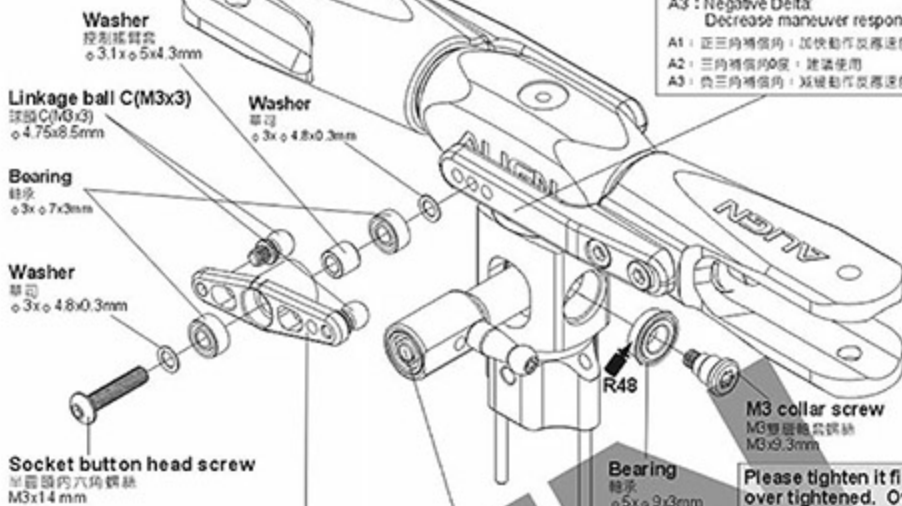

Apply a little amount of T43 thread lock when fixing a metal part.
螺絲鎖附於金屬件請使用適量T43(螺絲膠)

Main blade grip



Please tighten it firmly but not over tightened. Overtightened may cause it strip.
以適當扭力鎖緊即可, 過緊的扭力可能會導致滑牙。

60HZ1



60HZ1



60HT5

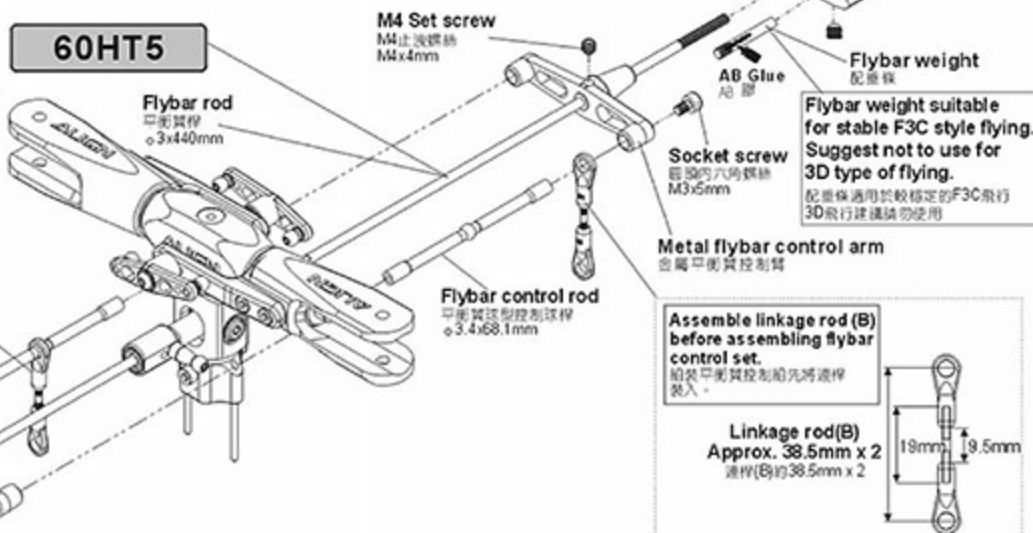

Flybar weight suitable for stable F3C style flying. Suggest not to use for 3D type of flying.
配重珠適用於較穩定的F3C飛行 3D飛行建議請勿使用

60HH3



60HH4



Apply a little amount of T43 thread lock when fixing a metal part.
螺絲鎖附於金屬件請使用適量T43(螺絲膠)

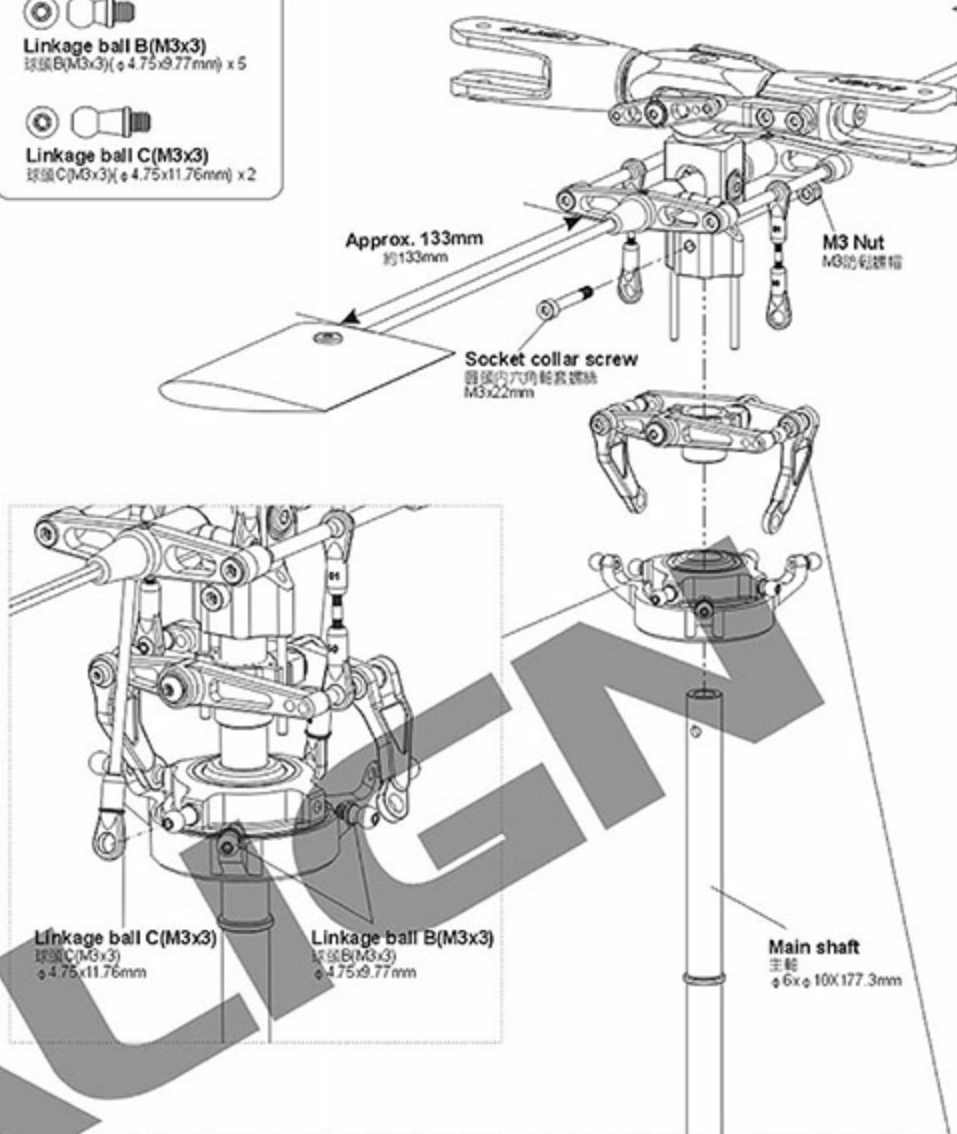

60HH3A



Already assembled by factory.
Before flying, please check if
the screws are fixed with glue.
原裝組裝完成品，每一款飛行前請
先確認螺絲是否已上膠不會鬆動。

Hole A is suitable for F3C flight
Hole B is suitable for 3D flight
A孔適用於F3C飛行
B孔適用於3D飛行

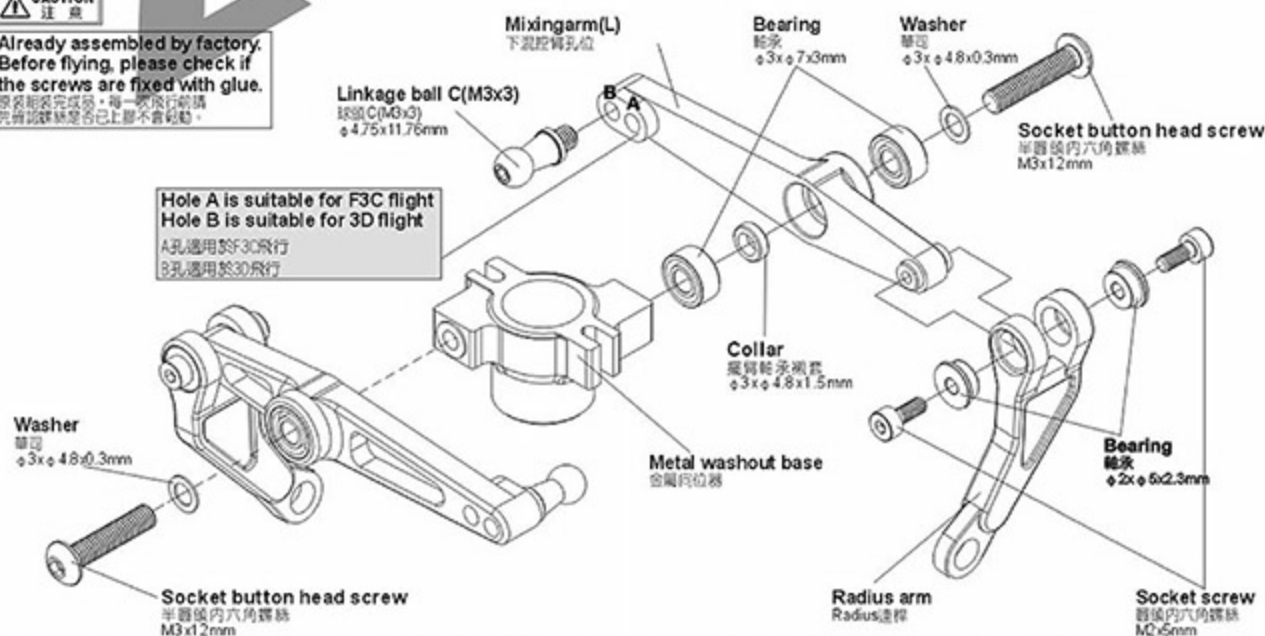

60HZ1

Linkage rod(A)
連桿(A) $\phi 1.96 \times 14 \text{mm} \times 2$

Linkage rod(C)
連桿(C) $\phi 2.5 \times 71 \text{mm} \times 2$

Socket screw
圓錐內六角螺絲
M3 \times 8mm

Metal head stopper
金屬製頭制動器
 $\phi 39 \times 9.26 \text{mm}$

Apply a little amount of T43 thread lock when fixing a metal part.
螺絲鎖附於金屬件時使用適量T43(螺絲膠)

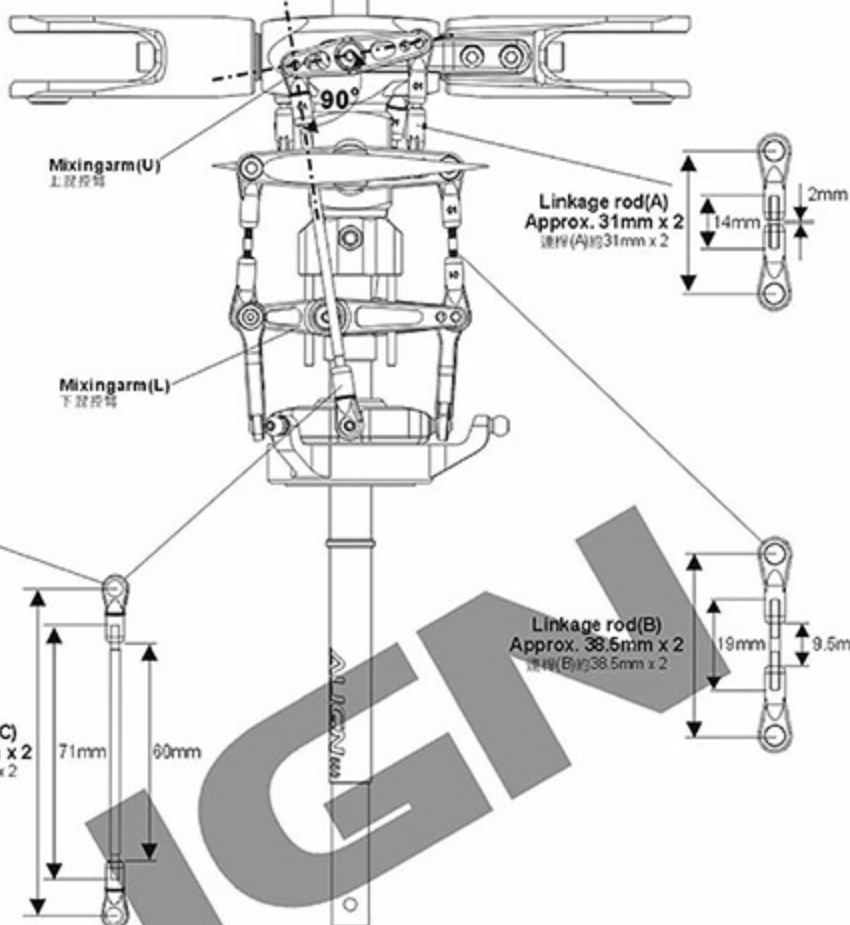

60HZ1A

Ball link For linkage rod(C)
連桿球 x 4 連桿(C)專用

60HZ1A

Ball link
連桿球 x 8

60HH1A

Socket screw
圓錐內六角螺絲(M3 \times 8mm) x 1

Linkage rod(C)
連桿(C) $\phi 89 \text{mm} \times 2$

Effect of Adjustment Mounting Holes 調整孔位影響特性:

Main Blade Grip
主翼夾座螺絲

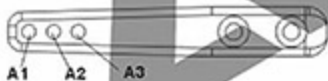

A1: Positive Delta:
Increase maneuver response speed
A2: Zero Delta: Recommended setting
A3: Negative Delta:
Decrease maneuver response speed
A1: 正三角補償角: 加快動作反應速度
A2: 三角補償角0度: 建議使用
A3: 負三角補償角: 減緩動作反應速度

Mixingarm(U)
上混桿孔位



Hole A is suitable for F3C flight
Hole B is suitable for 3D flight
A孔適用於F3C飛行
B孔適用於3D飛行

Mixingarm(L)
下混桿孔位



Hole A is suitable for F3C flight
Hole B is suitable for 3D flight
A孔適用於F3C飛行
B孔適用於3D飛行

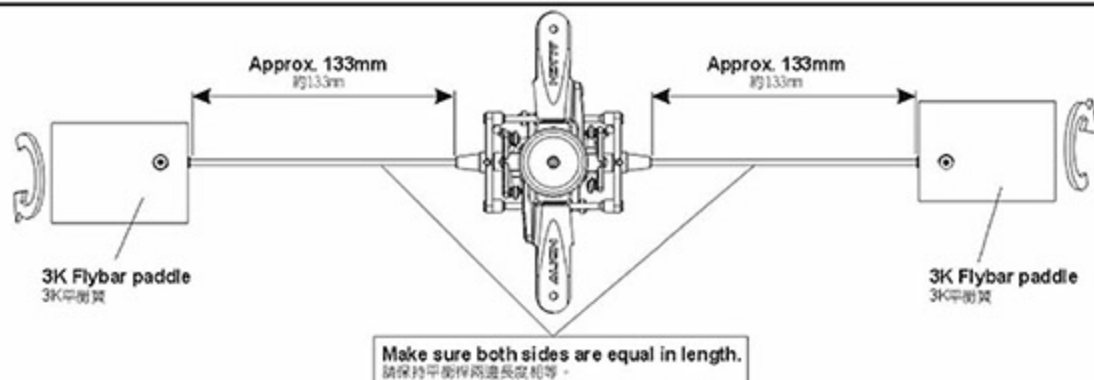

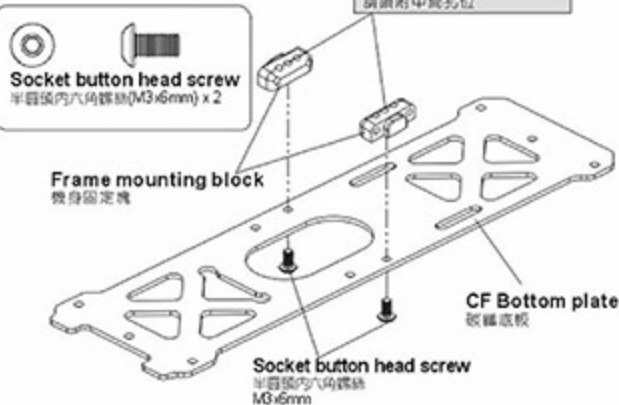
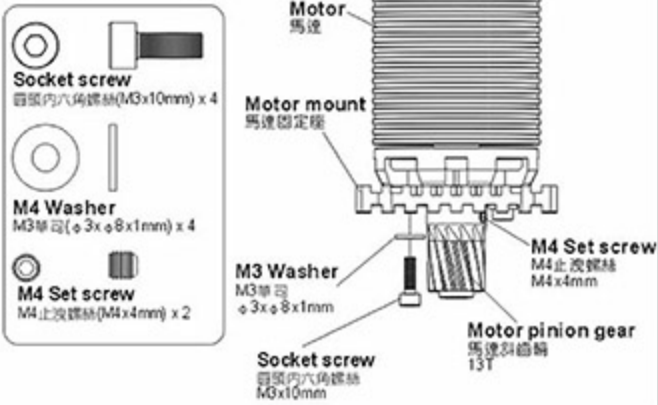
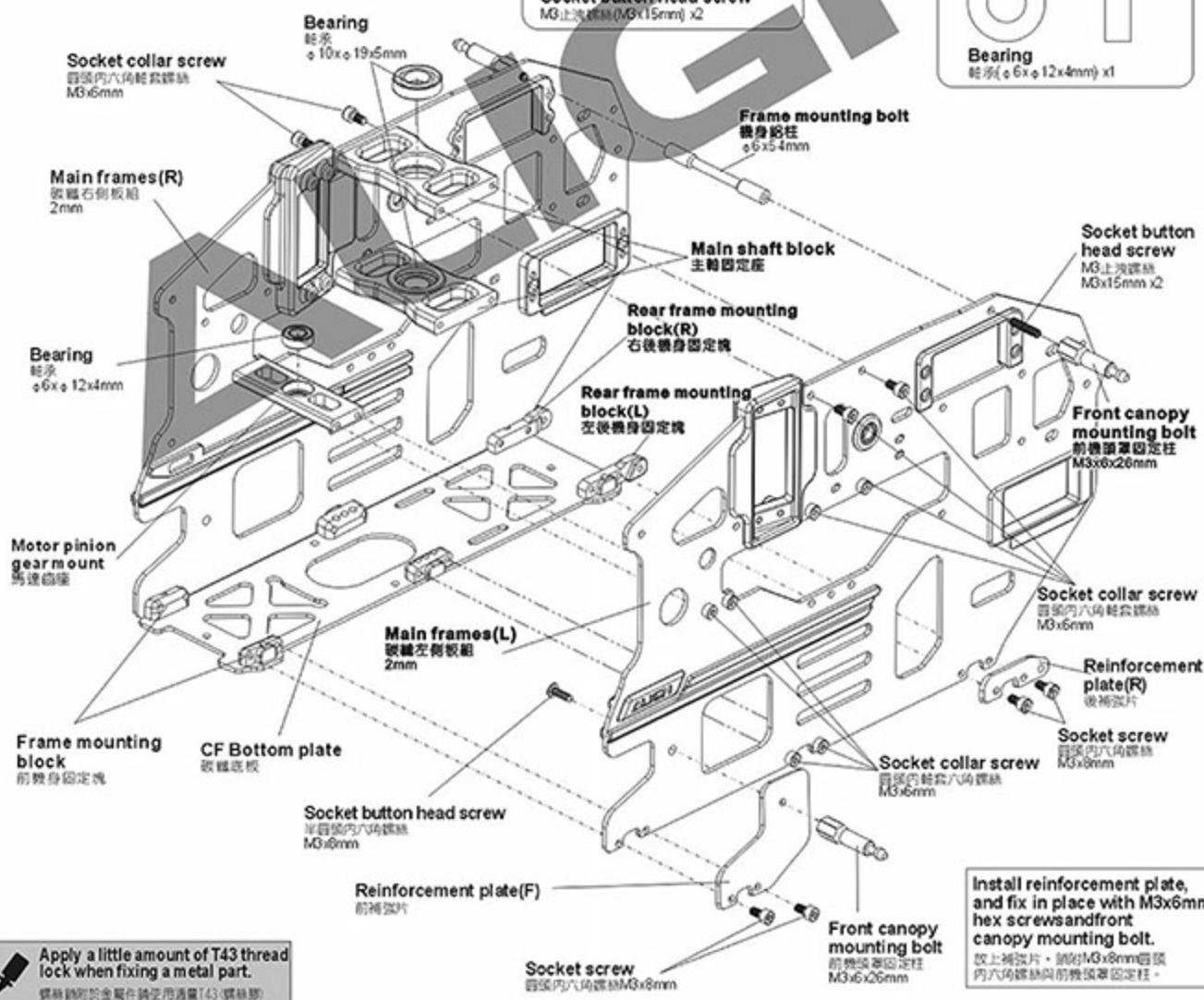
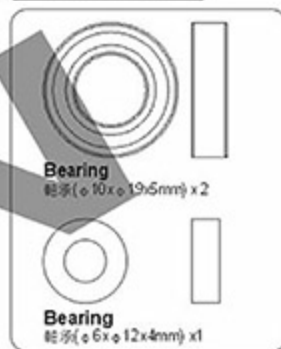
60HB3A**60HM1****60HB3A****60HB4A****60HB3**

Apply a little amount of T43 thread lock when fixing a metal part.
螺絲鎖附於金屬件請使用適量T43(螺絲膠)

Install reinforcement plate, and fix in place with M3x6mm hex screws and front canopy mounting bolt.
裝上補強片，鎖附M3x6mm圓頭內六角螺絲與前機殼蓋固定柱。

Main frame assembly key point :

First do not fully tighten the screws of main frames and put two bearings through the main shaft to check if the movements are smooth. The bottom bracket must be firmly touched the level table top (glass surface) : please keep the smooth movements on main shaft and level bottom bracket, then slowly tighten the screws. This assembly can help for the power and flight performance.

機身側板組立重點：

側板螺絲先不完全鎖緊，放入主軸貫穿二顆軸承確認上下移動必需滑順，主體底板必須與水平桌面（玻璃平面）踏實緊貼，請保持主軸滑順與底板平行桌面後慢慢鎖緊螺絲，正確側板的組裝對動力與飛行性能有顯著幫助。

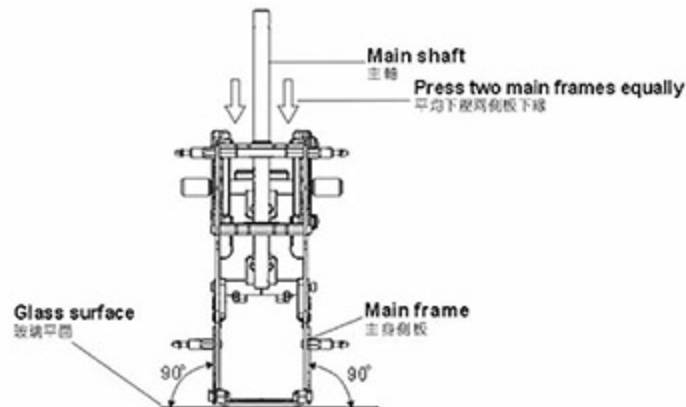

600NG1

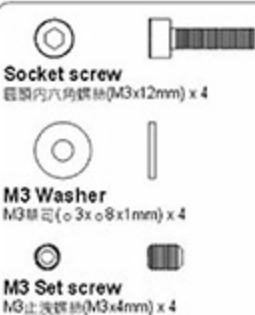

60HB4



60HB4A



60HB3A

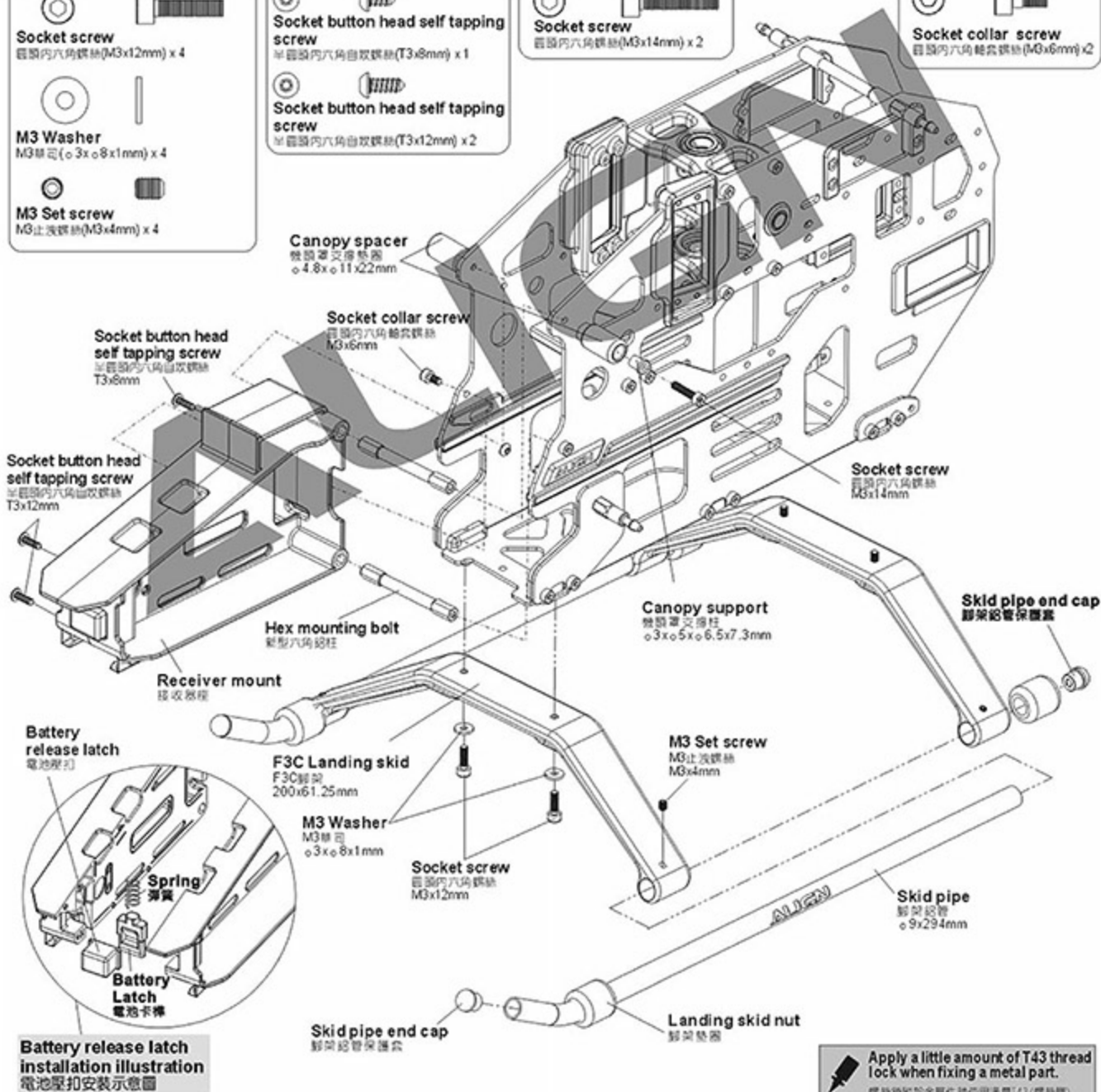

60HZ3

Linkage ball A(M2x3.5)
球頭A(M2x3.5) (φ4.75x8.18mm) x 2

Socket button head self tapping screw
半圓頭內六角自攻螺絲(T2.6x12mm) x 4

M2 Nut
M2螺帽 x 1

Socket button head screw
半圓頭內六角螺絲(M2.5x12mm) x 8

DS610 Digital Servo

- 1.1520 μs standard band / 1520 μs 寬頻系統
- 2.Stall torque/輸出扭力: 9.6kg.cm(4.8V)
12.0kg.cm(6.0V)
- 3.Motion speed/動作速度: 0.10sec/60 (4.8V)
0.08sec/60 (6.0V)
- 4.Dimension/尺寸: 40.3 x 20.1 x 36mm
- 5.Weight/重量: 52.2g

Apply a little amount of T43 thread lock when fixing a metal part.
螺絲鎖於金屬件時使用適量T43(螺絲膠)



CAUTION 注意
3G Flybarless system uses inner hole(A)
Flybar system uses outer hole(B)
3G無平衡翼系統使用內孔(A)
有平衡翼系統使用外孔(B)

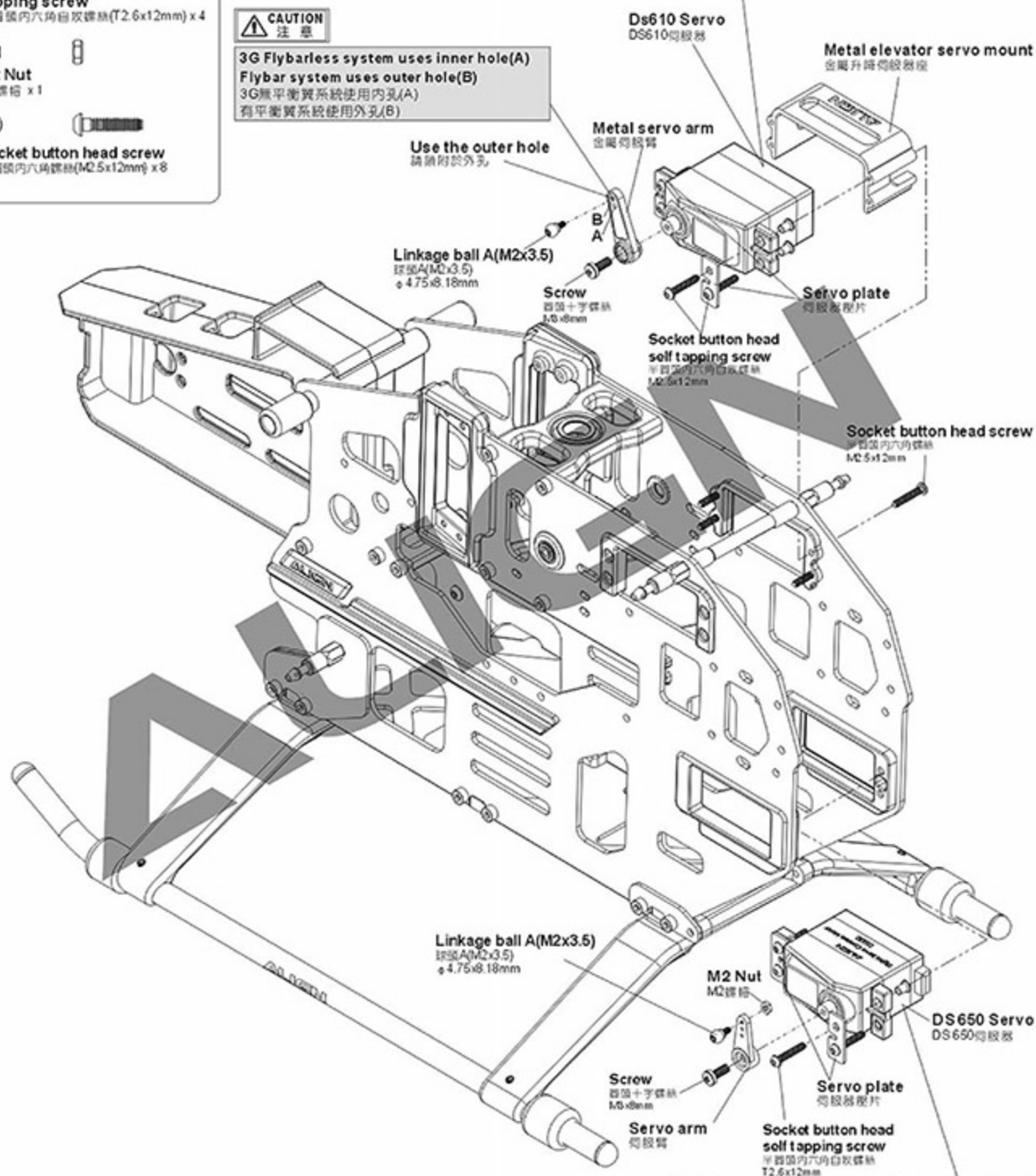

Linkage ball A(M2x3.5)
球頭A(M2x3.5) (φ4.75x8.18mm)

Screw
圓頭十字螺絲
M3x8mm

Socket button head self tapping screw
半圓頭內六角自攻螺絲
M2.5x12mm

Socket button head screw
半圓頭內六角螺絲
M2.5x12mm

Linkage ball A(M2x3.5)
球頭A(M2x3.5) (φ4.75x8.18mm)

Screw
圓頭十字螺絲
M3x8mm

Servo arm
伺服臂

Servo plate
伺服器板片

Socket button head self tapping screw
半圓頭內六角自攻螺絲
T2.6x12mm

DS650 Digital Servo

- 1.1520 μs standard band / 1520 μs 寬頻系統
- 2.Stall torque/輸出扭力: 4.0kg.cm(4.8V)
5.0kg.cm(6.0V)
- 3.Motion speed/動作速度: 0.058sec/60 (4.8V)
0.048sec/60 (6.0V)
- 4.Dimension/尺寸: 40.3 x 20.1 x 36mm
- 5.Weight/重量: 56g

Recommend sanding the marked position as below illustration with a waterproof abrasive paper(#800-1000) to avoid the wires of electric parts to be cut.

建議於下圖色塊標示處，使用#800-1000水砂紙打磨，可防止電子設備電線被刮破。

Waterproof abrasive paper
水砂紙



CAUTION
注意

Make sure the motor mount is fully fastened before fasten the motor pinion gear mount.

先將馬達固定座鎖緊固定後，再將馬達齒輪鎖緊。

60HB3A



Socket collar screw
圓錐內六角輪套螺絲(M3x6mm) x 4

60HZ3



Short linkage ball A(M2X3)
短球頭A(M2X3)(ϕ 4.75x13.5mm)x2



Long linkage ball A(M2X3)
長球頭A(M2X3)(ϕ 4.75x18mm)x2



Socket button head self tapping screw
半圓錐內六角自攻螺絲(T2.6x12mm) x 8

CAUTION
注意

3G Flybarless system uses inner hole(A)
Flybar system uses outer hole(B)

Please make sure there is no interference when you install linkage ball. You can choose to install with the long linkage ball A or short linkage ball A when using outer hole B. Please only use short linkage ball A when using inner hole A.

安裝球頭時請確認動作無干涉。使用外孔B時，可選擇安裝長球頭A或短球頭A；使用內孔A時，僅限安裝短球頭A。

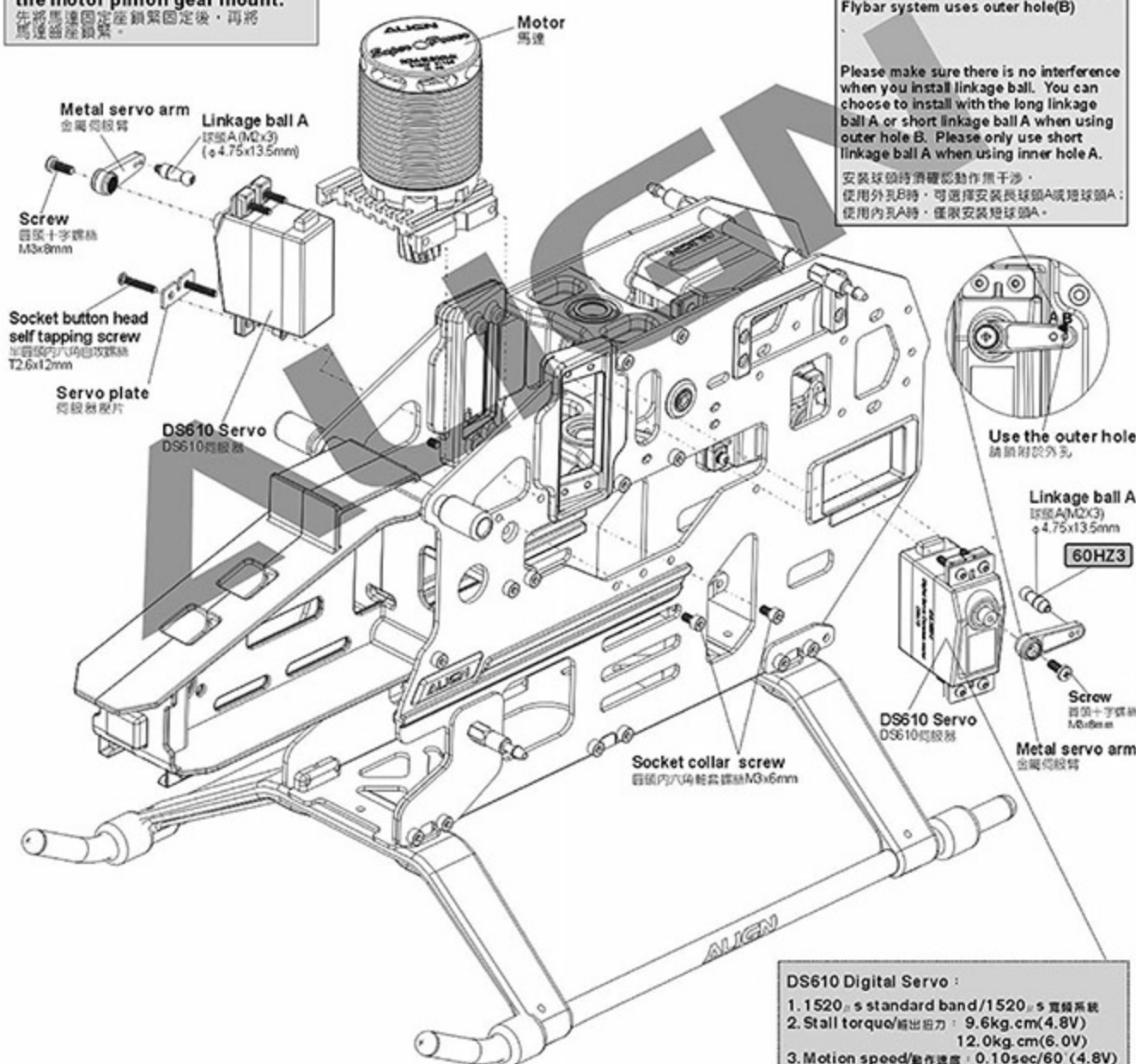

Metal servo arm
金屬伺服臂

Linkage ball A
球頭A(M2x3)
(ϕ 4.75x13.5mm)

Screw
圓頭十字螺絲
M3x8mm

Socket button head self tapping screw
半圓錐內六角自攻螺絲
T2.6x12mm

Servo plate
伺服板板片

DS610 Servo
DS610 伺服器

Motor
馬達

Use the outer hole
請針對外孔

Linkage ball A
球頭A(M2x3)
 ϕ 4.75x13.5mm

60HZ3

Screw
圓頭十字螺絲
1.6x8mm

Metal servo arm
金屬伺服臂

Socket collar screw
圓錐內六角輪套螺絲M3x6mm

DS610 Servo
DS610 伺服器

DS610 Digital Servo :

1. 1520 μ s standard band / 1520 μ s 寬頻系統
2. Stall torque/輸出扭力 : 9.6kg.cm(4.8V)
12.0kg.cm(6.0V)
3. Motion speed/動作速度 : 0.10sec/60 (4.8V)
0.08sec/60 (6.0V)
4. Dimension/尺寸 : 40.3 x 20.1 x 36mm
5. Weight/重量 : 52.2g

Apply a little amount of T43 thread lock when fixing a metal part.

螺絲鎖於金屬件請使用適量T43(螺絲膠)

60HB3



60HB3A



60HZ1



60HZ1A

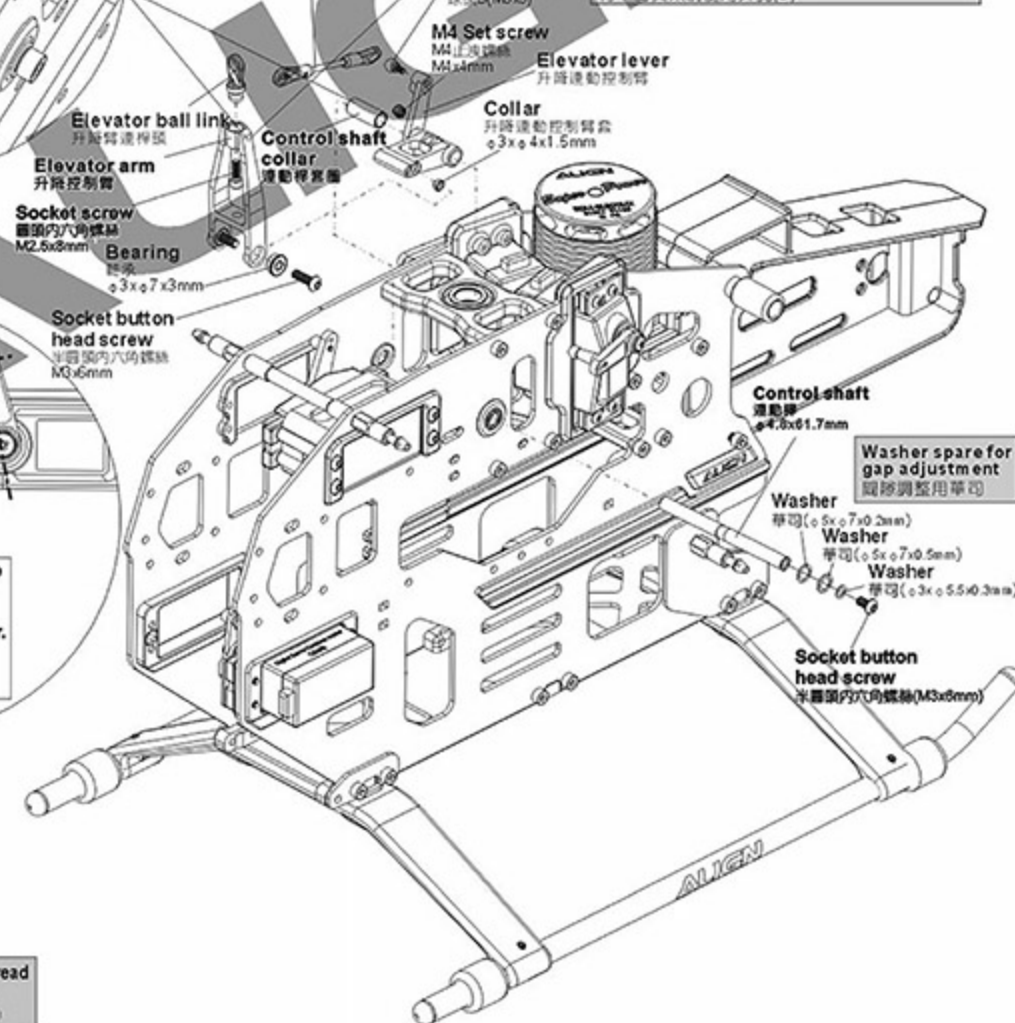
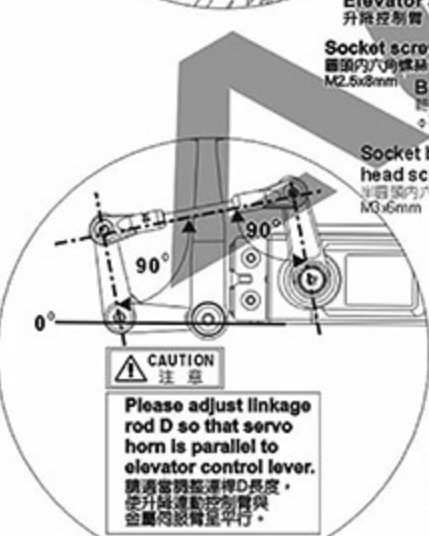
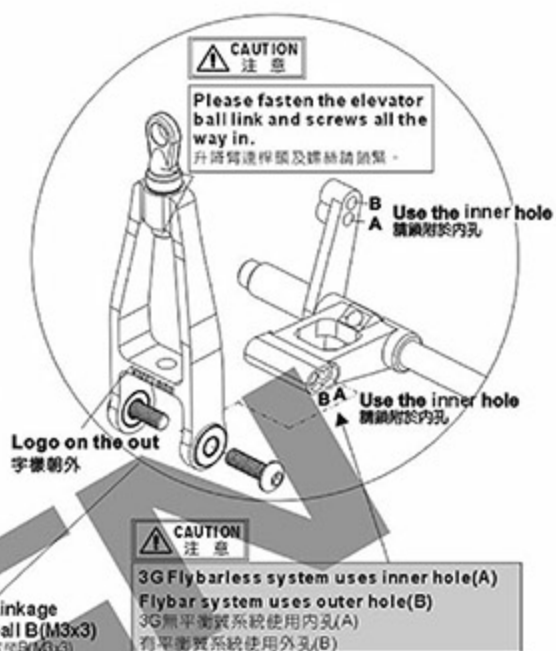
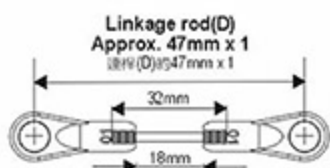
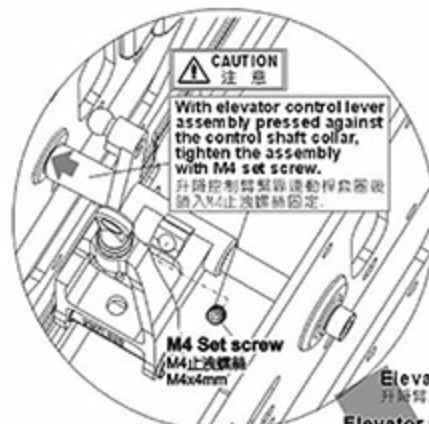

Apply a little amount of T43 thread lock when fixing a metal part.
螺絲鎖於金屬件請使用適量T43(螺絲膠)

60HT1

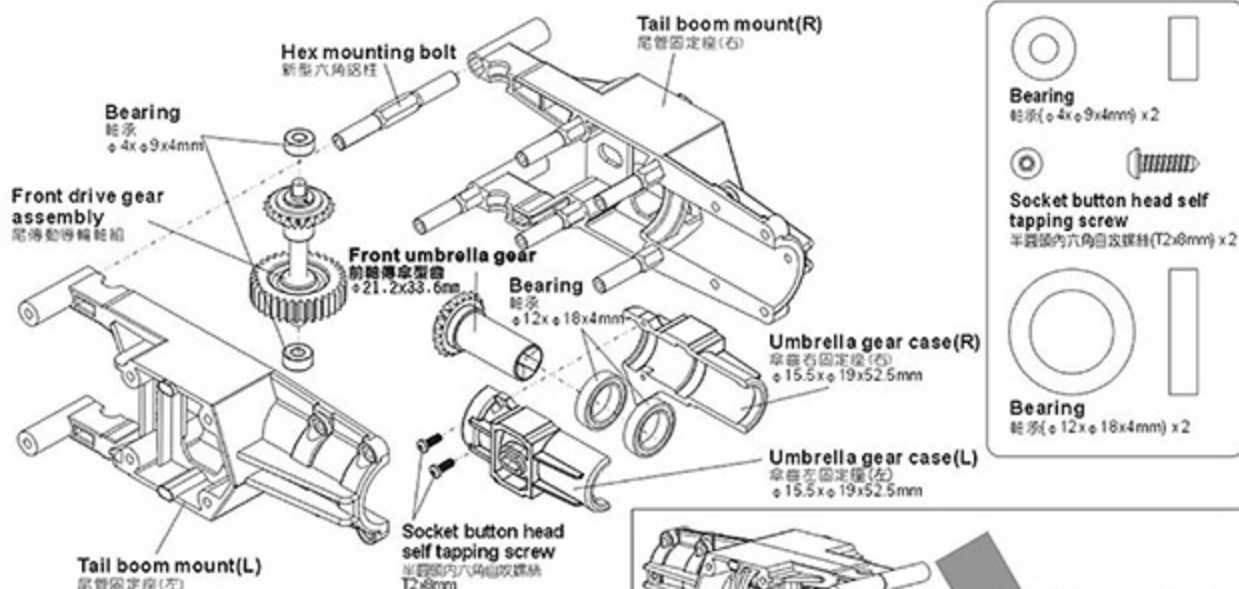

Bearing
軸承(φ4x9x4mm) x2

Socket button head self tapping screw
半圓頭內六角自攻螺絲(T2x6mm) x2

Bearing
軸承(φ12x18x4mm) x2

60HT2

Apply a little amount of T43 thread lock when fixing a metal part.
螺絲鎖於金屬零件時使用適量T43(螺絲膠)

Socket screw

圓頭內六角螺絲(M3x20mm)x1

Bearing

軸承(φ12x18x4mm) x2

Tail umbrella gear

尾傘齒輪組
φ12.4x18x10mm x1

Bearing

軸承(φ5x10x4mm) x2

Socket screw

圓頭內六角螺絲(M3x6mm)x4

Torque tube drive tail unit
尾管傳動齒箱
φ18x27x53mm

Bearing

軸承
φ12x18x4mm

Tail umbrella gear

尾傘齒輪組
φ21.2x24.65mm

Tail umbrella gear

尾傘齒輪組
φ12.4x18x10mm

Tail rotor shaft assembly

尾旋輪軸

Socket screw
圓頭內六角螺絲
M3x6mm

Metal plate (R)

尾齒箱右側板
40.3x13.5mm

Socket screw

圓頭內六角螺絲
M3x6mm

Socket screw

圓頭內六角螺絲
M3x20mm

Metal plate (L)

尾齒箱左側板
40.3x14.5mm

Bearing

軸承
φ5x10x4mm

60HT2

Apply a little amount of T43 thread lock when fixing a metal part.
螺絲鎖於金屬件時使用適量T43(螺絲膠)



Socket screw
圓錐內六角螺絲(M3x8mm) x 2



Linkage ball A
球頭A(M2x3.5)(φ4.75x8.18mm) x 1



Collar screw
軸套螺絲(M2x8mm)(牙長3mm) x 2



Thrust bearing
止推軸承(φ5xφ10x4mm) x 2



Socket collar screw
圓錐內六角軸套螺絲(M3x15mm) x 1



Collar screw
軸套螺絲(牙長4.3mm) x 2



Washer
華司(φ3xφ4.8x0.3mm) x 2



Collar A
尾速桿鎖緊套A(φ2xφ3x4mm) x 2

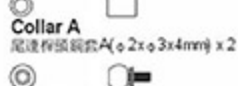

Linkage ball A
球頭A(M2x2.5)(φ4.75x7.18mm) x 1



Bearing
軸承(φ5xφ10x4mm) x 2



Washer
華司(φ3xφ4.8x0.3mm) x 2



Collar
尾速桿鎖緊套(φ7xφ8.3x3.5mm) x 1



Bearing
軸承(φ3xφ6x2.5mm) x 2



Collar
尾旋翼控制臂球套(φ3xφ4.9x5mm) x 1



Bearing
軸承(φ7xφ11x3mm) x 2

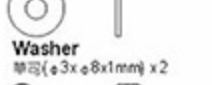

Washer
華司(φ3xφ8x1mm) x 2



Tail pitch bell crank sleeve
尾旋翼控制臂球套(φ7.6xφ4.7x6.2mm) x 1



Slide shaft
尾軸滑套(φ8xφ7x17.6mm) x 1



M4 Set screw
M4止波螺絲(M4x4mm) x 1



Tail rotor holder
尾旋翼夾座



Tail rotor hub
尾旋翼1型座(φ10x39mm)

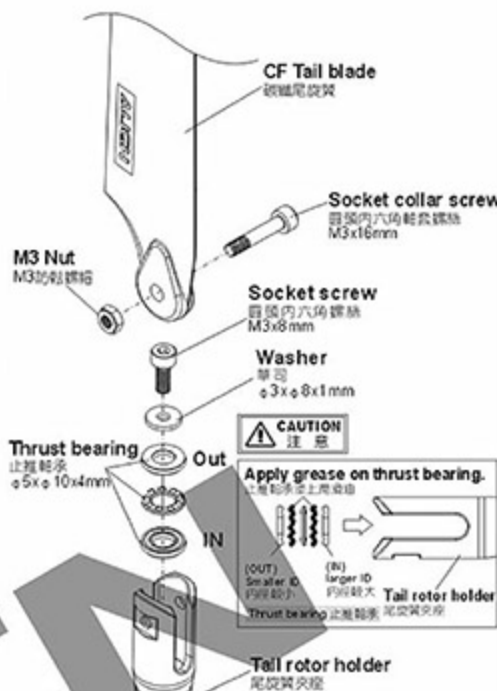

CAUTION
注意

Apply grease on thrust bearing.
在軸承滾道上塗油

(OUT) Smaller ID 內徑較小
(IN) Larger ID 內徑較大

Thrust bearing 止推軸承
Tail rotor holder 尾旋翼夾座

CAUTION
注意

While assembly the slide shaft, please use suitable amount of T43 on the thread. Please do not use R48 anaerobics retainer or other high strength glue to avoid damages while maintenance or repairs.
組立尾軸滑套時，請使用適量的T43螺絲膠在螺絲上。嚴禁使用R48高膠合性軸承膠防止膠合過緊，以避免日後維修總裝零件之損傷。

Aim tail rotor hub at the concave of tail rotor shaft and fix it, please apply a little glue on the set screw.
尾旋翼1型座應準尾旋翼軸的凹面並鎖上，請確認上波螺絲上膠。

Assembling Umbrella Gear: Please note to push the gear to the end at a fixed position, to make sure the gears mesh with each other smoothly.
傘齒組裝：注意務必將齒推到固定位置，以免齒咬合不順暢。

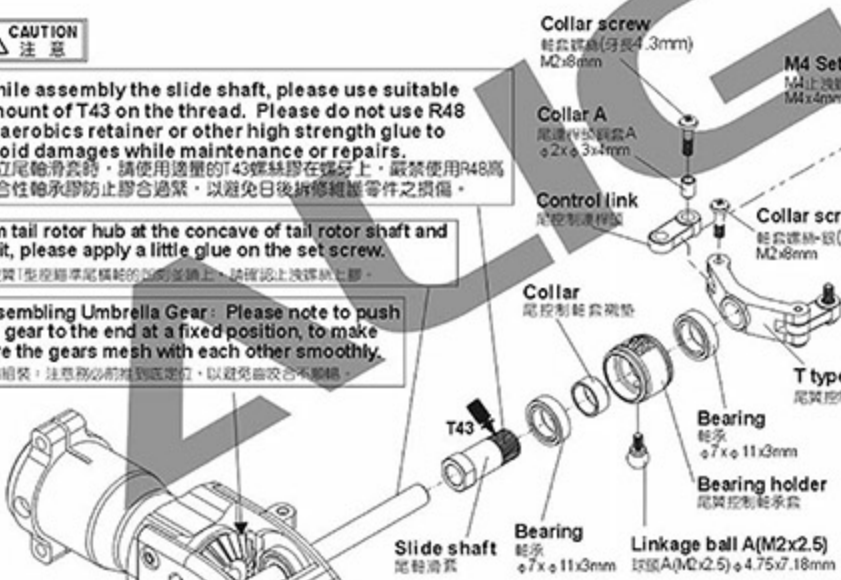

60HT2A

Socket collar screw
圓錐內六角軸套螺絲(M3x16mm) x 2

M3 Nut
M3的鎖螺帽 x 2

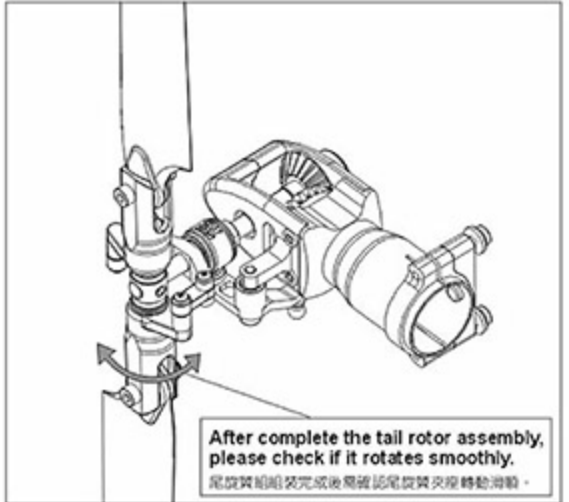
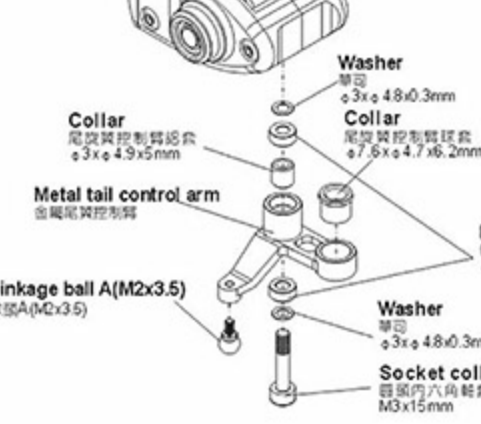

After complete the tail rotor assembly, please check if it rotates smoothly.
尾旋翼組裝完成後應確認尾旋翼夾座旋轉滑動。

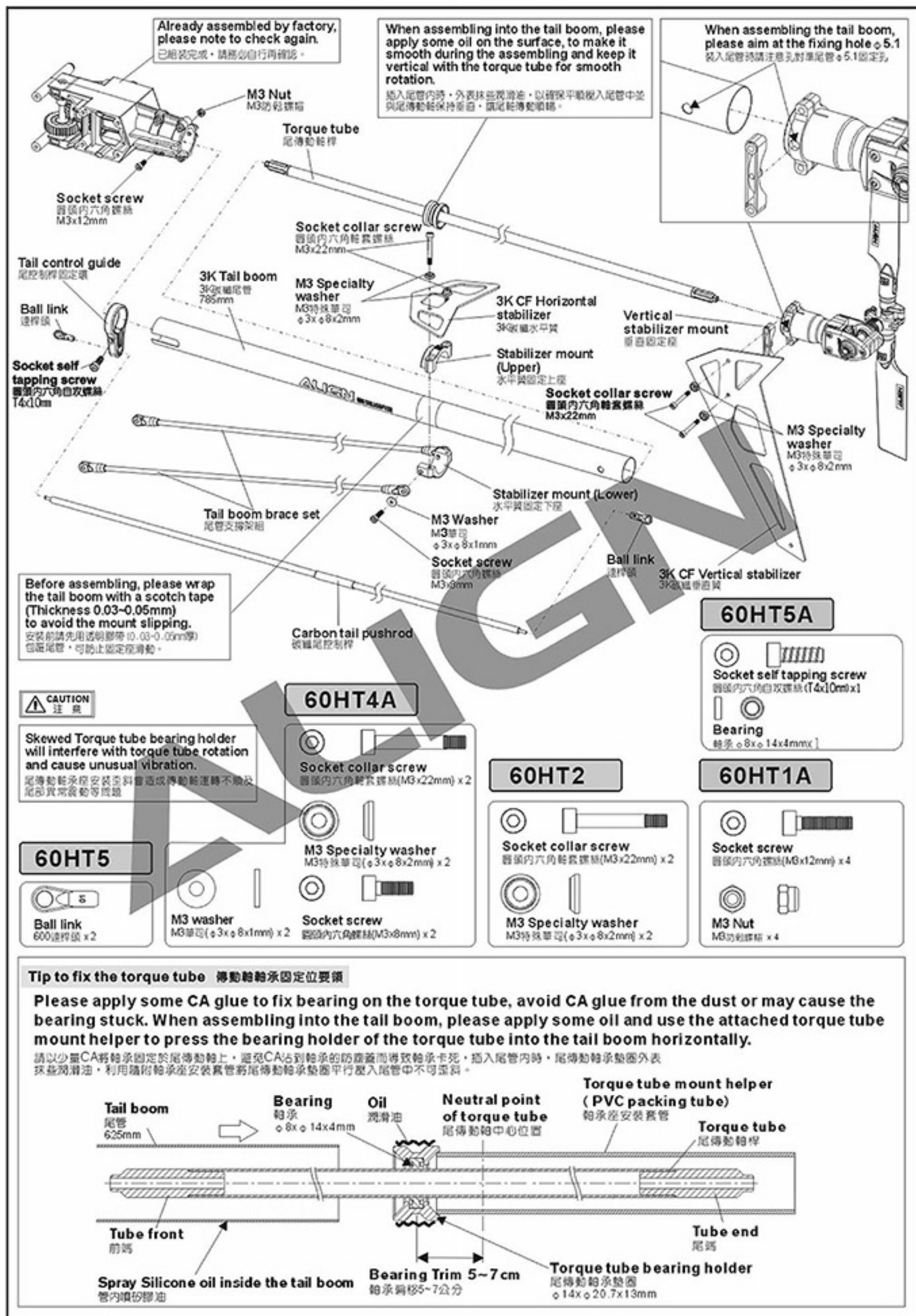

Apply a little amount of T43 thread lock when fixing a metal part.
螺絲鎖附於金屬件請使用適量T43螺絲膠

60HB3A



Socket screw
普通內六角螺絲(M3x12mm) x 2



M4 Washer
M4華司(φ3xφ8x1mm) x 2

60HT1A



Socket screw
普通內六角螺絲(M3x10mm) x 12



Socket button head screw
半圓頭內六角螺絲(M3x5mm) x 1

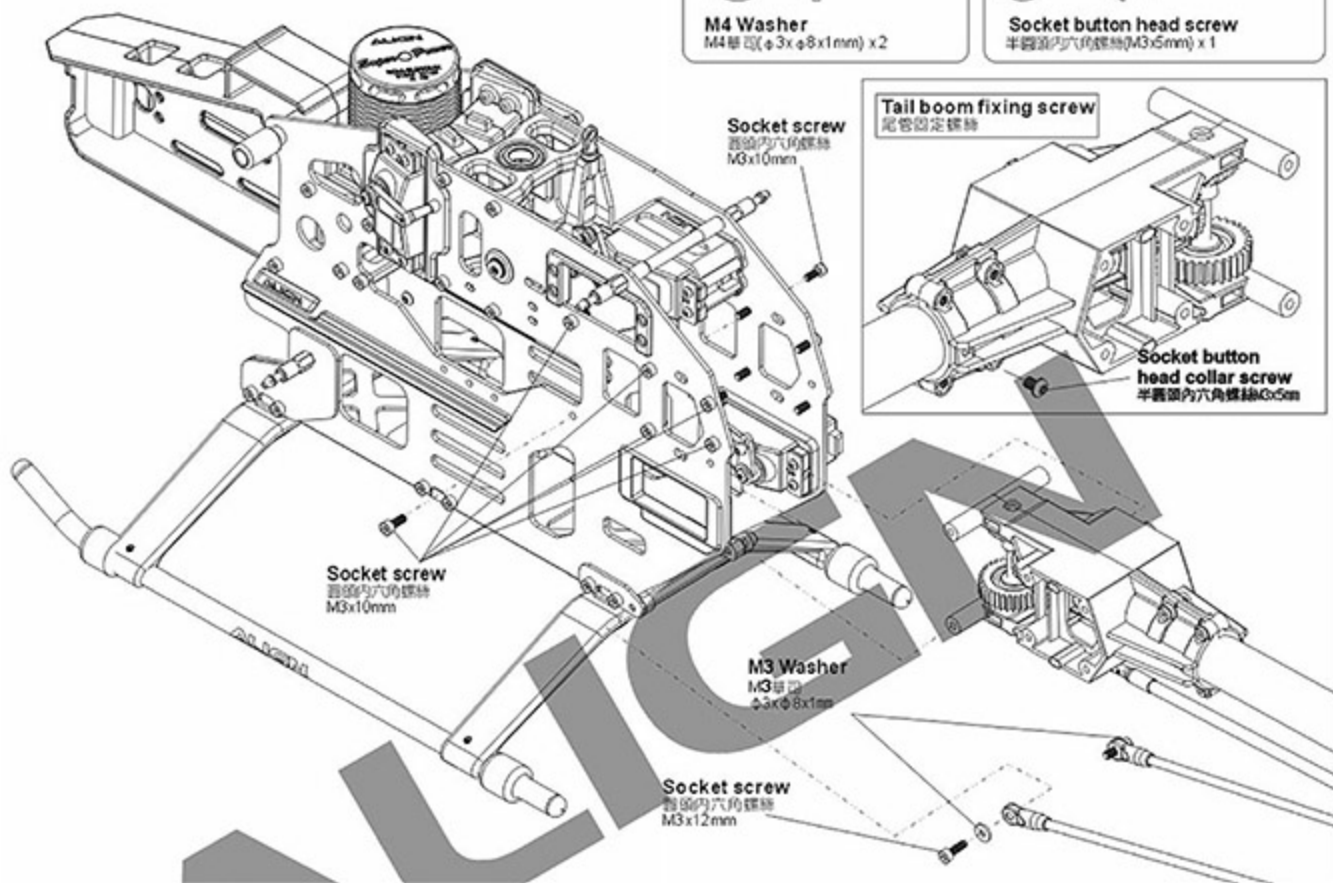

60HB5



Bearing
軸承(φ12xφ18x4mm) x 1



One-way bearing
單向軸承(φ12xφ18x16mm) x 1



Washer
華司(φ11.5xφ18x0.8mm) x 1



One-way bearing shaft
單向軸承華司(φ9xφ12x34.7mm)X1

Before tightening the screw, please rotate the bearing and check the concentricity of the bearing. Then apply some glue evenly on the screw and tighten it firmly, to avoid the bearing stuck or heavy load at one side and cause slip.
上緊螺絲前請以轉動軸承檢查同心度良好後，才能將螺絲平均上膠鎖緊，以避免
螺絲鎖緊後造成軸承卡死或重負荷於一側造成打滑。

CAUTION
注意

Already assembled by factory.
Before flying, please check if the screws are fixed with glue.
原裝組裝完成品，第一次飛行前請先確認螺絲是否已上膠不會鬆動。

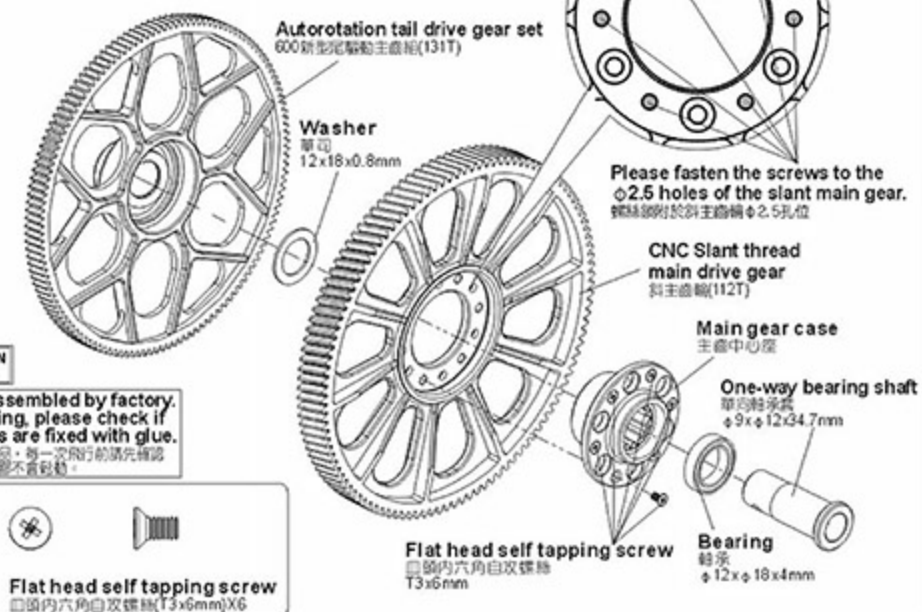

7. Battery installation illustration 電池安裝示意圖

ALIGN

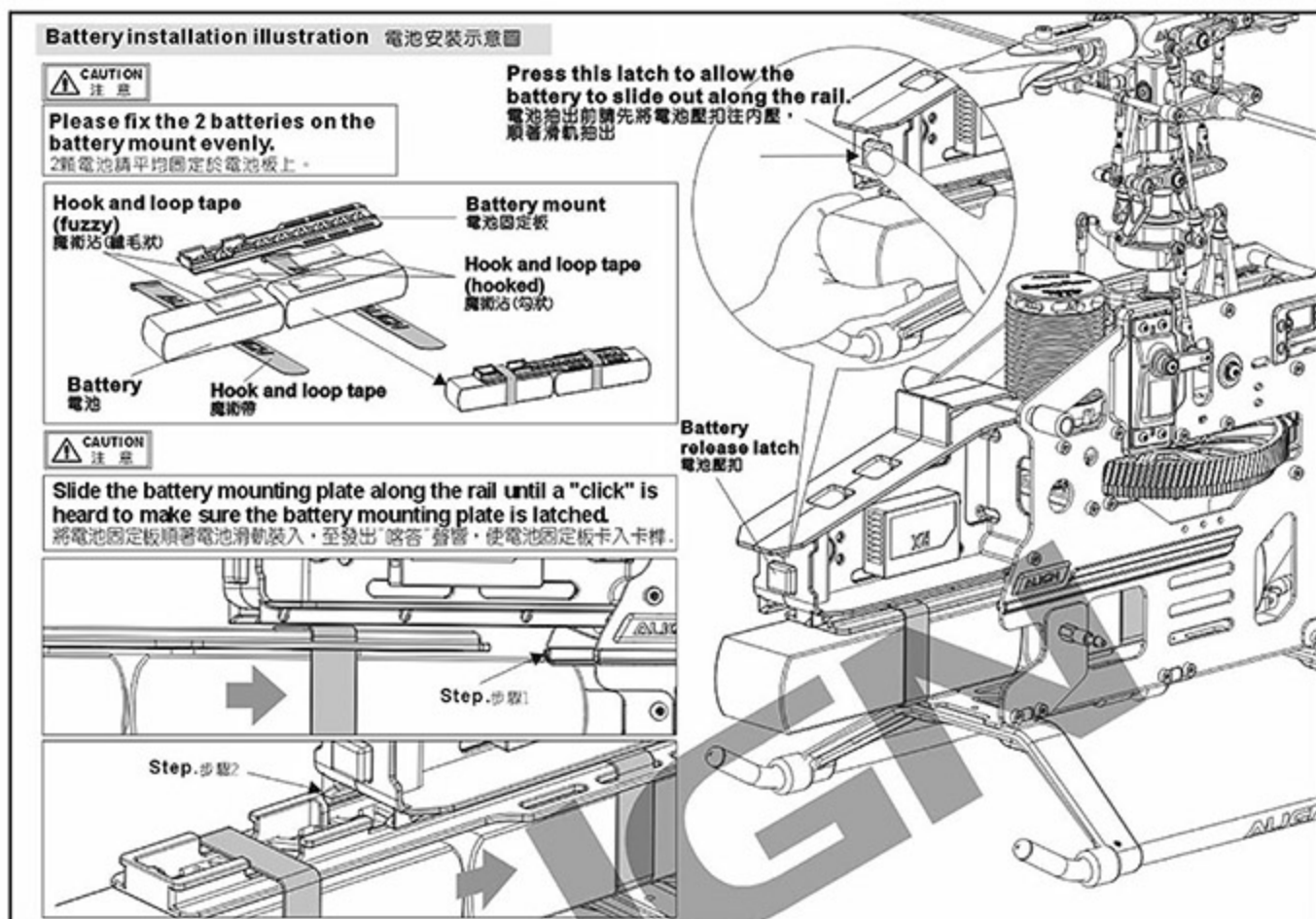

8. EQUIPMENT INSTALLATION 各項設備配置圖

ALIGN

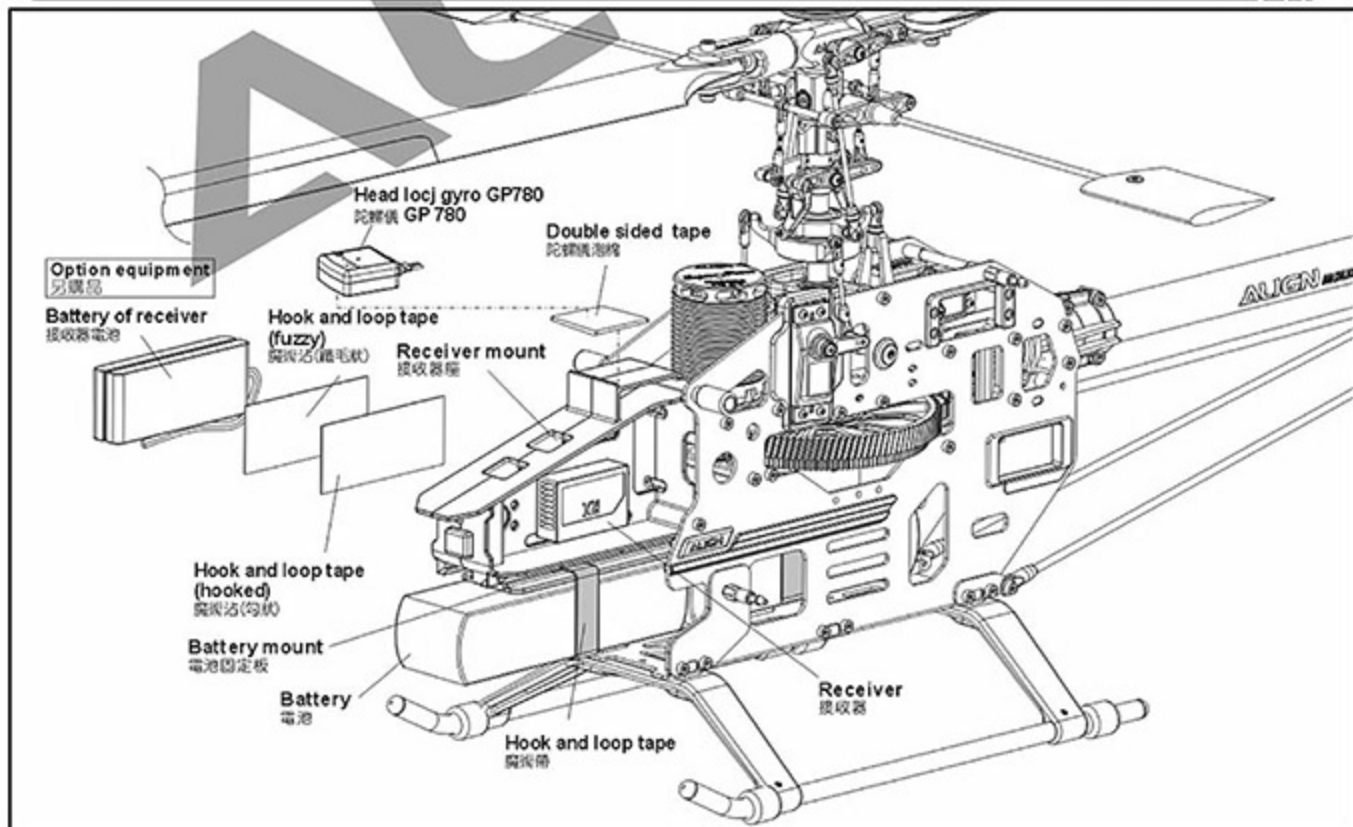

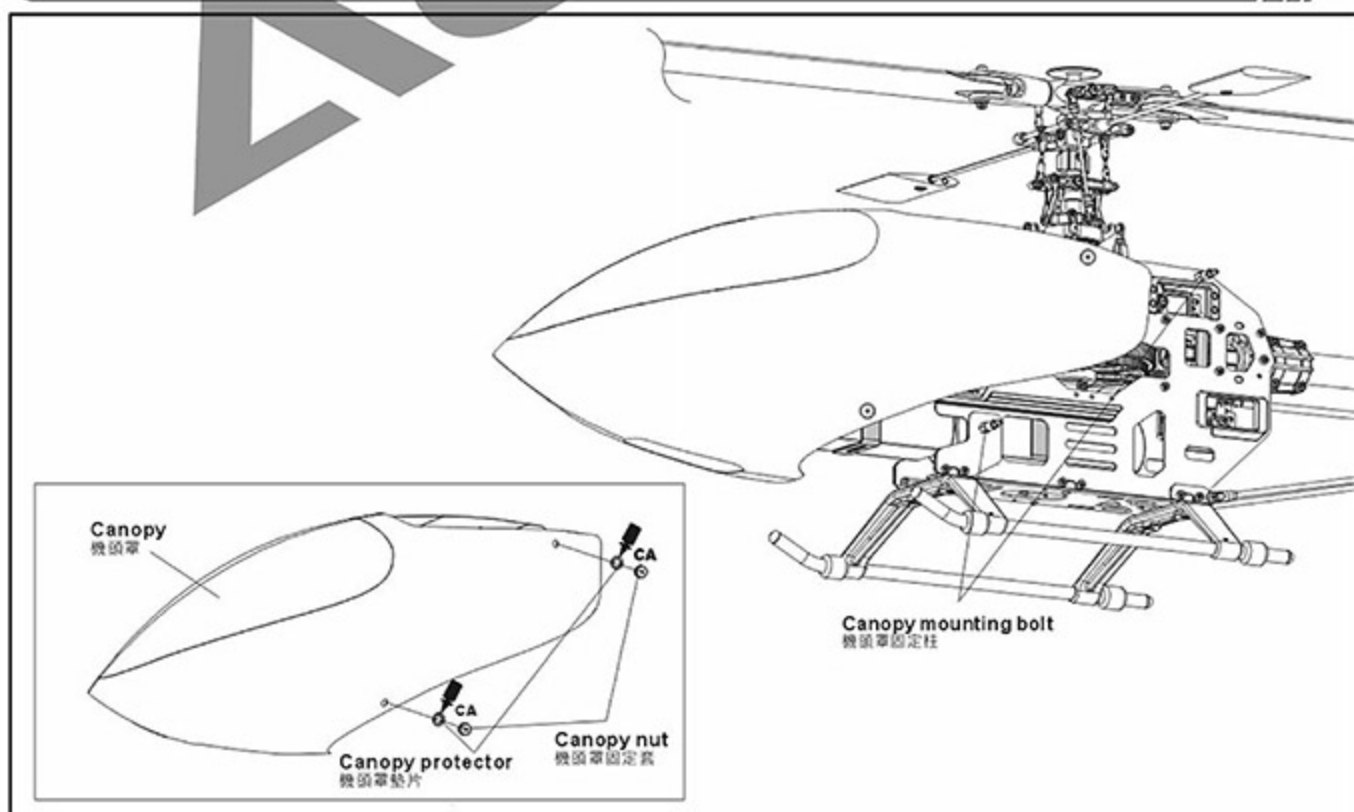
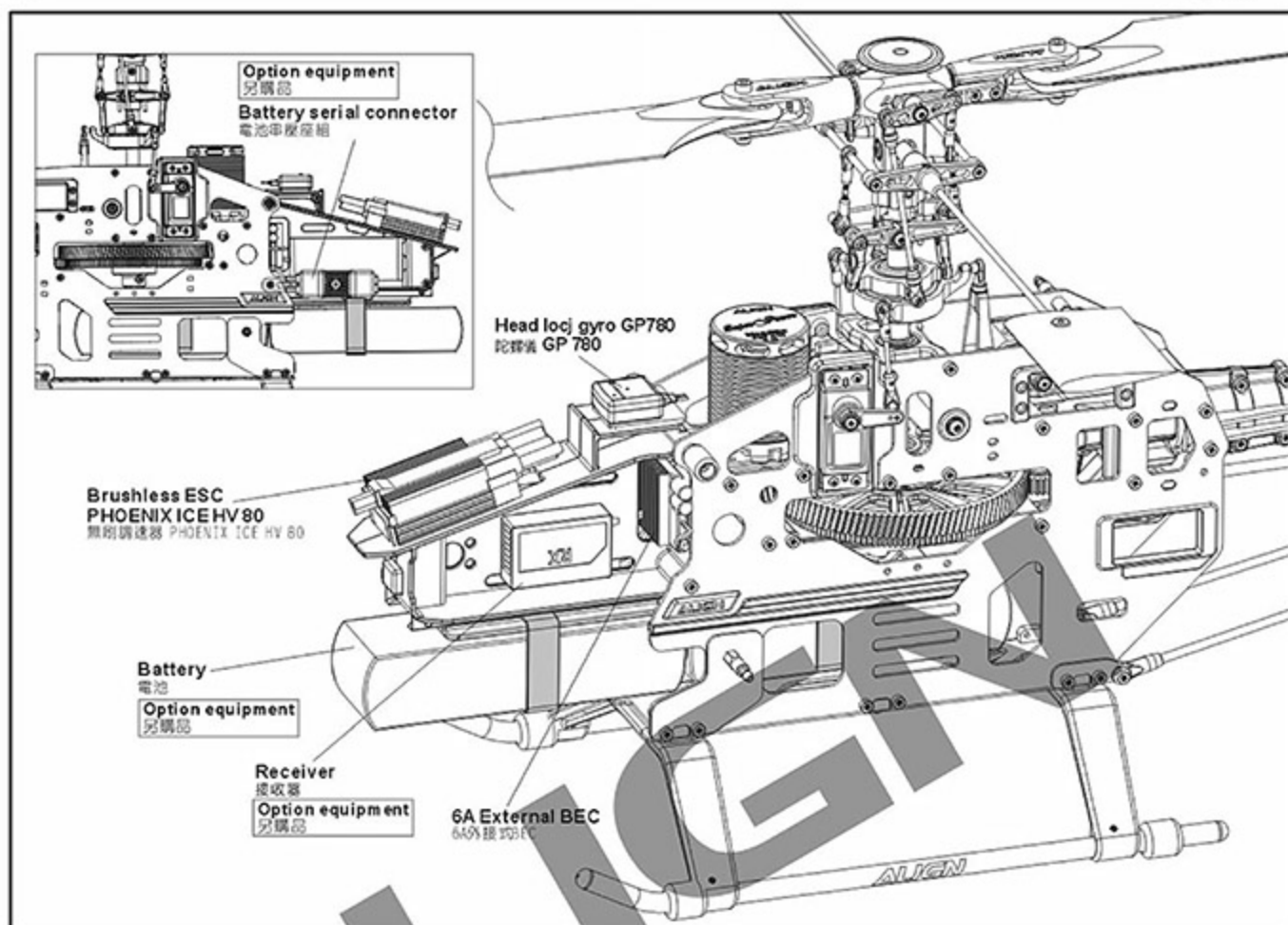

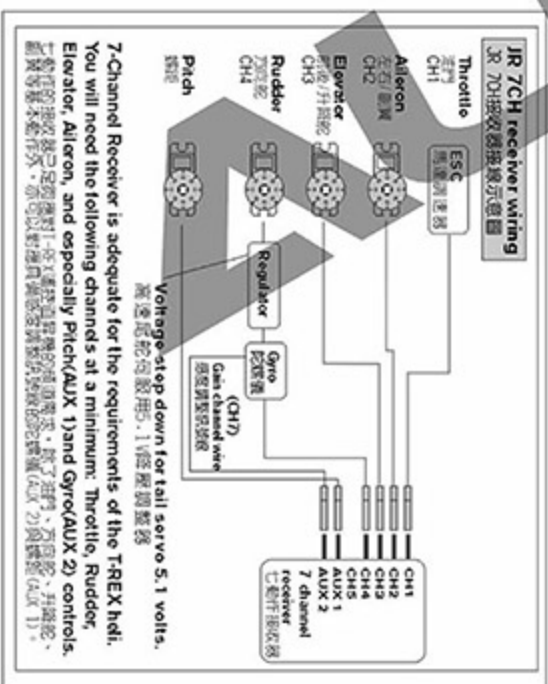
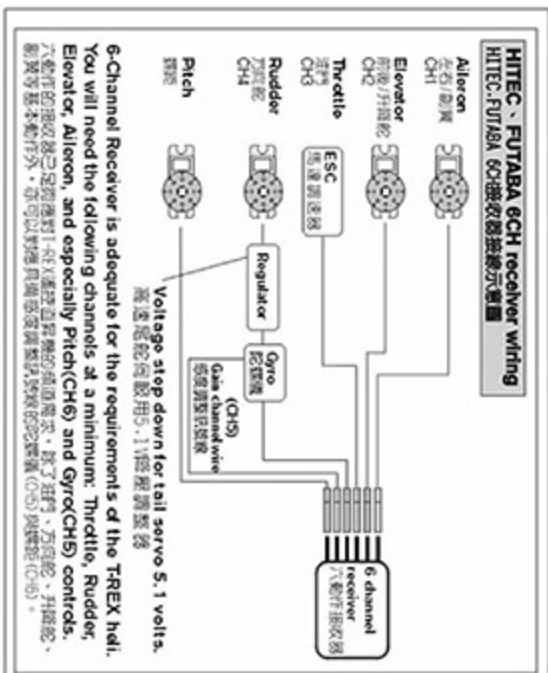
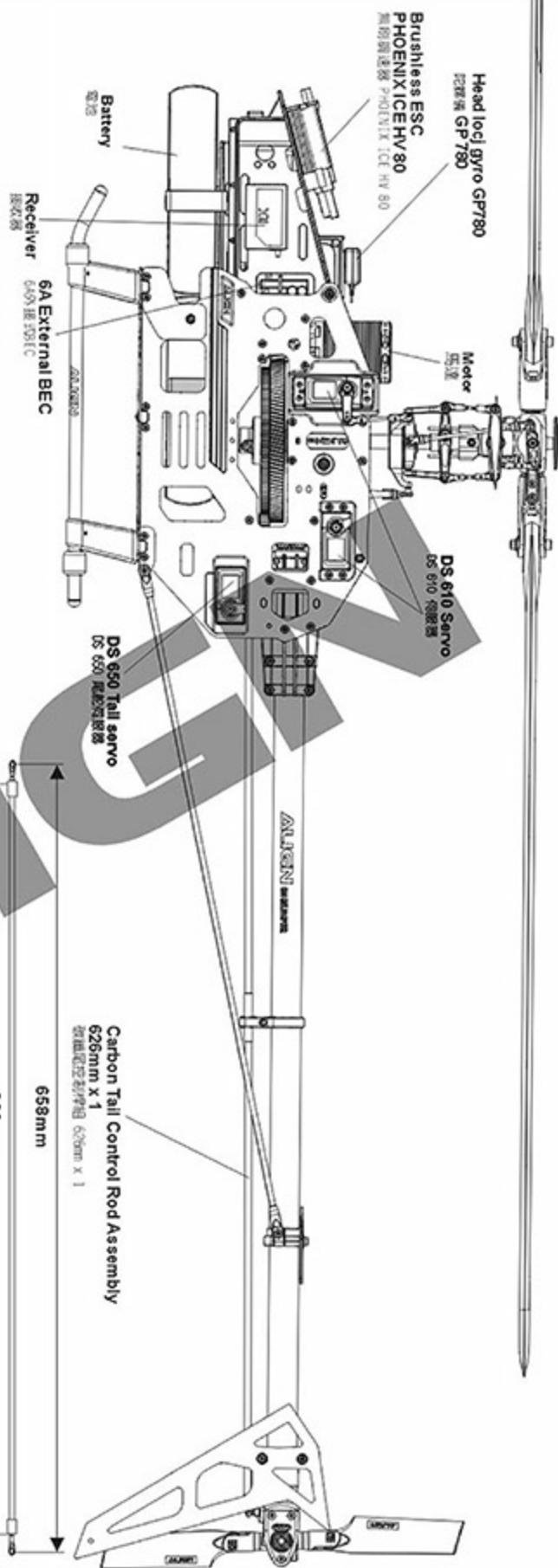

To set this option is to turn on the transmitter and connect to BEC power.

此項設定只要開啓發射器，接上BEC電源即可進行操作。

JR Transmitter/Servo JR遙控器對應伺服器關係

Aileron:CH2 Pitch:CH6
副翼:CH2 螺距:CH6

Pitch:CH6 Aileron:CH2
螺距:CH6 副翼:CH2

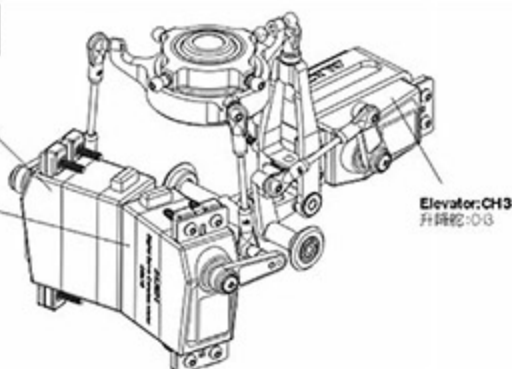

Elevator:CH3
升降舵:CH3

Positions of CH2 · CH6 are exchangeable, After assembling as photo (Note: Set the transmitter under CCPM 120 degrees mode), pull throttle stick (pitch) upward. If one swashplate servo (or two servos) moves downward, adjust reverse switch (REV) on the transmitter to make it moves upward. If three servo move downward, adjust the travel value (+) of SWASH CH6 on the transmitter to make them move upward. When the actions of Aileron and Elevator are opposite, adjust travel values of SWASH CH2 and CH3.

CH2 · CH6可互換位置，依圖安裝(注意：遙控器設定於CCPM 120°之設定模式，將副翼桿向上推，若單一螺距伺服器有向下移動，請調整接收器的反轉開關(REV)使副翼向上，若三個螺距伺服器均有向下移動，請調整接收器SWASH CH6行程量的正負值，使副翼與螺距向上移動，副翼與升降舵相反時，同樣調整 SWASH CH2 · CH3行程量正負值。

FUTABA/HITEC Transmitter/Servo FUTABA/HITEC遙控器對應伺服器關係

Aileron:CH1 Pitch:CH6
副翼:CH1 螺距:CH6

Pitch:CH6 Aileron:CH1
螺距:CH6 副翼:CH1

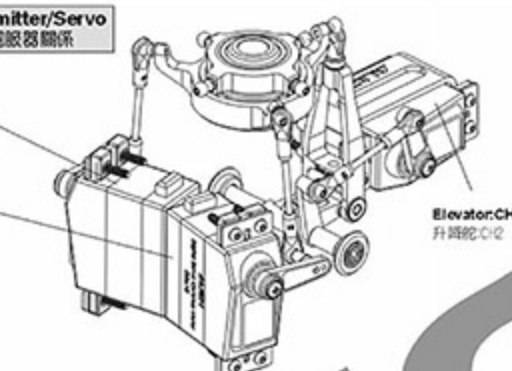

Elevator:CH2
升降舵:CH2

Positions of CH1 · CH6 are exchangeable, After assembling as photo (Note: Set the transmitter under CCPM 120 degrees mode), pull throttle stick (pitch) upward. If one swashplate servo (or two servos) moves downward, adjust reverse switch (REV) on the transmitter to make it moves upward. If three servo move downward, adjust the travel value (+) of SWASH CH6 on the transmitter to make them move upward. When the actions of Aileron and Elevator are opposite, adjust travel values of SWASH CH1 and CH2.

CH1 · CH6可互換位置，依圖安裝(注意：遙控器設定於CCPM 120°之設定模式，將副翼桿向上推，若單一螺距伺服器有向下移動，請調整接收器的反轉開關(REV)使副翼向上，若三個螺距伺服器均有向下移動，請調整接收器SWASH CH6行程量的正負值，使副翼與螺距向上移動，副翼與升降舵相反時，同樣調整 SWASH CH1 · CH2行程量正負值。

13.ADJUSTMENTS FOR GYRO AND TAIL NEUTRAL SETTING

陀螺儀與尾翼中立點設定調整

Recommend to choose Head Lock type for Gyro and turn off Revolution mixing(RVMX) mode on the transmitter, then set the gain switch on the transmitter and the gyro to Head lock mode. The gain setting is about 70%, and after transmitter setting, connect to BEC power to work on tail neutral setting. Note: When turn on BEC power, please do not touch tail rudder stick and the helicopter. Then wait for 3 seconds, make tail servo arm and tail servo at a right angle(90 degrees), tail pitch assembly must be correctly fixed about in the middle of the travel of tail rotor shaft for standard neutral setting.

陀螺儀選擇，建議選用鎖定向陀螺儀，其發射器內陀螺儀設定請關閉機軸混控模式，並將發射器上的感度開關與陀螺儀切至鎖定模式，感度設約 70% 左右，發射器設定完成後接上BEC接收電源，即可進行尾中立點設置。注意：當啓動BEC電源時請勿碰觸尾舵搖桿或碰觸機體，待3秒陀螺儀鎖定後尾舵桿與尾舵伺服器約成90°，尾旋翼控制組須正確置於尾橫軸行程約中間位置，即為標準尾中立點設定。

TAIL NEUTRAL SETTING 尾中立點設定

After setting Head Lock mode, correct setting position of tail servo and tail pitch assembly is as photo. If the tail pitch assembly is not at the neutral position, please adjust the length of rudder control rod to trim.

陀螺儀鎖定後尾舵桿與尾 Pitch控制組正確擺置位置，若尾 Pitch控制組未置中時請調整尾控制桿的長度來修正。

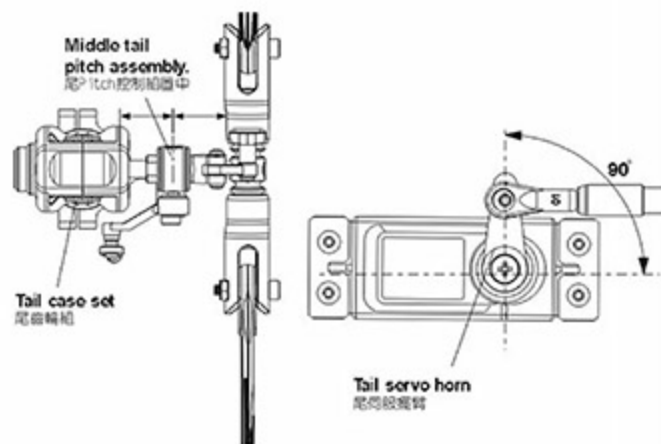

HEAD LOCK DIRECTION SETTING OF GYRO 陀螺儀鎖定向設定

To check the head lock direction of gyro is to move the tail counterclockwise and the tail servo horn will be trimmed clockwise. If it trims in the reverse direction, please switch the gyro to "REVERSE".

陀螺儀鎖定向確認，當手搖尾即逆時鐘擺動，尾舵桿將逆時鐘修正，反向時請切換陀螺儀上「鎖定反向」開關修正。



GENERAL FLIGHT 一般飛行模式

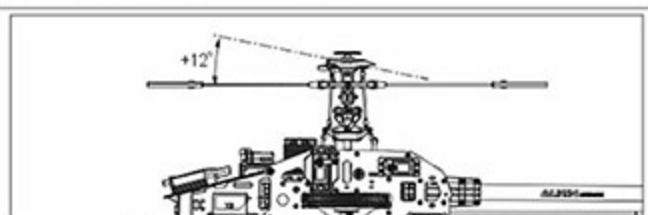

Stick position at high/Throttle 100%/Pitch +12°
搖桿高速/油門100%/Pitch+12°



Stick position at Hovering/Throttle 60%~65%/Pitch +5°
搖桿停懸/油門50%-65%/Pitch+5°

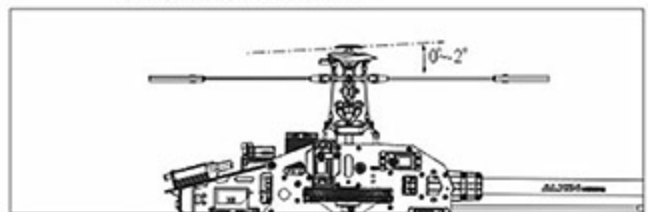

Stick position at low/Throttle 0%/Pitch 0~-2°
搖桿低速/油門0%/Pitch 0~-2°

GENERAL FLIGHT
一般飛行模式

Throttle 油門	Pitch 螺距
5 100% High speed 100% 高速	+12°
4 80%	
3 60%~65% Hovering 60%~65% 停懸	+5°
2 40%	
1 0% Low speed 0% 低速	0~-2°

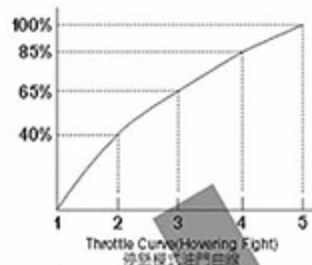

Pitch and Rotation Speed Pitch與轉速關係

TIP: It is recommended to use a lower pitch setting when using higher RPM Head speed. This will allow for better power.

搭配要領: 如果使用較高轉速馬達動力建議搭配調低 Pitch, 將獲得更佳動力效能。

3D FLIGHT 3D特技飛行模式

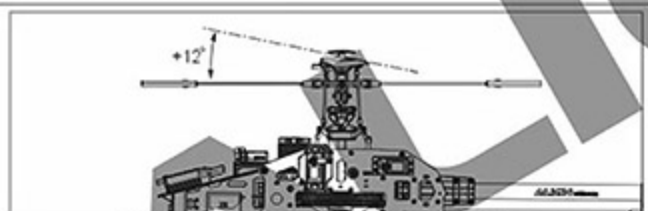

Stick position at high/Throttle 100%/Pitch +10~+12°
搖桿高速/油門100%/Pitch +10~+12°



Stick position at middle/Throttle 80%/Pitch 0°
搖桿中速/油門80%/Pitch 0°



Stick position at low/Throttle 100%/Pitch -12°
搖桿低速/油門100%/Pitch -12°

IDLE 1: SPORT FLIGHT

Throttle 油門	Pitch 螺距
5 100%	+10~+12°
4 75%	
3 70%	+5°
2 75%	
1 60%	-5°

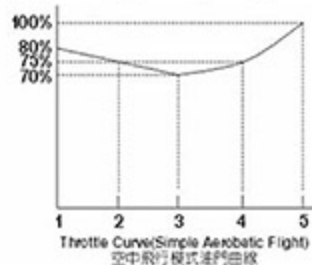

IDLE 2: 3D FLIGHT

Throttle 油門	Pitch 螺距
5 100% High 100% 高	+12°
3 60% Middle 60% 中	0°
3 100% Middle 100% 中	0°
1 100% Low 100% 低	-12°

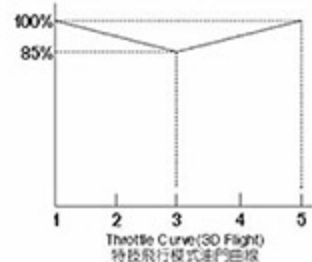

- Pitch range: Approx 26 degrees.
- If the pitch is set too high, it will result in shorter flight duration and poor motor performance.
- Setting the throttle to provide a higher speed is preferable to increasing the pitch too high.



注意

- 螺距 (Pitch) 總行程約 26°
- 過大螺距設定, 會導致動力與飛行時間降低。
- 動力提升以較高轉速的設定方式, 優於螺距調大的設定。

BATTERY 電池: ALIGN Li-Poly 44.4V 3300mAh

Motor Pinion Gear 馬達主齒	Main Rotor Blade 主旋翼規格	Pitch 螺距		Current(A) approx. 電流(A)大約值	Throttle Curve 油門曲線	RPM approx. 主旋翼轉速大約值
13T	600mm Carbon Fiber Blades 600碳纖維旋翼	Hover 停懸	+5°	13	0/50/65/85/100%	1750
		Idle	0°	19	85%Middle中	2500
			0°	23.6	100/100/100/100/100%	2720
			±12°	58		2470

NOTE: Please use a pitch gauge to adjust the pitch value. Incorrect excess pitch setting will result poor helicopter performance and reduce ESC's life and battery's life.

註：請務必使用螺距規來測量調整螺距，不正確的過大螺距設定不但無法發揮直升機的特性，反會影響到無刷調速器與電池的壽命。

RCM-BL600MX 510KV MOTOR RCM-BL600MX 510KV 無刷馬達

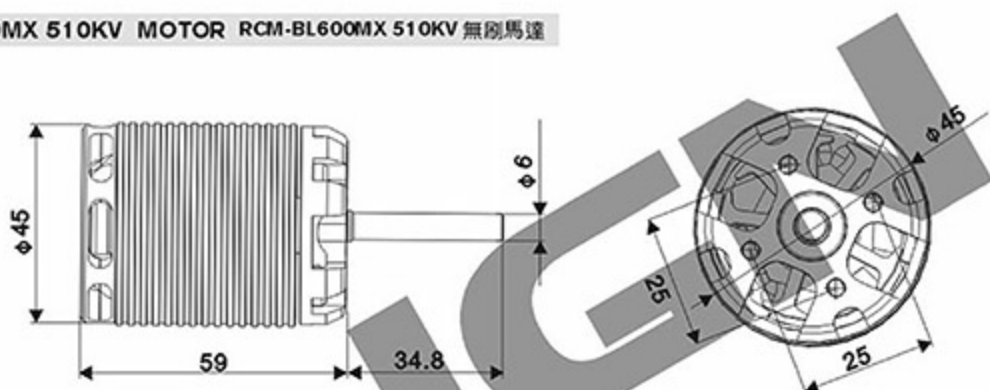

Specification 尺寸規格

KV	KV值	510KV(RPM/V)	Input voltage	輸入電壓	DC 11.1~50.4V
Stator Arms	矽鋼片槽數	12	Magnet Poles	磁鐵極數	10
Max continuous current	最大持續電流	75A	Max instantaneous current	最大瞬間電流	125A(5sec)
Max continuous power	最大持續功率	3300W	Max instantaneous power	最大瞬間功率	5500W(5sec)
Dimension	尺寸	Shaft 6x45x59mm	Weight	重量	Approx. 340g

Illustration 接線示意圖

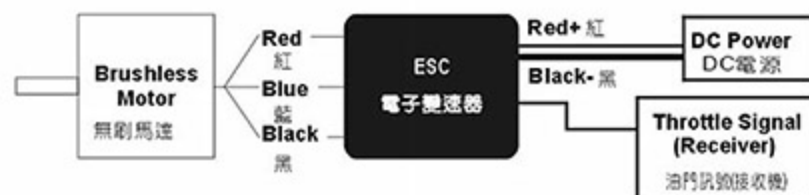

The motor rotates in different direction with different brand ESCs. If the wrong rotating direction happens, please switch any two cables to make the motor rotates in right direction.

由於各品牌電子變速器的馬達啟動轉向不盡相同，若發生轉向錯誤時，請將馬達與電子變速器的接線任兩條對調即可。

- Input voltage: DC 7.4V 2cell Lithium battery
- Output voltage: DC 5.8V
- Max. Continuous Current: 6A
- Integrated power switch and voltage indicator meter
- Utilizes a linear design, resulting in no interference to the receiver.
- Including a 5A 5.1V two-way step-down Voltage Regulator
- Size: 60x34x15mm
- Weight: 31g (including wire set)

- 輸入電壓: DC 7.4V 2CELL 鋰電
- 輸出電壓: DC 5.8V
- 最大連續輸出電流: 6安培
- 具電源切換開關與電壓指示燈功能
- 採線性設計, 無干擾接收機的缺點
- 附 5A 5.1V 雙向降壓器
- 尺寸: 60x34x15mm
- 重量: 31g (含線組)

WIRING ILLUSTRATION:

Connect a 5.1V two-way step-down voltage regulator between the gyro and the rudder servo.

接線示意圖:

5.1V 雙向降壓器連接於陀螺儀與尾舵伺服器之間。

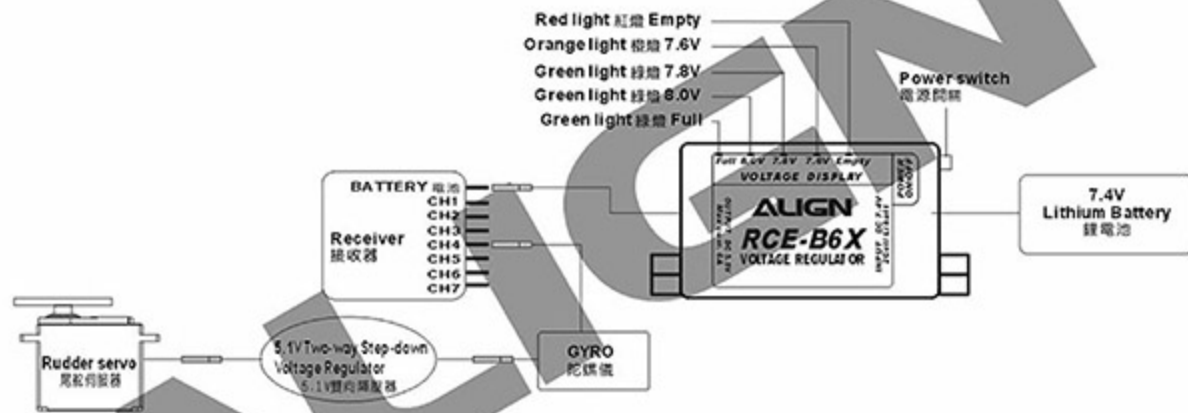

1. Auto-detecting voltage meter display lights. If the entire five-light array is illuminated, the battery is fully charged. When the voltage drops below 7.6V, the three green lights will be turned off. Use caution, the battery can only be safely used for a single flight. When only the red light is on, the battery voltage is drained, and must be fully recharged before use. Do not attempt to operate the model during this condition!
2. Some servos such as Futaba servo models 9241, 9251, 9253, 9254, 9255, 9256 and other digital servos are not capable of handling 6V. Please connect a 5.1V two-way step-down voltage regulator to avoid the servo damaged. If you are using a servo that can accept 6V input, the regulator is not required.
3. When using a speed controller with BEC output, you must remove the red wire of BEC output on the speed controller.
4. If the receiver does not have enough channels or an available socket, you can use a Y-type servo harness to share any channel with an existing connection.

1. 本產品具電壓指示功能。當插入充飽的電池時五顆指示燈全亮。表示電池在 Full 電量充足狀態下; 使用中當電壓降至 7.6V 時 (3 顆綠燈熄滅), 尚可完成單趟飛行即須對電池充電。成更換新電池; 而如果僅亮紅燈時表示 Empty 電量不足, 不應該再使用囉!
2. 部份的伺服器如: Futaba 9241, 9251, 9253, 9254, 9255, 9256 等, 此類型的伺服器不適合於較高的電壓下操作, 所以使用此類型的伺服器時請另外加裝 5.1V 降壓器, 避免伺服器損壞; 規格標示電壓 6V 輸入的伺服器則不須使用降壓器。
3. 使用與 BEC 輸出之速度控制器時, 必須將速度器 BEC 輸出的紅色線拆除!
4. 若接收機已無多餘的電源插孔時, 可利用一條伺服 Y 型連接線, 接到接收機的任一通道, 再將外接 BEC 與線下的通道一併接在 Y 型線上。

NOTE: When fixing the wire, please do not over tighten to avoid the connector come off or the wire broken when the helicopter rotates (vibration); do not operate in rain or moisture environment to avoid the electric parts short circuit and damaged.

注意: 固定線組時勿將各線組鎖緊, 以免轉機運轉時因震動造成接頭鬆脫或斷線; 避免在雨中或潮濕的環境下使用, 以免造成零件短路而損壞。

Features 產品特色

- Utilizes Silicon Micro Machines (S.M.M) sensor with excellent stability to dramatically reduce in-flight tail drifts.
- Utilizes AHTCS (Active Helicopter Tail Control System) to compensate any drift caused by wind direction and force, as well as unintended yaw induced by helicopter itself during flight maneuvers.
- Tailor made specifically for use with high speed digital rudder servos. This gyro features high sensitivity and minimal reaction time, fully utilizing the potential of modern high speed digital rudder servos.
- Suitable for all sizes of helicopters, from micro indoor to large 90 size glow helicopters.
- Metallic dampening plate built into bottom gyro casing, dramatically increasing anti-vibration and anti-interference abilities.
- Features 1520 μ s pulse wide and 760 μ s narrow pulse wide frame rate.
- Digital/Analog servo switchable.
- Reverse switch.
- Rudder servo travel limit adjustment (ATV).
- Mode switch for large/mini helicopter.
- Delay adjustment.
- Gyro locking mode and gain can be adjusted remotely from the transmitter.

- 採用 S.M.M 微細加工技術感測器, 具有極佳的穩定性, 大幅降低尾舵的偏移的機會。
- 採用 AHTCS (Active Helicopter Tail Control System) 主動式尾舵控制系統與尾舵控制系統, 主動修正因風向、風力變化與直昇機不同飛行姿態所產生之偏移。
- 專為高速型數位伺服器量身打造, 具有高靈敏度與極短的反應時間, 完全發揮伺服器高速反應的穩定能力。
- 適用於從室內電直至大型 90 直直。
- 下蓋與金屬防震片一體成型, 大幅提升抗震防干擾能力。

- 相容標準 1520 μ s 與窄頻 760 μ s 伺服器。
- 數位/類比伺服器切換。
- 尾舵正反方向控制切換。
- LIMI T 尾舵行程量設定。
- 大/小型直昇機模式切換。
- DELAY 控制延遲量設定。
- 可由遙控器控制鎖定與非鎖定模式, 以及調整陀螺儀感度。

Setting type 設定項目	1520/760 μ s	DS/AS	NOR / REV	LIMIT	Helicopter mode / DELAY 直昇機模式/DELAY
*STATUS*green "STATUS"綠燈	▲Standard 1520 μ s Servo ▲標準1520 μ s伺服器	▲Digital servo ▲DS數位伺服器	▲Normal rotation ▲NOR正轉	Left(Right)Travel limit 左(右)行程量	Medium/ large heli, suitable for T-REX 500/600/700 中型/大型直昇機 適用T-REX 500/600/700
*STATUS*red "STATUS"紅燈	Narrow band 760 μ s Servo 窄頻/760 μ s伺服器	Analog Servo AS類比伺服器	Reverse rotation REV反轉	Right(Left)Travel limit 右(左)行程量	Mini/ Micro heli, suitable for T-REX250/450 小型/迷你直昇機 適用T-REX 250/450
Setting instruction 設定方式說明	See no. 2 in setting instructions 參照設定方式第2項	See no. 3 in setting instructions 參照設定方式第3項	See no. 5 in setting instructions 參照設定方式第5項	See no. 6 in setting instructions 參照設定方式第6項	See no. 8 in setting instructions 參照設定方式第8項

NOTE: 1. *▲*Default setting * 2. Wrong heli mode will affect the performance of gyro. Do not fly before the complete setting.
註: 1. *▲*表示出廠設定值 * 2. 錯誤的直昇機模式將影響陀螺儀性能, 未完成設定前請勿飛行。

T-REX600/700 Standard setting T-REX600/700 標準設定



Diagram 各部名稱

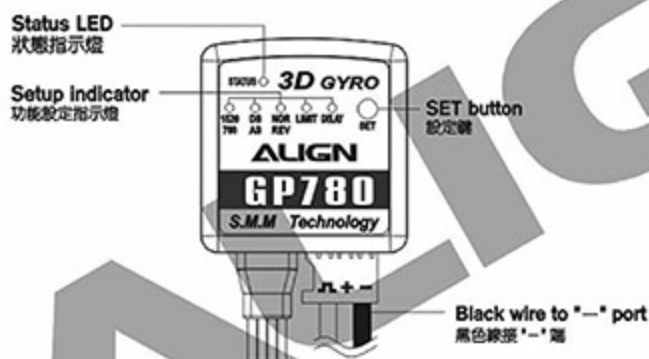

GP780 Gyro Specifications GP780陀螺儀產品規格

- Operating Voltage: DC 4.5~7V
- Current Consumption: <80mA @ 4.8V
- Angular Detection Speed: ± 500 degrees/sec
- Operating Temperature: $-20^{\circ}\text{C} \sim 65^{\circ}\text{C}$
- Operating Humidity: 0%~95%
- Size: 26x25x11mm
- Weight: 14g
- RoHS compliant
- 適用電壓: DC 4.5-7V
- 消耗電流: <80mA @ 4.8V
- 檢測角速度 ± 500 度/秒
- 操作溫度: $-20^{\circ}\text{C} \sim 65^{\circ}\text{C}$
- 操作濕度: 0%~95%
- 尺寸: 26x25x11mm
- 重量: 14g
- 符合RoHS環保規範

DS 650 Digital Servo DS 650數位伺服器

- Speed: 0.058sec / 60 degrees (4.8V)
0.048sec / 60 degrees (6.0V)
- Torque: 4.0kg.cm (4.8V)
5.0kg.cm (6.0V)
- Dimension: 40.3 x 20.1 x 36mm
- Weight: 56g (Servo horn not included)
- 1520 μ s (standard band)
- 動作速度: 0.058sec/60° (4.8V)
0.048sec/60° (6.0V)
- 輸出扭力: 4.0kg.cm (4.8V)
5.0kg.cm (6.0V)
- 尺寸: 40.3x20.1x36mm
- 重量: 56g(不含的角片)
- 1520 μ s(寬頻系統)



Illustration 接線示意圖

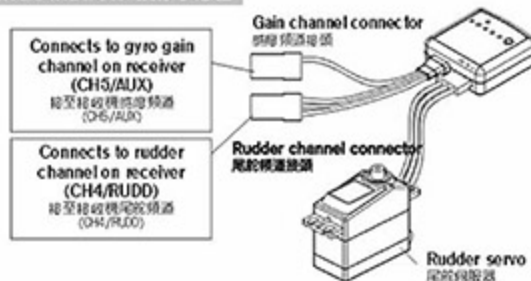

Gain and Rudder channel mapping diagram 連接對照表:

Transmitter type 遙控器種類	Rudder channel on Receiver 舵機頻道接線至接收器	Gain channel on Receiver 感度頻道接線至接收器
JR PPM/SPCM	"RUDD"	"AUX 2" or "AUX 3"
Hitec - Futaba PPM/PCM	"CH4" (RUD)	"CH5"
JR ZPCM	"RUDD"	"AUX 2"

Gyro Installation 陀螺儀的安裝

- Utilizing the included double sided foam tape as shown in diagram beside, mount the gyro on a solid platform or designated gyro mounting location on the helicopter. Ensure gyro mounting area have proper ventilation and away from heat sources.
- To avoid drift induced by erroneous yaw detection, the bottom surface of gyro must be perpendicular (90 degrees) relative to the main shaft.
- For installation on electric powered helicopters, the gyro should be installed as far away from the electronic speed controller (ESC) as possible to avoid interference (minimum 5cm).

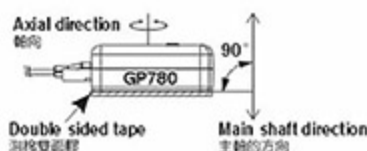

- 利用所提供的泡棉雙面膠如右圖所示，把陀螺儀固定在穩定的平台或機體預留的陀螺儀座，並確保它在通風良好的區域，遠離熱源。
- 陀螺儀底部水平貼附與直昇機的主軸呈垂直90度，否則會影響感知器對角度變化的偵測，造成偏移。
- 安裝於電動直昇機時盡量遠離(5公分以上)馬達與電子調速器，避免干擾情形發生。

Usage Setting Instructions 使用及設定方式

- Transmitter Settings:** After powering up transmitter, make sure rudder subtrim is zeroed. Then power on the receiver and gyro. The gyro will go through initializing process indicated by flashing LED from left to right. Do not touch the heli or transmitter sticks until initializing is complete, as indicated by a steady IR LED. A green LED indicates gyro is in AHTCS locking mode, while red LED indicates gyro is in normal mode.
- Note:** The GP780 is set to 1520 μ s at the factory. If 760 μ s servo is used in 1520 μ s mode, rudder servo will deflect to the side and unable to center. For more critically, the linkage rod may jam and cause the servo burned out. Please follow the instruction (Usage setting 2) to change the setting if 760 μ s servo is used. Please ensure the following mixing functions (if available) are disabled or zeroed on the transmitter.

- ATS
- Pilot authority mixing
- Throttle to rudder mixing
- Rudder to gyro mixing
- Pitch to rudder mixing
- Revolution mixing

- 1520 μ s (standard) or 760 μ s (narrow band) servo selection: GP780 offers compatibility for two types of frame rates under digital mode. Please set the GP780 to 760 mode if 760 μ s frame rate rudder servos (such as Futaba S9256, S9251, BLS251) are used. Most other servos have 1520 μ s frame rate, and GP780 should be set to 1520 mode if those servos are used. To enter the setup mode: Press and hold the SET button for 2 seconds, and the STATUS LED will begin flashing. When the 1520/760 indicator lit up, you are in the servo frame rate setup menu. Use the rudder stick on your transmitter to select the frame rate: move the stick to left (or right) and STATUS led changes to green, the frame rate has been set to 1520 μ s. If you want to set the frame rate to 760 μ s, move the stick to opposite end 3 times to make STATUS led changes to red. (Note: The faceplate of GP780 has the setting values listed in the corresponding green/red letters.) Press the SET to confirm the current setting and enter the next setting. The GP780 will exit setting mode if left idle for 10 seconds.

- Digital (DS) / Analog (AS) Servo Selection: Servo speed is of paramount importance in maximizing the gyro's performance. Fast servos are able to respond to gyro commands quickly, resulting in the speed and precision of overall system. Due to the high sensitivity of GP780 gyro, high speed digital servos such as Align DS650, DS620, DS520, DS420, Futaba S9257, S9256, S9254, S9253, or other similar spec servos are recommended. Select "DS" when digital servos are used, and "AS" when analog servos are used.

- To enter the setup mode: Press and hold the SET button for 2 seconds, and the STATUS LED will begin flashing. Press the SET button repeatedly until DS/AS led is lit. Use the rudder stick on your transmitter to select the Servo type: move the stick to left (or right) and STATUS led changes to green, the servo type is set to DS. Move the stick to opposite direction and STATUS led changes to red, the servo type is set to AS.

- Warning:** The use of analog servo under "DS" mode will result in servo failure. The GP780 gyros are set to "DS" mode at the factory. Please set the proper servo type based on servo used.

- Check the direction of rudder: move the rudder stick on transmitter left/right and check the helicopter's instruction manual for correct rudder direction. Servo reverse function on the transmitter can be used for reversed rudder. Set the transmitter gyro gain channel to normal mode, or press and hold the SET button for 2 seconds to center the rudder servo. Adjust the servo horn so it is perpendicular (90 degrees) relative to the pushrod. Then adjust the rudder linkage length so the tail pitch control system is within range.

Setting Method: Press and hold the SET button for 2 seconds to enter the setup menu, and select DELAY setting. Push the rudder stick left or right and observe the STATUS LED. Red represents mini/micro helis, green represents medium/large helis.

The amount of delay is set by holding the rudder stick at the position corresponding the delay percentage, 0% at middle stick position and 100% at the end position, and pressing the SET button to confirm the delay setting.

- 檢查遙控器的設定：先關閉遙控器電源，將尾舵的感測器零位，再開啟直昇機的接收機電源，此時陀螺儀會先進入初始化狀態，所有指示燈會由左至右閃爍，接著使尾舵伺服器回到中立點，在此之前請勿動直昇機或機尾舵的搖桿，當狀態指示燈為綠色時表示陀螺儀在鎖定的狀態，指示燈為紅色時表示陀螺儀在非鎖定的狀態。

※註：GP780出廠時內建為 1520 μ s 系統，若使用 760 μ s 窄頻伺服器時，開機後尾舵伺服器將會偏向一邊無法居中，甚至造成連桿卡死而使伺服器燒毀，請參照使用及設定方式第2項更改設定值。

如果您的遙控器有下列功能時，請設定為關閉(OFF)或數值設定為零

- ATS
- Pilot authority mixing
- Throttle to rudder mixing
- Rudder to gyro mixing
- Pitch to rudder mixing
- Revolution mixing

- 1520 μ s (標準) 或 760 μ s (窄頻) 伺服器選擇：GP780 相容兩種波寬控制系統，若您使用的伺服器屬於 760 μ s 系統 (如 Futaba S9256、S9251、BLS251)，則必須將 GP780 設定於 760 的模式，其他未標示 760 μ s 規格之伺服器，一般皆為 1520 μ s 系統，必須將 GP780 設定為 1520 的模式。

如何進入功能設定模式：持續按壓機上的 SET 設定鍵約 2 秒，此時 STATUS 狀態指示燈會開始閃爍，且 "1520/760" 的功能設定指示燈會亮，表示進入標準/窄頻伺服器選項，利用遙控器方向舵搖桿的左右方向來選擇設定值，例如方向舵搖桿往左 (或右) 時，STATUS 指示燈為綠色，表示設定值為 1520 μ s 系統；若設定為窄頻 760 μ s 系統時，必須將搖桿由中立點往相反方向連續搖動 3 次，使 STATUS 指示燈亮紅色，才會進入 760 μ s 系統。(註：GP780 的面板上已使用綠/紅色的字體標示 STATUS 燈色所代表的設定值，設定完成後按 SET 鍵一次可進入下一級設定，或 10 秒內不進行任何設定，GP780 會自動離開設定模式。

- DS 數位 / AS 類比伺服器選擇：伺服器動作速度感測器性能，伺服器動作愈快，就能立即反應陀螺儀送出的指令，發揮快速精準的效能；由於 GP780 具有相當快速的反應時間與靈敏度，所以建議您搭配高速度數位伺服器，如 ALIGN DS650、DS620、DS520、DS420、Futaba S9257、S9256、S9254、S9253 或其他相同規格伺服器，以獲得最佳效能。設定方式：持續按 SET 鍵 2 秒進入功能設定模式，再按 SET 鍵選擇 DS/AS 選項。(DS/AS 指示燈亮綠)，利用方向舵搖桿選擇數位 (STATUS 為綠燈) 或類比 (STATUS 為紅燈) 伺服器。

注意：在 DS 模式下連接類比伺服器將會導致伺服器燒毀，本產品出廠時設定在 DS 模式，請自行依所搭配的伺服器類型選擇正確的模式。

- 檢查尾舵伺服器正逆轉方向與調整連桿：左右移動尾舵的搖桿，確認尾舵伺服器移動的方向是否正確，若不正請更改遙控器上的尾舵伺服器正逆轉方向，將 GP780 切換成非鎖定模式或持續按 GP780 的 SET 鍵 2 秒，使尾舵伺服器保持在中立點的位置上，調整伺服器片，儘可能使尾舵的連桿與伺服器呈 90 度，接著調整連桿長度使尾舵控制組在中立點。

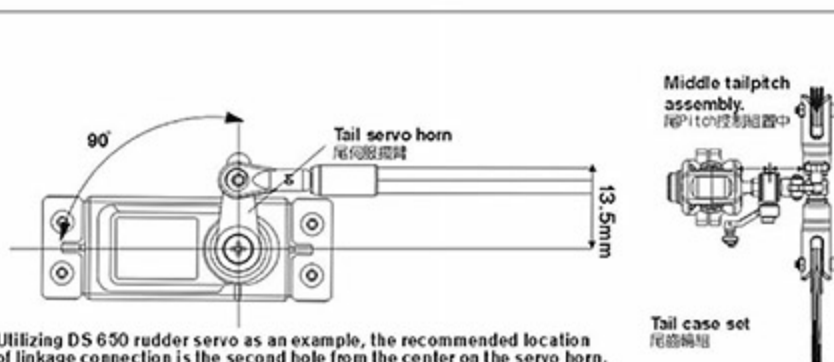

Utilizing DS 650 rudder servo as an example, the recommended location of linkage connection is the second hole from the center on the servo horn. The ideal distance from linkage connection to servo center is 13.5mm.

以 DS650 尾舵伺服器為例，建議將連桿鎖於伺服器片由內算起的第三孔，使尾舵控制組與伺服器平行距離 13.5mm 左右為最佳。

5. **Setting of gyro direction nor/rev.** Check the gyro direction by moving the heli on the yaw axis while holding by hand. Observe the direction gyro is moving the rudder servo. If direction is incorrect, switch the direction switch on the gyro to compensate.
 To enter the setup mode: Press and hold the SET button for 2 seconds, and the STATUS LED will begin flashing.
 Press the SET button repeatedly until NOR/REV led is lit. Use the rudder stick on your transmitter to select the Servo type: move the stick to left (or right) and STATUS led changes to green, the servo direction is set to NOR.
 Move the stick to opposite direction and STATUS led changes to red, the servo direction is set to REV.
 Warning: Flying with reversed gyro will cause the heli to spin out of control. Please double check the direction before attempting to fly the heli.
6. **Rudder Servo Travel Limit Adjustment:** Press and hold the SET button for 2 seconds until the STATUS LED flashes.
 At this point the rudder servo will be centered. Press the SET button repeatedly until LIMIT led is lit. While observing the heli tail, gradually move the rudder stick on your transmitter left until the tail pitch slider reaches its mechanical end/without binding), then center the rudder stick and wait 2 seconds until STATUS LED flashes red. Now perform the same for right rudder: move the rudder stick on your transmitter right until the tail pitch slider reaches the other end, center the stick and wait 2 seconds for LED to flash again. This will set the travel limit of the servo on both sides. Insufficient rudder servo travel limit will result in decreased rudder performance, while excessive rudder servo travel will overload the rudder servo and cause failures.
 Caution: Rudder travel setting can not be below 50%, or else GP780 will not register the settings. If excessive travel is observed even after performing the above rudder travel adjustments, please relocate the rudder servo linkage ball closer to the center of servo horn.
7. **Gyro Gain Adjustments:** For radio with GYRO function, gain can be adjusted using this function. The AHTCS (heading lock) gain is set by adjusting the GYRO setting between 50% to 100%, while the normal mode gain is set by adjusting the GYRO setting between 0 to 49%. Actual gain settings will differ amongst different heli and/or servo. The goal is to achieve as high of gain as possible without the tail oscillating (wagging), therefore such adjustment can only be done under actual flight conditions.
 Suggested initial settings are 70~80% during hover, and 60~70% during idle-up conditions. Gyro gain can be increased or decreased after observing the presence of tail oscillation during flights.
 Note: For radio systems using 0-100% as gain adjustment under heading lock mode (such as Futaba), the recommended gain setting is approximately 30~35%. For radio system using 50-100% as gain adjustment under heading lock mode (such as JR and Hitec), the recommended gain setting is approximately 70~75%.
8. **heli mode and delay setting.** These settings incorporates two functions:
 (1) GP780 supports mini/micro indoor helicopters. Set the setting based on the appropriate helicopter class.
 For example: Set the helicopter mode to mini/micro setting (STATUS LED turns red) for T-Rex 250 and 450; set the helicopter mode to medium/large setting (Status LED turns green) for T-Rex 500/600/700.
 (2) Slow rudder servos may cause tail oscillation as it receives the faster signal from gyro. If tail oscillation occurs after hard stop from stationary pirouette, increase the gain setting until such oscillation stops.
Setting Method: Press and hold the SET button for 2 seconds to enter the setup menu, and select DELAY setting. Push the rudder stick left or right and observe the STATUS LED. RED STATUS represents mini/micro heli such as T-REX250/450, GREEN STATUS represents medium/large heli such as T-REX500/600/700. The amount of delay is set by holding the rudder stick at the position corresponding the delay percentage, 0% at middle stick position (DELAY STATUS LED is flashing) and 100% at the end position, and pressing the SET button to confirm the delay setting.
5. NOR/REV: 陀螺正逆轉調整: 提起直升機, 將機頭往左擺動, 若尾槳伺服器的擺動方向與遙控器的方向的搖桿打右的方向一致, 表示陀螺的動作方向設定正確, 若不正時請更改正逆轉設定。設定方式: 持按"SET"鍵2秒進入功能設定模式, 選擇NOR/REV選項, 以方向搖桿選擇NOR (STATUS為綠燈) 或REV (STATUS為紅燈)。
 注意: 陀螺的正逆轉方向設定錯誤時會造成直升機高速自旋的危險, 請務必確認。
6. LIMIT: 尾槳行程限制調整: 持按"SET"鍵2秒進入功能設定模式, 此時尾槳伺服器會保持在中立點的位置上, 選擇LIMIT選項, 接著將方向搖桿慢慢的往左移動, 使尾槳到達該側的最大行程限度, 將搖桿回到中立點不動, 持2秒後"STATUS"指示燈會亮紅燈閃爍, 表示左側行程量已記憶; 接著將尾槳的搖桿往右移動至控制側最大行程限度, 再將搖桿回到中立點不動, 持2秒後"STATUS"指示燈會亮紅燈閃爍, 即完成左右行程量設定, 行程量不足時會影響陀螺儀與直升機的性能, 行程量過大易造成伺服器過熱。
 注意: 尾槳行程量設定不可低於50%, 否則GP780將不予記憶, 若發生行程量設定後, 尾槳制動仍會超過最大行程, 請將尾槳伺服器的行程向內移動, 避免行程量不足影響陀螺儀性能。
7. 感應調整: 一般具有陀螺儀感應設定功能的遙控器, 可直接進入GYRO功能選項進行感應值的設定, 設定值50%則陀螺儀的感應為0, 設定值50%~100%, 則陀螺儀感應值為設定狀態的50~100%; 設定值50%~0%, 則陀螺儀感應值為非設定狀態的50~100%, 感應值的大小會隨著陀螺儀與直升機的不同而有所差異, 一般而言, 在不產生尾槳現象(直昇機尾槳出現左右搖擺的情況)的前提下感應值愈高愈好, 所以只能透過實際飛行的狀況來進行調整。
 進入遙控器感應值的選項, 剛開始時建議先設定在70~80%左右, idle up飛行時設定在60~70%左右, 之後再依實際飛行的狀態再行修正, 如果沒有搖擺現象發生時可再調整高感應, 若發生尾槳現象時, 則降低感應。
 ※註: 設定感應值為0~100%的遙控器, 如Futaba, 建議設定在30~35%左右; 設定感應值為50~100%的遙控器, 如JR、HITEC, 建議感應值設定在70~75%左右。
8. 直升機模式與DELAY控制延遲量調整, 此設定結合兩項功能:
 (1) GP780支援小型/迷你型室內直升機, 請依直升機的模式選擇適合的模式, 如: T-REX 250/450請選擇小型/迷你型模式(設定時"STATUS"指示燈為紅燈); T-REX500/600/700請選擇大型直升機模式(設定時"STATUS"指示燈為綠燈)
 (2) 使用速度較慢的尾槳伺服器較容易產生尾槳現象, 當直升機停機時, 打方向桿使直升機快速自轉, 當方向桿回到中立點使直升機停止自轉時, 此時若發生尾槳現象, 請增加控制延遲的設定量, 一般而言在不產生尾槳現象的前提下控制延遲的設定愈高愈好, 否則尾槳的動作會變得很遲。
 設定方式: 持按"SET"鍵2秒進入功能設定模式, 選擇DELAY選項, 以方向搖桿選擇小型/迷你型或大型直升機如T-REX 250/450 (STATUS為紅燈), 或中大型直升機如T-REX500/600/700 (STATUS為綠燈), 若需同時設定DELAY控制量時, 則利用方向搖桿的位置來設定, 搖桿由中立點推至"DELAY"燈閃爍時為0%, 推至最大行程時控制量為100%, 將搖桿推至所需的延遲量時保持不動, 並按下"SET"鍵確認, 即可同時設定直升機模式與延遲量。

18. FLIGHT ADJUSTMENT AND SETTING 飛行動作調整與設定

ALIGN

PLEASE PRACTICE SIMULATION FLIGHT BEFORE REAL FLYING 飛行前請先熟練模擬飛行

Do a simulation flight until you familiarize your fingers with the movements of the rudders, and keep practicing until the fingers move naturally.

- Place the helicopter in a clear open field (Make sure the power OFF) and the tail of helicopter point to yourself.
- Practice to operate the throttle stick (as below illustration) and repeat practicing "Throttle high/low", "Aileron left/right", "Rudder left/right", and "Elevator up/down".
- The simulation flight practice is very important, please keep practicing until the fingers move naturally when you hear operation orders being called out.
- Another safe and effective practice method is to use the transmitter flying on the computer through simulator software sold on the market.

在還沒瞭解直升機各動作的操作方式前, 嚴禁通電飛行, 請先進行模擬飛行的練習, 並不斷的重複, 直到手指可熟練的控制各個動作及方向。

- 將直升機放在空曠的地方(確認電源為關閉), 並將直升機的機尾對準自己。
- 練習操作遙控器的各搖桿(各動作的操作方式如下圖), 並反覆練習油門高/低、副翼左/右、升降槳前/後及方向左/右操作方式。
- 模擬飛行的練習相當重要, 請重複練習直到不覺思慮, 手指能自然隨著喊出的指令移動控制。
- 另一種最有效、最安全的練習方式, 就是透過市面販售的模擬軟體, 以遙控器在電腦上模擬飛行, 熟悉各種方向的操控。



Mode 1	Mode 2	Illustration 圖示
 Aileron 副翼		
 Elevator 升降槳後		
 Throttle 油門		
 Rudder 方向		

FLIGHT ADJUSTMENT AND NOTICE FOR BEGINNERS 初學飛行調整與注意



- ⊙ Check if the screws are firmly tightened.
- ⊙ Check if the transmitter and receivers are fully charged.
- ⊙ 再次確認螺絲是否鎖緊?
- ⊙ 發射器和接收器電池是否足電?



If there are other radio control aircraft at the field, make sure to check their frequencies and tell them what frequency you are using. Frequency interference can cause your model, or other models to crash and increase the risk of danger. 假使飛行場有其他遙控飛機，請確認他們的頻率，並告知他們你正在使用的頻率。相同的頻率會造成干擾導致失控和大大地增加風險。

★ When arriving at the flying field.

★ 當抵達飛行場



STARTING AND STOPPING THE MOTOR 啟動和停止馬達

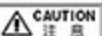

First check to make sure no one else is operating on the same frequency. Then place the throttle stick at lowest position and turn on the transmitter. 首先確認附近沒有其他相同頻率的機，然後打開發射器將油门桿推到底點。

★ Check the movement.

★ 動作確認



ON! Step1
First turn on the transmitter.
先開發射器



ON! Step2
Next turn on BEC of the receiver.
再開接收器BEC電源

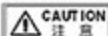

Check if the throttle stick is set at the lowest position. 確認油门桿桿在最低的位置。

Mode 1 Mode 2

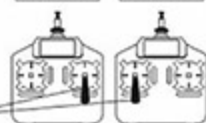

- ⊙ Are the rudders moving according to the controls?
- ⊙ Follow the transmitter's instruction manual to do a range test.
- ⊙ 方向舵是否隨著控制桿向移動?
- ⊙ 根據發射器說明書進行距離測試。



ON! Step3
Connect to the power
接上主動力電源



OFF! Step4
Reverse the above orders to turn off.
關閉電源時請按上述操作動作反執行。

Main rotor adjustments 主旋翼平衡調整



Tracking adjustment is very dangerous, so please keep away from the helicopter at a distance of at least 10m. 調整軌跡非常危險，請於距離飛機最少10公尺的距離。

1. Before adjusting, apply a red piece of tape on one blade, or paint a red stripe with a marker or paint to identify on blade.
2. Raise the throttle stick slowly and stop just before the helicopter lifts-off ground. Look at the spinning blades from the side of the helicopter.
3. Look at the path of the rotor carefully. If the two blades rotate in the same path, it does not need to adjustment. If one blade is higher or lower than the other blade, adjust the tracking immediately.
4. Linkage rod (A): Regular pitch trim (For large variations). Linkage rod (C): Slight pitch trim (For slight variations).

1. 調整前先在其中一支旋翼的翼端，貼上有紅色的貼紙或畫上紅色記號，方便觀察調整位置。
2. 慢慢的推起油门桿到起飛前，從飛機側面觀察旋轉的主旋翼。
3. 仔細觀察旋翼軌跡(假如兩支旋翼移動都是相同的軌跡，則不需要調整;可是如果一支旋翼較高或較低產生“雙槳”的情形時，則必須立刻調整軌跡)。
4. 選擇(A)為一般調整(雙槳大時使用)，選擇(C)為微調整(雙槳微偏差時使用)。

- A. When rotating, the blade with higher path means the pitch too big, Please shorten pitch linkage rod (C) for slight trim.
B. When rotating, the blade with lower path means the pitch too small, Please lengthen pitch linkage rod (C) for slight trim.



Incorrect tracking may cause vibrations. Please repeat adjusting the tracking to make sure the rotor is correctly aligned. After tracking adjustment, please check the pitch angle is approx +4~5° when hovering. 不正確的旋翼軌跡會導致震動，請不斷重複調整軌跡，從旋翼軌跡精準正確。在調整軌跡後，確認一下Pitch角在停機時應為大約+4~5°。



FLIGHT ADJUSTMENT AND NOTICE FOR BEGINNERS 初學飛行調整與注意

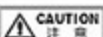

- ⊙ Make sure that no one or obstructions in the vicinity.
- ⊙ You must first practice hovering for flying safety. This is a basic flight action. (Hovering means keeping the helicopter in mid air in a fixed position)
- ⊙ 確認附近地區沒有人和障礙物。
- ⊙ 為了飛行安全，你必須先練習停機，這是飛行動作的基本(停機:直昇機停機空中並保持固定位置)。

- ⊙ Please stand approximately 10m diagonally behind the helicopter.
- ⊙ 練習時，請站在直昇機後方10公尺。

Beginner may install a training landing gear to avoid any crash caused by off set effect while landing. 必要時初學者可以在腳架下方安裝練習腳架，可避免降落時因重心偏移導致主旋翼或直昇機損毀。



STEP 1 THROTTLE CONTROL PRACTICE 油门控制練習

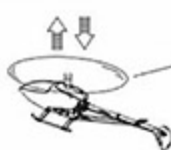
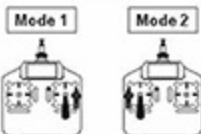

- ⊙ When the helicopter begins to lift-off the ground, slowly reduce the throttle to bring the helicopter back down. Keep practicing this action until you control the throttle smoothly.
- ⊙ 當直昇機開始離地時，慢慢降低油门桿將飛機降下。持續練習飛機從地面上升和下降直到你覺得油门控制很順。

STEP 2 AILERON AND ELEVATOR CONTROL PRACTICE 副翼和升降控制練習

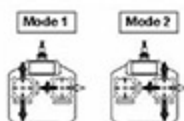

1. Raise the throttle stick slowly.
 2. Move the helicopter in any direction back, forward, left and right, slowly move the aileron and elevator sticks in the opposite direction to fly back to its original position.
1. 慢慢升起油門搖桿。
2. 使直昇機依順序：移動向後/向前/向左/向右，慢慢的反向移動副翼和升降搖桿並將直昇機回到原來位置。

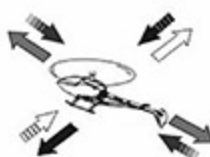

- ⚠ **CAUTION 注意**
- ⊙ If the nose of the helicopter moves, please lower the throttle stick and land the helicopter. Then move your position diagonally behind the helicopter 10m and continue practicing.
 - ⊙ If the helicopter flies too far away from you, please land the helicopter and move your position behind 10m and continue practicing.
 - ⊙ 當直昇機機頭偏移時，請降低油門並且降落，然後移動自己的位置到直昇機的正後方10公尺再繼續練習。
 - ⊙ 假如直昇機飛離你太遠，請先降落直昇機，並到直昇機後10公尺再繼續練習。

STEP 3 RUDDER CONTROL PRACTICING 方向舵操作練習

1. Slowly raise the throttle stick.
 2. Move the nose of the helicopter to right or left, and then slowly move the rudder stick in the opposite direction to fly back to its original position.
1. 慢慢升起油門搖桿。
2. 將直昇機機頭移動在左右，然後慢慢反向移動方向舵搖桿並將直昇機飛回原本位置。



STEP 4

After you are familiar with all actions from Step1 to 3, draw a circle on the ground and practice within the circle to increase your accuracy.

當你覺得 Step1-3 動作熟悉了，在地上畫個圓並在這個圓的範圍內練習飛行，以增加你操控的準確度。

⊙ You can draw a smaller circle when you get more familiar with the actions.

⊙ 當你更加習慣操作動作，你可以畫更小的圓圈。



STEP 5 DIRECTION CHANGE AND HOVERING PRACTICE 改變直昇機方向和懸浮練習

After you are familiar with Step1 to 4, stand at side of the helicopter and continue practicing Step1 to 4.

Then repeat the Step1 to 4 by standing right in front of the helicopter.

當你覺得 Step1-4 動作熟悉了，站在直昇機側面並繼續練習 Step1-4，之後，站在直昇機機頭右邊重複步驟練習。



ADJUSTMENT OF EACH TRIM 飛行動作微調

Slowly raise the throttle stick and just as the helicopter lift-off the ground, you can use the trim to correct the action if the helicopter leans in a different direction.

慢慢升起油門搖桿，當直昇機飛離地面時，若直昇機傾向不同方向，可使用微調修正動作。

1. Adjustment of elevator trim 調整升降舵微調
Just before the helicopter lift-off, the nose lean forward/backward...

When leans forward, adjust the trim down.

When leans backward, adjust the trim up.

在直昇機正要起飛時，機頭向前/後方向偏移...

向前偏移時，微調向下調整。

向後偏移時，微調向上調整。

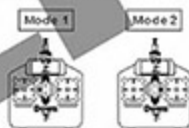

2. Adjustment of Aileron trim 調整副翼微調
Just before the helicopter lift-off, the body lean left/right...

When leans right, adjust the trim to left side.

When leans left, adjust the trim to right side.

在直昇機正要起飛時，機身向左/右方向偏移...

向左偏移時，微調向左調整。

向右偏移時，微調向右調整。

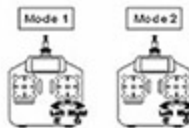

TROUBLE SHOOTING DURING FLIGHT 如何排除飛行中的狀況

	Situation 狀況	Cause 原因	Way to deal 對策
Blade Tracking 雙槳平衡	Out of tracking 雙槳	★ Adjustment of pitch rod has not been done. ★ PITCH 連桿長度調整不平均	★ Adjust the length of linkage rod(C) ★ 調整連桿(C)長度
During Hovering 停旋	Low rotation of the rotor 主旋翼轉速偏低	★ Pitch of main blade is high. ★ 主旋翼的 PITCH 偏高 ★ Throttle curve is too low during hovering. ★ 停旋點油門曲線過低	★ Lower the pitch about 4~5° during hovering. (The rotation should be about 1,750rpm during hovering). ★ 調低 Pitch 停旋 Pitch 約 4~5° 停旋時主旋翼轉速約 1750rpm ★ Heighten the throttle curve during hovering.
	High rotation of the rotor 主旋翼轉速偏高	★ Pitch of main blade is low. ★ 主旋翼的 PITCH 偏低 ★ Throttle curve is too high during hovering. ★ 停旋點油門曲線過高	★ Adjust the pitch rod(A). (The rotation should be about 1,750rpm during hovering). ★ 調整連桿(A) (停旋時主旋翼轉速約 1750rpm) ★ Lower the throttle curve during hovering. ★ 調低停旋點油門曲線
Sensitivity of the gyro 陀螺儀敏感度	The tail leans to one side during hovering, or when trim the rudder and return to the neutral, the tail lags and cannot stay in a control position. 停旋時尾翼向某一邊偏移，或撥動方向舵並回到中立點時，尾翼產生延遲，無法停穩在所控制位置上。	★ Failure setting of tail neutral point. ★ 尾中立點設定不當 ★ The sensitivity of the gyro is low. ★ 陀螺儀敏感度偏低	★ Reset tail neutral point. ★ 重設尾中立點 ★ Increase the sensitivity. ★ 增加敏感度
	The tail wags left and right during flight at hovering or full speed. 停旋或全速時尾翼左右來回搖擺。	★ The sensitivity of the gyro is high. ★ 陀螺儀敏感度偏高	★ Decrease the sensitivity. ★ 降低敏感度

※ If the problem is still there even after tried above, stop flying and contact with your seller.

※ 在做完以上調整後，仍然無法改善情況時，應立即停止飛行並連絡您的經銷商。

ALIGN

Specifications & Equipment/規格配備:

Length/機身長:1160mm

Height/機身高:353mm

Main Blade Length/主旋翼長:600mm

Main Rotor Diameter/主旋翼直徑:1347mm

Tail Rotor Diameter/尾旋翼直徑:260mm

Motor Pinion Gear/馬達齒輪:13T

Main Drive Gear/傳動主齒輪:112T

Autorotation Tail Drive Gear/尾驅動主齒:131T

Tail Drive Gear/尾翼傳動齒:34T

Drive Gear Ratio/齒輪傳動比:8.61:1:3.85

Weight(With Motor)/空機重(含馬達):2350g

