

ALIGN INSTRUCTION MANUAL

GP780 Head Lock Gyro
& DS620 Digital Servo

S.M.M Technology



Thank you for purchasing the GP780 Gyro. Please read the manual carefully before installing and be sure to retain the manual for future reference.

GP780 is set to 1520 μ s and under DS digital servo mode at the factory. Please make sure your servo type before install the GP780 to avoid any damage due to improper setting. Please read the setting instructions for the setting modification.

The Meaning Of Symbols

	Mishandling due to failure to follow these instructions may result in damage or injury.
	Mishandling due to failure to follow these instructions may result in danger.

- Please stop using when anything unusual happens and consult to your seller or experienced pilot.
- Be sure not to store the gyro near any source of heat .
- Please keep the gyro away from moisture or exposure to water.
- Check the gyro everytime after uses to ensure there is nothing damaged.
- If the gyro dropped or get hit, please do not use the gyro and consult to your seller or experienced pilot.

Features

- Utilizes Silicon Micro Machines (S.M.M) sensor with excellent stability to dramatically reduce in-flight tail drifts.
- Utilizes AHTCS (Active Helicopter Tail Control System) to compensate any drift caused by wind direction and force, as well as unintended yaw induced by helicopter itself during flight maneuvers.
- Tailor made specifically for use with high speed digital rudder servos. This gyro features high sensitivity and minimal reaction time, fully utilizing the potential of modern high speed digital rudder servos.
- Suitable for all sizes of helicopters, from micro indoor to large 90 size glow helicopters.
- Metallic dampening plate built into bottom gyro casing, dramatically increasing anti-vibration and anti-interference abilities.
- Features 1520 μ s pulse wide and 760 μ s narrow pulse wide frame rate.
- Digital/Analog servo switchable.
- Reverse switch.
- Rudder servo travel limit adjustment (ATV).
- Mode switch for large/mini helicopter.
- Delay adjustment.
- Gyro locking mode and gain can be adjusted remotely from the transmitter.

Program Setting Table

Setting type	1520/760 μ s	DS/AS	NOR/REV	LIMIT	Helicopter mode / DELAY
"STATUS"green	▲Standard 1520 μ s Servo	▲Digital servo	▲Normal rotation	Left(Right)Travel limit	Medium/ large heli, suitable for T-REX500/600/700
"STATUS"red	Narrow band 760 μ s Servo	Analog Servo	Reverse rotation	Right(Left)Travel limit	Mini/ Micro heli, suitable for T-REX250/450
Setting instruction	See no. 2 in setting instructions	See no. 3 in setting instructions	See no. 5 in setting instructions	See no. 6 in setting instructions	See no. 8 in setting instructions



1. "▲" Default setting.

2. Wrong heli mode will affect the performance of gyro. Do not fly before the complete setting.

T-REX 500/600/700 Setting Instructions

Green: 1520 μ s standard band

Standard/Narrow band setting

Green: Digital Servo

DS/AS Setting

Green: Normal rotation.
Red: Reverse rotation.

Servo NOR/REV Setting

The STATUS LED color does not indicate any setting here

Travel Limit Setting

Green: Suitable for T-REX 500/600/700 or other medium to large helicopters

Helicopter mode/DELAY Setting

Move the transmitter rudder stick to the needed delay percentage and press the "SET" button.

The GP780 is set to 1520 μ s at the factory. Use the rudder stick on your transmitter to select, and set it to green STATUS LED.

When using Align DS series digital servos, please set it to green STATUS LED.

Move the heli and observe if the direction of tail rotor compensation is correct. If not, please modify the NOR/REV Setting.

Gradually move the rudder stick on your transmitter left until the tail pitch slider reaches end. Then back to the center point and wait for 2 second until the "STATUS" LED flashes red. Repeat this to the right again to finish the travel limit setting.

When paired with a T-REX 500/600/700, please remember to set the STATUS LED to green. If you want to set delay at the same time, please move the transmitter rudder stick to the direction where STATUS LED is green. With the DELAY STATUS LED flashing, the delay amount is adjusted by stick position from the center: percentage is 0% at middle stick position, and 100% at the end position.

Specifications

Gyro :

Operating Voltage	DC 4.5~7V
Current Consumption	<80mA @ 4.8V
Angular Detection Speed	\pm 500 degrees/sec
Operating Temperature	-20 $^{\circ}$ C~65 $^{\circ}$ C
Operating Humidity	0%~95%
Size	26x25x11mm
Weight	14g

●RoHS compliant

DS620 Digital Servo :

Speed	0.09sec /60 degrees(4.8V)
	0.07sec /60 degrees(6.0V)
Torque	8kg.cm (4.8V)
	10kg.cm (6.0V)
Dimension	40.3 x 20.1 x 36mm
Weight	52.2g

Illustration

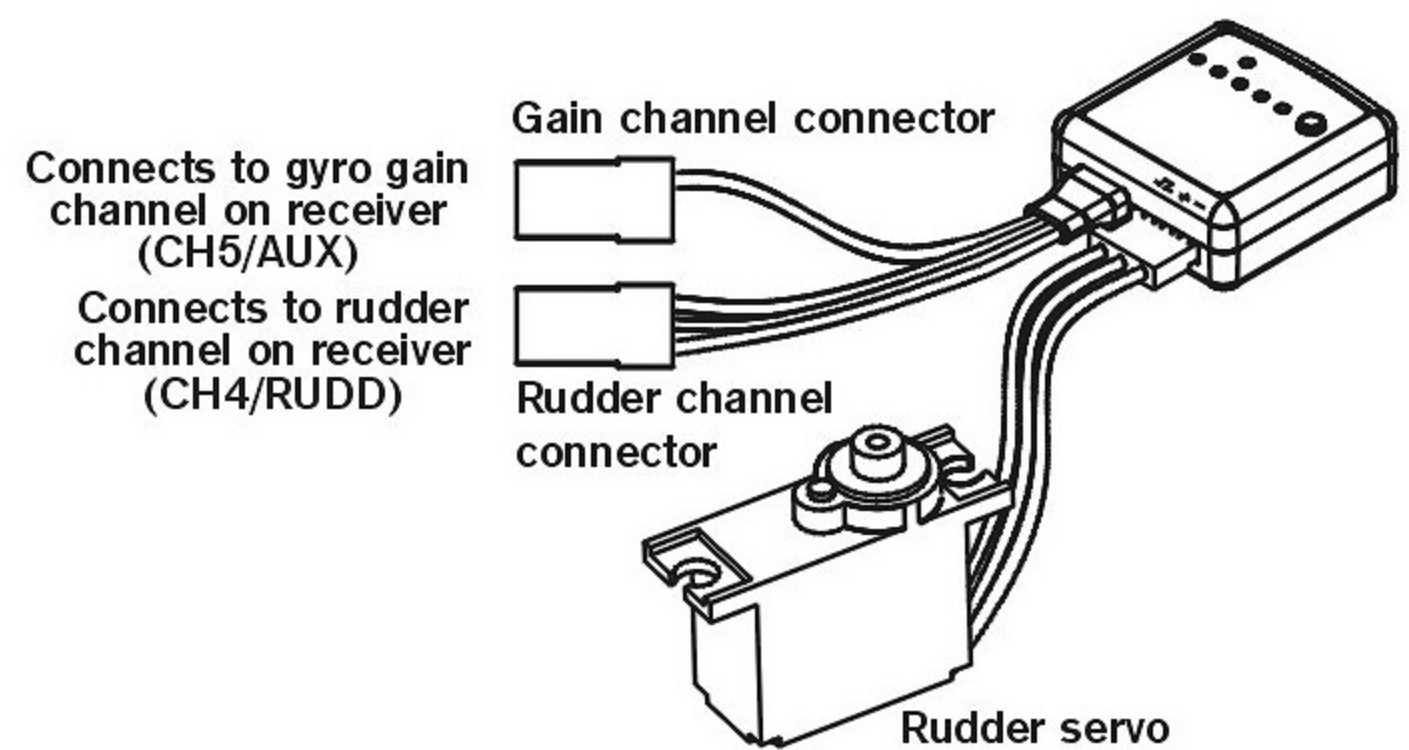
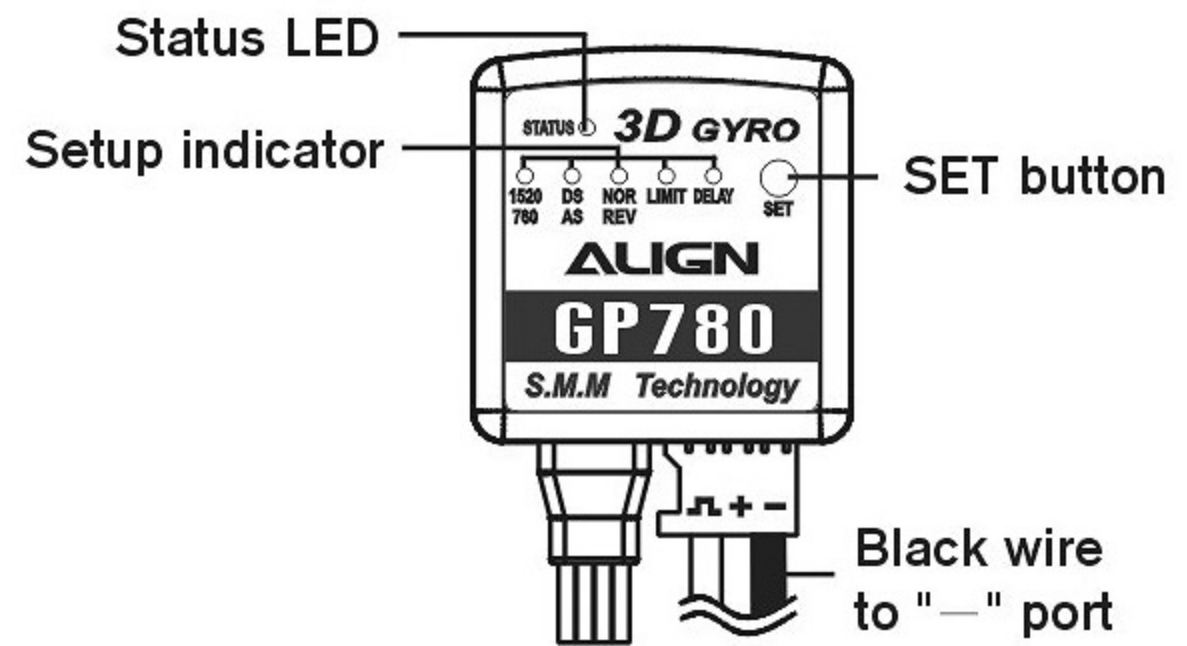

Gain And Rudder Channel Mapping Diagram

Transmitter type	Rudder channel on Receiver	Gain channel on Receiver
JR PPM/SPCM	"RUDD"	"AUX 2" or "AUX 3"
Hitec、Futaba PPM/PCM	"CH4"(RUD)	"CH5"
JR ZPCM	"RUDD"	"AUX 2"

Gyro Installation

1. Utilizing the included double sided foam tape as shown in diagram below, mount the gyro on a solid platform or designated gyro mounting location on the helicopter. Ensure gyro mounting area have proper ventilation and away from heat sources.
2. To avoid drift induced by erroneous yaw detection, the bottom surface of gyro must be perpendicular (90 degrees) relative to the main shaft.
3. For installation on electric powered helicopters, the gyro should be installed as far away from the electronic speed controller (ESC) as possible to avoid interference (minimum 5cm).

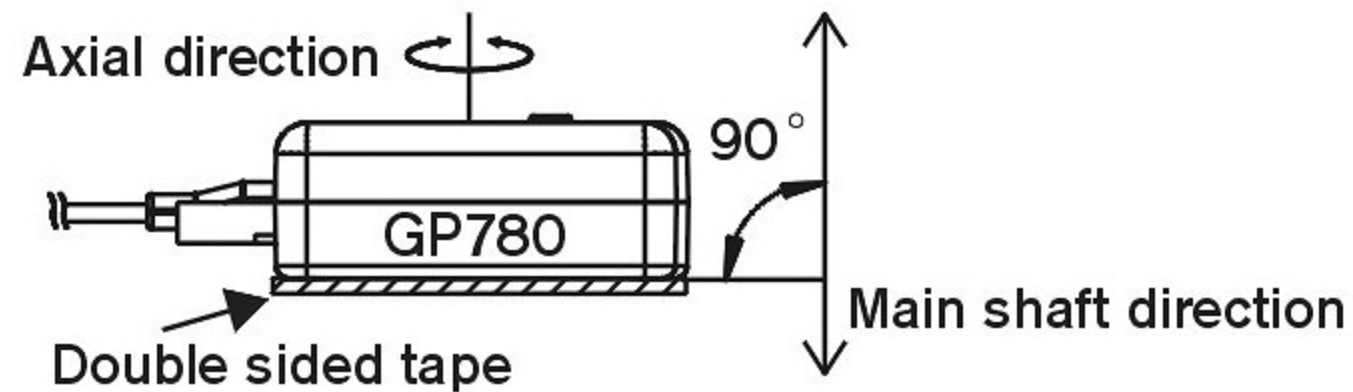

Usage Setting Instructions

1. **Transmitter Settings:** After powering up transmitter, make sure rudder subtrim is zeroed. Then power on the receiver and gyro. The gyro will go through initializing process indicated by flashing LED from left to right. Do not touch the heli or transmitter sticks until initializing is complete, as indicated by a steady lit LED. A green LED indicates gyro is in AHTCS locking mode, while red LED indicates gyro is in normal mode.

CAUTION The GP780 is set to 1520 μ s at the factory. If 760 μ s servo is used in 1520 μ s mode, rudder servo will deflect to the side and unable to center. For more critically, the linkage rod may jam and cause the servo burned out. Please follow the instruction (Usage setting 2) to change the setting if 760 μ s servo is used. Please ensure the following mixing functions (if available) are disabled or zeroed on the transmitter.

- ATS
- Pilot authority mixing
- Throttle to rudder mixing
- Rudder to gyro mixing
- Pitch to rudder mixing
- Revolution mixing

2. **1520 μ s (standard) or 760 μ s (narrow band) servo selection:** GP780 offers compatibility for two types of frame rates under digital mode. Please set the GP780 to 760 mode if 760 μ s frame rate rudder servos (such as Futaba S9256, S9251, BLS251) are used. Most other servos have 1520 μ s frame rate, and GP780 should be set to 1520 mode if those servos are used.

To enter the setup mode: Press and hold the SET button for 2 seconds, and the STATUS LED will begin flashing. When the 1520/760 indicator lit up, you are in the servo frame rate setup menu. Use the rudder stick on your transmitter to select the frame rate: move the stick to left (or right) and STATUS led changes to green, the frame rate has been set to 1520 μ s. If you want to set the frame rate to 760 μ s, move the stick to opposite end 3 times to make STATUS led changes to red.

CAUTION The faceplate of GP780 has the setting values listed in the corresponding green/red letters. Press the SET to confirm the current setting and enter the next setting. The GP780 will exit setting mode if left idle for 10 seconds.

3. **Digital (DS) / Analog (AS) Servo Selection:** Servo speed is of paramount importance in maximizing the gyro's performance. Fast servos are able to respond to gyro commands quickly, resulting in the speed and precision of overall system. Due to the high sensitivity of GP780 gyro, high speed digital servos such as Align DS650, DS620, DS520, DS420, Futaba S9257, S9256, S9254, S9253, or other similar spec servos are recommended. Select "DS" when digital servos are used, and "AS" when analog servos are used.

To enter the setup mode: Press and hold the SET button for 2 seconds, and the STATUS LED will begin flashing. Press the SET button repeatedly until DS/AS led is lit. Use the rudder stick on your transmitter to select the Servo type: move the stick to left (or right) and STATUS led changes to green, the servo type is set to DS. Move the stick to opposite direction and STATUS led changes to red, the servo type is set to AS.

WARNING The use of analog servo under "DS" mode will result in servo failure. The GP780 gyros are set to "DS" mode at the factory. Please set the proper servo type based on servo used.

4. Check the direction of rudder: Move the rudder stick on transmitter left/right and check the helicopter's instruction manual for correct rudder direction. Servo reverse function on the transmitter can be used for reversed rudder. Set the transmitter gyro gain channel to normal mode, or press and hold the SET button for 2 seconds to center the rudder servo. Adjust the servo horn so it is perpendicular (90 degrees) relative to the pushrod. Then adjust the rudder linkage length so the tail pitch control system is within range.

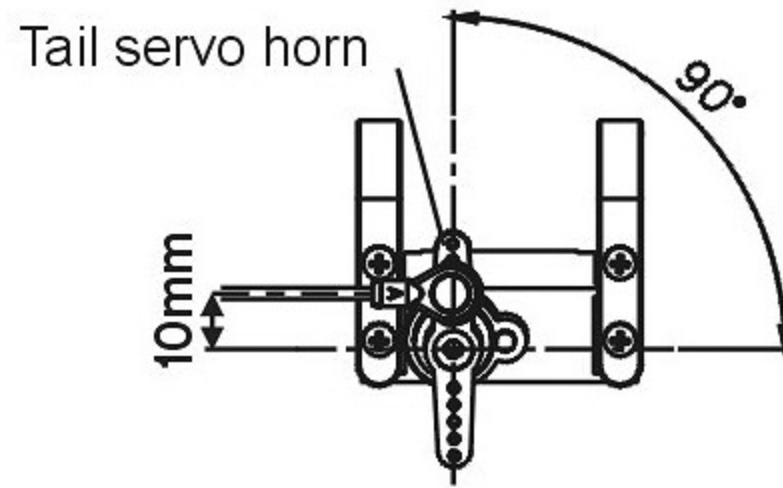

Utilizing DS620 rudder servo as an example, the recommended location of linkage connection is the second hole from the center on the servo horn. The ideal distance from linkage connection to servo center is 10mm.

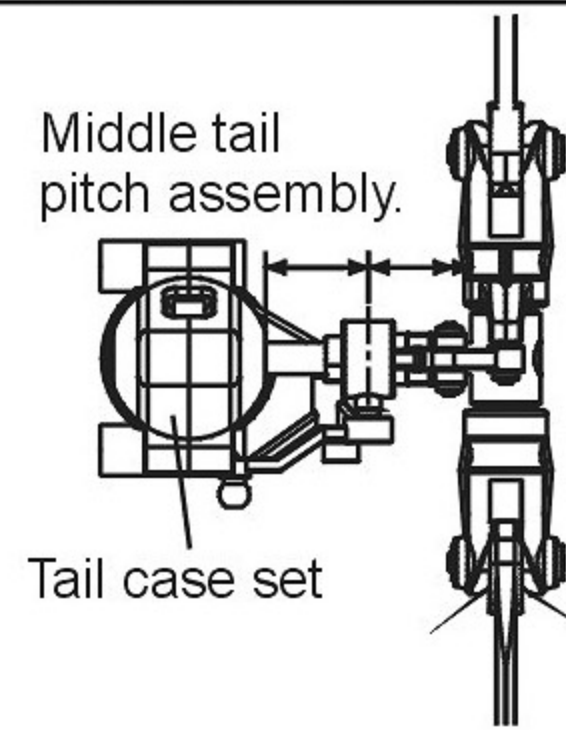

5. Setting of gyro direction nor/rev: Check the gyro direction by moving the heli on the yaw axis while holding by hand. Observe the direction gyro is moving the rudder servo. If direction is incorrect, switch the direction switch on the gyro to compensate.

To enter the setup mode: Press and hold the SET button for 2 seconds, and the STATUS LED will begin flashing. Press the SET button repeatedly until NOR/REV led is lit. Use the rudder stick on your transmitter to select the Servo type: move the stick to left (or right) and STATUS led changes to green, the servo direction is set to NOR. Move the stick to opposite direction and STATUS led changes to red, the servo direction is set to REV.



WARNING Flying with reversed gyro will cause the heli to spin out of control. Please double check the direction before attempting to fly the heli.

6. Rudder Servo Travel Limit Adjustment: Press and hold the SET button for 2 seconds until the STATUS LED flashes. At this point the rudder servo will be centered. Press the SET button repeatedly until LIMIT led is lit. While observing the heli tail, gradually move the rudder stick on your transmitter left until the tail pitch slider reaches its mechanical end (without binding), then center the rudder stick and wait 2 seconds until STATUS LED flashes red. Now perform the same for right rudder: move the rudder stick on your transmitter right until the tail pitch slider reaches the other end, center the stick and wait 2 seconds for LED to flash again. This will set the travel limit of the servo on both sides. Insufficient rudder servo travel limit will result in decreased rudder performance, while excessive rudder servo travel will overload the rudder servo and cause failures.



CAUTION Rudder travel setting can not be below 50%, or else GP780 will not register the settings. If excessive travel is observed even after performing the above rudder travel adjustments, please relocate the rudder servo linkage ball closer to the center of servo horn.

7. Gyro Gain Adjustments: For radio with GYRO function, gain can be adjusted using this function. The AHTCS (heading lock) gain is set by adjusting the GYRO setting between 50% to 100%, while the normal mode gain is set by adjusting the GYRO setting between 0 to 49%. Actual gain settings will differ amongst different helis and/or servo. The goal is to achieve as high of gain as possible without the tail oscillating (wagging), therefore such adjustment can only be done under actual flight conditions. Suggested initial settings are 70-80% during hover, and 60-70% during idle-up conditions. Gyro gain can be increased or decreased after observing the presence of tail oscillation during flights.



CAUTION For radio systems using 0-100% as gain adjustment under heading lock mode (such as Futaba), the recommended gain setting is approximately 30-35%. For radio system using 50-100% as gain adjustment under heading lock mode (such as JR and Hitec), the recommended gain setting is approximately 70-75%.

8. Helicopter mode and delay setting. These settings incorporates two functions:

- (1) GP780 supports mini/micro indoor helicopters. Set the setting based on the appropriate helicopter class. For example: Set the helicopter mode to mini/micro setting (Status LED turns red) for T-Rex 250/450; set the helicopter mode to medium/large setting (Status LED turns green) for T-Rex 500/600/700.
- (2) Slow rudder servos may cause tail oscillation as it receives the faster signal from gyro. If tail oscillation occurs after hard stop from stationary pirouette, increase the gain setting until such oscillation stops. Generally the delay value should be as low as possible, and used only to compensate for slower servos.

Setting Method: Press and hold the SET button for 2 seconds to enter the setup menu, and select DELAY setting. Push the rudder stick left or right and observe the STATUS LED. RED STATUS represents mini/micro helis such as T-REX250/450, GREEN STATUS represents medium/large helis such as T-REX500/600/700. The amount of delay is set by holding the rudder stick at the position corresponding the delay percentage, 0% at middle stick position (DELAY STATUS LED is flashing) and 100% at the end position, and pressing the SET button to confirm the delay setting.